



Pro Deep Learning with TensorFlow

A Mathematical Approach to Advanced Artificial Intelligence in Python

—

Santanu Pattanayak

Apress®

Pro Deep Learning with TensorFlow

A Mathematical Approach to Advanced Artificial Intelligence in Python



Santanu Pattanayak

Apress®

Pro Deep Learning with TensorFlow

Santanu Pattanayak
Bangalore, Karnataka, India

ISBN-13 (pbk): 978-1-4842-3095-4
<https://doi.org/10.1007/978-1-4842-3096-1>

ISBN-13 (electronic): 978-1-4842-3096-1

Library of Congress Control Number: 2017962327

Copyright © 2017 by Santanu Pattanayak

This work is subject to copyright. All rights are reserved by the Publisher, whether the whole or part of the material is concerned, specifically the rights of translation, reprinting, reuse of illustrations, recitation, broadcasting, reproduction on microfilms or in any other physical way, and transmission or information storage and retrieval, electronic adaptation, computer software, or by similar or dissimilar methodology now known or hereafter developed.

Trademarked names, logos, and images may appear in this book. Rather than use a trademark symbol with every occurrence of a trademarked name, logo, or image we use the names, logos, and images only in an editorial fashion and to the benefit of the trademark owner, with no intention of infringement of the trademark.

The use in this publication of trade names, trademarks, service marks, and similar terms, even if they are not identified as such, is not to be taken as an expression of opinion as to whether or not they are subject to proprietary rights.

While the advice and information in this book are believed to be true and accurate at the date of publication, neither the authors nor the editors nor the publisher can accept any legal responsibility for any errors or omissions that may be made. The publisher makes no warranty, express or implied, with respect to the material contained herein.

Cover image by Freepik (www.freepik.com)

Managing Director: Welmoed Spahr
Editorial Director: Todd Green
Acquisitions Editor: Celestin Suresh John
Development Editor: Laura Berendson
Technical Reviewer: Manohar Swamynathan
Coordinating Editor: Sanchita Mandal
Copy Editor: April Rondeau

Distributed to the book trade worldwide by Springer Science+Business Media New York, 233 Spring Street, 6th Floor, New York, NY 10013. Phone 1-800-SPRINGER, fax (201) 348-4505, email orders-ny@springer-sbm.com, or visit www.springeronline.com. Apress Media, LLC is a California LLC and the sole member (owner) is Springer Science + Business Media Finance Inc (SSBM Finance Inc). SSBM Finance Inc is a **Delaware** corporation.

For information on translations, please email rights@apress.com, or visit <http://www.apress.com/rights-permissions>.

Apress titles may be purchased in bulk for academic, corporate, or promotional use. eBook versions and licenses are also available for most titles. For more information, reference our Print and eBook Bulk Sales web page at <http://www.apress.com/bulk-sales>.

Any source code or other supplementary material referenced by the author in this book is available to readers on GitHub via the book's product page, located at www.apress.com/978-1-4842-3095-4. For more detailed information, please visit <http://www.apress.com/source-code>.

Printed on acid-free paper

To my wife, Sonia.

Contents

About the Author	xiii
About the Technical Reviewer	xv
Acknowledgments	xvii
Introduction	xix
■ Chapter 1: Mathematical Foundations	1
Linear Algebra	2
Vector	3
Scalar	4
Matrix	4
Tensor	5
Matrix Operations and Manipulations.....	5
Linear Independence of Vectors	9
Rank of a Matrix	10
Identity Matrix or Operator	11
Determinant of a Matrix.....	12
Inverse of a Matrix.....	14
Norm of a Vector.....	15
Pseudo Inverse of a Matrix.....	16
Unit Vector in the Direction of a Specific Vector	17
Projection of a Vector in the Direction of Another Vector.....	17
Eigen Vectors	18
Calculus	23
Differentiation.....	23
Gradient of a Function	24

Successive Partial Derivatives.....	25
Hessian Matrix of a Function	25
Maxima and Minima of Functions	26
Local Minima and Global Minima	28
Positive Semi-Definite and Positive Definite	29
Convex Set.....	29
Convex Function	30
Non-convex Function.....	31
Multivariate Convex and Non-convex Functions Examples	31
Taylor Series	34
Probability	34
Unions, Intersection, and Conditional Probability	35
Chain Rule of Probability for Intersection of Event	37
Mutually Exclusive Events	37
Independence of Events	37
Conditional Independence of Events	38
Bayes Rule.....	38
Probability Mass Function	38
Probability Density Function.....	39
Expectation of a Random Variable	39
Variance of a Random Variable.....	39
Skewness and Kurtosis	40
Covariance.....	44
Correlation Coefficient.....	44
Some Common Probability Distribution.....	45
Likelihood Function	51
Maximum Likelihood Estimate	52
Hypothesis Testing and p Value	53
Formulation of Machine-Learning Algorithm and Optimization Techniques.....	55
Supervised Learning.....	56
Unsupervised Learning.....	65

Optimization Techniques for Machine Learning.....	66
Constrained Optimization Problem	77
A Few Important Topics in Machine Learning	79
Dimensionality Reduction Methods	79
Regularization.....	84
Regularization Viewed as a Constraint Optimization Problem	86
Summary.....	87
■ Chapter 2: Introduction to Deep-Learning Concepts and TensorFlow	89
Deep Learning and Its Evolution.....	89
Perceptrons and Perceptron Learning Algorithm	92
Geometrical Interpretation of Perceptron Learning	96
Limitations of Perceptron Learning	97
Need for Non-linearity	99
Hidden Layer Perceptrons' Activation Function for Non-linearity	100
Different Activation Functions for a Neuron/Perceptron.....	102
Learning Rule for Multi-Layer Perceptrons Network.....	108
Backpropagation for Gradient Computation	109
Generalizing the Backpropagation Method for Gradient Computation	111
TensorFlow	118
Common Deep-Learning Packages	118
TensorFlow Installation.....	119
TensorFlow Basics for Development	119
Gradient-Descent Optimization Methods from a Deep-Learning Perspective	123
Learning Rate in Mini-batch Approach to Stochastic Gradient Descent.....	129
Optimizers in TensorFlow	130
XOR Implementation Using TensorFlow	138
Linear Regression in TensorFlow.....	143
Multi-class Classification with SoftMax Function Using Full-Batch Gradient Descent.....	146
Multi-class Classification with SoftMax Function Using Stochastic Gradient Descent	149
GPU.....	152
Summary.....	152

■ **Chapter 3: Convolutional Neural Networks** 153

Convolution Operation 153

 Linear Time Invariant (LTI) / Linear Shift Invariant (LSI) Systems 153

 Convolution for Signals in One Dimension..... 155

Analog and Digital Signals 158

 2D and 3D signals..... 160

2D Convolution 161

 Two-dimensional Unit Step Function..... 161

 2D Convolution of a Signal with an LSI System Unit Step Response..... 163

 2D Convolution of an Image to Different LSI System Responses 165

Common Image-Processing Filters 169

 Mean Filter 169

 Median Filter..... 171

 Gaussian Filter..... 173

 Gradient-based Filters 174

 Sobel Edge-Detection Filter..... 175

 Identity Transform..... 177

Convolution Neural Networks..... 178

Components of Convolution Neural Networks..... 179

 Input Layer..... 180

 Convolution Layer 180

 Pooling Layer 182

Backpropagation Through the Convolutional Layer..... 182

Backpropagation Through the Pooling Layers..... 186

Weight Sharing Through Convolution and Its Advantages..... 187

Translation Equivariance 188

Translation Invariance Due to Pooling 189

Dropout Layers and Regularization 190

Convolutional Neural Network for Digit Recognition on the MNIST Dataset 192

Convolutional Neural Network for Solving Real-World Problems	196
Batch Normalization	204
Different Architectures in Convolutional Neural Networks	206
LeNet	206
AlexNet	208
VGG16	209
ResNet	210
Transfer Learning	211
Guidelines for Using Transfer Learning.....	212
Transfer Learning with Google’s InceptionV3	213
Transfer Learning with Pre-trained VGG16	216
Summary.....	221
■ Chapter 4: Natural Language Processing Using Recurrent Neural Networks....	223
Vector Space Model (VSM)	223
Vector Representation of Words	227
Word2Vec	228
Continuous Bag of Words (CBOW).....	228
Continuous Bag of Words Implementation in TensorFlow.....	231
Skip-Gram Model for Word Embedding	235
Skip-gram Implementation in TensorFlow	237
Global Co-occurrence Statistics–based Word Vectors.....	240
GloVe.....	245
Word Analogy with Word Vectors	249
Introduction to Recurrent Neural Networks.....	252
Language Modeling	254
Predicting the Next Word in a Sentence Through RNN Versus Traditional Methods	255
Backpropagation Through Time (BPTT)	256
Vanishing and Exploding Gradient Problem in RNN.....	259
Solution to Vanishing and Exploding Gradients Problem in RNNs	260
Long Short-Term Memory (LSTM)	262

LSTM in Reducing Exploding- and Vanishing -Gradient Problems	263
MNIST Digit Identification in TensorFlow Using Recurrent Neural Networks.....	265
Gated Recurrent Unit (GRU)	274
Bidirectional RNN	276
Summary.....	278
■ Chapter 5: Unsupervised Learning with Restricted Boltzmann Machines and Auto-encoders	279
Boltzmann Distribution.....	279
Bayesian Inference: Likelihood, Priors, and Posterior Probability Distribution.....	281
Markov Chain Monte Carlo Methods for Sampling.....	286
Metropolis Algorithm	289
Restricted Boltzmann Machines.....	294
Training a Restricted Boltzmann Machine	299
Gibbs Sampling.....	304
Block Gibbs Sampling.....	305
Burn-in Period and Generating Samples in Gibbs Sampling	306
Using Gibbs Sampling in Restricted Boltzmann Machines	306
Contrastive Divergence.....	308
A Restricted Boltzmann Implementation in TensorFlow	309
Collaborative Filtering Using Restricted Boltzmann Machines	313
Deep Belief Networks (DBNs)	317
Auto-encoders.....	322
Feature Learning Through Auto-encoders for Supervised Learning.....	325
Kullback-Leibler (KL) Divergence	327
Sparse Auto-Encoder Implementation in TensorFlow.....	329
Denoising Auto-Encoder	333
A Denoising Auto-Encoder Implementation in TensorFlow	333
PCA and ZCA Whitening.....	340
Summary.....	343

■ **Chapter 6: Advanced Neural Networks**..... **345**

Image Segmentation **345**

 Binary Thresholding Method Based on Histogram of Pixel Intensities 345

 Otsu's Method..... 346

 Watershed Algorithm for Image Segmentation..... 349

 Image Segmentation Using K-means Clustering 352

 Semantic Segmentation 355

 Sliding-Window Approach 355

 Fully Convolutional Network (FCN) 356

 Fully Convolutional Network with Downsampling and Upsampling 358

 U-Net 364

 Semantic Segmentation in TensorFlow with Fully Connected Neural Networks 365

Image Classification and Localization Network..... **373**

Object Detection **375**

 R-CNN 376

 Fast and Faster R-CNN 377

Generative Adversarial Networks **378**

 Maximin and Minimax Problem 379

 Zero-sum Game 381

 Minimax and Saddle Points 382

 GAN Cost Function and Training 383

 Vanishing Gradient for the Generator 386

 TensorFlow Implementation of a GAN Network 386

TensorFlow Models' Deployment in Production **389**

Summary..... **392**

Index..... **393**

About the Author



Santanu Pattanayak currently works at GE, Digital as a senior data scientist. He has ten years of overall work experience, with six of years of experience in the data analytics/data science field. He also has a background in development and database technologies. Prior to joining GE, Santanu worked at companies such as RBS, Capgemini, and IBM. He graduated with a degree in electrical engineering from Jadavpur University, Kolkata in India and is an avid math enthusiast. Santanu is currently pursuing a master's degree in data science from Indian Institute of Technology (IIT), Hyderabad. He also devotes his time to data science hackathons and Kaggle competitions, where he ranks within the top five hundred across the globe. Santanu was born and raised in West Bengal, India, and currently resides in Bangalore, India, with his wife. You can visit him at <http://www.santanupattanayak.com/> to check out his current activities.

About the Technical Reviewer



Manohar Swamynathan is a data science practitioner and an avid programmer, with over thirteen years of experience in various data science-related areas, including data warehousing, business intelligence (BI), analytical tool development, ad-hoc analysis, predictive modeling, data science product development, consulting, formulating strategy, and executing analytics programs. His career has covered the life cycle of data across different domains, such as US mortgage banking, retail/e-commerce, insurance, and industrial Internet of Things (IoT). He has a bachelor's degree with a specialization in physics, mathematics, and computers, as well as a master's degree in project management. He's currently living in Bengaluru, the Silicon Valley of India.

He authored the book *Mastering Machine Learning with Python in Six Steps*. You can learn more about his various other activities at <http://www.mswamynathan.com>.

Acknowledgments

I am grateful to my wife, Sonia, for encouraging me at every step while writing this book. I would like to thank my mom for her unconditional love and my dad for instilling in me a love for mathematics. I would also like to thank my brother, Atanu, and my friend Partha for their constant support.

Thanks to Manohar for his technical input and constant guidance. I would like to express my gratitude to my mentors, colleagues, and friends from current and previous organizations for their input, inspiration, and support. Sincere thanks to the Apress team for their constant support and help.

Introduction

Pro Deep Learning with TensorFlow is a practical and mathematical guide to deep learning using TensorFlow. Deep learning is a branch of machine learning where you model the world in terms of a hierarchy of concepts. This pattern of learning is similar to the way a human brain learns, and it allows computers to model complex concepts that often go unnoticed in other traditional methods of modeling. Hence, in the modern computing paradigm, deep learning plays a vital role in modeling complex real-world problems, especially by leveraging the massive amount of unstructured data available today.

Because of the complexities involved in a deep-learning model, many times it is treated as a black box by people using it. However, to derive the maximum benefit from this branch of machine learning, one needs to uncover the hidden mystery by looking at the science and mathematics associated with it. In this book, great care has been taken to explain the concepts and techniques associated with deep learning from a mathematical as well as a scientific viewpoint. Also, the first chapter is totally dedicated toward building the mathematical base required to comprehend deep-learning concepts with ease. TensorFlow has been chosen as the deep-learning package because of its flexibility for research purposes and its ease of use. Another reason for choosing TensorFlow is its capability to load models with ease in a live production environment using its serving capabilities.

In summary, *Pro Deep Learning with TensorFlow* provides practical, hands-on expertise so you can learn deep learning from scratch and deploy meaningful deep-learning solutions. This book will allow you to get up to speed quickly using TensorFlow and to optimize different deep-learning architectures. All the practical aspects of deep learning that are relevant in any industry are emphasized in this book. You will be able to use the prototypes demonstrated to build new deep-learning applications. The code presented in the book is available in the form of iPython notebooks and scripts that allow you to try out examples and extend them in interesting ways. You will be equipped with the mathematical foundation and scientific knowledge to pursue research in this field and give back to the community.

Who This Book Is For

- This book is for data scientists and machine-learning professionals looking at deep-learning solutions to solve complex business problems.
- This book is for software developers working on deep-learning solutions through TensorFlow.
- This book is for graduate students and open source enthusiasts with a constant desire to learn.

What You'll Learn

The chapters covered in this book are as follows:

Chapter 1 — *Mathematical Foundations*: In this chapter, all the relevant mathematical concepts from linear algebra, probability, calculus, optimization, and machine-learning formulation are discussed in detail to lay the mathematical foundation required for deep learning. The various concepts are explained with a focus on their use in the fields of machine learning and deep learning.

Chapter 2 — *Introduction to Deep-Learning Concepts and TensorFlow*: This chapter introduces the world of deep learning and discusses its evolution over the years. The key building blocks of neural networks, along with several methods of learning, such as the perceptron-learning rule and backpropagation methods, are discussed in detail. Also, this chapter introduces the paradigm of TensorFlow coding so that readers are accustomed to the basic syntax before moving on to more-involved implementations in TensorFlow.

Chapter 3 — *Convolutional Neural Networks*: This chapter deals with convolutional neural networks used for image processing. Image processing is a computer vision issue that has seen a huge boost in performance in the areas of object recognition and detection, object classification, localization, and segmentation using convolutional neural networks. The chapter starts by illustrating the operation of convolution in detail and then moves on to the working principles of a convolutional neural network. Much emphasis is given to the building blocks of a convolutional neural network to give the reader the tools needed to experiment and extend their networks in interesting ways. Further, backpropagation through convolutional and pooling layers is discussed in detail so that the reader has a holistic view of the training process of convolutional networks. Also covered in this chapter are the properties of equivariance and translation invariance, which are central to the success of convolutional neural networks.

Chapter 4 — *Natural Language Processing Using Recurrent Neural Networks*: This chapter deals with natural language processing using deep learning. It starts with different vector space models for text processing; word-to-vector embedding models, such as the continuous bag of words method and skip-grams; and then moves to much more advanced topics that involve recurrent neural networks (RNN), LSTM, bidirectional RNN, and GRU. Language modeling is covered in detail in this chapter to help the reader utilize these networks in real-world problems involving the same. Also, the mechanism of backpropagation in cases of RNNs and LSTM as well as vanishing-gradient problems are discussed in much detail.

Chapter 5 — *Unsupervised Learning with Restricted Boltzmann Machines and Auto-encoders*: In this chapter, you will learn about unsupervised methods in deep learning that use restricted Boltzmann machines (RBMs) and auto-encoders. Also, the chapter will touch upon Bayesian inference and Markov chain Monte Carlo (MCMC) methods, such as the Metropolis algorithm and Gibbs sampling, since the RBM training process requires some knowledge of sampling. Further, this chapter will discuss contrastive divergence, a customized version of Gibbs sampling that allows for the practical training of RBMs. We will further discuss how RBMs can be used for collaborative filtering in recommender systems as well as their use in unsupervised pre-training of deep belief networks (DBNs).

In the second part of the chapter, various kinds of auto-encoders are covered, such as sparse encoders, denoising auto-encoders, and so forth. Also, the reader will learn about how internal features learned from the auto-encoders can be utilized for dimensionality reduction as well as for supervised learning. Finally, the chapter ends with a little brief on data pre-processing techniques, such as PCA whitening and ZCA whitening.

Chapter 6 — *Advanced Neural Networks*: In this chapter, the reader will learn about some of the advanced neural networks, such as fully convolutional neural networks, R-CNN, Fast R-CNN, Faster, U-Net, and so forth, that deal with semantic segmentation of images, object detection, and localization. This chapter also introduces the readers to traditional image segmentation methods so that they can combine the best of both worlds as appropriate. In the second half of the chapter, the reader will learn about the Generative Adversarial Network (GAN), a new schema of generative model used for producing synthetic data like the data produced by a given distribution. GAN has usages and potential in several fields, such as in image generation, image inpainting, abstract reasoning, semantic segmentation, video generation, style transfer from one domain to another, and text-to-image generation applications, among others.

To summarize, the key learnings the reader can expect from this book are as follows:

- Understand full-stack deep learning using TensorFlow and gain a solid mathematical foundation for deep learning
- Deploy complex deep-learning solutions in production using TensorFlow
- Carry out research on deep learning and perform experiments using TensorFlow

CHAPTER 1



Mathematical Foundations

Deep learning is a branch of machine learning that uses many layers of artificial neurons stacked one on top of the other for identifying complex features within the input data and solving complex real-world problems. It can be used for both supervised and unsupervised machine-learning tasks. Deep learning is currently used in areas such as computer vision, video analytics, pattern recognition, anomaly detection, text processing, sentiment analysis, and recommender system, among other things. Also, it has widespread use in robotics, self-driving car mechanisms, and in artificial intelligence systems in general.

Mathematics is at the heart of any machine-learning algorithm. A strong grasp of the core concepts of mathematics goes a long way in enabling one to select the right algorithms for a specific machine-learning problem, keeping in mind the end objectives. Also, it enables one to tune machine-learning/deep-learning models better and understand what might be the possible reasons for an algorithm's not performing as desired. Deep learning being a branch of machine learning demands as much expertise in mathematics, if not more, than that required for other machine-learning tasks. Mathematics as a subject is vast, but there are a few specific topics that machine-learning or deep-learning professionals and/or enthusiasts should be aware of to extract the most out of this wonderful domain of machine learning, deep learning, and artificial intelligence. Illustrated in Figure 1-1 are the different branches of mathematics along with their importance in the field of machine learning and deep learning. We will discuss the relevant concepts in each of the following branches in this chapter:

- Linear algebra
- Probability and statistics
- Calculus
- Optimization and formulation of machine-learning algorithms

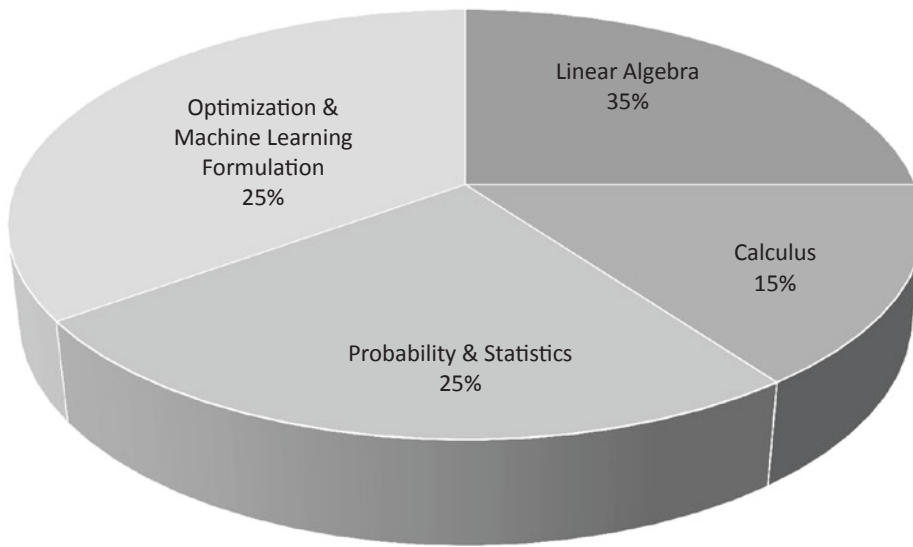

Figure 1-1. Importance of mathematics topics for machine learning and data science

■ **Note** Readers who are already familiar with these topics can choose to skip this chapter or have a casual glance through the content.

Linear Algebra

Linear algebra is a branch of mathematics that deals with vectors and their transformation from one vector space to another vector space. Since in machine learning and deep learning we deal with multidimensional data and their manipulation, linear algebra plays a crucial role in almost every machine-learning and deep-learning algorithm. Illustrated in Figure 1-2 is a three-dimensional vector space where v_1, v_2 and v_3 are vectors and P is a 2-D plane within the three-dimensional vector space.

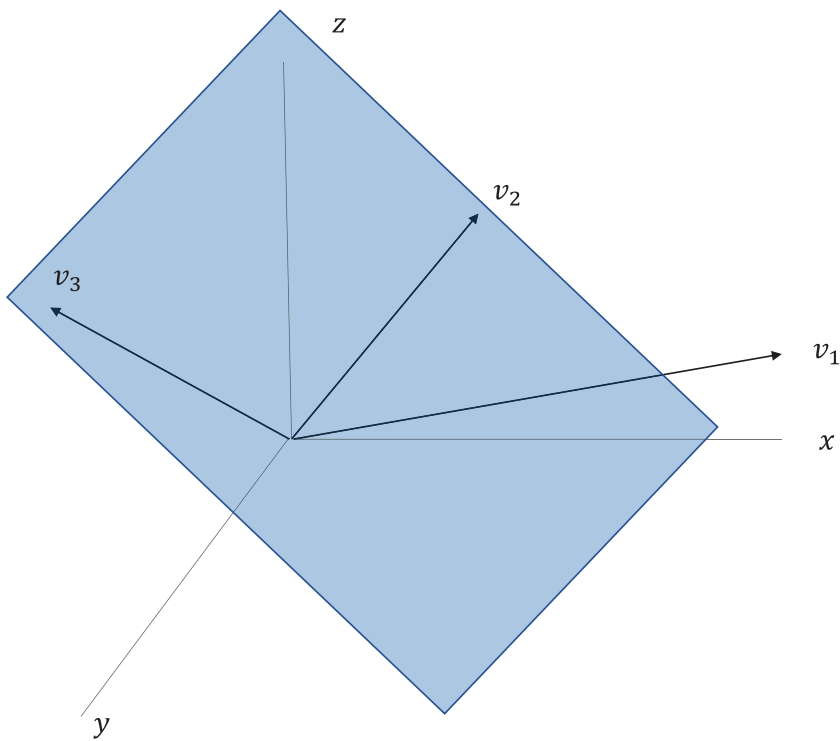

Figure 1-2. Three-dimensional vector space with vectors and a vector plane

Vector

An array of numbers, either continuous or discrete, is called a vector, and the space consisting of vectors is called a vector space. Vector space dimensions can be finite or infinite, but most machine-learning or data-science problems deal with fixed-length vectors; for example, the velocity of a car moving in the plane with velocities V_x and V_y in the x and y direction respectively (see Figure 1-3).

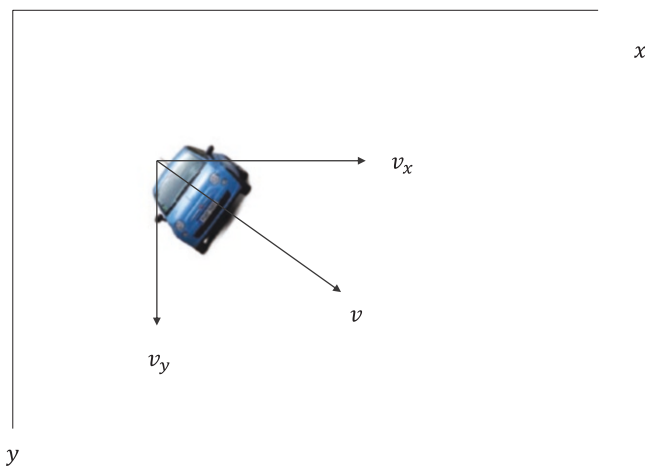

Figure 1-3. Car moving in the x - y vector plane with velocity components V_x and V_y

In machine learning, we deal with multidimensional data, so vectors become very crucial. Let's say we are trying to predict the housing prices in a region based on the area of the house, number of bedrooms, number of bathrooms, and population density of the locality. All these features form an input-feature vector for the housing price prediction problem.

Scalar

A one-dimensional vector is a scalar. As learned in high school, a scalar is a quantity that has only magnitude and no direction. This is because, since it has only one direction along which it can move, its direction is immaterial, and we are only concerned about the magnitude.

Examples: height of a child, weight of fruit, etc.

Matrix

A matrix is a two-dimensional array of numbers arranged in rows and columns. The size of the matrix is determined by its row length and column length. If a matrix A has m rows and n columns, it can be represented as a rectangular object (see Figure 1-4a) having $m \times n$ elements, and it can be denoted as $A_{m \times n}$.

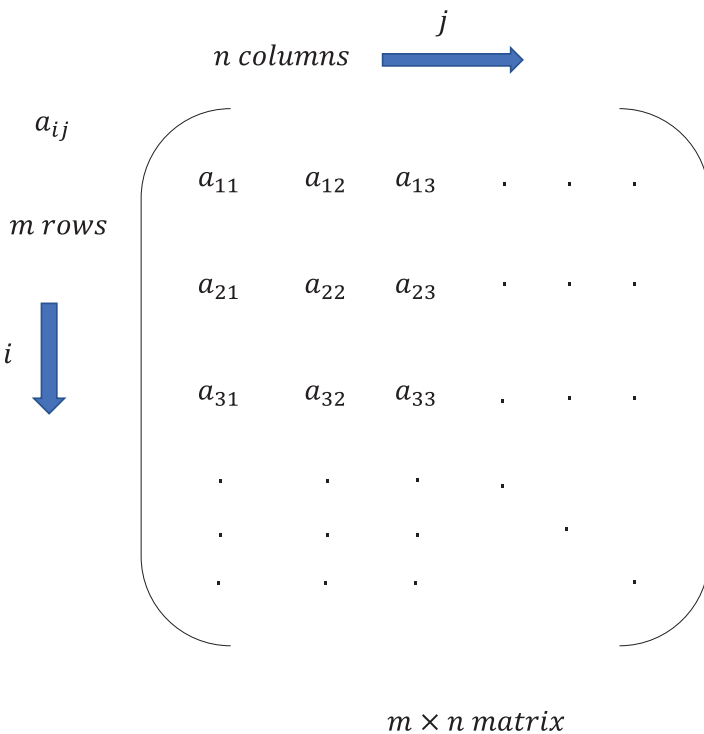

Figure 1-4a. Structure of a matrix

A few vectors belonging to the same vector space form a matrix.

For example, an image in grayscale is stored in a matrix form. The size of the image determines the image matrix size, and each matrix cell holds a value from 0–255 representing the pixel intensity. Illustrated in Figure 1-4b is a grayscale image followed by its matrix representation.



```
[255,254,255, ..., 255,255,254]
[255,254,255, ..., 255,255,254]
[255,254,255, ..., 255,255,254]
...
[255,254,255, ..., 255,255,254]
[255,254,255, ..., 255,255,254]
[255,254,255, ..., 255,255,254]
```

Internal Representation in Matrix form

Image

Figure 1-4b. Structure of a matrix

Tensor

A tensor is a multidimensional array of numbers. In fact, vectors and matrices can be treated as 1-D and 2-D tensors. In deep learning, tensors are mostly used for storing and processing data. For example, an image in RGB is stored in a three-dimensional tensor, where along one dimension we have the horizontal axis and along the other dimension we have the vertical axis, and where the third dimension corresponds to the three color channels, namely Red, Green, and Blue. Another example is the four-dimensional tensors used in feeding images through mini-batches in a convolutional neural network. Along the first dimension we have the image number in the batch and along the second dimension we have the color channels, and the third and fourth dimensions correspond to pixel location in the horizontal and vertical directions.

Matrix Operations and Manipulations

Most deep-learning computational activities are done through basic matrix operations, such as multiplication, addition, subtraction, transposition, and so forth. Hence, it makes sense to review the basic matrix operations.

A matrix A of m rows and n columns can be considered a matrix that contains n number of column vectors of dimension m stacked side-by-side. We represent the matrix as

$$A_{m \times n} \in \mathbb{R}^{m \times n}$$

Addition of Two Matrices

The addition of two matrices A and B implies their element-wise addition. We can only add two matrices, provided their dimensions match. If C is the sum of matrices A and B , then

$$c_{ij} = a_{ij} + b_{ij} \quad \forall i \in \{1, 2, \dots, m\}, \forall j \in \{1, 2, \dots, n\}$$

$$\text{where } a_{ij} \in A, b_{ij} \in B, c_{ij} \in C$$

$$\text{Example: } A = \begin{bmatrix} 1 & 2 \\ 3 & 4 \end{bmatrix} B = \begin{bmatrix} 5 & 6 \\ 7 & 8 \end{bmatrix} \text{ then } A + B = \begin{bmatrix} 1+5 & 2+6 \\ 3+7 & 4+8 \end{bmatrix} = \begin{bmatrix} 6 & 8 \\ 10 & 12 \end{bmatrix}$$

Subtraction of Two Matrices

The subtraction of two matrices A and B implies their element-wise subtraction. We can only subtract two matrices provided their dimensions match.

If C is the matrix representing $A - B$, then

$$c_{ij} = a_{ij} - b_{ij} \quad \forall i \in \{1, 2, \dots, m\}, \forall j \in \{1, 2, \dots, n\}$$

$$\text{where } a_{ij} \in A, b_{ij} \in B, c_{ij} \in C$$

$$\text{Example: } A = \begin{bmatrix} 1 & 2 \\ 3 & 4 \end{bmatrix} B = \begin{bmatrix} 5 & 6 \\ 7 & 8 \end{bmatrix} \text{ then } A - B = \begin{bmatrix} 1-5 & 2-6 \\ 3-7 & 4-8 \end{bmatrix} = \begin{bmatrix} -4 & -4 \\ -4 & -4 \end{bmatrix}$$

Product of Two Matrices

For two matrices $A \in \mathbb{R}^{m \times n}$ and $B \in \mathbb{R}^{n \times q}$ to be multipliable, n should be equal to p . The resulting matrix is $C \in \mathbb{R}^{m \times q}$. The elements of C can be expressed as

$$c_{ij} = \sum_{k=1}^n a_{ik} b_{kj} \quad \forall i \in \{1, 2, \dots, m\}, \forall j \in \{1, 2, \dots, q\}$$

For example, the matrix multiplication of the two matrices $A, B \in \mathbb{R}^{2 \times 2}$ can be computed as seen here:

$$A = \begin{bmatrix} 1 & 2 \\ 3 & 4 \end{bmatrix} B = \begin{bmatrix} 5 & 6 \\ 7 & 8 \end{bmatrix}$$

$$c_{11} = [1 \ 2] \begin{bmatrix} 5 \\ 7 \end{bmatrix} = 1 \times 5 + 2 \times 7 = 19 \quad c_{12} = [1 \ 2] \begin{bmatrix} 6 \\ 8 \end{bmatrix} = 1 \times 6 + 2 \times 8 = 22$$

$$c_{21} = [3 \ 4] \begin{bmatrix} 5 \\ 7 \end{bmatrix} = 3 \times 5 + 4 \times 7 = 43 \quad c_{22} = [3 \ 4] \begin{bmatrix} 6 \\ 8 \end{bmatrix} = 3 \times 6 + 4 \times 8 = 50$$

$$C = \begin{bmatrix} c_{11} & c_{12} \\ c_{21} & c_{22} \end{bmatrix} = \begin{bmatrix} 19 & 22 \\ 43 & 50 \end{bmatrix}$$

Transpose of a Matrix

The transpose of a matrix $A \in \mathbb{R}^{m \times n}$ is generally represented by $A^T \in \mathbb{R}^{n \times m}$ and is obtained by transposing the column vectors as row vectors.

$$a'_{ji} = a_{ij} \quad \forall i \in \{1, 2, \dots, m\}, \forall j \in \{1, 2, \dots, n\}$$

where $a'_{ji} \in A^T$ and $a_{ij} \in A$

Example: $A = \begin{bmatrix} 1 & 2 \\ 3 & 4 \end{bmatrix}$ then $A^T = \begin{bmatrix} 1 & 3 \\ 2 & 4 \end{bmatrix}$

The transpose of the product of two matrices A and B is the product of the transposes of matrices A and B in the reverse order; i.e., $(AB)^T = B^T A^T$

For example, if we take two matrices $A = \begin{bmatrix} 19 & 22 \\ 43 & 50 \end{bmatrix}$ and $B = \begin{bmatrix} 5 & 6 \\ 7 & 8 \end{bmatrix}$, then

$$(AB) = \begin{bmatrix} 19 & 22 \\ 43 & 50 \end{bmatrix} \begin{bmatrix} 5 & 6 \\ 7 & 8 \end{bmatrix} = \begin{bmatrix} 95 & 132 \\ 301 & 400 \end{bmatrix} \text{ and hence } (AB)^T = \begin{bmatrix} 95 & 301 \\ 132 & 400 \end{bmatrix}$$

Now, $A^T = \begin{bmatrix} 19 & 43 \\ 22 & 50 \end{bmatrix}$ and $B^T = \begin{bmatrix} 5 & 7 \\ 6 & 8 \end{bmatrix}$

$$B^T A^T = \begin{bmatrix} 5 & 7 \\ 6 & 8 \end{bmatrix} \begin{bmatrix} 19 & 43 \\ 22 & 50 \end{bmatrix} = \begin{bmatrix} 95 & 301 \\ 132 & 400 \end{bmatrix}$$

Hence, the equality $(AB)^T = B^T A^T$ holds.

Dot Product of Two Vectors

Any vector of dimension n can be represented as a matrix $v \in \mathbb{R}^{n \times 1}$. Let us denote two n dimensional vectors $v_1 \in \mathbb{R}^{n \times 1}$ and $v_2 \in \mathbb{R}^{n \times 1}$.

$$v_1 = \begin{bmatrix} v_{11} \\ v_{12} \\ \cdot \\ \cdot \\ v_{1n} \end{bmatrix} \quad v_2 = \begin{bmatrix} v_{21} \\ v_{22} \\ \cdot \\ \cdot \\ v_{2n} \end{bmatrix}$$

The dot product of two vectors is the sum of the product of corresponding components—i.e., components along the same dimension—and can be expressed as

$$v_1 \cdot v_2 = v_1^T v_2 = v_2^T v_1 = v_{11}v_{21} + v_{12}v_{22} + \dots + v_{1n}v_{2n} = \sum_{k=1}^n v_{1k}v_{2k}$$

$$\text{Example: } v_1 = \begin{bmatrix} 1 \\ 2 \\ 3 \end{bmatrix} \quad v_2 = \begin{bmatrix} 3 \\ 5 \\ -1 \end{bmatrix} \quad v_1 \cdot v_2 = v_1^T v_2 = 1 \times 3 + 2 \times 5 - 3 \times 1 = 10$$

Matrix Working on a Vector

When a matrix is multiplied by a vector, the result is another vector. Let's say $A \in \mathbb{R}^{m \times n}$ is multiplied by the vector $x \in \mathbb{R}^n$. The result would produce a vector $b \in \mathbb{R}^m$

$$A = \begin{bmatrix} c_1^{(1)} & c_1^{(2)} & \dots & c_1^{(n)} \\ c_2^{(1)} & c_2^{(2)} & \dots & c_2^{(n)} \\ \cdot & \cdot & \dots & \cdot \\ \cdot & \cdot & \dots & \cdot \\ c_m^{(1)} & c_m^{(2)} & \dots & c_m^{(n)} \end{bmatrix} \quad x = \begin{bmatrix} x_1 \\ x_2 \\ \cdot \\ \cdot \\ x_n \end{bmatrix}$$

A consists of n column vectors $c^{(i)} \in \mathbb{R}^{m \times 1} \quad \forall i \in \{1, 2, 3, \dots, n\}$.

$$A = [c^{(1)} c^{(2)} c^{(3)} \dots c^{(n)}]$$

$$b = Ax = [c^{(1)} c^{(2)} c^{(3)} \dots c^{(n)}] \begin{bmatrix} x_1 \\ x_2 \\ \cdot \\ \cdot \\ x_n \end{bmatrix} = x_1 c^{(1)} + x_2 c^{(2)} + \dots + x_n c^{(n)}$$

As we can see, the product is nothing but the linear combination of the column vectors of matrix A , with the components of vector x being the linear coefficients.

The new vector b formed through the multiplication has the same dimension as that of the column vectors of A and stays in the same column space. This is such a beautiful fact; no matter how we combine the column vectors, we can never leave the space spanned by the column vectors.

Now, let's work on an example.

$$A = \begin{bmatrix} 1 & 2 & 3 \\ 4 & 5 & 6 \end{bmatrix} \quad x = \begin{bmatrix} 2 \\ 2 \\ 3 \end{bmatrix} \quad b = Ax = 2 \begin{bmatrix} 1 \\ 4 \end{bmatrix} + 2 \begin{bmatrix} 2 \\ 5 \end{bmatrix} + 3 \begin{bmatrix} 3 \\ 6 \end{bmatrix} = \begin{bmatrix} 15 \\ 36 \end{bmatrix}$$

As we can see, both the column vectors of A and $b \in \mathbb{R}^{2 \times 1}$

Linear Independence of Vectors

A vector is said to be linearly dependent on other vectors if it can be expressed as the linear combination of other vectors.

If $v_1 = 5v_2 + 7v_3$, then v_1, v_2 and v_3 are not linearly independent since at least one of them can be expressed as the sum of other vectors. In general, a set of n vectors $v_1, v_2, v_3, \dots, v_n \in \mathbb{R}^{m \times 1}$ is said to be linearly independent if and only if $a_1v_1 + a_2v_2 + a_3v_3 + \dots + a_nv_n = 0$ implies each of $a_i = 0 \quad \forall i \in \{1, 2, \dots, n\}$.

If $a_1v_1 + a_2v_2 + a_3v_3 + \dots + a_nv_n = 0$ and not all $a_i = 0$, then the vectors are not linearly independent.

Given a set of vectors, the following method can be used to check whether they are linearly independent or not.

$a_1v_1 + a_2v_2 + a_3v_3 + \dots + a_nv_n = 0$ can be written as

$$\begin{bmatrix} v_1 & v_2 & \dots & v_n \end{bmatrix} \begin{bmatrix} a_1 \\ a_2 \\ \cdot \\ \cdot \\ a_n \end{bmatrix} = 0 \text{ where } v_i \in \mathbb{R}^{m \times 1} \quad \forall i \in \{1, 2, \dots, n\}, \quad \begin{bmatrix} a_1 \\ a_2 \\ \cdot \\ \cdot \\ a_n \end{bmatrix} \in \mathbb{R}^{n \times 1}$$

Solving for $[a_1 \ a_2 \ \dots \ a_n]^T$, if the only solution we get is the zero vector, then the set of vectors v_1, v_2, \dots, v_n is said to be linearly independent.

If a set of n vectors $v_i \in \mathbb{R}^{m \times 1}$ is linearly independent, then those vectors span the whole n -dimensional space. In other words, by taking linear combinations of the n vectors, one can produce all possible vectors in the n -dimensional space. If the n vectors are not linearly independent, they span only a subspace within the n -dimensional space.

To illustrate this fact, let us take vectors in three-dimensional space, as illustrated in Figure 1-5.

If we have a vector $v_1 = [1 \ 2 \ 3]^T$, we can span only one dimension in the three-dimensional space

because all the vectors that can be formed with this vector would have the same direction as that of v_1 , with the magnitude being determined by the scalar multiplier. In other words, each vector would be of the form a_1v_1 .

Now, let's take another vector $v_2 = [5 \ 9 \ 7]^T$, whose direction is not the same as that of v_1 . So, the span of the two vectors $Span(v_1, v_2)$ is nothing but the linear combination of v_1 and v_2 . With these two vectors, we can form any vector of the form $av_1 + bv_2$ that lies in the plane of the two vectors. Basically, we will span a two-dimensional subspace within the three-dimensional space. The same is illustrated in the following diagram.

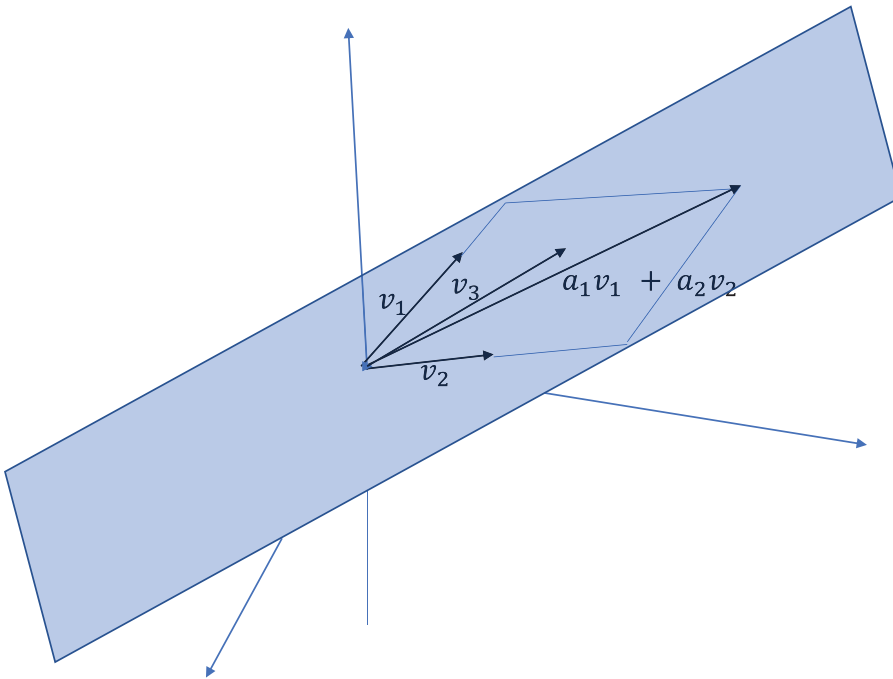

Figure 1-5. A two-dimensional subspace spanned by v_1 and v_2 in a three-dimensional vector space

Let's us add another vector $v_3 = [4\ 8\ 1]^T$ to our vector set. Now, if we consider the $Span(v_1, v_2, v_3)$, we can form any vector in the three-dimensional plane. You take any three-dimensional vector you wish, and it can be expressed as a linear combination of the preceding three vectors.

These three vectors form a basis for the three-dimensional space. Any three linearly independent vectors would form a basis for the three-dimensional space. The same can be generalized for any n -dimensional space.

If we had taken a vector v_3 , which is a linear combination of v_1 and v_2 , then it wouldn't have been possible to span the whole three-dimensional space. We would have been confined to the two-dimensional subspace spanned by v_1 and v_2 .

Rank of a Matrix

One of the most important concepts in linear algebra is the rank of a matrix. The rank of a matrix is the number of linearly independent column vectors or row vectors. The number of independent columns vectors would always be equal to the number of independent row vectors for a matrix.

Example - Consider the matrix $A = \begin{bmatrix} 1 & 3 & 4 \\ 2 & 5 & 7 \\ 3 & 7 & 10 \end{bmatrix}$

The column vectors $\begin{bmatrix} 1 \\ 2 \\ 3 \end{bmatrix}$ and $\begin{bmatrix} 3 \\ 5 \\ 7 \end{bmatrix}$ are linearly independent. However, $\begin{bmatrix} 4 \\ 7 \\ 10 \end{bmatrix}$ is not linearly independent

since it's the linear combination of the other two column vectors; i.e., $\begin{bmatrix} 4 \\ 7 \\ 10 \end{bmatrix} = \begin{bmatrix} 1 \\ 2 \\ 3 \end{bmatrix} + \begin{bmatrix} 3 \\ 5 \\ 7 \end{bmatrix}$. Hence, the rank of

the matrix is 2 since it has two linearly independent column vectors.

As the rank of the matrix is 2, the column vectors of the matrix can span only a two-dimensional subspace inside the three-dimensional vector space. The two-dimensional subspace is the one that can be

formed by taking the linear combination of $\begin{bmatrix} 1 \\ 2 \\ 3 \end{bmatrix}$ and $\begin{bmatrix} 3 \\ 5 \\ 7 \end{bmatrix}$.

A few important notes:

- A square matrix $A \in \mathbb{R}^{n \times n}$ is said to be full rank if the rank of A is n . A square matrix of rank n implies that all the n column vectors and even the n row vectors for that matter are linearly independent, and hence it would be possible to span the whole n -dimensional space by taking the linear combination of the n column vectors of the matrix A .
- If a square matrix $A \in \mathbb{R}^{n \times n}$ is not full rank, then it is a singular matrix; i.e., all its column vectors or row vectors are not linearly independent. A singular matrix has an undefined matrix inverse and zero determinant.

Identity Matrix or Operator

A matrix $I \in \mathbb{R}^{n \times n}$ is said to be an identity matrix or operator if any vector or matrix when multiplied by I remains unchanged. A 3×3 identity matrix is given by

$$I = \begin{bmatrix} 1 & 0 & 0 \\ 0 & 1 & 0 \\ 0 & 0 & 1 \end{bmatrix} \in \mathbb{R}^{3 \times 3}$$

Let's say we take the vector $v = [2\ 3\ 4]^T$

$$Iv = \begin{bmatrix} 1 & 0 & 0 \\ 0 & 1 & 0 \\ 0 & 0 & 1 \end{bmatrix} \begin{bmatrix} 2 \\ 3 \\ 4 \end{bmatrix} = \begin{bmatrix} 2 \\ 3 \\ 4 \end{bmatrix}$$

Similarly, let's say we have a matrix $A = \begin{bmatrix} 1 & 2 & 3 \\ 4 & 5 & 6 \\ 7 & 8 & 9 \end{bmatrix}$

The matrices AI and IA are both equal to matrix A . Hence, the matrix multiplication is commutative when one of the matrices is an identity matrix.

Determinant of a Matrix

A determinant of a square matrix A is a number and is denoted by $\det(A)$. It can be interpreted in several ways. For a matrix $A \in \mathbb{R}^{n \times n}$ the determinant denotes the n -dimensional volume enclosed by the n row vectors of the matrix. For the determinant to be non-zero, all the column vectors or the row vectors of A should be linearly independent. If the n row vectors or column vectors are not linearly independent, then they don't span the whole n -dimensional space, but rather a subspace of dimension less than n , and hence the n -dimensional volume is zero. For a matrix $A \in \mathbb{R}^{2 \times 2}$ the determinant is expressed as

$$A = \begin{bmatrix} a_{11} & a_{12} \\ a_{21} & a_{22} \end{bmatrix} \in \mathbb{R}^{2 \times 2}$$

$$\det(A) = \begin{vmatrix} a_{11} & a_{12} \\ a_{21} & a_{22} \end{vmatrix} = a_{11}a_{22} - a_{12}a_{21}$$

Similarly, for a matrix $B \in \mathbb{R}^{3 \times 3}$ the determinant of the matrix is given by

$$B = \begin{bmatrix} a_{11} & a_{12} & a_{13} \\ a_{21} & a_{22} & a_{23} \\ a_{31} & a_{32} & a_{33} \end{bmatrix} \in \mathbb{R}^{3 \times 3}$$

$$\det(B) = a_{11} \begin{vmatrix} a_{22} & a_{23} \\ a_{32} & a_{33} \end{vmatrix} - a_{12} \begin{vmatrix} a_{21} & a_{23} \\ a_{31} & a_{33} \end{vmatrix} + a_{13} \begin{vmatrix} a_{21} & a_{22} \\ a_{31} & a_{32} \end{vmatrix}$$

$$\text{where } \det \left(\begin{bmatrix} a_{22} & a_{23} \\ a_{32} & a_{33} \end{bmatrix} \right) = \begin{vmatrix} a_{22} & a_{23} \\ a_{32} & a_{33} \end{vmatrix}$$

The method for determinant computation can be generalized to $\mathbb{R}^{n \times n}$ matrices. Treating B as an n -dimensional matrix, its determinant can be expressed as

$$\det(B) = \begin{bmatrix} a_{11 \times} & & & \\ & a_{22} & a_{23} & \\ & a_{32} & a_{33} & \\ & & & \end{bmatrix} - \begin{bmatrix} & a_{12 \times} & & \\ a_{21} & & a_{23} & \\ a_{31} & & a_{33} & \\ & & & \end{bmatrix} + \begin{bmatrix} & & a_{13 \times} & \\ a_{21} & a_{22} & & \\ a_{31} & a_{32} & & \end{bmatrix}$$

For example, the determinant of the matrix $A = \begin{bmatrix} 6 & 1 & 1 \\ 4 & -2 & 5 \\ 2 & 8 & 7 \end{bmatrix}$ can be computed as follows:

$$\begin{aligned}
 \det(A) &= \begin{bmatrix} 6 \times & & \\ & -2 & 5 \\ & 8 & 7 \end{bmatrix} - \begin{bmatrix} & & 1 \times \\ & 4 & 5 \\ 2 & 7 & \end{bmatrix} + \begin{bmatrix} & & & 1 \times \\ & 4 & -2 & \\ & 2 & 8 & \end{bmatrix} \\
 &= 6 \times \begin{vmatrix} -2 & 5 \\ 8 & 7 \end{vmatrix} - 1 \times \begin{vmatrix} 4 & 5 \\ 2 & 7 \end{vmatrix} + 1 \times \begin{vmatrix} 4 & -2 \\ 2 & 8 \end{vmatrix} = 6(-14 - 40) - 1(28 - 10) + 1(32 + 4) \\
 &= 6 \times (-54) - 1(18) + 36 = -306
 \end{aligned}$$

Interpretation of Determinant

As stated earlier, the absolute value of the determinant of a matrix determines the volume enclosed by the row vectors acting as edges.

For a matrix $A \in \mathbb{R}^{2 \times 2}$, it denotes the area of the parallelogram with the two-row vector acting as edges.

For a matrix $A = \begin{bmatrix} a & b \\ c & d \end{bmatrix}$, the $\det(A)$ is equal to the area of the parallelogram with vectors $u = [a \ b]^T$ and $v = [c \ d]^T$ as edges.

Area of the parallelogram = $|u||v|\sin\theta$ where θ is the angle between u and v (see Figure 1-6).

$$= \sqrt{a^2 + b^2} \sqrt{c^2 + d^2} \frac{(ad - bc)}{\sqrt{a^2 + b^2} \sqrt{c^2 + d^2}} = (ad - bc)$$

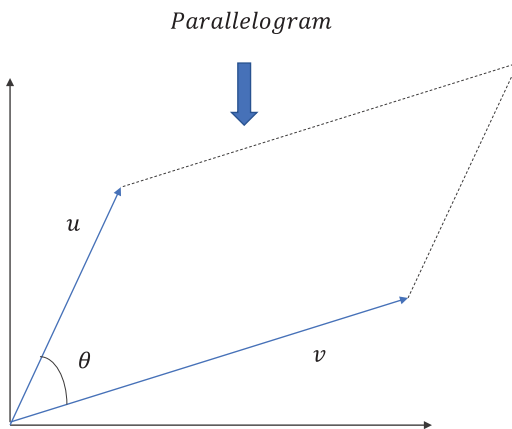

Figure 1-6. Parallelogram formed by two vectors

Similarly, for a matrix $B \in \mathbb{R}^{3 \times 3}$, the determinant is the volume of the parallelepiped with the three-row vectors as edges.

Inverse of a Matrix

An inverse of a square matrix $A \in \mathbb{R}^{n \times n}$ is denoted by A^{-1} and produces the identity matrix $I \in \mathbb{R}^{n \times n}$ when multiplied by A .

$$AA^{-1} = A^{-1}A = I$$

Not all square matrices have inverses for A . The formula for computing the inverse of A is as follows:

$$A^{-1} = \frac{\text{adjoint}(A)}{\det(A)} = \frac{(\text{cofactor matrix of } A)^T}{\det(A)}$$

If a square matrix $A \in \mathbb{R}^{n \times n}$ is singular—i.e., if A doesn't have n independent column or row vectors—then the inverse of A doesn't exist. This is because for a singular matrix $\det(A) = 0$ and hence the inverse becomes undefined.

$$A = \begin{bmatrix} a & b & c \\ d & e & f \\ g & h & i \end{bmatrix}$$

Let the elements of A be represented by a_{ij} , where i represents the row number and j the column number for an element.

Then, the cofactor for $a_{ij} = (-1)^{i+j} d_{ij}$, where d_{ij} is the determinant of the matrix formed by deleting the row i and the column j from A .

$$\text{The cofactor for the element } a = (-1)^{1+1} \begin{vmatrix} e & f \\ h & i \end{vmatrix} = ei - fh.$$

$$\text{Similarly, the cofactor for element } b = (-1)^{1+2} \begin{vmatrix} d & f \\ g & i \end{vmatrix} = -(di - fg).$$

Once the cofactor matrix is formed, the transpose of the cofactor matrix would give us $\text{adjoint}(A)$. The $\text{adjoint}(A)$ divided by the $\det(A)$ gives A^{-1} .

For example, the inverse matrix of $A = \begin{bmatrix} 4 & 3 \\ 3 & 2 \end{bmatrix}$ can be computed as follows:

$$\text{Cofactor matrix of } A = \begin{bmatrix} 1(2) & -1(3) \\ -1(3) & 1(4) \end{bmatrix} = \begin{bmatrix} 2 & -3 \\ -3 & 4 \end{bmatrix}$$

$$\det(A) = \begin{vmatrix} 4 & 3 \\ 3 & 2 \end{vmatrix} = 8 - 9 = -1 \text{ Therefore, } A^{-1} = \frac{(\text{cofactor matrix of } A)^T}{\det(A)} = \frac{\begin{bmatrix} 2 & -3 \\ -3 & 4 \end{bmatrix}^T}{-1} = \begin{bmatrix} -2 & 3 \\ 3 & -4 \end{bmatrix}.$$

A few rules for inverses of a matrix:

- $(AB)^{-1} = B^{-1}A^{-1}$
- $I^{-1} = I$, where I is the identity matrix

Norm of a Vector

The norm of a vector is a measure of its magnitude. There are several kinds of such norms. The most familiar is the Euclidean norm, defined next. It is also known as the l^2 norm.

For a vector $x \in \mathbb{R}^{n \times 1}$ the l^2 norm is as follows:

$$\|x\|_2 = \left(|x_1|^2 + |x_2|^2 + \dots + |x_n|^2 \right)^{1/2} = (x \cdot x)^{1/2} = (x^T x)^{1/2}$$

Similarly, the l^1 norm is the sum of the absolute values of the vector components.

$$\|x\|_1 = |x_1| + |x_2| + \dots + |x_n|$$

In general, the l^p norm of a vector can be defined as follows when $1 < p < \infty$:

$$\left(|x_1|^p + |x_2|^p + \dots + |x_n|^p \right)^{1/p}$$

When $p \rightarrow \infty$ then the norm is called Supremum norm and is defined as follows:

$$\begin{aligned} \lim_{p \rightarrow \infty} \|x\|_p &= \lim_{p \rightarrow \infty} \left(|x_1|^p + |x_2|^p + \dots + |x_n|^p \right)^{1/p} \\ &= \max(x_1, x_2, \dots, x_n) \end{aligned}$$

In Figure 1-7, the unit norm curves have been plotted for l^1 , l^2 and Supremum norm.

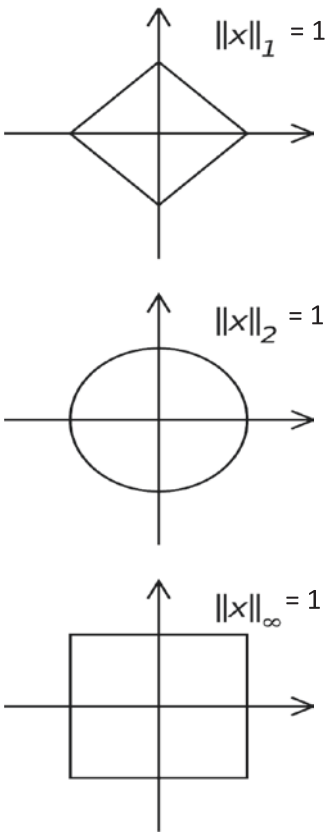

Figure 1-7. Unit l^1 , l^2 and Supremum norms of vectors $\in \mathbb{R}^{2 \times 1}$

Generally, for machine learning we use both l^2 and l^1 norms for several purposes. For instance, the least square cost function that we use in linear regression is the l^2 norm of the error vector; i.e., the difference between the actual target-value vector and the predicted target-value vector. Similarly, very often we would have to use regularization for our model, with the result that the model doesn't fit the training data very well and fails to generalize to new data. To achieve regularization, we generally add the square of either the l^2 norm or the l^1 norm of the parameter vector for the model as a penalty in the cost function for the model. When the l^2 norm of the parameter vector is used for regularization, it is generally known as Ridge Regularization, whereas when the l^1 norm is used instead it is known as Lasso Regularization.

Pseudo Inverse of a Matrix

If we have a problem $Ax = b$ where $A \in \mathbb{R}^{m \times n}$ and $b \in \mathbb{R}^{m \times 1}$ are provided and we are required to solve for $x \in \mathbb{R}^{n \times 1}$, we can solve for x as $x = A^{-1}b$ provided A is not singular and its inverse exists.

However, if $A \in \mathbb{R}^{m \times n}$ —i.e., if A is a rectangular matrix and $m > n$ —then A^{-1} doesn't exist, and hence we can't solve for x by the preceding approach. In such cases, we can get an optimal solution, as $x^* = (A^T A)^{-1} A^T b$. The matrix $(A^T A)^{-1} A^T$ is called the pseudo-inverse since it acts as an inverse to provide the optimal solution. This pseudo-inverse would come up in least square techniques, such as linear regression.

Unit Vector in the Direction of a Specific Vector

Unit vector in the direction of the specific vector is the vector divided by its magnitude or norm. For a Euclidian space, also called an l^2 space, the unit vector in the direction of the vector $x = [3\ 4]^T$ is

$$\frac{x}{\|x\|_2} = \frac{x}{(x^T x)^{1/2}} = \frac{[3\ 4]^T}{5} = [0.6\ 0.8]^T$$

Projection of a Vector in the Direction of Another Vector

Projection of a vector v_1 in the direction of v_2 is the dot product of v_1 with the unit vector in the direction of v_2 .

$\|v_{12}\| = v_1^T u_2$, where $\|v_{12}\|$ is the projection of v_1 onto v_2 and u_2 is the unit vector in the direction of v_2 .

Since $u_2 = \frac{v_2}{\|v_2\|_2}$ as per the definition of a unit vector, the projection can also be expressed as

$$\|v_{12}\| = v_1^T u_2 = v_1^T \frac{v_2}{\|v_2\|_2} = v_1^T \frac{v_2}{(v_2^T v_2)^{1/2}}$$

For example, the projection of the vector $[1\ 1]^T$ in the direction of vector $[3\ 4]^T$ is the dot product of $[1\ 1]^T$ with the unit vector in the direction of $[3\ 4]^T$; i.e., $[0.6\ 0.8]^T$ as computed earlier.

The required projection = $[1\ 1]^T \begin{bmatrix} 0.6 \\ 0.8 \end{bmatrix} = 1 \times 0.6 + 1 \times 0.8 = 1.4$.

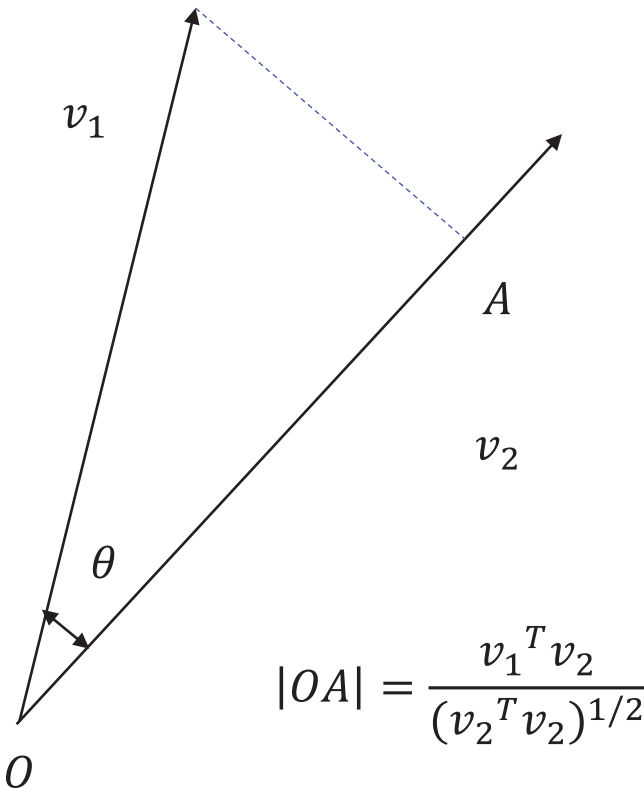

Figure 1-8. The length of the projection of the vector v_1 onto v_2

In Figure 1-8, the length of the line segment OA gives the length of the projection of the vector v_1 onto v_2 .

Eigen Vectors

Here we come to one of the most important concepts in linear algebra—Eigen vectors and Eigen values. Eigen values and Eigen vectors come up in several areas of machine learning. For example, the principal components in principal-component analysis are the Eigen vectors of the covariance matrix, while the Eigen values are the covariances along the principal components. Similarly, in Google’s page-rank algorithm the vector of the page-rank score is nothing but an Eigen vector of the page transition probability matrix corresponding to the Eigen value of 1.

A matrix works on a vector as an operator. The operation of the matrix on the vector is to transform the vector into another vector whose dimensions might or might not be same as the original vector based on the matrix dimension.

When a matrix $A \in \mathbb{R}^{n \times n}$ works on a vector $x \in \mathbb{R}^{n \times 1}$, we again get back a vector $Ax \in \mathbb{R}^{n \times 1}$. Generally, the magnitude as well as the direction of the new vector is different from that of the original vector. If in such a scenario the newly generated vector has the same direction or exactly the opposite direction as that of the original vector, then any vector in such a direction is called an Eigen vector. The magnitude by which the vector gets stretched is called the Eigen value (see Figure 1-9).

$$Ax = \lambda x$$

where A is the matrix operator operating on the vector v by multiplication, which is also the Eigen vector, and λ is the Eigen value.

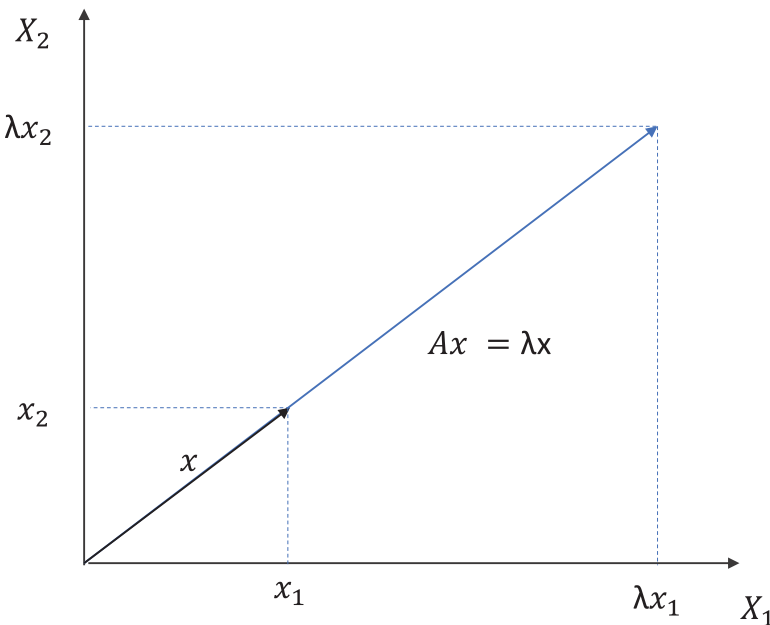

Figure 1-9. Eigen vector unaffected by the matrix transformation A

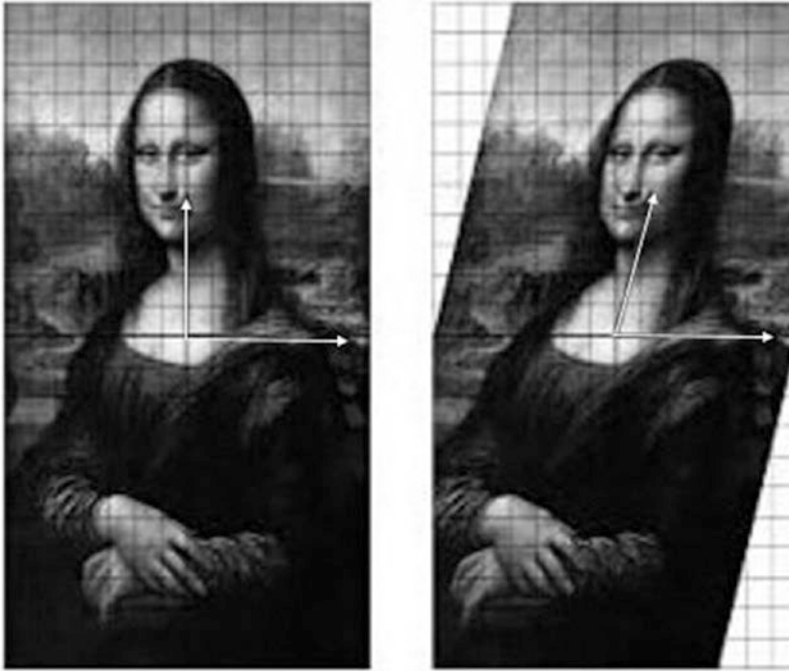

Figure 1-10. The famous *Mona Lisa* image has a transformation applied to the vector space of pixel location

As we can see from Figure 1-10, the pixels along the horizontal axis represented by a vector have changed direction when a transformation to the image space is applied, while the pixel vector along the horizontal direction hasn't changed direction. Hence, the pixel vector along the horizontal axis is an Eigen vector to the matrix transformation being applied to the *Mona Lisa* image.

Characteristic Equation of a Matrix

The roots of the characteristic equation of a matrix $A \in \mathbb{R}^{n \times n}$ gives us the Eigen values of the matrix. There would be n Eigen values corresponding to n Eigen vectors for a square matrix of order n .

For an Eigen vector $v \in \mathbb{R}^{n \times 1}$ corresponding to an Eigen value of λ , we have

$$Av = \lambda v$$

$$\Rightarrow (A - \lambda I)v = 0$$

Now, v being an Eigen vector is non-zero, and hence $(A - \lambda I)$ must be singular for the preceding to hold true.

For $(A - \lambda I)$ to be singular, $\det(A - \lambda I) = 0$, which is the characteristics equation for matrix A . The roots of the characteristics equation gives us the Eigen values. Substituting the Eigen values in the $Av = \lambda v$ equation and then solving for v gives the Eigen vector corresponding to the Eigen value.

For example, the Eigen values and Eigen vectors of the matrix

$$A = \begin{bmatrix} 0 & 1 \\ -2 & -3 \end{bmatrix}$$

can be computed as seen next.

The characteristics equation for the matrix A is $\det(A - \lambda I) = 0$.

$$\begin{vmatrix} -\lambda & 1 \\ -2 & -3-\lambda \end{vmatrix} = 0 \Rightarrow \lambda^2 + 3\lambda + 2 = 0 \Rightarrow \lambda = -2, -1$$

The two Eigen values are -2 and -1 .

Let the Eigen vector corresponding to the Eigen value of -2 be $u = [a \ b]^T$.

$$\begin{bmatrix} 0 & 1 \\ -2 & -3 \end{bmatrix} \begin{bmatrix} a \\ b \end{bmatrix} = -2 \begin{bmatrix} a \\ b \end{bmatrix}$$

This gives us the following two equations:

$$0a + 1b = -2a \Rightarrow 2a + b = 0 \quad - \quad (1)$$

$$-2a - 3b = -2b \Rightarrow 2a + b = 0 \quad - \quad (2)$$

Both the equations are the same; i.e., $2a + b = 0 \Rightarrow \frac{a}{b} = \frac{1}{-2}$.

Let $a = k_1$ and $b = -2k_1$, where k_1 is a constant.

Therefore, the Eigen vector corresponding to the Eigen value -2 is $u = k_1 \begin{bmatrix} 1 \\ -2 \end{bmatrix}$.

Using the same process, the Eigen vector v corresponding to the Eigen value of -1 is $v = k_2 \begin{bmatrix} 1 \\ -1 \end{bmatrix}$.

One thing to note is that Eigen vectors and Eigen values are always related to a specific operator (in the preceding case, matrix A is the operator) working on a vector space. Eigen values and Eigen vectors are not specific to any vector space.

Functions can be treated as vectors. Let's say we have a function $f(x) = e^{ax}$.

Each of the infinite values of x would be a dimension, and the value of $f(x)$ evaluated at those values would be the vector component along that dimension. So, what we would get is an infinite vector space.

Now, let's look at the differentiator operator.

$$\frac{dy}{dx}(f(x)) = \frac{dy}{dx}(e^{ax}) = ae^{ax}$$

Here, $\frac{dy}{dx}$ is the operator and e^{ax} is an Eigen function with respect to the operator, while a is the corresponding Eigen value.

As expressed earlier, the applications of Eigen vectors and Eigen values are profound and far reaching in almost any domain, and this is true for machine learning as well. To get an idea of how Eigen vectors have influenced modern applications, we will look at the Google page-ranking algorithm in a simplistic setting.

Let us look at the page-ranking algorithm for a simple website that has three pages—A, B, and C—as illustrated in Figure 1-11.

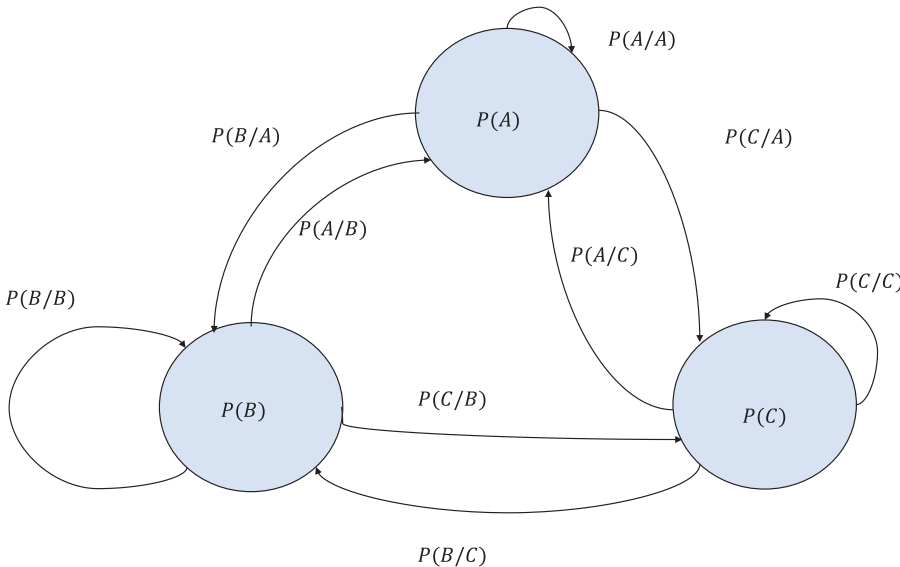

Figure 1-11. Transition probability diagram for three pages A, B, and C

In a web setting, one can jump from one page to another page given that the original page has a link to the next page. Also, a page can self-reference and have a link to itself. So, if a user goes from page A to B because page A references page B, the event can be denoted by B/A . $P(B/A)$ can be computed by the total number of visits to page B from page A divided by the total number of visits to page A. The transition probabilities for all page combinations can be computed similarly. Since the probabilities are computed by normalizing count, the individual probabilities for pages would carry the essence of the importance of the pages.

In the steady state, the probabilities of each page would become constant. We need to compute the steady-state probability of each page based on the transition probabilities.

For the probability of any page to remain constant at steady state, probability mass going out should be equal to probability mass coming in, and each of them—when summed up with probability mass that stays in a page—should equal the probability of the page. In that light, if we consider the equilibrium equation around page A, the probability mass going out of A is $P(B/A)P(A) + P(C/A)P(A)$ whereas the probability mass coming into A is $P(A/B)P(B) + P(A/C)P(C)$. The probability mass $P(A/A)P(A)$ remains at A itself. Hence, at equilibrium the sum of probability mass coming from outside—i.e., $P(A/B)P(B) + P(A/C)P(C)$ —and probability mass remaining at A—i.e., $P(A/A)P(A)$ —should equal $P(A)$, as expressed here:

$$P(A/A)P(A) + P(A/B)P(B) + P(A/C)P(C) = P(A) \quad (1)$$

Similarly, if we consider the equilibrium around pages B and C, the following holds true:

$$P(B/A)P(A) + P(B/B)P(B) + P(B/C)P(C) = P(B) \quad (2)$$

$$P(C/A)P(A) + P(C/B)P(B) + P(C/C)P(C) = P(C) \quad (3)$$

Now comes the linear algebra part. We can arrange the three equations into a matrix working on a vector, as follows:

$$\begin{bmatrix} P(A/A) & P(A/B) & P(A/C) \\ P(B/A) & P(B/B) & P(B/C) \\ P(C/A) & P(C/B) & P(C/C) \end{bmatrix} \begin{bmatrix} P(A) \\ P(B) \\ P(C) \end{bmatrix} = \begin{bmatrix} P(A) \\ P(B) \\ P(C) \end{bmatrix}$$

The transition-probability matrix works on the page-probability vector to produce again the page-probability vector. The page-probability vector, as we can see, is nothing but an Eigen vector to the page-transition-probability matrix, and the corresponding Eigen value for the same is 1.

So, computing the Eigen vector corresponding to the Eigen value of 1 would give us the page-probability vector, which in turn can be used to rank the pages. Several page-ranking algorithms of reputed search engines work on the same principle. Of course, the actual algorithms of the search engines have several modifications to this naïve model, but the underlying concept is the same. The probability vector can be determined through methods such as power iteration, as discussed in the next section.

Power Iteration Method for Computing Eigen Vector

The power iteration method is an iteration technique used to compute the Eigen vector of a matrix corresponding to the Eigen value of largest magnitude.

Let $A \in \mathbb{R}^{n \times n}$ and then let that the n Eigen values in order of magnitude are $\lambda_1 > \lambda_2 > \lambda_3 > \dots > \lambda_n$ and the corresponding Eigen vectors are $v_1 > v_2 > v_3 > \dots > v_n$.

Power iteration starts with a random vector v , which should have some component in the direction of the Eigen vector corresponding to the largest Eigen value; i.e., v_1 .

The approximate Eigen vector in any iteration is given by

$$v^{(k+1)} = \frac{Av^{(k)}}{\|Av^{(k)}\|}$$

After a sufficient number of iterations, $v^{(k+1)}$ converges to v_1 . In every iteration, we multiply the matrix A by the vector obtained from the prior step. If we remove the normalizing of the vector to convert it to a unit vector in the iterative method, we have $v^{(k+1)} = A^k v$.

Let the initial vector v be represented as a combination of the Eigen vectors:

$v = k_1 v_1 + k_2 v_2 + \dots + k_n v_n$ where $k_i \forall i \in \{1, 2, 3, \dots, n\}$ are constants.

$$\begin{aligned} v^{(k+1)} &= A^k v = A^k (k_1 v_1 + k_2 v_2 + \dots + k_n v_n) \\ &= k_1 A^k v_1 + k_2 A^k v_2 + \dots + k_n A^k v_n \\ &= k_1 \lambda_1^k v_1 + k_2 \lambda_2^k v_2 + \dots + k_n \lambda_n^k v_n \\ &= \lambda_1^k \left(k_1 v_1 + k_2 \left(\frac{\lambda_2}{\lambda_1} \right)^k v_2 + \dots + k_n \left(\frac{\lambda_n}{\lambda_1} \right)^k v_n \right) \end{aligned}$$

Now, when k is sufficiently large—i.e., ($k \rightarrow \infty$)—all the terms except the first will vanish since

$$\left(\frac{\lambda_i}{\lambda_1} \right)^k \rightarrow 0 \quad \forall i \in \{2, 3, \dots, n\}$$

Therefore, $v^{(k+1)} = \lambda_1^k k_1 v_1$, which gives us the Eigen vector corresponding to the Eigen value of largest magnitude. The rate of convergence depends on the magnitude of the second-largest Eigen value in comparison to the largest Eigen value. The method converges slowly if the second-largest Eigen value is close in magnitude to the largest one.

■ **Note** In this chapter, I have touched upon the basics of linear algebra so that readers who are not familiar with this subject have some starting point. However, I would suggest the reader to take up linear algebra in more detail in his or her spare time. Renowned Professor Gilbert Strang's book *Linear Algebra and Its Applications* is a wonderful way to get started.

Calculus

In its very simplest form, calculus is a branch of mathematics that deals with differentials and integrals of functions. Having a good understanding of calculus is important for machine learning for several reasons:

- Different machine-learning models are expressed as functions of several variables.
- To build a machine-learning model, we generally compute a cost function for the model based on the data and model parameters, and through optimization of the cost function we derive the model parameters that best explain the given data.

Differentiation

Differentiation of a function generally means the rate of change of a quantity represented by a function with respect to another quantity on which the function is dependent on.

Let's say a particle moves in a one-dimensional plane—i.e., a straight line—and its distance at any specific time is defined by the function $f(t) = 5t^2$.

The velocity of the particle at any specific time would be given by the derivative of the function with respect to time t .

The derivative of the function is defined as $\frac{df(t)}{dt}$ and is generally expressed by the following formulae based on whichever is convenient:

$$\frac{df}{dt} = \lim_{h \rightarrow 0} \frac{f(t+h) - f(t)}{h}$$

or

$$\frac{df}{dt} = \lim_{h \rightarrow 0} \frac{f(t+h) - f(t-h)}{2h}$$

When we deal with a function that is dependent on multiple variables, the derivative of the function with respect to each of the variables keeping the others fixed is called a partial derivative, and the vector of partial derivatives is called the gradient of the function.

Let's say the price z of a house is dependent on two variables: square feet area of the house x and the number of bedrooms y .

$$z = f(x, y)$$

The partial derivative of z with respect to x is represented by

$$\frac{\partial z}{\partial x} = \lim_{h \rightarrow 0} \frac{f(x+h, y) - f(x, y)}{h}$$

Similarly, the partial derivative of z with respect to y is

$$\frac{\partial z}{\partial y} = \lim_{h \rightarrow 0} \frac{f(x, y+h) - f(x, y)}{h}$$

Bear in mind that in a partial derivate, except the variable with respect to which the derivate is being taken, are held constant.

Gradient of a Function

For a function with two variables $z = f(x, y)$, the vector of partial derivatives $\left[\frac{\partial z}{\partial x} \quad \frac{\partial z}{\partial y} \right]^T$ is called the gradient

of the function and is denoted by ∇z . The same can be generalized for a function with n variables. A multivariate function $f(x_1, x_2, \dots, x_n)$ can also be expressed as $f(x)$, where $x = [x_1, x_2, \dots, x_n]^T \in \mathbb{R}^{n \times 1}$. The gradient vector for the multivariate function $f(x)$ with respect to x can be expressed as $\nabla f = \left[\frac{\partial f}{\partial x_1} \quad \frac{\partial f}{\partial x_2} \quad \dots \quad \frac{\partial f}{\partial x_n} \right]^T$.

For example, the gradient of a function with three variables $f(x, y, z) = x + y^2 + z^3$ is given by

$$\nabla f = [1 \ 2y \ 3z^2]^T$$

The gradient and the partial derivatives are important in machine-learning algorithms when we try to maximize or minimize cost functions with respect to the model parameters, since at the maxima and minima the gradient vector of a function is zero. At the maxima and minima of a function, the gradient vector of the function should be a zero vector.

Successive Partial Derivatives

We can have successive partial derivatives of a function with respect to multiple variables. For example, for a function $z = f(x, y)$

$$\frac{\partial}{\partial y} \left(\frac{\partial z}{\partial x} \right) = \frac{\partial^2 z}{\partial y \partial x}$$

This is the partial derivative of z with respect to x first and then with respect to y . Similarly,

$$\frac{\partial}{\partial x} \left(\frac{\partial z}{\partial y} \right) = \frac{\partial^2 z}{\partial x \partial y}$$

If the second derivatives are continuous, the order of partial derivatives doesn't matter and

$$\frac{\partial^2 z}{\partial x \partial y} = \frac{\partial^2 z}{\partial y \partial x}.$$

Hessian Matrix of a Function

The Hessian of a multivariate function is a matrix of second-order partial derivatives. For a function $f(x, y, z)$, the Hessian is defined as follows:

$$Hf = \begin{bmatrix} \frac{\delta^2 f}{\delta x^2} & \frac{\delta^2 f}{\delta x \delta y} & \frac{\delta^2 f}{\delta x \delta z} \\ \frac{\delta^2 f}{\delta y \delta x} & \frac{\delta^2 f}{\delta y^2} & \frac{\delta^2 f}{\delta y \delta z} \\ \frac{\delta^2 f}{\delta z \delta x} & \frac{\delta^2 f}{\delta z \delta y} & \frac{\delta^2 f}{\delta z^2} \end{bmatrix}$$

The Hessian is useful in the optimization problems that we come across so frequently in the machine-learning domain. For instance, in minimizing a cost function to arrive at a set of model parameters, the Hessian is used to get better estimates for the next set of parameter values, especially if the cost function is non-linear in nature. Non-linear optimization techniques, such as Newton's method, Broyden-Fletcher-Goldfarb-Shanno (BFGS), and its variants, use the Hessian for minimizing cost functions.

Maxima and Minima of Functions

Evaluating the maxima and minima of functions has tremendous applications in machine learning. Building machine-learning models relies on minimizing cost functions or maximizing likelihood functions, entropy, and so on in both supervised and unsupervised learning.

Rules for Maxima and Minima for a Univariate Function

- The derivative of $f(x)$ with respect to x would be zero at maxima and minima.
- The second derivative of $f(x)$, which is nothing but the derivative of the first

derivative represented by $\frac{d^2 f(x)}{dx^2}$, needs to be investigated at the point where

the first derivative is zero. If the second derivative is less than zero, then it's a point of maxima, while if it is greater than zero it's a point of minima. If the second derivative turns out to be zero as well, then the point is called a point of inflection.

Let's take a very simple function, $y = f(x) = x^2$. If we take the derivative of the function w.r.t x and set it to zero, we get $\frac{dy}{dx} = 2x = 0$, which gives us $x = 0$. Also, the second derivative $\frac{d^2 y}{dx^2} = 2$. Hence, for all values of x , including $x = 0$, the second derivative is greater than zero and hence $x = 0$ is the minima point for the function $f(x)$.

Let's try the same exercise for $y = g(x) = x^3$.

$\frac{dy}{dx} = 3x^2 = 0$ gives us $x = 0$. The second derivative $\frac{d^2 y}{dx^2} = 6x$, and if we evaluate it at $x = 0$ we get 0. So,

$x = 0$ is neither the minima nor the maxima point for the function $g(x)$. Points at which the second derivative is zero are called points of inflection. At points of inflection, the sign of the curvature changes.

The points at which the derivative of a univariate function is zero or the gradient vector for a multivariate function is a zero vector are called stationary points. They may or may not be points of maxima or minima.

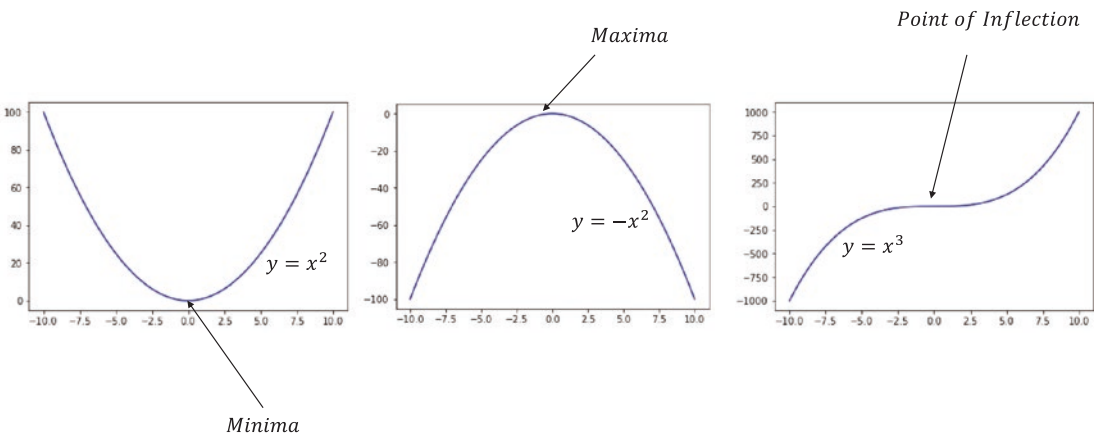

Figure 1-12. Different types of stationary points—maxima, minima, point of inflection

Illustrated in Figure 1-12 are different kinds of stationary points; i.e., maxima, minima, and points of inflection.

Maxima and minima for a multivariate function are a bit more complicated. Let's proceed with an example, and then we will define the rules. We look at a multivariate function with two variables:

$$f(x,y) = x^2y^3 + 3y + x + 5$$

To determine the stationary points, the gradient vector needs to be zero.

$$\begin{bmatrix} \frac{\partial f}{\partial x} & \frac{\partial f}{\partial y} \end{bmatrix}^T = \begin{bmatrix} 0 \\ 0 \end{bmatrix}$$

Setting $\frac{\partial f}{\partial x}$ and $\frac{\partial f}{\partial y}$ to zero, we get:

$$\frac{\partial f}{\partial x} = 2xy^3 + 1 = 0, \quad \frac{\partial f}{\partial y} = 3x^2y^2 + 3 = 0$$

We need to compute the Hessian as well:

$$\frac{\partial^2 f}{\partial x^2} = f_{xx} = 2y^3,$$

$$\frac{\partial^2 f}{\partial y^2} = f_{yy} = 6x^2y,$$

$$\frac{\partial^2 f}{\partial x \partial y} = f_{xy} = 6xy^2$$

$$\frac{\partial^2 f}{\partial y \partial x} = f_{yx} = 6xy^2$$

For functions with continuous second derivatives, $f_{xy} = f_{yx}$.

Let's say the gradient is zero at $(x = a, y = b)$:

- If $f_{xx}f_{yy} - (f_{xy})^2 < 0$ at $(x = a, y = b)$ then $(x = a, y = b)$ is a saddle point.
- If $f_{xx}f_{yy} - (f_{xy})^2 > 0$ at $(x = a, y = b)$ then $(x = a, y = b)$ is an extremum point; i.e., maxima or minima exists.
 - a) If $f_{xx} < 0$ and $f_{yy} < 0$ at $(x = a, y = b)$ then $f(x, y)$ has the maximum at $(x = a, y = b)$.
 - b) If $f_{xx} > 0$ and $f_{yy} > 0$ at $(x = a, y = b)$ then $f(x, y)$ has the minimum at $(x = a, y = b)$.
- If $f_{xx}f_{yy} - (f_{xy})^2 = 0$ then more advanced methods are required to classify the stationary point correctly.

For a function with n variables, the following are the guidelines for checking for the maxima, minima, and saddle points of a function:

- Computing the gradient and setting it to zero vector would give us the list of stationary points.
- For a stationary point $x_0 \in \mathbb{R}^{n \times 1}$, if the Hessian matrix of the function at x_0 has both positive and negative eigen values, then x_0 is a saddle point. If the eigen values of the Hessian matrix are all positive then the stationarity point is a local minima where as if the eigen values are all negative then the stationarity point is a local maxima.

Local Minima and Global Minima

Functions can have multiple minima at which the gradient is zero, each of which is called a local minima point. The local minima at which the function has the minimum value is called the global minima. The same applies for maxima. Maxima and minima of a function are derived by optimization methods. Since closed-form solutions are not always available or are computationally intractable, the minima and maxima are most often derived through iterative approaches, such as gradient descent, gradient ascent, and so forth. In the iterative way of deriving minima and maxima, the optimization method may get stuck in a local minima or maxima and be unable to reach the global minima or maxima. In iterative methods, the algorithm utilizes the gradient of the function at a point to get to a more optimal point. When traversing a series of points in this fashion, once a point with a zero gradient is encountered, the algorithm stops assuming the desired minima or maxima is reached. This works well when there is a global minima or maxima for the function. Also, the optimization can get stuck at a saddle point too. In all such cases, we would have a suboptimal model.

Illustrated in Figure 1-13 are global and local minima as well as global and local maxima of a function.

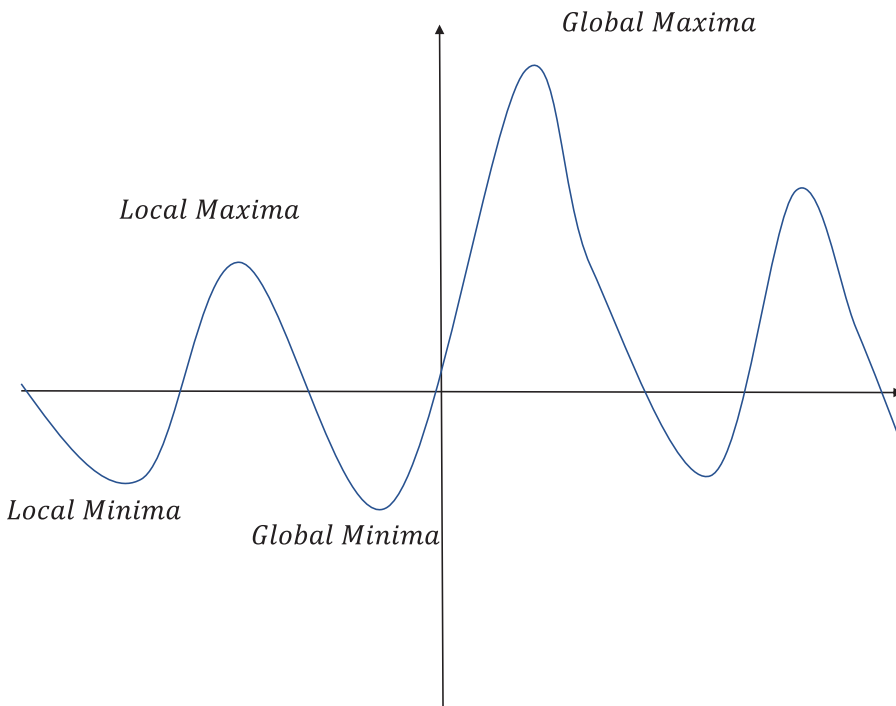

Figure 1-13. Local and global minima/maxima

Positive Semi-Definite and Positive Definite

A square matrix $A \in \mathbb{R}^{n \times n}$ is positive semi-definite if for any non-zero vector $x \in \mathbb{R}^{n \times 1}$ the expression $x^T A x \geq 0$. The matrix A is positive definite if the expression $x^T A x > 0$. All the Eigen values for a positive semi-definite matrix should be non-negative, whereas for a positive definite matrix the Eigen values should be positive. For example, if we consider A as the 2×2 identity matrix—i.e., $\begin{bmatrix} 1 & 0 \\ 0 & 1 \end{bmatrix}$ —then it is positive definite since both of its Eigen values—i.e., 1,1—are positive. Also, if we compute $x^T A x$, where $x = [x_1 \ x_2]^T$, we get $x^T A x = x_1^2 + x_2^2$, which is always greater than zero for non-zero vector x , which confirms that A is a positive definite matrix.

Convex Set

A set of points is called convex if, given any two points x and y belonging to the set, all points joining the straight line from x to y also belong to the set. In Figure 1-14, a convex set and a non-convex set are illustrated.

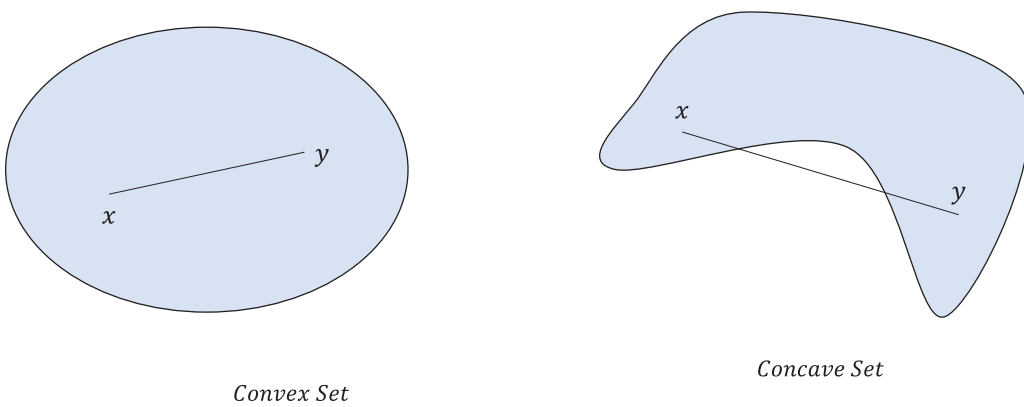

Figure 1-14. Convex and non-convex set

Convex Function

A function $f(x)$ defined on a convex set D , where $x \in \mathbb{R}^{n \times 1}$ and D is the domain, is said to be convex if the straight line joining any two points in the function lies above or on the graph of the function. Mathematically, this can be expressed as the following:

$$f(tx + (1-t)y) \leq tf(x) + (1-t)f(y) \quad \forall x, y \in D, \forall t \in [0,1]$$

For a convex function that is twice continuously differentiable, the Hessian matrix of the function evaluated at each point in the domain D of the function should be positive semi-definite; i.e., for any vector $x \in \mathbb{R}^{n \times 1}$,

$$x^T Hx \geq 0$$

A convex function has the local minima as its global minima. Bear in mind that there can be more than one global minima, but the value of the function would be same at each of the global minima for a convex function.

In Figure 1-15, a convex function $f(x)$ is illustrated. As we can see, the $f(x)$ clearly obeys the property of convex functions stated earlier.

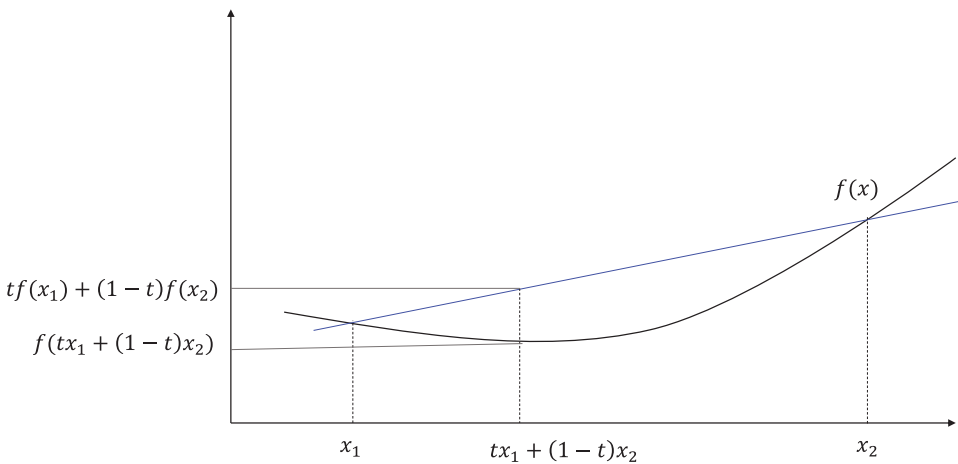

Figure 1-15. Convex function illustration

Non-convex Function

A non-convex function can have many local minima, all of which are not global minima.

In any machine-learning model building process where we try to learn the model parameters by minimizing a cost function, we prefer the cost function to be convex, since with a proper optimization technique we would attain the global minima for sure. For a non-convex cost function, there is a high chance that the optimization technique will get stuck at a local minima or a saddle point, and hence it might not attain its global minima.

Multivariate Convex and Non-convex Functions Examples

Since we would be dealing with high-dimensional functions in deep learning, it makes sense to look at convex and non-convex functions with two variables.

$f(x, y) = 2x^2 + 3y^2 - 5$ is a convex function with minima at $x=0, y=0$, and the minimum value of $f(x, y)$ at $(x=0, y=0)$ is -5 . The function is plotted in Figure 1-16 for reference.

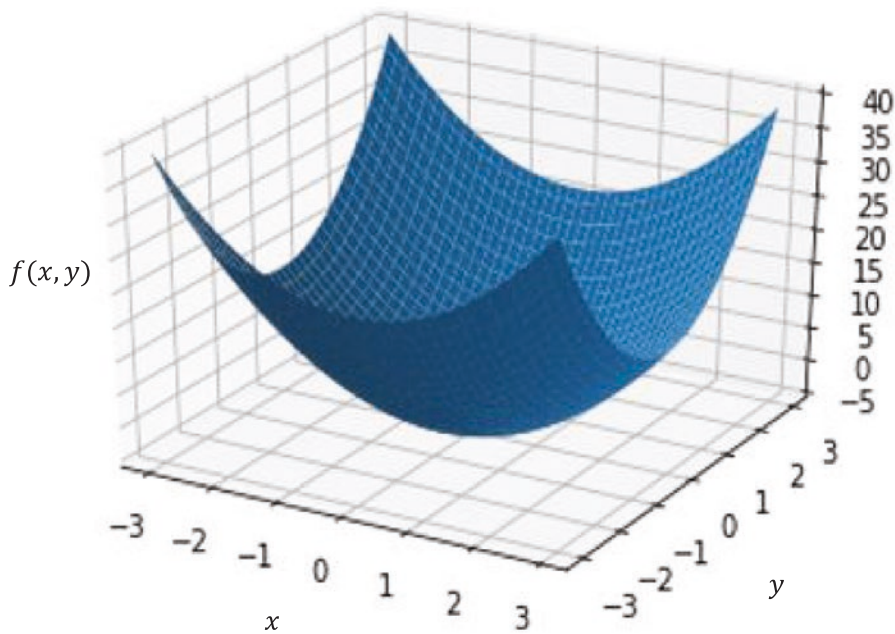

Figure 1-16. Plot of the convex function $2x^2 + 3y^2 - 5$

Now, let's consider the function $f(x,y) = \log x / y \forall x > 0, y > 0$.

The preceding is a non-convex function, and the easiest way to verify this is to look at the Hessian matrix for the function:

$$\text{Hessian } H = \begin{bmatrix} -\frac{1}{x^2} & 0 \\ 0 & \frac{1}{y^2} \end{bmatrix}$$

The Eigen values of the Hessian are $-\frac{1}{x^2}$ and $\frac{1}{y^2} \cdot -\frac{1}{x^2}$ would always be negative for real x . Hence, the Hessian is not positive semi-definite, making the function non-convex.

We can see in Figure 1-17 that the plot of the function $\log(x/y)$ looks non-convex.

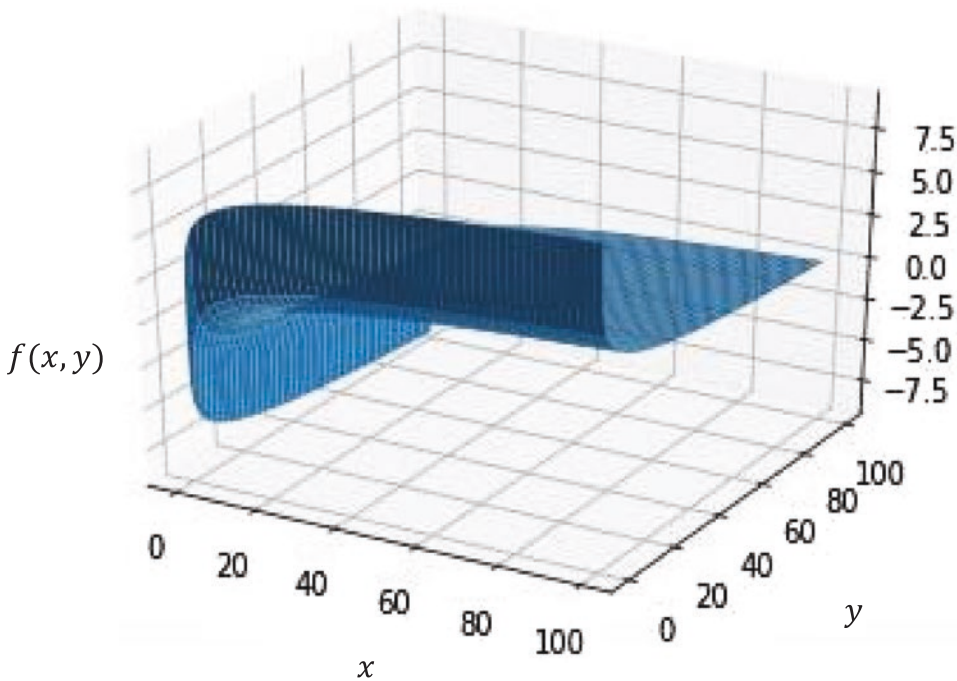

Figure 1-17. Plot of the Non-Convex function $\log(x/y)$

Linear regression through least squares or logistic regression through log-loss cost functions (binary cross entropy) are all convex optimization problems, and hence the model parameters learned through optimization are a global minima solution. Similarly, in SVM the cost function that we optimize is convex.

Whenever there are hidden layers or latent factors involved in any model, the cost function tends to be non-convex in nature. A neural network with hidden layers gives non-convex cost or error surface irrespective of whether we are solving regression or classification problems.

Similarly, in K-means clustering the introduction of clusters makes the cost function to optimize a non-convex cost function. Intelligent methods need to be adopted for non-convex cost functions so that we achieve some local minima that are good enough if it is not possible to reach the global minima.

Parameter initialization becomes very important when dealing with a non-convex problem. The closer the initialized parameters are to the global minima or to some acceptable local minima the better. For k means, one method of ensuring that the solution is not suboptimal is to run the k -means algorithm several times with different randomly initialized model parameters; i.e., the cluster centroids. We may then take the one that reduces the sum of the intra-cluster variances the most. For neural networks, one needs to use advanced gradient-descent methods involving momentum parameters to come out of the local minima and move forward. We will get to gradient-based optimization methods for neural networks in more detail later in this book.

Taylor Series

Any function can be expressed as an infinite sum by considering the value of the function and its derivatives at a specific point. Such an expansion of the function is called Taylor Series expansion. The Taylor Series expansion of a univariate function around a point x can be expressed as follows:

$$f(x+h) = f(x) + hf'(x) + \frac{1}{2!}h^2 f''(x) + \frac{1}{3!}h^3 f'''(x) + \dots + \frac{1}{n!}h^n f^n(x) + \dots$$

where $f^n(x)$ is the n th derivative of the function $f(x)$ and $n!$ denotes the factorial of the number n . The term h has the same dimension as that of x , and both h, x are scalars.

- If $f(x)$ is a constant function, then all the derivatives are zero and $f(x+h)$ and $f(x)$ are same.
- If the function is linear around the neighborhood of x , then for any point $(x+h)$ that lies in the region of the linearity, $f(x+h) = f(x) + hf'(x)$.
- If the function is quadratic around the neighborhood of x , then for any point $(x+h)$ that lies in the quadratic zone, $f(x+h) = f(x) + hf'(x) + \frac{1}{2!}h^2 f''(x)$.
- Taylor Series expansion becomes very important in iterative methods such as gradient-descent methods and Newton's methods for optimization as well as in numerical methods for integration and differentiation.

Taylor Series expansion for multivariate functions around a point $x \in \mathbb{R}^{n \times 1}$ can be expressed as

$$f(x+\Delta x) = f(x) + \Delta x^T \nabla f(x) + \frac{1}{2} \Delta x^T \nabla^2 f(x) \Delta x + \text{higher order terms}$$

where $\nabla f(x)$ is the gradient vector and $\nabla^2 f(x)$ is the Hessian matrix for the function $f(x)$.

Generally, for practical purposes, we don't go beyond second-order Taylor Series expansion in machine-learning applications since in numerical methods they are hard to compute. Even for second-order expansion computing the Hessian is cost intensive and hence several second-order optimization methods rely on computing the approximate Hessians from gradients instead of evaluating them directly. Please note that the third-order derivatives object $\nabla^3 f(x)$ would be a three-dimensional tensor.

Probability

Before we go on to probability, it is important to know what a random experiment and a sample space are.

In many types of work, be it in a research laboratory or an otherwise, repeated experimentation under almost identical conditions is a standard practice. For example, a medical researcher may be interested in the effect of a drug that is to be launched, or an agronomist might want to study the effect of chemical fertilizer on the yield of a specific crop. The only way to get information about these interests is to conduct experiments. At times, we might not need to perform experiments, as the experiments are conducted by nature and we just need to collect the data.

Each experiment would result in an outcome. Suppose the outcome of the experiments cannot be predicted with absolute certainty. However, before we conduct the experiments, suppose we know the set of all possible outcomes. If such experiments can be repeated under almost the same conditions, then the experiment is called a random experiment, and the set of all possible outcomes is called the sample space.

Do note that sample space is only the set of outcomes we are interested in. A throw of dice can have several outcomes. One is the set of outcomes that deals with the face on which the dice lands. The other possible set of outcomes can be the velocity with which the dice hits the floor. If we are only interested in the face on which the dice lands, then our sample space is $\Omega = \{1, 2, 3, 4, 5, 6\}$; i.e., the face number of the dice.

Let's continue with the experiment of throwing the dice and noting down the face on which it lands as the outcome. Suppose we conduct the experiment n times, and face 1 turns up m times. Then, from the experiment, we can say that the probability of the event of the dice face's being 1 is equal to the number of experiments in which the dice face that turned up was 1 divided by the total number of experiments conducted; i.e., $P(x=1) = \frac{m}{n}$, where x denotes the number on the face of the dice.

Let's suppose we are told that a dice is fair. What is the probability of the number coming up as 1?

Well, given that the dice is fair and that we have no other information, most of us would believe in the near symmetry of the dice such that it would produce 100 faces with number 1 if we were to throw the dice 600 times. This would give us the probability as $\frac{1}{6}$.

Now, let's say we have gathered some 1000 data points about the numbers on the dice head during recent rolls of the dice. Here are the statistics:

1 → 200 times

2 → 100 times

3 → 100 times

4 → 100 times

5 → 300 times

6 → 200 times

In this case, you would come up with the probability of the dice face's being 1 as $P(x=1) = 200/1000 = 0.2$. The dice is either not symmetric or is biased.

Unions, Intersection, and Conditional Probability

$P(A \cup B)$ = Probability of the event A or event B or both

$P(A \cap B)$ = Probability of event A and event B

$P(A/B)$ = Probability of event A given that B has already occurred.

$$P(A \cap B) = P(A/B)P(B) = P(B/A)P(A)$$

From now on, we will drop the notation of A intersection B as $A \cap B$ and will denote it as AB for ease of notation.

$$P(A - B) = P(A) - P(AB)$$

All the preceding proofs become easy when we look at the Venn Diagram of the two events A and B as represented in Figure 1-18.

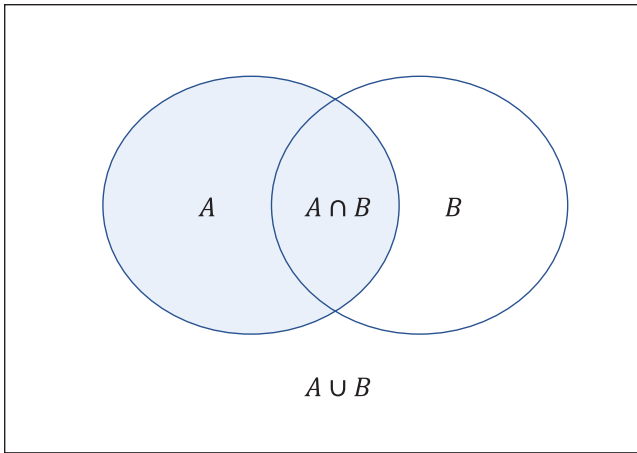

Figure 1-18. Venn diagram of two events A and B showing the union and intersection of the two events

Let's say there are n occurrences of an experiment in which A has occurred n_1 times, B has occurred n_2 times, and A and B together have occurred m times.

Let's represent this with a Venn diagram.

$P(A \cup B)$ can be represented by the sum of the probability of the three disjointed events: $(A - B)$, $(B - A)$, and AB .

$$\begin{aligned} P(A \cup B) &= P(A - B) + P(B - A) + P(AB) \\ &= P(A) - P(AB) + P(B) - P(AB) + P(AB) \\ &= P(A) + P(B) - P(AB) \end{aligned}$$

$P(A/B)$ is the probability of A given that B has already occurred. Given that B has already happened in n_2 ways, the event A is restricted to the event AB that can occur in m different ways. So, the probability of A given B can be expressed as follows:

$$P(A/B) = \frac{m}{n_2}$$

Now, $\frac{m}{n_2}$ can be written as $\frac{\frac{m}{n}}{\frac{n_2}{n}} = \frac{P(AB)}{P(B)}$.

Hence, $P(A/B) = P(AB)/P(B) \Rightarrow P(AB) = P(B)P(A/B)$.

Similarly, if we consider $P(B/A)$, then the relation $P(AB) = P(A)P(B/A)$ also holds true.

Chain Rule of Probability for Intersection of Event

The product rule of intersection as just discussed for two events can be extended to n events.

If $A_1, A_2, A_3, \dots, A_n$ is the set of n events, then the joint probability of these events can be expressed as follows:

$$\begin{aligned} P(A_1 A_2 A_3 \dots A_n) &= P(A_1)P(A_2 / A_1)P(A_3 / A_1 A_2) \dots P(A_n / A_1 A_2 \dots A_{(n-1)}) \\ &= P(A_1) \prod_{i=2}^n P(A_i / A_1 A_2 A_3 \dots A_{(i-1)}) \end{aligned}$$

Mutually Exclusive Events

Two events A and B are said to be mutually exclusive if they do not co-occur. In other words, A and B are mutually exclusive if $P(AB) = 0$. For mutually exclusive events, $P(A \cup B) = P(A) + P(B)$.

In general, the probability of the union of n mutually exclusive events can be written as the sum of their probabilities:

$$P(A_1 \cup A_2 \dots \cup A_n) = P(A_1) + P(A_2) + \dots + P(A_n) = \sum_{i=1}^n P(A_i)$$

Independence of Events

Two events A and B are said to be independent if the probability of their intersection is equal to the product of their individual probabilities; i.e.,

$$P(AB) = P(A)P(B)$$

This is possible because the conditional probability of A given B is the same as the probability of A ; i.e.,

$$P(A/B) = P(A)$$

This means that A is as likely to happen in the set of all the events as it is in the domain of B .

Similarly, $P(B/A) = P(B)$ in order for events A and B to be independent.

When two events are independent, neither of the events is influenced by the fact the other event has happened.

Conditional Independence of Events

Two events A and B are conditionally independent given a third event C if the probability of co-occurrence of A and B given C can be written as follows:

$$P(AB/C) = P(A/C)P(B/C)$$

By the factorization property, $P(AB/C) = P(A/C)P(B/AC)$.

By combining the preceding equations, we see that $P(B/AC) = P(B/C)$ as well.

Do note that the conditional independence of events A and B doesn't guarantee that A and B are independent too. The conditional independence of events property is used a lot in machine-learning areas where the likelihood function is decomposed into simpler form through the conditional independence assumption. Also, a class of network models known as Bayesian networks uses conditional independence as one of several factors to simplify the network.

Bayes Rule

Now that we have a basic understanding of elementary probability, let's discuss a very important theorem called the Bayes rule. We take two events A and B to illustrate the theorem, but it can be generalized for any number of events.

We take $P(AB) = P(A)P(B/A)$ from the product rule of probability. (1)

Similarly, $P(AB) = P(B)P(A/B)$. (2)

Combining (1) and (2), we get

$$P(A)P(B/A) = P(B)P(A/B)$$

$$\Rightarrow P(A/B) = P(A)P(B/A)/P(B)$$

The preceding deduced rule is called the Bayes rule, and it would come handy in many areas of machine learning, such as in computing posterior distribution from likelihood, using Markov chain models, maximizing a posterior algorithm, and so forth.

Probability Mass Function

The probability mass function (pmf) of a random variable is a function that gives the probability of each discrete value that the random variable can take up. The sum of the probabilities must add up to 1.

For instance, in a throw of a fair dice, let the number on the dice face be the random variable X .

Then, the pmf can be defined as follows:

$$P(X=i) = \frac{1}{6} \quad i \in \{1,2,3,4,5,6\}$$

Probability Density Function

The probability density function (pdf) gives the probability density of a continuous random variable at each value in its domain. Since it's a continuous variable, the integral of the probability density function over its domain must be equal to 1.

Let X be a random variable with domain D . $P(x)$ denotes it's a probability density function, so that

$$\int_D P(x) dx = 1$$

For example, the probability density function of a continuous random variable that can take up values from 0 to 1 is given by $P(x) = 2x$ $x \in [0,1]$. Let's validate whether it's a probability density function.

For $P(x)$ to be a probability density function, $\int_{x=0}^1 P(x) dx$ should be 1.

$$\int_{x=0}^1 P(x) dx = \int_{x=0}^1 2x dx = [x^2]_0^1 = 1. \text{ Hence, } P(x) \text{ is a probability density function.}$$

One thing to be noted is that the integral computes the area under the curve, and since $P(x)$ is a probability density function (pdf), the area under the curve for a probability curve should be equal to 1.

Expectation of a Random Variable

Expectation of a random variable is nothing but the mean of the random variable. Let's say the random variable X takes n discrete values, x_1, x_2, \dots, x_n , with probabilities p_1, p_2, \dots, p_n . In other words, X is a discrete random variable with pmf $P(X = x_i) = p_i$. Then, the expectation of the random variable X is given by

$$E[X] = x_1 p_1 + x_2 p_2 + \dots + x_n p_n = \sum_{i=1}^n x_i p_i$$

If X is a continuous random variable with a probability density function of $P(x)$, the expectation of X is given by

$$E[X] = \int_D x P(x) dx$$

where D is the domain of $P(x)$.

Variance of a Random Variable

Variance of a random variable measures the variability in the random variable. It is the mean (expectation) of the squared deviations of the random variable from its mean (or expectation).

Let X be a random variable with mean $\mu = E[X]$

$$\text{Var}[X] = E[(X - \mu)^2] \text{ where } \mu = E[X]$$

If X is a discrete random variable that takes n discrete values with a pmf given by $P(X = x_i) = p_i$, the variance of X can be expressed as

$$\begin{aligned} \text{Var}[X] &= E[(X - \mu)^2] \\ &= \sum_{i=1}^n (x_i - \mu)^2 p_i \end{aligned}$$

If X is a continuous random variable having a probability density function of $P(x)$, then $\text{Var}[X]$ can be expressed as

$$\text{Var}[X] = \int_D (x - \mu)^2 P(x) dx$$

where D is the domain of $P(x)$.

Skewness and Kurtosis

Skewness and Kurtosis are higher-order moment statistics for a random variable. Skewness measures the symmetry in a probability distribution, whereas Kurtosis measures whether the tails of the probability distribution are heavy or not. Skewness is a third-order moment and is expressed as

$$\text{Skew}(X) = \frac{E[(X - \mu)^3]}{(\text{Var}[X])^{3/2}}$$

A perfectly symmetrical probability distribution has a skewness of 0, as shown in the Figure 1-19. A positive value of skewness means that the bulk of the data is toward the left, as illustrated in Figure 1-20, while a negative value of skewness means the bulk of the data is toward the right, as illustrated in Figure 1-21.

Kurtosis is a fourth-order statistic, and for a random variable X with a mean of μ , it can be expressed as

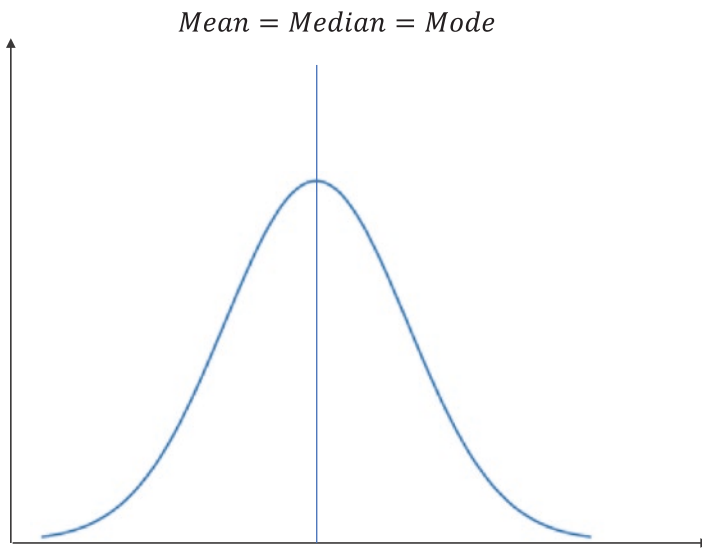

Symmetrical Probability Distribution

Figure 1-19. Symmetric probability distribution

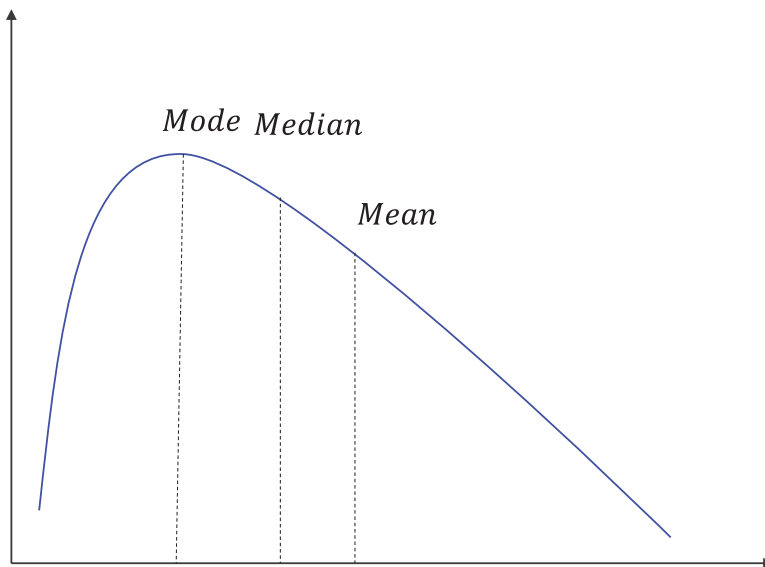

Positive Skewness

Figure 1-20. Probability distribution with positive skewness

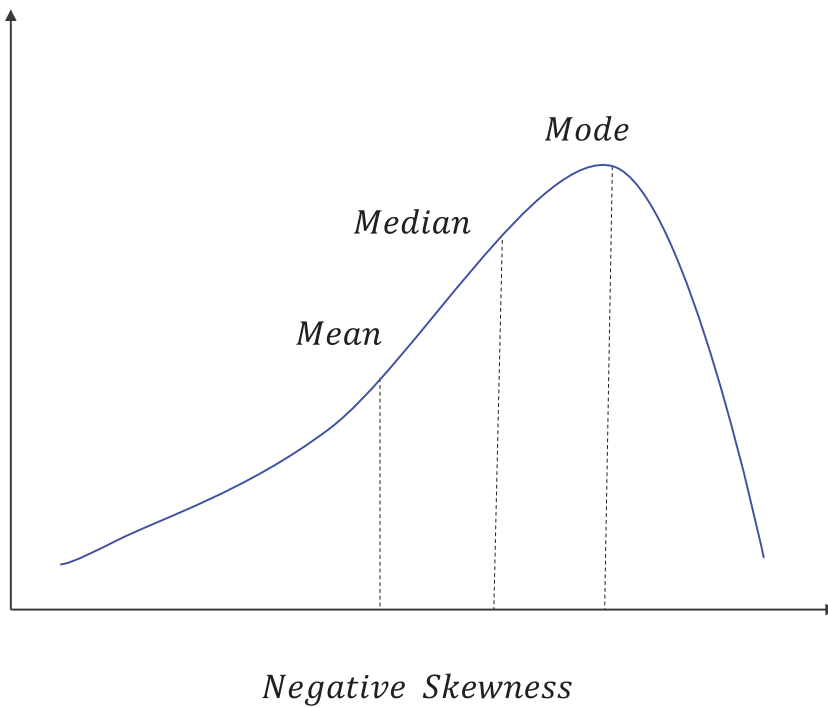

Figure 1-21. Probability distribution with negative skewness

$$Kurt(X) = E\left[\left[X - \mu\right]^4\right] / (\text{Var}[X])^2$$

Higher Kurtosis leads to heavier tails for a probability distribution, as we can see in Figure 1-23. The Kurtosis for a normal distribution (see Figure 1-22) is 3. However, to measure the Kurtosis of other distributions in terms of a Normal distribution, one generally refers to excess Kurtosis, which is the actual Kurtosis minus the Kurtosis for a normal distribution—i.e., 3.

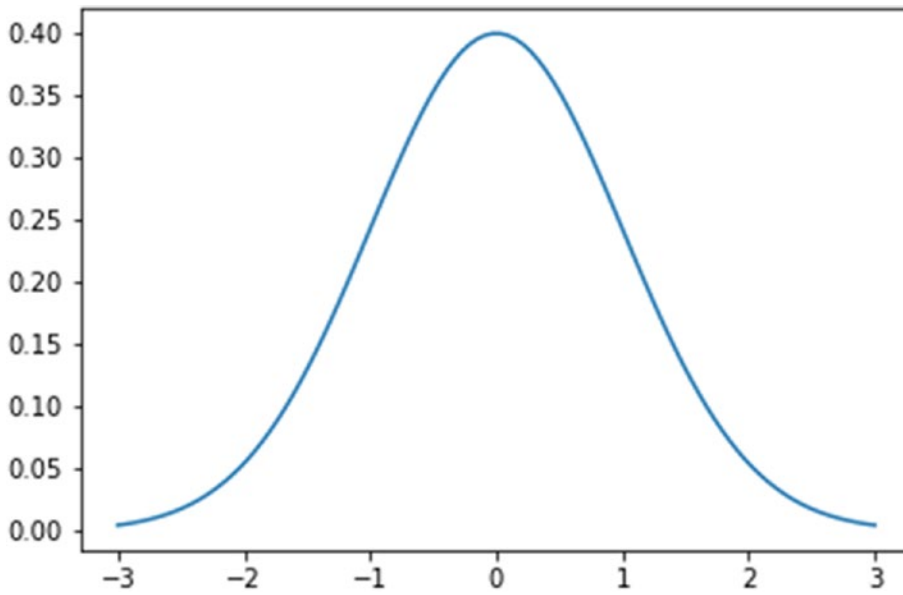

Figure 1-22. Standard normal distribution with Kurtosis = 3

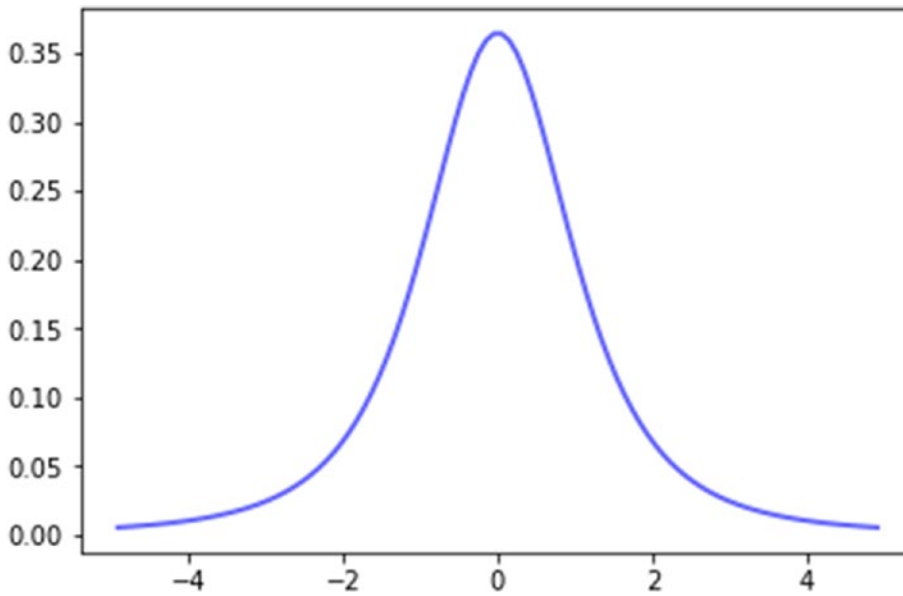

Figure 1-23. Student's T distribution with Kurtosis = ∞

Covariance

The covariance between two random variables X and Y is a measure of their joint variability. The covariance is positive if higher values of X correspond to higher values of Y and lower values of X correspond to lower values of Y . On the other hand, if higher values of X correspond to lower values of Y and lower values of X correspond to higher values of Y then the covariance is negative.

The formula for covariance of X and Y is as follows:

$$cov(X, Y) = E[X - u_x][Y - u_y] \text{ where } u_x = E[X], u_y = E[Y]$$

On simplification of the preceding formula, an alternate is as follows:

$$cov(X, Y) = E[XY] - u_x u_y$$

If two variables are independent, their covariance is zero since $E[XY] = E[X]E[Y] = u_x u_y$

Correlation Coefficient

The covariance in general does not provide much information about the degree of association between two variables, because the two variables maybe on very different scales. Getting a measure of the linear dependence between two variables' correlation coefficients, which is a normalized version of covariance, is much more useful.

The correlation coefficient between two variables X and Y is expressed as

$$\rho = \frac{cov(X, Y)}{\sigma_x \sigma_y}$$

where σ_x and σ_y are the standard deviation of X and Y respectively. The value of ρ lies between -1 and $+1$.

Figure 1-24 illustrates both positive and negative correlations between two variables X and Y .

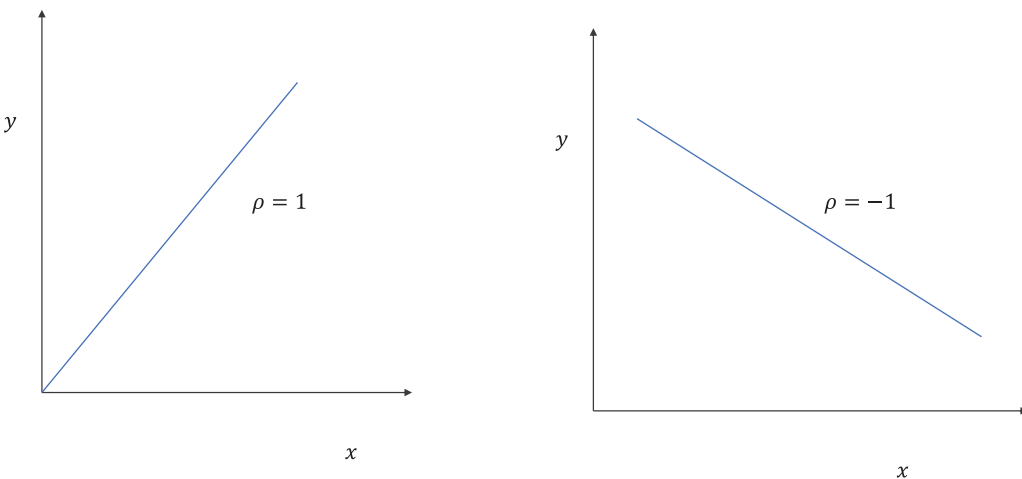

Figure 1-24. Plot of variables with correlation coefficients of +1 and -1

Some Common Probability Distribution

In this section, we will go through some of the common probability distributions that are frequently used in the machine-learning and deep-learning domains.

Uniform Distribution

The probability density function for a uniform distribution is constant. For a continuous random variable that takes up values between a and b ($b > a$), the probability density function is expressed as

$$P(X = x) = f(x) = \begin{cases} 1/(b-a) & \text{for } x \in [a, b] \\ 0 & \text{elsewhere} \end{cases}$$

Illustrated in Figure 1-25 is the probability density curve for a uniform distribution. The different statistics for a uniform distribution are outlined here:

$$E[X] = \frac{(b+a)}{2}$$

$$\text{Median}[X] = \frac{(b+a)}{2}$$

$$\text{Mode}[X] = \text{All points in the interval } a \text{ to } b$$

$$\text{Var}[X] = (b-a)^2 / 12$$

$$\text{Skew}[X] = 0$$

$$\text{Excessive Kurt}[X] = -6/5$$

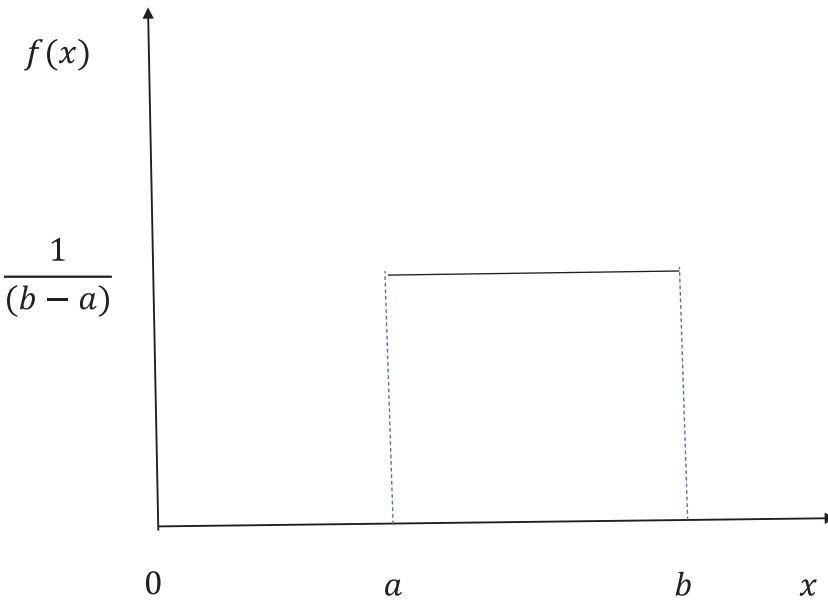

Figure 1-25. Uniform probability distribution

Please note that the excess Kurtosis is the actual Kurtosis minus 3, 3 being the actual Kurtosis for a normal distribution. Hence, the excess Kurtosis is the relative Kurtosis with respect to a normal distribution.

Normal Distribution

This is probably the most important scenario for probability distribution in the real-world. In a normal distribution, the maximum probability density is at the mean of the distribution, and the density falls symmetrically and exponentially to the square of the distance from the mean. The probability density function of a normal distribution can be expressed as

$$P(X = x) = \frac{1}{\sqrt{2\pi} \sigma} e^{-\frac{(x-\mu)^2}{2\sigma^2}} \quad -\infty < x < +\infty$$

where μ is the mean and σ^2 is the variance of the random variable X . Illustrated in Figure 1-26 is the probability density function of a univariate normal distribution.

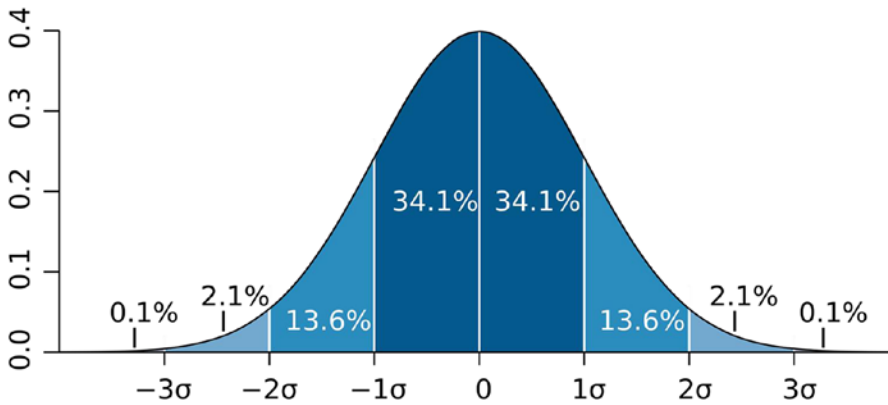

Figure 1-26. Normal probability distribution

As shown in Figure 1-26, 68.2 percent of the data in a normal distribution falls within one standard deviation ($+1/-1\sigma$) of the mean, and around 95.4 percent of the data is expected to fall within $+2/-2\sigma$ of the mean. The important statistics for a normal distribution are outlined here:

$$E[X] = \mu$$

$$\text{Median}[X] = \mu$$

$$\text{Mode}[X] = \mu$$

$$\text{Var}[X] = \sigma^2$$

$$\text{Skew}[X] = 0$$

$$\text{Excess Kurt}[X] = 0$$

Any normal distribution can be transformed into a standard normal distribution by using the following transformation:

$$z = \frac{(x - \mu)}{\sigma}$$

The mean and standard deviation for the standard normal random variable z are 0 and 1 respectively. The standard normal distribution is used a lot in statistical inference tests. Similarly, in linear regression the errors are assumed to be normally distributed.

Multivariate Normal Distribution

A multivariate normal distribution, or Gaussian distribution in n variables denoted by vector $x \in \mathbb{R}^{n \times 1}$, is the joint probability distribution of the associated variables parameterized by the mean vector $\mu \in \mathbb{R}^{n \times 1}$ and covariance matrix $\Sigma \in \mathbb{R}^{n \times n}$.

The probability density function (pdf) of a multivariate normal distribution is as follows:

$$P(x / \mu; \Sigma) = \frac{1}{(2\pi)^{n/2} |\Sigma|^{1/2}} e^{-\frac{1}{2}(x-\mu)^T \Sigma^{-1} (x-\mu)}$$

where $x = [x_1, x_2, \dots, x_n]^T$

$$-\infty < x_i < +\infty \quad \forall i \in \{1, 2, 3, \dots, n\}$$

Illustrated in Figure 1-27 is the probability density function of a multivariate normal distribution. A multivariate normal distribution, or Gaussian distribution, has several applications in machine learning. For instance, for multivariate input data that has correlation, the input features are often assumed to follow multivariate normal distribution, and based on the probability density function, points with low probability density are tagged as anomalies. Also, multivariate normal distributions are widely used in a mixture of Gaussian models wherein a data point with multiple features is assumed to belong to several multivariate normal distributions with different probabilities. Mixtures of Gaussians are used in several areas, such as clustering, anomaly detection, hidden Markov models, and so on.

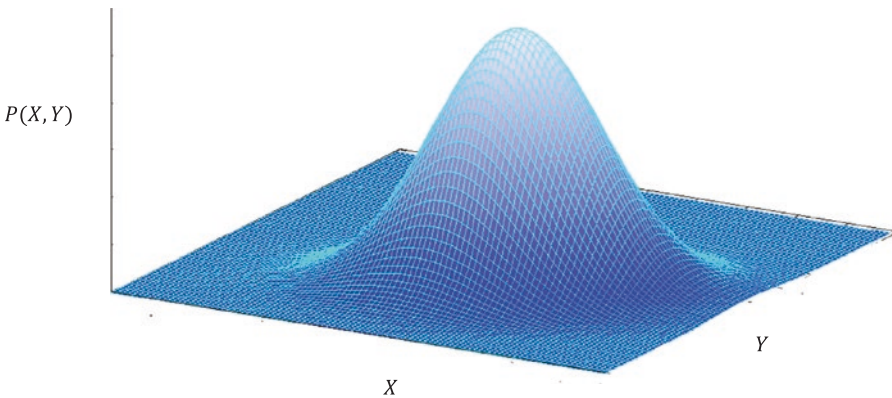

Figure 1-27. Multivariate normal distribution in two variables

Bernoulli Distribution

An experiment in which the two outcomes are mutually exclusive and exhaustive (the sum of probability of the two outcomes is 1) is called a Bernoulli trial.

A Bernoulli trial follows a Bernoulli distribution. Let's say in a Bernoulli trial the two outcomes are success and failure. If the probability of success is p then, since these two events exhaust the sample space, the probability of failure is $1 - p$. Let $x=1$ denote success. Thus, the probability of success or failure can be denoted as follows:

$$P(X = x) = f(x) = p^x (1-p)^{(1-x)} \quad x \in \{0,1\}$$

The preceding expression for $P(X = x)$ denotes the probability mass function of a Bernoulli distribution. The expectation and variance of the probability mass function are as follows:

$$E[X] = p$$

$$\text{Var}[X] = p(1-p)$$

The Bernoulli distribution can be extended to multiclass events that are mutually exclusive and exhaustive. Any two-class classification problem can be modeled as a Bernoulli trial. For instance, the logistic regression likelihood function is based on a Bernoulli distribution for each training data point, with the probability p being given by the sigmoid function.

Binomial Distribution

In a sequence of Bernoulli trials, we are often interested in the probability of the total number of successes and failures instead of the actual sequence in which they occur. If in a sequence of n successive Bernoulli trials x denotes the number of successes, then the probability of x successes out of n Bernoulli trials can be expressed by a probability mass function denoted by

$$P(X = x) = \binom{n}{x} p^x (1-p)^{(n-x)} \quad x \in \{0,1,2,\dots,n\}$$

where p is the probability of success.

The expectation and variance of the distribution are as follows:

$$E[X] = np$$

$$\text{Var}[X] = np(1-p)$$

Illustrated in Figure 1-28 is the probability mass function of a binomial distribution with $n=4$ and $p=0.3$.

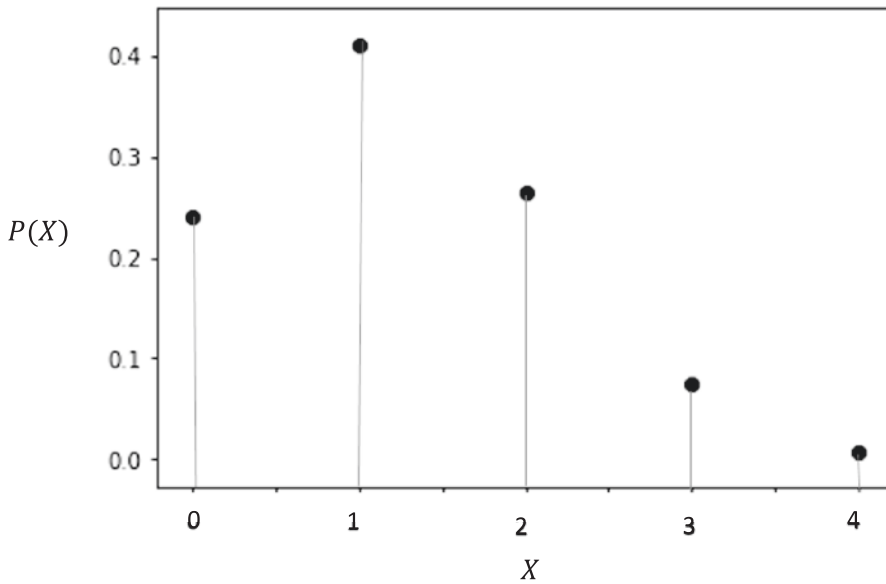

Figure 1-28. Probability Mass function of a Binomial Distribution with $n=4$ and $p = 0.3$

Poisson Distribution

Whenever the rate of some quantity is of concern, like the number of defects in a 1000-product lot, the number of alpha particles emitted by a radioactive substance in the previous four-hour duration, and so on, Poisson distribution is generally the best way to represent such phenomenon. The probability mass function for Poisson distribution is as follows:

$$P(X = x) = \frac{e^{-\lambda} \lambda^x}{x!} \text{ where } x \in \{0, 1, 2, \dots, \infty\}$$

$$E[X] = \lambda$$

$$Var[X] = \lambda$$

Illustrated in Figure 1-29 is the probability mass function of a Poisson distribution with mean of $\lambda = 15$.

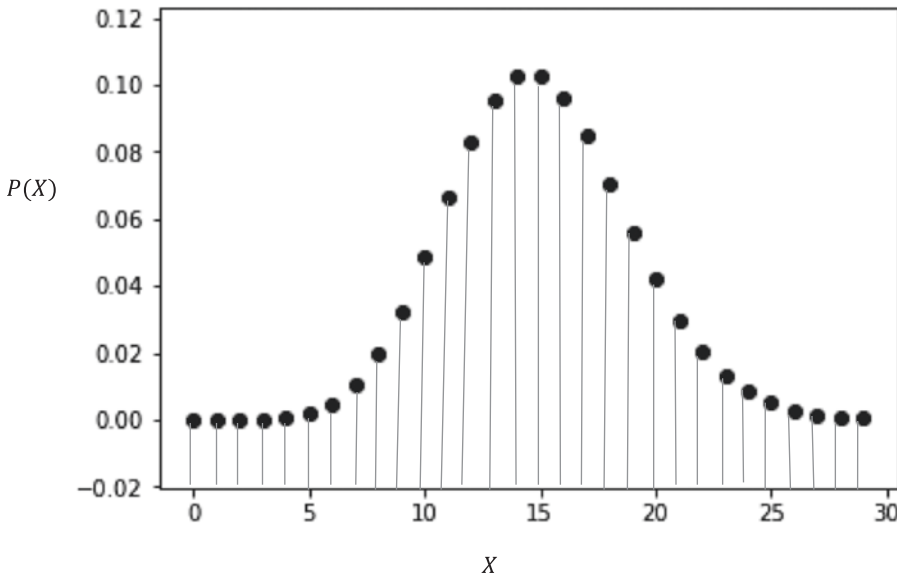

Figure 1-29. Probability mass function of a Poisson distribution with mean = 15

Likelihood Function

Likelihood is the probability of the observed data given the parameters that generate the underlying data. Let's suppose we observe n observations x_1, x_2, \dots, x_n and assume that the observations are independent and identically normally distributed with mean μ and variance σ^2 .

The likelihood function in this case would be as follows:

$$P(\text{Data} / \text{Model parameters}) = P(x_1, x_2, \dots, x_n / \mu, \sigma^2)$$

Since the observations are independent, we can factorize the likelihood as follows:

$$P(\text{Data} / \text{Model parameters}) = \prod_{i=1}^n P(x_i / \mu, \sigma^2)$$

Each of the $x_i \sim \text{Normal}(\mu, \sigma^2)$, hence the likelihood can be further expanded as follows:

$$P(\text{Data} / \text{Model parameters}) = \prod_{i=1}^n \frac{1}{\sqrt{2\pi\sigma}} e^{-\frac{(x_i - \mu)^2}{2\sigma^2}}$$

Maximum Likelihood Estimate

Maximum likelihood estimate (MLE) is a technique for estimating the parameters of a distribution or model. This is achieved by deriving the parameters that would maximize the likelihood function—i.e., maximize the probability of observing the data given the parameters of the model. Let's work through an example to understand maximum likelihood estimates.

Suppose Adam tosses a coin 10 times and observes 7 heads and 3 tails. Also, assume that the tosses are independent and identical. What would be the maximum likelihood estimate for the probability of heads for the given coin?

Each toss of a coin is a Bernoulli trial, with the probability of heads being, let's say, p , which is an unknown parameter that we want to estimate. Also, let the event that a toss produces heads be denoted by 1 and tails by 0.

The likelihood function can be represented as follows:

$$\begin{aligned} P(\text{Data} / \text{parameter}) &= L(p) = P(x_1, x_2, \dots, x_{10} / p) \\ &= \prod_{i=1}^{10} P(x_i / p) \\ &= p^7 (1-p)^3 \end{aligned}$$

Just for clarification, let's see how the likelihood L came to be $p^7(1-p)^3$.

For each heads, the probability from the Bernoulli distribution is $P(x_i = 1 / p) = p^1 (1-p)^0 = p$. Similarly, for each tails the probability is $P(x_i = 0 / p) = p^0 (1-p)^1 = 1-p$. As we have 7 heads and 3 tails, we get the likelihood $L(p)$ to be $p^7(1-p)^3$.

To maximize the likelihood L , we need to take the derivative of L with respect to p and set it to 0.

Now, instead of maximizing the likelihood $L(p)$ we can maximize the logarithm of the likelihood—i.e., $\log L(p)$. Since logarithmic is a monotonically increasing function, the parameter value that maximizes $L(p)$ would also maximize $\log L(p)$. Taking the derivative of the log of the likelihood is mathematically more convenient than taking the derivative of the product form of the original likelihood.

$$\log L(p) = 7 \log p + 3 \log(1-p)$$

Taking the derivative of both sides and setting it to zero looks as follows:

$$\begin{aligned} \frac{d \log(L(p))}{dp} &= \frac{7}{p} - \frac{3}{1-p} = 0 \\ \Rightarrow p &= 7/10 \end{aligned}$$

Interested readers can compute the second derivative $\frac{d^2 \log(L)}{dp^2}$ at $p = \frac{7}{10}$; you will for sure get a negative value, confirming that $p = \frac{7}{10}$ is indeed the point of maxima.

Some of you would have already had $\frac{7}{10}$ in mind without even going through maximum likelihood, just

by the basic definition of probability. As you will see later, with this simple method a lot of complex model parameters are estimated in the machine-learning and deep-learning world.

Let's look at another little trick that might come in handy while working on optimization. Computing the maxima of a function $f(x)$ is the same as computing the minima for the function $-f(x)$. The maxima for $f(x)$ and the minima for $-f(x)$ would take place at the same value of x . Similarly, the maxima for $f(x)$ and the minima for $1/f(x)$ would happen at the same value of x .

Often in machine-learning and deep-learning applications we use advanced optimization packages, which only know to minimize a cost function in order to compute the model parameters. In such cases, we conveniently convert the maximization problem to a minimization problem by either changing the sign or taking the reciprocal of the function, whichever makes more sense. For example, in the preceding problem we could have taken the negative of the log likelihood function—i.e., $\text{LogL}(p)$ —and minimized it; we would have gotten the same probability estimate of 0.7.

Hypothesis Testing and p Value

Often, we need to do some hypothesis testing based on samples collected from a population. We start with a null hypothesis and, based on the statistical test performed, accept the null hypothesis or reject it.

Before we start with hypothesis testing, let's first consider one of the core fundamentals in statistics, which is the Central Limit theorem.

Let $x_1, x_2, x_3, \dots, x_n$ be the n independent and identically distributed observation of a sample from a population with mean μ and finite variance σ^2 .

The sample mean denoted by \bar{x} follows normal distribution, with mean μ and variance $\frac{\sigma^2}{n}$; i.e.,

$$\bar{x} \sim \text{Normal}\left(\mu, \frac{\sigma^2}{n}\right) \text{ where } \bar{x} = \frac{x_1 + x_2 + x_3 + \dots + x_n}{n}$$

This is called the Central Limit theorem. As the sample size n increases, the variance of \bar{x} reduces and tends toward zero as $n \rightarrow \infty$.

Figure 1-30 illustrates a population distribution and a distribution of the mean of samples of fixed size n drawn from the population.

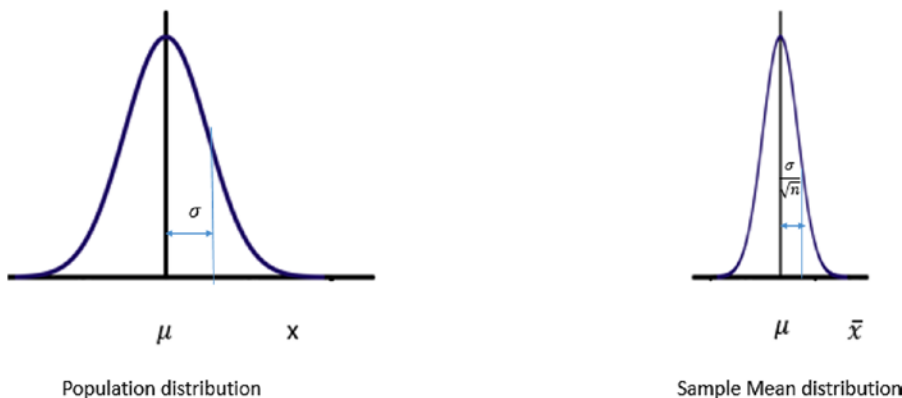

Figure 1-30. Distribution for population and distribution for sample mean

Please note that the sample mean follows normal distribution irrespective of whether the population variable is normally distributed or not. Now, let's consider a simple hypothesis-testing problem.

Boys who are 10 years old are known to have a mean weight of 85 pounds, with a standard deviation of 11.6. Boys in one county are checked as to whether they are obese. To test this, the mean weight of a group of 25 random boys from the county is collected. The mean weight is found to be 89.16 pounds.

We would have to form a null hypothesis, and would reject it through the test if the evidence against the null hypothesis were strong enough.

Let us consider the null hypothesis: H_0 . The children in the county are not obese; i.e., they come from the same population with a mean of $\mu = 85$.

Under the null hypothesis H_0 , the sample mean is as follows:

$$\bar{x} \sim Normal\left(85, \frac{11.6^2}{25}\right)$$

The closer the sample mean observed is to the population mean, the better it is for the null hypothesis to be true. On the other hand, the further the sample mean observed is away from the population mean, the stronger the evidence is against the null hypothesis.

The standard normal variate $z = (\bar{x} - \mu) / (\sigma / \sqrt{n}) = (89.16 - 85) / (11.6 / \sqrt{25}) = +1.75$

For every hypothesis test, we determine a p value. The p value of this hypothesis test is the probability of observing a sample mean that is further away from what is observed; i.e., $P(\bar{x} \geq 89.16)$ or $P(z \geq 1.75)$. So, the smaller the p value is, the stronger the evidence is against the null hypothesis.

When the p value is less than a specified threshold percentage α , which is called the type-1 error, the null hypothesis is rejected.

Please note that the deviation of the sample mean from the population can be purely the result of randomness since the sample mean has finite variance σ^2/n . The α gives us a threshold beyond which we should reject the null hypothesis even when the null hypothesis is true. We might be wrong, and the huge deviation might just be because of randomness. But the probability of that happening is very small, especially if we have a large sample size, since the sample mean standard deviation reduces significantly. When we do reject the null hypothesis even if the null hypothesis is true, we commit a type-I error, and hence α gives us the probability of a type-1 error.

The p value for this test is $P(Z \geq 1.75) = 0.04$

The type-I error α that one should choose depends on one's knowledge of the specific domain in which the test is performed. Generally, $\alpha = 0.05$ is a good enough type-1 error setting. Since the p value computed is less than the type-I error specified for the test, we cannot accept the null hypothesis. We say the test is statistically significant. The p value has been illustrated in Figure 1-31.

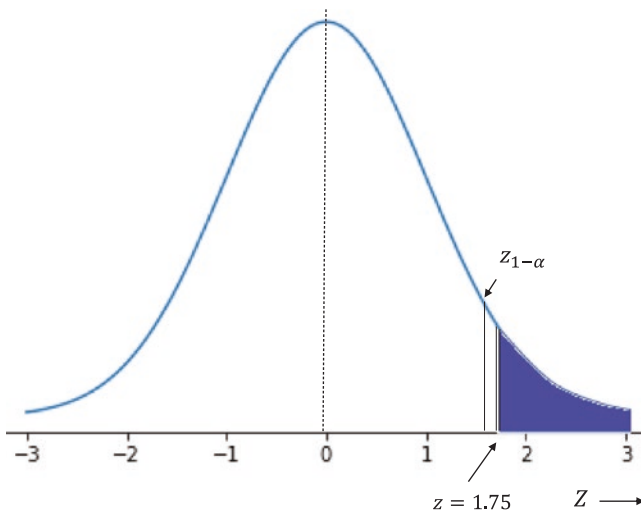

Figure 1-31. Z test showing *p* value

The dark-colored area corresponds to the *p* value; i.e., $P(z \geq 1.75)$. $Z_{1-\alpha}$ corresponds to the *z* value beyond which we are likely to commit a Type-1 error given the null hypothesis is true. The area beyond $z_{1-\alpha}$ —i.e., $P(z \geq Z_{1-\alpha})$ —stands for the Type-1 error probability. Since the *p* value is less than the Type-1 error probability for the test, the null hypothesis can't be taken as true. A Z test such as this is generally followed up by another good practice—the Confidence Interval test.

Also, the preceding test, popularly known as the Z test, is not always possible unless we have the population variance provided to us. For certain problems, we might not have the population variance. In such cases, the Student-T test is more convenient since it uses sample variances instead of population variances.

The reader is encouraged to explore more regarding these statistical tests.

Formulation of Machine-Learning Algorithm and Optimization Techniques

The aim of modeling is to minimize the cost function of the model parameters given the data by using different optimization techniques. One may ask that if we set the derivative or gradient of the cost function to zero would we have the model parameters. This is not always possible, since all solutions might not have a closed-form solution, or the closed-form solution might be computationally expensive or intractable. Further, when the data size is huge there would be memory constraints when going for a closed-form solution. Hence, iterative methods are generally used for complex optimization problems.

Machine learning can be broadly classified into two types:

- Supervised machine learning
- Unsupervised machine learning

Supervised Learning

In supervised learning, each training data point is associated with several input features—typically an input feature vector and its corresponding label. A model is constructed with several parameters that try to predict the output label given the input feature vector. The model parameters are derived by optimizing some form of cost function that is based on the error of prediction; i.e., the discrepancy between the actual labels and the predicted labels for the training data points. Alternatively, maximizing the likelihood of the training data would also provide us with the model parameters.

Linear Regression as a Supervised Learning Method

We might have a dataset that has the prices for houses as the target variable or output label, whereas features like area of the house, number of bedrooms, number of bathrooms, and so forth are its input feature vector. We can define a function that would predict the price of the house based on the input feature vector.

Let the input feature vector be represented by x' and the predicted value be y_p . Let the actual value of the housing price—i.e., the output label—be denoted by y . We can define a model where the output label is expressed as a function of the input feature vector, as shown in the following equation. The model is parameterized by several constants that we wish to learn via the training process.

$$y / x' = \theta'^T x' + b + \epsilon$$

where ϵ is the random variation in prediction and $\epsilon \sim \text{Normal}(0, \sigma^2)$.

So, the housing price given an input (y / x') is a linear combination of the input vector x' plus a bias term b and a random component ϵ , which follows a normal distribution with a 0 mean and a finite variance of σ^2 .

As ϵ is a random component, it can't be predicted, and the best we can predict is the mean of housing prices given a feature value i.e.

$$\text{The predicted value } y_p / x' = E[y / x'] = \theta'^T x' + b$$

Here, θ' is the linear combiner and b is the bias or the intercept. Both θ' and b are the model parameters that we wish to learn. We can express $y_p = \theta'^T x$, where the bias has been added to the model parameter corresponding to the constant feature 1. This small trick makes the representation simpler.

Let's say we have m samples $(x^{(1)}, y^{(1)})$, $(x^{(2)}, y^{(2)})$, ..., $(x^{(m)}, y^{(m)})$. We can compute a cost function that takes the sum of the squares of the difference between the predicted and the actual values of the housing prices and try to minimize it in order to derive the model parameters.

The cost function can be defined as

$$C(\theta) = \sum_{i=1}^m (\theta'^T x_i - y^{(i)})^2$$

We can minimize the cost function with respect to θ to determine the model parameter. This is a linear regression problem where the output label or target is continuous. Regression falls under the supervised class of learning. Figure 1-32 illustrates the relationship between housing prices and number of bedrooms.

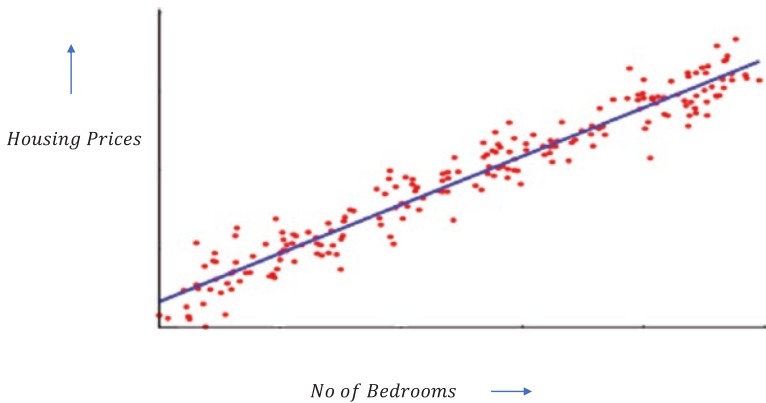

Figure 1-32. Regression fit to the Housing Prices versus Number of Bedrooms data. The red points denote the data points, and the blue line indicates the fitted regression line.

Let the input vector be $x' = [x_1 \ x_2 \ x_3]^T$, where

$x_1 \rightarrow$ the area of the house

$x_2 \rightarrow$ the number of bedrooms

$x_3 \rightarrow$ the number of bathrooms

Let the parameter vector corresponding to the input feature vector be $\theta' = [\theta_1 \ \theta_2 \ \theta_3]^T$, where

$\theta_1 \rightarrow$ additional Cost per unit area

$\theta_2 \rightarrow$ additional cost per bedroom

$\theta_3 \rightarrow$ additional cost per bathroom

After taking into consideration the bias term, the input feature vector becomes $x = [x_0 \ x_1 \ x_2 \ x_3]^T$, where

$x_0 \rightarrow$ constant value of 1, i.e., feature corresponding to the bias term

$x_1 \rightarrow$ the area of the house

$x_2 \rightarrow$ the number of bedrooms

$x_3 \rightarrow$ the number of bathrooms

and $\theta = [\theta_0 \theta_1 \theta_2 \theta_3]$, where

$\theta_0 \rightarrow$ bias term or intercept

$\theta_1 \rightarrow$ additional cost per unit area

$\theta_2 \rightarrow$ additional cost per bedroom

$\theta_3 \rightarrow$ additional cost per bathroom

Now that we have some understanding of how to construct a regression problem and its associated cost function, let's simplify the problem and proceed toward deriving the model parameters.

$$\text{Model parameter } \theta^* = \underbrace{\text{Arg Min}}_{\theta} C(\theta) = \underbrace{\text{Arg Min}}_{\theta} \sum_{i=1}^m (\theta^T x_i - y^{(i)})^2$$

The input vectors for all the samples can be combined to a matrix X , and the corresponding target output can be represented as a vector Y .

$$X = \begin{bmatrix} x_0^{(1)} & x_1^{(1)} & x_2^{(1)} & x_3^{(1)} \\ x_0^{(2)} & x_1^{(2)} & x_2^{(2)} & x_3^{(2)} \\ x_0^{(3)} & x_1^{(3)} & x_2^{(3)} & x_3^{(3)} \\ & & \cdot & \\ & & \cdot & \\ x_0^{(m)} & x_1^{(m)} & x_2^{(m)} & x_3^{(m)} \end{bmatrix} \quad Y = \begin{bmatrix} y^{(1)} \\ y^{(2)} \\ y^{(3)} \\ \cdot \\ \cdot \\ y^{(m)} \end{bmatrix}$$

If we represent the vector of predictions as Yp , then $Yp = X\theta$. So, the error in prediction vector e can be represented as follows:

$$e = X\theta - Y$$

Hence, $C(\theta)$ can be expressed as the square of the l^2 norm of the error vector e , i.e.,

$$\begin{aligned} C(\theta) &= \|e\|_2^2 \\ &= \|X\theta - Y\|_2^2 \\ &= (X\theta - Y)^T (X\theta - Y) \end{aligned}$$

Now that we have a simplified cost function in matrix form, it will be easy to apply different optimization techniques. These techniques would work for most cost functions, be it a convex cost function or a non-convex one. For non-convex ones, there are some additional things that need to be considered, which we will discuss in detail while considering neural networks.

We can directly derive the model parameters by computing the gradient and setting it to zero vector. You can apply the rules that we learned earlier to check if the conditions of minima are satisfied.

The gradient of the cost function with respect to the parameter vector θ is as seen here:

$$\nabla C(\theta) = 2X^T(X\theta - Y)$$

Setting $\nabla C(\theta) = 0$, we get $X^T X\theta = X^T Y \Rightarrow \hat{\theta} = (X^T X)^{-1} X^T Y$.

If one looks at this solution closely one can observe that the pseudo-inverse of X —i.e., $(X^T X)^{-1} X^T$ —comes into the solution of the linear regression problem. This is because a linear regression parameter vector can be looked at as a solution to the equation $X\theta = Y$, where X is an $m \times n$ rectangular matrix with $m > n$.

The preceding expression for $\hat{\theta}$ is the closed-form solution for the model parameter. Using this derived $\hat{\theta}$ for new data point x_{new} , we can predict the price of housing as $\hat{\theta}^T x_{new}$.

The computation of the inverse of $(X^T X)$ is both cost and memory intensive for large datasets. Also, there are situations when the matrix $X^T X$ is singular and hence its inverse is not defined. Therefore, we need to look at alternative methods to get to the minima point.

One thing to validate after building a linear regression model is the distribution of residual errors for the training data points. The errors should be approximately normally distributed with a 0 mean and some finite variance. The *QQ* plot that plots the actual quantile values for the error distribution versus the theoretical quantile values for the error distribution can be used to check whether the assumption of Gaussianity for the residual is satisfied.

Linear Regression Through Vector Space Approach

The linear regression problem is to determine the parameter vector θ such that $X\theta$ is as close to the output vector Y as possible. $X \in \mathbb{R}^{m \times n}$ is the data matrix and can be thought of as n column vectors $c_i \in \mathbb{R}^{m \times 1}$ stacked one after the other, as shown here:

$$X = [c_1 \ c_2 \ \dots \ c_n]$$

The dimension of column space is m whereas the number of column vectors is n . Hence, the column vectors at best can span a subspace of dimension n within the m -dimensional vector space. The subspace is depicted in Figure 1-33. Although it looks like a 2-D surface, we need to imagine it as an n -dimensional space. The linear combination of the columns of X with the parameters gives the prediction vector, as shown here:

$$X\theta = \theta_1 c_1 + \theta_2 c_2 + \dots + \theta_n c_n$$

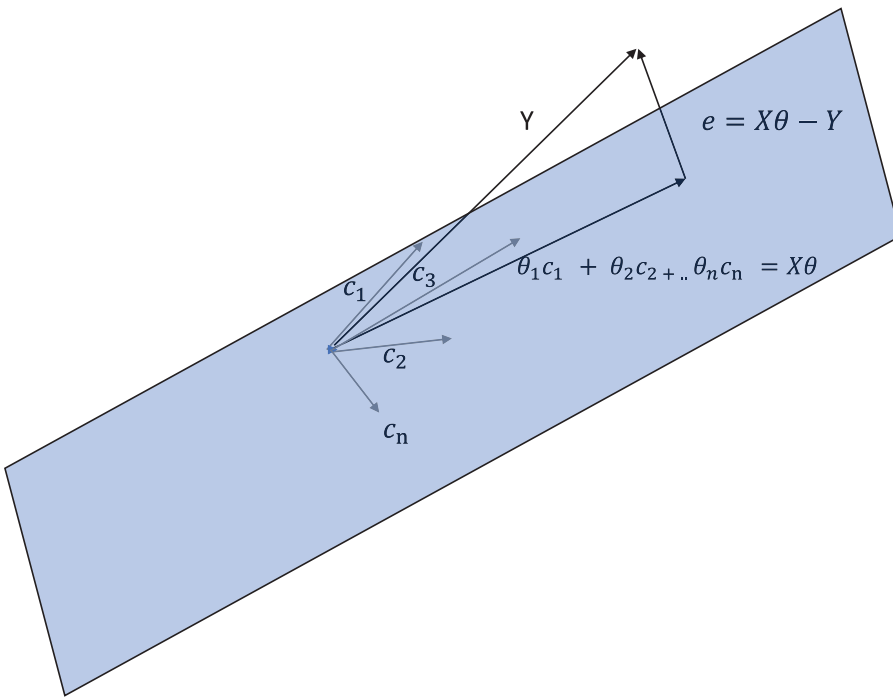

Figure 1-33. Linear regression as a vector space problem

Since $X\theta$ is nothing but the linear combination of the column vectors of X , $X\theta$ stays in the same subspace as the ones spanned by the column vectors $c_i \forall i = \{1, 2, 3 \dots n\}$.

Now the actual target value vector Y lies outside the subspace spanned by the column vectors of X , thus no matter what θ we combine X with, $X\theta$ can never equal or align itself in the direction of Y . There is going to be a non-zero error vector given by $e = Y - X\theta$.

Now that we know that we have an error, we need to investigate how to reduce the L^2 norm of the error. For the L^2 norm of the error vector to be at a minimum it should be perpendicular to the prediction vector $X\theta$. Since $e = Y - X\theta$ is perpendicular to $X\theta$, it should be perpendicular to all vectors in that subspace.

So, the dot product of all the column vectors of X with the error vector $Y - X\theta$ should be zero, which gives us the following:

$$c_1^T [Y - X\theta] = 0, c_2^T [Y - X\theta] = 0, \dots, c_n^T [Y - X\theta] = 0$$

This can be rearranged in a matrix form as follows:

$$\begin{aligned} [c_1 \ c_2 \ \dots \ c_n]^T [Y - X\theta] &= 0 \\ \Rightarrow X^T [Y - X\theta] &= 0 \Rightarrow \hat{\theta} = (X^T X)^{-1} X^T Y \end{aligned}$$

Also, please note that the error vector will be perpendicular to the prediction vector only if $X\theta$ is the projection of Y in the subspace spanned by the column vectors of X . The sole purpose of this illustration is to emphasize the importance of vector spaces in solving machine-learning problems.

Classification

Similarly, we may look at classification problems where instead of predicting the value of a continuous variable we predict the class label associated with an input feature vector. For example, we can try to predict whether a customer is likely to default based on his recent payment history and transaction details as well as his demographic and employment information. In such a problem, we would have data with the features just mentioned as input and a target indicating whether the customer has defaulted as the class label. Based on this labelled data, we can build a classifier that can predict a class label indicating whether the customer will default, or we can provide a probability score that the customer will default. In this scenario, the problem is a binary classification problem with two classes—the defaulter class and the non-defaulter class. When building such a classifier, the least square method might not give a good cost function since we are trying to guess the label and not predict a continuous variable. The popular cost functions for classification problems are generally log-loss cost functions that are based on maximum likelihood and entropy-based cost functions, such as Gini Entropy and Shannon Entropy.

The classifiers that have linear decision boundaries are called linear classifiers. Decision boundaries are hyperplanes or surfaces that separate the different classes. In the case of linear decision boundaries, the separating plane is a hyperplane.

Figures 1-34 and 1-35 illustrate linear and non-linear decision boundaries respectively for the separation of two classes.

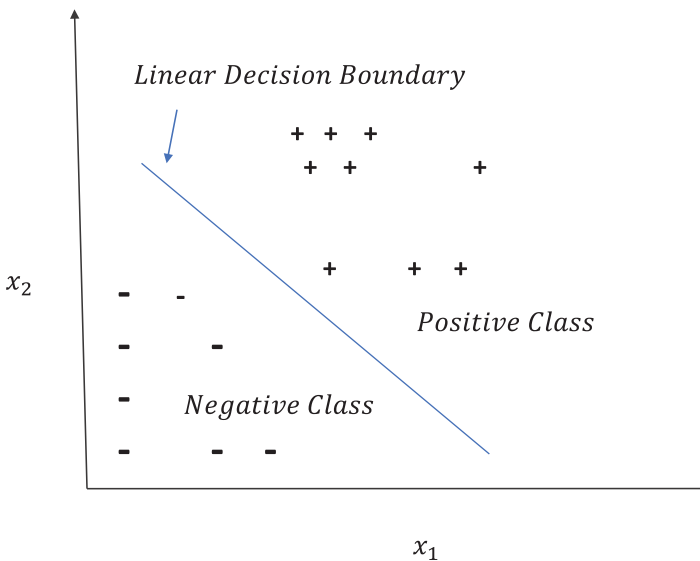

Figure 1-34. Classification by a linear decision boundary

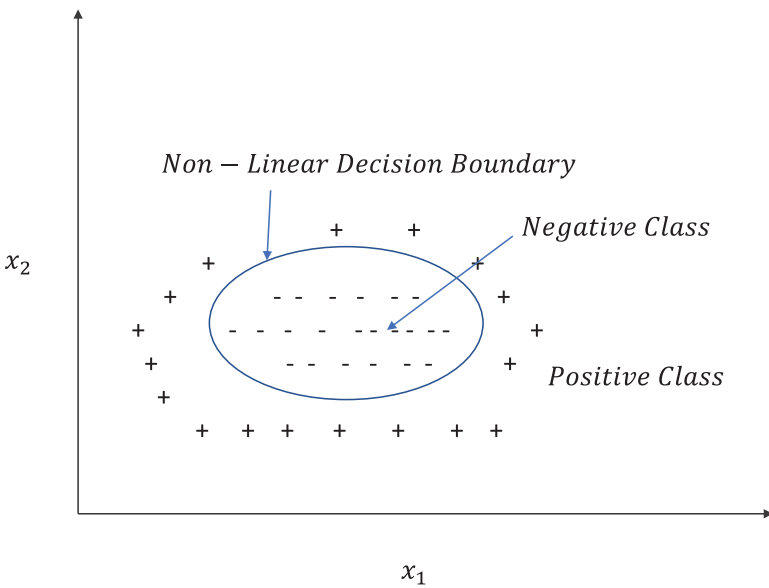

Figure 1-35. Classification by a non-linear decision boundary

I would like to briefly discuss one of the most popular and simple classifiers, logistic regression, so that it becomes clear how the log-loss cost function comes into the picture via maximum likelihood methods in case of classification problems.

Suppose $(x^{(i)}, y^{(i)})$ are the labelled data points, where $x^{(i)} \in \mathbb{R}^{n \times 1} \quad \forall i \in \{1, 2, \dots, m\}$ is the input vector, which includes the constant feature value of 1 as a component, and $y^{(i)}$ determines the class. The value of $y^{(i)}$ is set to 1 when the data point corresponds to a customer who has defaulted on his loan and 0 if the customer has not defaulted. The input vector $x^{(i)}$ can be represented in terms of its components as follows:

$$x^{(i)} = \begin{bmatrix} 1 & x_0^{(1)} & x_1^{(1)} & x_2^{(1)} & x_3^{(1)} \end{bmatrix}$$

Logistic regression in general is a linear classifier and uses a squashing function to convert the linear score into probability. Let $\theta = [\theta_0 \theta_1 \theta_2 \dots \theta_n]$ be the model parameter with each $\theta_j \quad \forall j \in \{0, 1, 2, \dots, n\}$

representing the model parameter component with respect to the j th feature x_j of the input vector x .

The term θ_0 is the bias term. In linear regression, the bias is nothing but the intercept on the output y axis. We will look at what this bias term means for logistic regression (and for other linear classifiers) shortly.

The dot product $\theta^T x$ determines whether the given datapoint is likely to be a positive class or a negative class. For the problem at hand, the positive class is the event the customer defaults on his loan repayment and the negative class is the event that the customer doesn't default. The probability that the customer will default given the input and the model is given by the following:

$$P(y=1/x, \theta) = 1 / (1 + \exp(-\theta^T x)) = p$$

$$P(y=0/x, \theta) = 1 - 1 / (1 + \exp(-\theta^T x)) = \exp(-\theta^T x) / (1 + \exp(-\theta^T x)) = q$$

Now, let's look at the probability values for different values of $\theta^T x$:

- $\theta^T x = 0$ then the probability of positive class is $1/2$.
- When $\theta^T x > 0$ the probability of a positive class is greater than $1/2$ and less than 1.
- When $\theta^T x < 0$ the probability of a positive class is less than $1/2$ and greater than 0.
- When $\theta^T x$ is sufficiently large and positive, i.e., $\theta^T x \rightarrow \infty$, the probability $\rightarrow 1$.
- When $\theta^T x$ is sufficiently large and negative, i.e., $\theta^T x \rightarrow -\infty$, the probability $\rightarrow 0$.

The good thing about this probability formulation is that it keeps the values between 0 and 1, which would not have been possible with linear regression. Also, instead of the actual class, it gives continuous probability. Thus, depending on the problem at hand, the cut-off probability thresholds can be defined to determine the class.

This probability model function is called a logistic or sigmoid function. It has smooth, continuous gradients that make the model training mathematically convenient.

If we look carefully we will see that the customer class y for each training sample follows a Bernoulli distribution, which we discussed earlier. For every data point, the class $y^{(i)} / x^{(i)} \sim \text{Bernoulli}(1, p_i)$. Based on the probability mass function of Bernoulli distribution, we can say the following:

$$P(y^{(i)} / x^{(i)}, \theta) = (1 - p_i)^{1 - y^{(i)}} \quad \text{where } p_i = 1 / (1 + \exp(-\theta^T x))$$

Now, how do we define the cost function? We compute the likelihood of the data given the model parameters and then determine the model parameters that maximize the computed likelihood. We define the likelihood by L , and it can be represented as

$$L = P(\text{Data} / \text{model}) = P(D^{(1)} D^{(2)} \dots D^{(m)} / \theta)$$

where $D^{(i)}$ represents the i th training sample $(x^{(i)}, y^{(i)})$.

Assuming the training samples are independent, given the model, L can be factorized as follows:

$$\begin{aligned} L &= P(D^{(1)} D^{(2)} \dots D^{(m)} / \theta) \\ &= P(D^{(1)} / \theta) P(D^{(2)} / \theta) \dots P(D^{(m)} / \theta) \\ &= \prod_{i=1}^m P(D^{(i)} / \theta) \end{aligned}$$

We can take the log on both sides to convert the product of probabilities into a sum of the log of the probabilities. Also, the optimization remains the same since the maxima point for both L and $\log L$ would be the same, as log is a monotonically increasing function.

Taking log on both sides, we get the following:

$$\log L = \sum_{i=1}^m \log P(D^{(i)} / \theta)$$

Now, $P(D^{(i)} / \theta) = P((x^{(i)}, y^{(i)}) / \theta) = P(x^{(i)} / \theta) P(y^{(i)} / x^{(i)}, \theta)$.

We are not concerned about the probability of the data point—i.e., $P(x^{(i)} / \theta)$ —and assume that all the data points in the training are equally likely for the given model. So, $P(D^{(i)} / \theta) = k P(y^{(i)} / x^{(i)}, \theta)$, where k is a constant.

Taking the log on both sides, we get the following:

$$\log P(D^{(i)} / \theta) = \log k + y^{(i)} \log p_i + (1 - y^{(i)}) \log(1 - p_i)$$

Summing over all data points, we get the following:

$$\log L = \sum_{i=1}^m \log k + y^{(i)} \log p_i + (1 - y^{(i)}) \log(1 - p_i)$$

We need to maximize the $\log L$ to get the model parameter θ . Maximizing $\log L$ is the same as minimizing $-\log L$, and so we can take the $-\log L$ as the cost function for logistic regression and minimize it. Also, we can drop the $\log k$ sum since it's a constant and the model parameter at the minima would be same irrespective of whether we have the $\log k$ sum. If we represent the cost function as $C(\theta)$, it can be expressed as seen here:

$$C(\theta) = \sum_{i=1}^m -y^{(i)} \log p_i - (1 - y^{(i)}) \log(1 - p_i)$$

$$\text{where } p_i = 1 / (1 + \exp(-\theta^T x))$$

$C(\theta)$ is a convex function in θ , and the reader is encouraged to verify it with the rules learned earlier in the “Calculus” section. $C(\theta)$ can be minimized by common optimization techniques.

Hyperplanes and Linear Classifiers

Linear classifiers in some way or another are related to a hyperplane, so it makes sense to look at that relationship. In a way, learning a linear classifier is about learning about the hyperplane that separates the positive class from the negative class.

A hyperplane in an n -dimensional vector space is a plane of dimension $(n - 1)$ that divides the n -dimensional vector space into two regions. One region consists of vectors lying above the hyperplane, and the other region consists of vectors lying below the hyperplane. For a two-dimensional vector space, straight lines act as a hyperplane. Similarly, for a three-dimensional vector space, a two-dimensional plane acts as a hyperplane.

A hyperplane is defined by two major parameters: its perpendicular distance from the origin represented by a bias term b' and the orientation of the hyperplane determined by a unit vector w perpendicular to the hyperplane surface as shown in Figure 1-36.

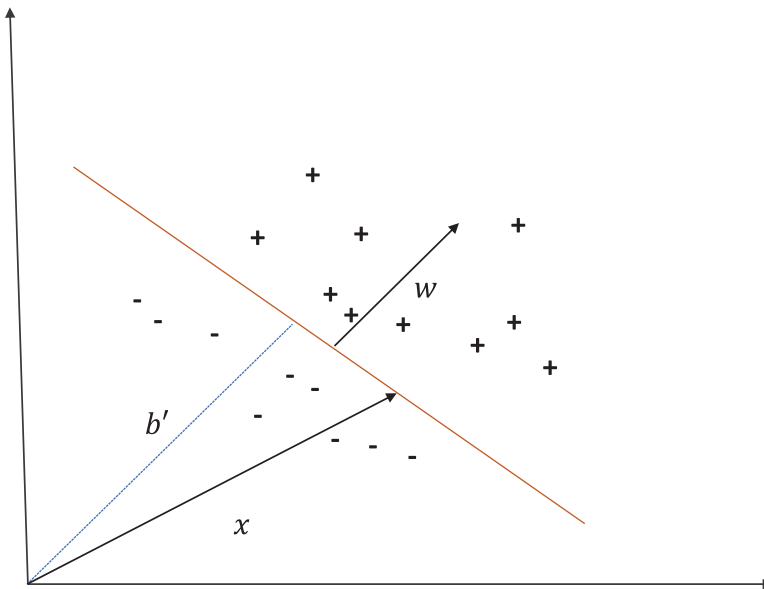

Figure 1-36. Hyperplanes separating the two classes

For a vector $x \in \mathbb{R}^{n-1}$ to lie on the hyperplane, the projection of the vector in the direction of w should equal the distance of the hyperplane from origin—i.e., $w^T x = b'$. Thus, any point lying on the hyperplane must satisfy $w^T x - b' = 0$. Similarly, $w^T x - b' > 0$ must be satisfied for points lying above the hyperplane and $w^T x - b' < 0$ for points lying below the hyperplane.

In linear classifiers, we learn to model the hyperplane, or learn the model parameters w and b . The vector w is generally aligned toward the positive class. The Perceptron and linear SVM are linear classifiers. Of course, the ways SVM and Perceptron learn the hyperplane are totally different, and hence they would come up with different hyperplanes, even for the same training data.

Even if we look at logistic regression, we see that it is based on a linear decision boundary. The linear decision boundary is nothing but a hyperplane, and points lying on the hyperplane (i.e., $w^T x - b' = 0$) are assigned a probability of 0.5 for either of the classes. And again, the way the logistic regression learns the decision boundary is totally different from the way SVM and Perceptron models do.

Unsupervised Learning

Unsupervised machine-learning algorithms aim at finding patterns or internal structures within datasets that contain input data points without labels or targets. K -means clustering, the mixture of Gaussians, and so on are methods of unsupervised learning. Even data-reduction techniques like Principal Component Analysis (PCA), Singular Value Decomposition (SVD), auto-encoders, and so forth are unsupervised learning methods.

Optimization Techniques for Machine Learning

Gradient Descent

Gradient descent, along with its several variants, is probably the most widely used optimization technique in machine learning and deep learning. It's an iterative method that starts with a random model parameter and uses the gradient of the cost function with respect to the model parameter to determine the direction in which the model parameter should be updated.

Suppose we have a cost function $C(\theta)$, where θ represents the model parameters. We know the gradient of the cost function with respect to θ gives us the direction of maximum increase of $C(\theta)$ in a linear sense at the value of θ at which the gradient is evaluated. So, to get the direction of maximum decrease of $C(\theta)$ in a linear sense, one should use the negative of the gradient.

The update rule of the model parameter θ at iteration $(t + 1)$ is given by

$$\theta^{(t+1)} = \theta^{(t)} - \eta \nabla C(\theta^{(t)})$$

where η represents the learning rate and $\theta^{(t+1)}$ and $\theta^{(t)}$ represent the parameter vector at iteration $(t + 1)$ and t respectively.

Once minima is reached through this iterative process, the gradient of the cost function at minima would technically be zero, and hence there would be no further updates to θ . However, because of rounding errors and other limitations of computers, converging to true minima might not be achievable. Thus, we would have to come up with some other logic to stop the iterative process when we believe we have reached minima—or at least close enough to the minima—to stop the iterative process of model training. One of the ways generally used is to check the magnitude of the gradient vector and if it is less than some predefined minute quantity—say, ϵ —stop the iterative process. The other crude way that can be used is to stop the iterative process of the parameter update after a fixed number of iterations, like 1000.

Learning rate plays a very vital role in the convergence of the gradient descent to the minima point. If the learning rate is large, the convergence might be faster but might lead to severe oscillations around the point of minima. A small learning rate might take a longer time to reach the minima, but the convergence is generally oscillation free.

To see why gradient descent works, let's take a model that has one parameter and a cost function $C(\theta) = (\theta - a)^2 + b$ and see why the method works.

As we can see from Figure 1-37, the gradient (in this case it's just the derivative) at point θ_1 is positive, and thus if we move along the gradient direction the cost function would increase. Instead, at θ_1 if we move along the negative of the gradient the cost reduces. Again, let's take the point θ_2 where the gradient is negative. If we take the gradient direction here for updating θ , the cost function would increase. Taking the negative direction of the gradient would ensure that we move toward the minima. Once we reach the minima at $\theta = a$, the gradient is 0, and hence there would be no further update to θ .

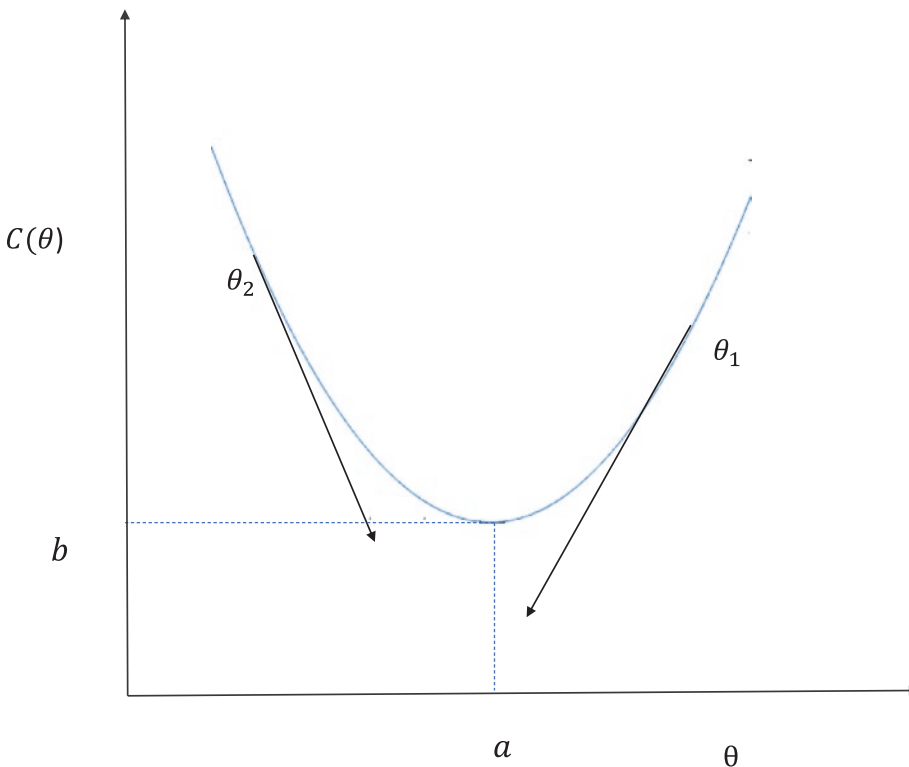

Figure 1-37. Gradient descent intuition with simple cost function in one variable

Gradient Descent for a Multivariate Cost Function

Now that we have some intuition about gradient descent from looking at a cost function based on one parameter, let's look at gradient descent when the cost function is based on multiple parameters.

Let's look at a Taylor Series expansion of a function of multiple variables. Multiple variables can be represented by the vector θ . Let's consider a cost function $C(\theta)$ where $\theta \in \mathbb{R}^{m \times 1}$.

As discussed earlier, the Taylor Series expansion around a point θ can be expressed in matrix notation, as shown here:

$$C(\theta + \Delta\theta) = C(\theta) + \Delta\theta^T \nabla C(\theta) + \frac{1}{2} \Delta\theta^T H(\theta) \Delta\theta + \text{higher order terms}$$

$\Delta\theta \rightarrow$ Change in θ vector

$\nabla C(\theta) \rightarrow$ Gradient vector of $C(\theta)$

$H(\theta) \rightarrow$ Hessian matrix of $C(\theta)$

Let's suppose at iteration t of gradient descent the model parameter is θ and we want update θ to $(\theta + \Delta\theta)$ by making an update of $\Delta\theta$ such that $C(\theta + \Delta\theta)$ is lesser than $C(\theta)$.

If we assume linearity of the function in the neighborhood of θ , then from Taylor Series expansion we get the following:

$$C(\theta + \Delta\theta) = C(\theta) + \Delta\theta^T \nabla C(\theta)$$

We want to choose $\Delta\theta$ in such a way that $C(\theta + \Delta\theta)$ is less than $C(\theta)$.

For all $\Delta\theta$ with the same magnitude, the one that will maximize the dot product $\Delta\theta^T \nabla C(\theta)$ should have a direction the same as that of $\nabla C(\theta)$. But that would give us the maximum possible $\Delta\theta^T \nabla C(\theta)$. Hence, to get the minimum value of the dot product $\Delta\theta^T \nabla C(\theta)$, the direction of $\Delta\theta$ should be the exact opposite of that of $\nabla C(\theta)$. In other words, $\Delta\theta$ should be proportional to the negative of the gradient vector $\nabla C(\theta)$:

$$\Delta\theta \propto -\nabla C(\theta)$$

$\Rightarrow \Delta\theta = -\eta \nabla C(\theta)$, where η is the learning rate

$$\Rightarrow \theta + \Delta\theta = \theta - \eta \nabla C(\theta)$$

$$\Rightarrow \theta^{(t+1)} = \theta^{(t)} - \eta \nabla C(\theta^{(t)})$$

which is the famous equation for gradient descent. To visualize how the gradient descent proceeds to the minima, we need to have some basic understanding of contour plots and contour lines.

Contour Plot and Contour Lines

Let us consider a function $C(\theta)$ where $\theta \in \mathbb{R}^{n \times 1}$. A contour line is a line/curve in the vector space of θ that connects points that have the same value of the function $C(\theta)$. For each unique value of $C(\theta)$ we would have separate contour lines.

Let's plot the contour lines for a function $C(\theta) = \theta^T A \theta$, where $\theta = [\theta_1, \theta_2]^T \in \mathbb{R}^{2 \times 1}$ and

$$A = \begin{bmatrix} 7 & 2 \\ 2 & 5 \end{bmatrix}$$

Expanding the expression for $C(\theta)$ we get

$$C(\theta_1, \theta_2) = 7\theta_1^2 + 5\theta_2^2 + 4\theta_1\theta_2$$

The contour plot for the cost function is depicted in Figure 1-38.

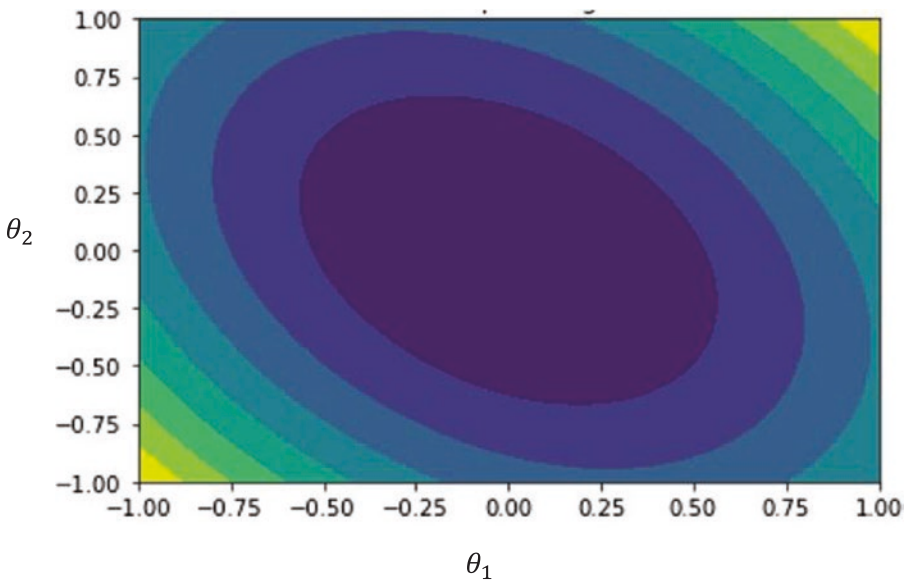

Figure 1-38. Contour plots

Each of the ellipses are contour lines specific to a fixed value of the function $C(\theta_1, \theta_2)$. If $C(\theta_1, \theta_2) = a$, where a is a constant, then the equation

$$a = 7\theta_1^2 + 5\theta_2^2 + 4\theta_1\theta_2$$
 represents an ellipse.

For different values of constant a we get different ellipses, as depicted in Figure 1-38. All points on a specific contour line have the same value of the function.

Now that we know what a contour plot is, let's look at gradient descent progression in a contour plot for the cost function $C(\theta)$, where $\theta \in \mathbb{R}^{2 \times 1}$. The gradient descent steps have been illustrated in Figure 1-39.

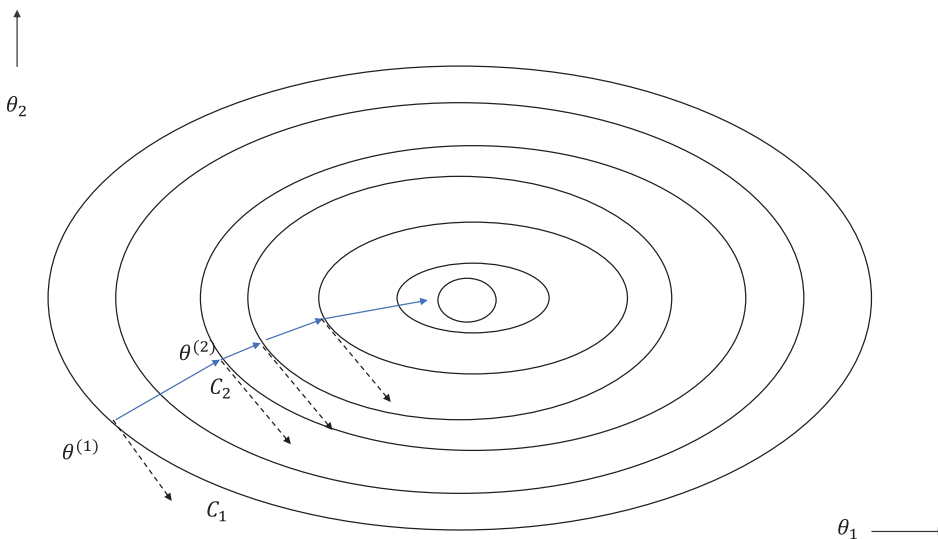

Figure 1-39. Gradient descent for a two-variable cost function

Let's take the largest ellipse corresponding to cost C_1 and assume our current θ is at the point $\theta^{(1)}$ in C_1 . Assuming the linearity of the $C(\theta)$ about θ , the change in cost function $C(\theta)$ can be presented as seen here:

$$\Delta C(\theta) = \Delta\theta^T \nabla C(\theta)$$

If we take a small change in cost between two points very close to each other in the same contour line, then $\Delta C(\theta) = 0$, since all points on the same contour line have the same fixed value. Also, it should be noted that when we take two points very close to each other on the same contour line, the $\Delta\theta$ represents the tangent to the contour line represented by tangential arrows to the contour line. Please do not confuse this $\Delta\theta$ to be the $\Delta\theta$ update to the parameter in gradient descent.

$\Delta C(\theta) = 0 \rightarrow \Delta\theta^T \nabla C(\theta) = 0$, which basically means that the gradient is perpendicular to the tangent at the point $\theta^{(1)}$ in the contour line C_1 . The gradient would have pointed outward, whereas the negative of the gradient points inward, as depicted by the arrow perpendicular to the tangent. Based on the learning rate, it will reach a point $\theta^{(2)}$ in a different contour line represented by C_2 , whose cost function value would be less than that of C_1 . Again, the gradient would be evaluated at $\theta^{(2)}$, and the same process would be repeated for several iterations until it reached the minima point, where the gradient would drop to 0 technically, after which there would be no more updates to θ .

Steepest Descent

Steepest descent is a form of gradient descent where the learning rate is not constant but rather is computed at every iteration to ensure that the parameter update through gradient descent takes the cost function to minima with respect to the learning rate. In other words, the learning rate at every iteration in steepest descent is optimized to ensure that the movement in the direction of the gradient is utilized to the maximum extent.

Let us take our usual cost function $C(\theta)$ and look at successive iterations t and $(t+1)$. As with gradient descent, we have the parameter update rule as follows:

$$\theta^{(t+1)} = \theta^{(t)} - \eta \nabla C(\theta^{(t)})$$

So, the cost function at iteration $(t+1)$ can be expressed as

$$C(\theta^{(t+1)}) = C(\theta^{(t)} - \eta \nabla C(\theta^{(t)}))$$

To minimize the cost function at iteration $(t+1)$ with respect to the learning rate, see the following:

$$\begin{aligned} \frac{\partial C(\theta^{(t+1)})}{\partial \eta} &= 0 \\ \Rightarrow \nabla C(\theta^{(t+1)}) \frac{\partial [C(\theta^{(t)} - \eta \nabla C(\theta^{(t)}))]}{\partial \eta} &= 0 \end{aligned}$$

$$\Rightarrow -\nabla C(\theta^{(t+1)})^T \nabla C(\theta^{(t)}) = 0$$

$$\Rightarrow \nabla C(\theta^{(t+1)})^T \nabla C(\theta^{(t)}) = 0$$

So, for steepest descent, the dot product of the gradients at $(t+1)$ and t is 0, which implies that the gradient vector at every iteration should be perpendicular to the gradient vector at its previous iteration.

Stochastic Gradient Descent

Both steepest descent and gradient descent are full-batch models; i.e., the gradients are computed based on the whole training dataset. So, if the dataset is huge, the gradient computation becomes expensive and the memory requirement increases. Also, if the dataset has huge redundancy, then computing the gradient on the full dataset is not useful since similar gradients can be computed by using much smaller batches called mini batches. The most popular method to overcome the preceding problems is to use an optimization technique called stochastic gradient descent.

Stochastic gradient descent is a technique for minimizing a cost function based on the gradient descent method where the gradient at each step is not based on the entire dataset but rather on single data points.

Let $C(\theta)$ be the cost function based on m training samples. The gradient descent at each step is not based on $C(\theta)$ but rather on $C^{(i)}(\theta)$, which is the cost function based on the i th training sample. So, if we must plot the gradient vectors at each iteration against the overall cost function, the contour lines would not be perpendicular to the tangents since they are based on gradients of $C^{(i)}(\theta)$ and not on the overall $C(\theta)$.

The cost functions $C^{(i)}(\theta)$ are used for gradient computation at each iteration, and the model parameter vector θ is updated by the standard gradient descent in each iteration until we have made a pass over the entire training dataset. We can perform several such passes over the entire dataset until a reasonable convergence is obtained.

Since the gradients at each iteration are not based on the entire training dataset but rather on single training samples, they are generally very noisy and may change direction rapidly. This may lead to oscillations near the minima of the cost function, and hence the learning rate should be less while converging to the minima so that the update to the parameter vector is as small as possible. The gradients are cheaper and faster to compute, and so the gradient descent tends to converge faster.

One thing that is important in stochastic gradient descent is that the training samples should be as random as possible. This will ensure that a stochastic gradient descent over a period of a few training samples provides a similar update to the model parameter as that resulting from an actual gradient descent, since the random samples are more likely to represent the total training dataset. If the samples at each iteration of stochastic gradient descent are biased, they don't represent the actual dataset, and hence the update to the model parameter might be in a direction that would result in it taking a long time for the stochastic gradient descent to converge.

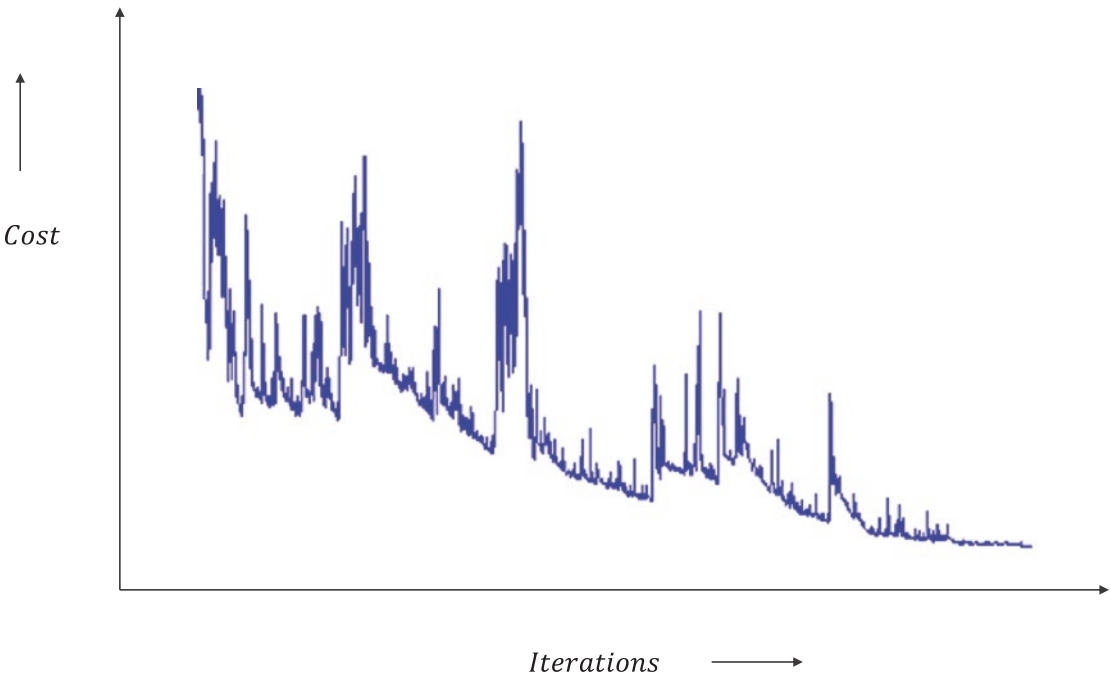

Figure 1-40. Fluctuation in the total cost function value over iterations in stochastic gradient descent

As illustrated in Figure 1-41, the gradients at each step for stochastic gradient descent are not perpendicular to the tangents at the contour lines. However, they would be perpendicular to the tangents to the contour lines for individual training samples had we plotted them. Also, the associated cost reduction over iterations is noisy because of the fluctuating gradients.

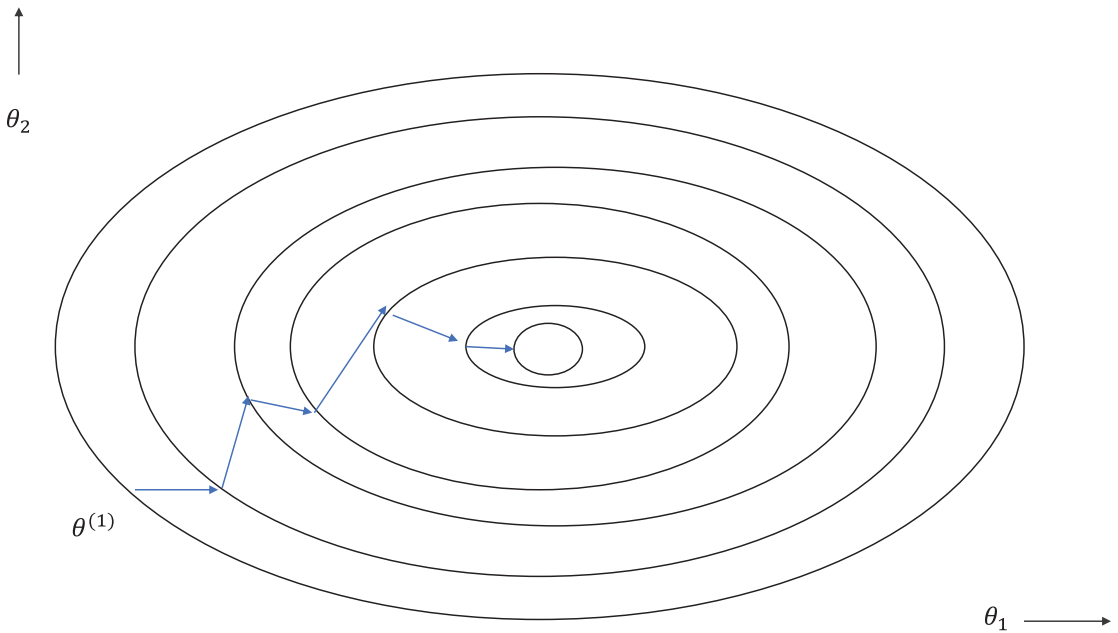

Figure 1-41. Stochastic gradient descent parameter update

The gradient computations become very cheap when we use single training data points. Also, convergence is quite fast, but it does come with its own set of disadvantages, as follows:

- Since the estimated gradients at each iteration are not based on the total cost function but rather on the cost function associated with single data points, the gradients are very noisy. This leads to convergence problems at the minima and may lead to oscillations.
- The tuning of the learning rate becomes important since a high learning rate might lead to oscillations while converging to the minima. This is because the gradients are very noisy, and hence if the gradient estimates at the convergence are not near to zero a high learning rate will take the update well past the minima point and the process can repeat on either side of the minima.
- Since the gradients are noisy, the model parameter values after each iteration are also very noisy, and thus heuristics need to be added to the stochastic gradient descent to determine which value of model parameter to take. This also brings about another question: when to stop the training.

A compromise between full-batch model and stochastic gradient descent is a mini-batch approach wherein the gradient is neither based on the full training dataset nor on the single data points. Rather, it uses a mini batch of training data points to compute the cost function. Most of the deep-learning algorithms use a mini-batch approach for stochastic gradient descent. The gradients are less noisy and at the same time don't cause many memory constraints because the mini-batch sizes are moderate.

We will discuss mini-batches in more detail in Chapter 2.

Newton's Method

Before we start Newton's method for optimizing a cost function for its minima, let's look at the limitations of gradient-descent techniques.

Gradient-descent methods rely on the linearity of the cost function between successive iterations; i.e., the parameter value at iteration $(t+1)$ can be reached from the parameter value at time t by following the gradient, since the path of the cost function $C(\theta)$ from t to $(t+1)$ is linear or can be joined by a straight line.

This is a very simplified assumption and would not yield good directions for gradient descent if the cost function is highly non-linear or has curvature. To get a better idea of this, let's look at the plot of a cost function with a single variable for three different cases.

Linear Curve

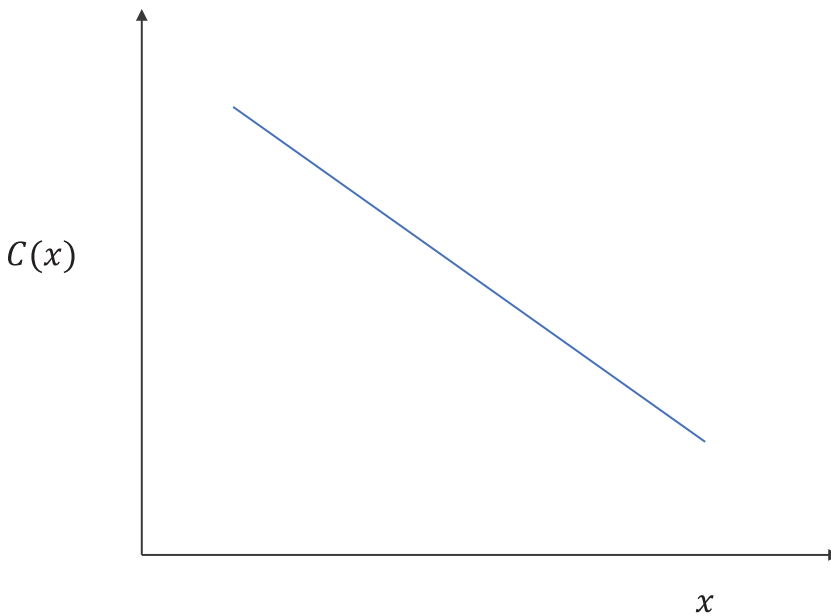

Linear function

Figure 1-42. Linear cost function

Negative Curvature

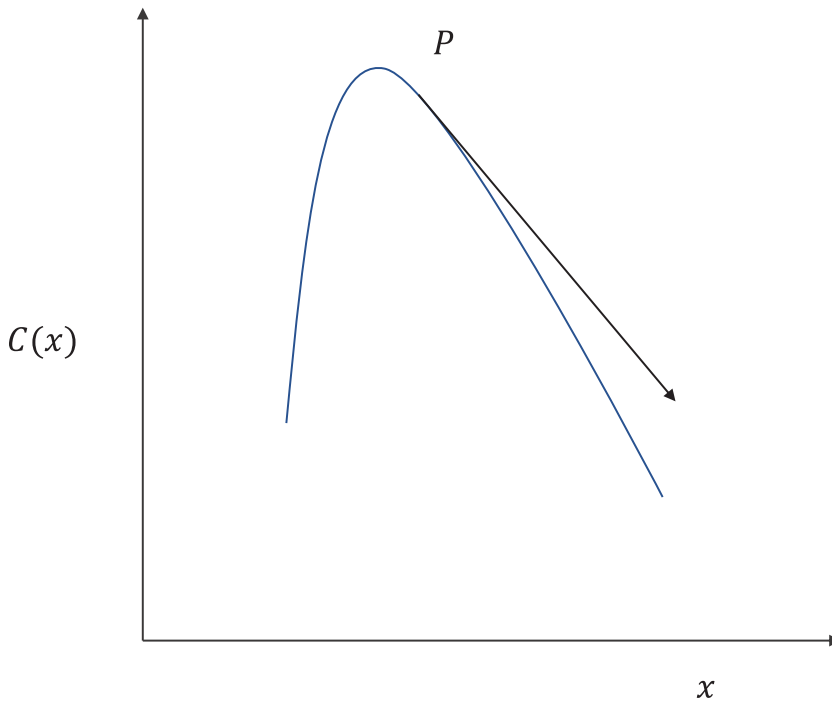

Negative Curvature

Figure 1-43. Cost function with negative curvature at point P

Positive Curvature

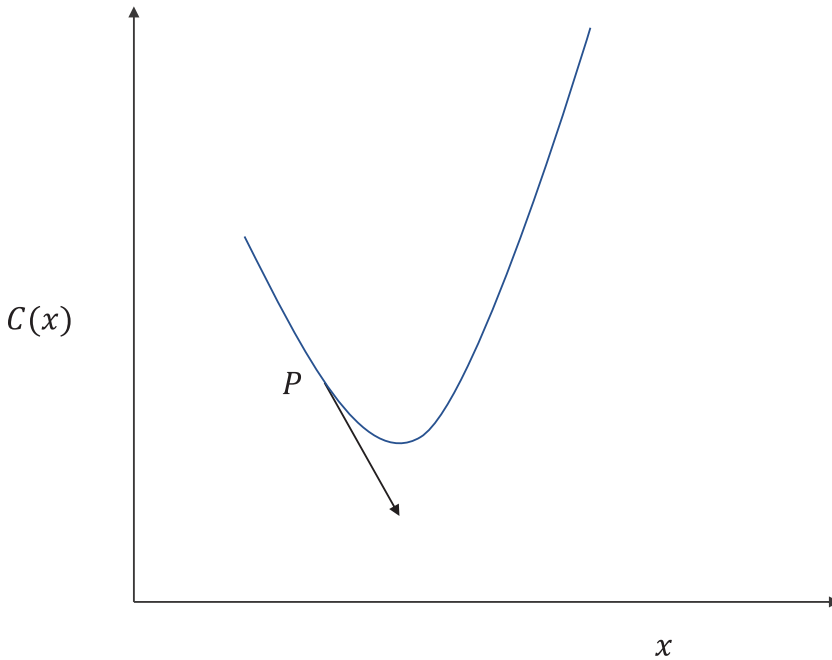

Positive Curvature

Figure 1-44. Cost function with positive curvature at point *P*

For the linear cost function, as shown in Figure 1-42, the negative of the gradient would give us the best direction for reaching the minima since the function is linear and doesn't have any curvature. For both the negative and positive curvature cost functions, shown in Figures 1-43 and 1-44 respectively, the derivative would not give us a good direction for minima, and so to take care of the curvature we would need the Hessian along with the derivative. Hessians, as we have seen, are nothing but a matrix of second derivatives. They contain information about the curvature and thus would give a better direction for a parameter update as compared to a simple gradient descent.

Gradient-descent methods are first-order approximation methods for optimization whereas Newton's methods are second-order methods for optimization since they use the Hessian along with the gradient to take care of curvatures in the cost function.

Let's take our usual cost function $C(\theta)$, where $\theta \in \mathbb{R}^{n \times 1}$ is an n -dimensional model parameter vector. We can approximate the cost function $C(\theta)$ in the neighborhood of θ by its second-order Taylor series expansion, as shown here:

$$C(\theta + \Delta\theta) = C(\theta) + \Delta\theta^T \nabla C(\theta) + \frac{1}{2} \Delta\theta^T H(\theta) \Delta\theta$$

$\nabla C(\theta)$ is the gradient and $H(\theta)$ is the Hessian of the cost function $C(\theta)$.

Now, if θ is the value of the model parameter vector at iteration t , and $(\theta + \Delta\theta)$ is the value of the model parameter at iteration $(t+1)$, then

$$C(\theta^{(t+1)}) = C(\theta^{(t)}) + \Delta\theta^T \nabla C(\theta^{(t)}) + \frac{1}{2} \Delta\theta^T H(\theta^{(t)}) \Delta\theta$$

$$\text{where } \Delta\theta = \theta^{(t+1)} - \theta^{(t)}.$$

Taking the gradient with respect to $\theta^{(t+1)}$ we have

$$\nabla C(\theta^{(t+1)}) = \nabla C(\theta^{(t)}) + H(\theta^{(t)}) \Delta\theta$$

Setting the gradient $\nabla C(\theta^{(t+1)})$ to 0 we get

$$\nabla C(\theta^{(t)}) + H(\theta^{(t)}) \Delta\theta = 0$$

$$\Rightarrow \Delta\theta = -H(\theta^{(t)})^{-1} \nabla C(\theta^{(t)})$$

So, the parameter update for Newton's method is as follows:

$$\Rightarrow \theta^{(t+1)} = \theta^{(t)} - H(\theta^{(t)})^{-1} \nabla C(\theta^{(t)})$$

We don't have a learning rate for Newton's method, but one may choose to use a learning rate, much like with gradient descent. Since the directions for non-linear cost functions are better with Newton's method, the iterations to converge to the minima would be fewer as compared to gradient descent. One thing to note is that if the cost function that we are trying to optimize is a quadratic cost function, such as the one in linear regression, then Newton's method would technically converge to the minima in one step.

However, computing the Hessian matrix and its inverse is computationally expensive or intractable at times, especially when the number of input features is large. Also, at times there might be functions for which the Hessian is not even properly defined. So, for large machine-learning and deep-learning applications, gradient descent—especially Stochastic gradient descent—techniques with mini batches are used since they are relatively less computationally intensive and scale up well when the data size is large.

Constrained Optimization Problem

In a constrained optimization problem, along with the cost function that we need to optimize, we have a set of constraints that we need to adhere to. The constraints might be equations or inequalities.

Whenever we want to minimize a function that is subject to an equality constraint, we use the Lagrange formulation. Let's say we must minimize $f(\theta)$ subject to $g(\theta) = 0$ where $\theta \in \mathbb{R}^{n \times 1}$. For such a constrained optimization problem, we need to minimize a function $L(\theta, \lambda) = f(\theta) + \lambda g(\theta)$. Taking the gradient of L , which is called the Lagrangian, with respect to the combined vector θ, λ , and setting it to 0 would give us the

required θ that minimizes $f(\theta)$ and adheres to the constraint. λ is called the Lagrange multiplier. When there are several constraints, we need to add all such constraints, using a separate Lagrange multiplier for each constraint. Let's say we want to minimize $f(\theta)$ subject to m constraints $g_i(\theta) = 0 \quad \forall i \in \{1, 2, 3, \dots, m\}$; the Lagrangian can be expressed as follows:

$$L(\theta, \lambda) = f(\theta) + \sum_{i=1}^m \lambda_i g_i(\theta)$$

where $\lambda = [\lambda_1 \lambda_2 \dots \lambda_m]^T$

To minimize the function, the gradient of $L(\theta, \lambda)$ with respect to both θ and λ vectors should be a zero vector; i.e.,

$$\nabla_{\theta} L(\theta, \lambda) = 0$$

$$\nabla_{\lambda} L(\theta, \lambda) = 0$$

The preceding method can't be directly used for constraints with inequality. In such cases, a more generalized approach called the Karush Kahn Tucker method can be used.

Let $C(\theta)$ be the cost function that we wish to minimize, where $\theta \in \mathbb{R}^{n \times 1}$. Also, let there be k number of constraint on θ such that

$$f_1(\theta) = a_1$$

$$f_2(\theta) = a_2$$

$$f_3(\theta) \leq a_3$$

$$f_4(\theta) \geq a_4$$

...

...

$$f_k(\theta) = a_k$$

This becomes a constrained optimization problem since there are constraints that θ should adhere to. Every inequality can be transformed into a standard form where a certain function is less than or less than equal to zero. For example:

$$f_4(\theta) \geq a_4 \Rightarrow -f_4(\theta) \leq -a_4 \Rightarrow -f_4(\theta) + a_4 \leq 0$$

Let each such constraint strictly less than, or less than equal to, zero be represented by $g_i(\theta)$. Also, let there be some strict equality equations $e_j(\theta)$. Such minimization problems are solved through the Karush Kuhn Tucker version of Lagrangian formulation.

Instead of minimizing $C(\theta)$, we need to minimize a cost function $L(\theta, \alpha, \beta)$ as follows:

$$L(\theta, \alpha, \beta) = C(\theta) + \sum_{i=1}^{k_1} \alpha_i g_i(\theta) + \sum_{j=1}^{k_2} \beta_j e_j(\theta)$$

The scalars $\alpha_i \forall i \in \{1, 2, 3, \dots, k_1\}$ and $\beta_j \forall j \in \{1, 2, 3, \dots, k_2\}$ are called the Lagrangian multipliers, and there would be k of them corresponding to k constraints. So, we have converted a constrained minimization problem into an unconstrained minimization problem.

To solve the problem, the Karush Kuhn Tucker conditions should be met at the minima point as follows:

- The gradient of $L(\theta, \alpha, \beta)$ with respect to θ should be the zero vector; i.e.,

$$\nabla_{\theta}(\theta, \alpha, \beta) = 0$$

$$\Rightarrow \nabla_{\theta} C(\theta) + \sum_{i=1}^{k_1} \alpha_i \nabla_{\theta} g_i(\theta) + \sum_{j=1}^{k_2} \beta_j \nabla_{\theta} e_j(\theta) = 0$$

- The gradient of the $L(\theta, \alpha, \beta)$ with respect to β , which is the Lagrange multiplier vector corresponding to the equality conditions, should be zero:

$$\nabla_{\beta}(\theta, \alpha, \beta) = 0$$

$$\Rightarrow \nabla_{\beta} C(\theta) + \sum_{i=1}^{k_1} \alpha_i \nabla_{\beta} g_i(\theta) + \sum_{j=1}^{k_2} \beta_j \nabla_{\beta} e_j(\theta) = 0$$

- The inequality conditions should become equality conditions at the minima point. Also, the inequality Lagrange multipliers should be non-negative:

$$\alpha_i g_i(\theta) = 0 \text{ and } \alpha_i \geq 0 \quad \forall i \in \{1, 2, \dots, k_1\}$$

Solving for the preceding conditions would provide the minima to the constrained optimization problem.

A Few Important Topics in Machine Learning

In this section, we will discuss a few important topics that are very much relevant to machine learning. Their underlying mathematics is very rich.

Dimensionality Reduction Methods

Principal component analysis and singular value decomposition are the most commonly used dimensionality-reduction techniques in the machine-learning domain. We will discuss these techniques to some extent here. Please note that these data-reduction techniques are based on linear correlation and don't capture non-linear correlation such as co-skewness, co-Kurtosis, and so on. We will talk about a few dimensionality-reduction techniques that are based on artificial neural networks, such as auto-encoders, in the latter part of the book.

Principal Component Analysis

Principal component analysis is a dimensionality-reduction technique that ideally should have been discussed in the “Linear Algebra” section. However, to make its mathematics much easier to grasp, I intentionally kept it for after the constrained optimization problem. Let’s look at the two-dimensional data plot in Figure 1-45. As we can see, the maximum variance of the data is neither along the x direction nor along the y direction, but somewhat in a direction in between. So, had we projected the data in a direction where the variance is at maximum, it would have covered most of the variability in the data. Also, the rest of the variance could have been ignored as noise.

The data along the x direction and the y direction are highly correlated (see Figure 1-45). The covariance matrix would provide the required information about the data to reduce the redundancy. Instead of looking at the x and y directions we can look at the a_1 direction, which has the maximum variance.

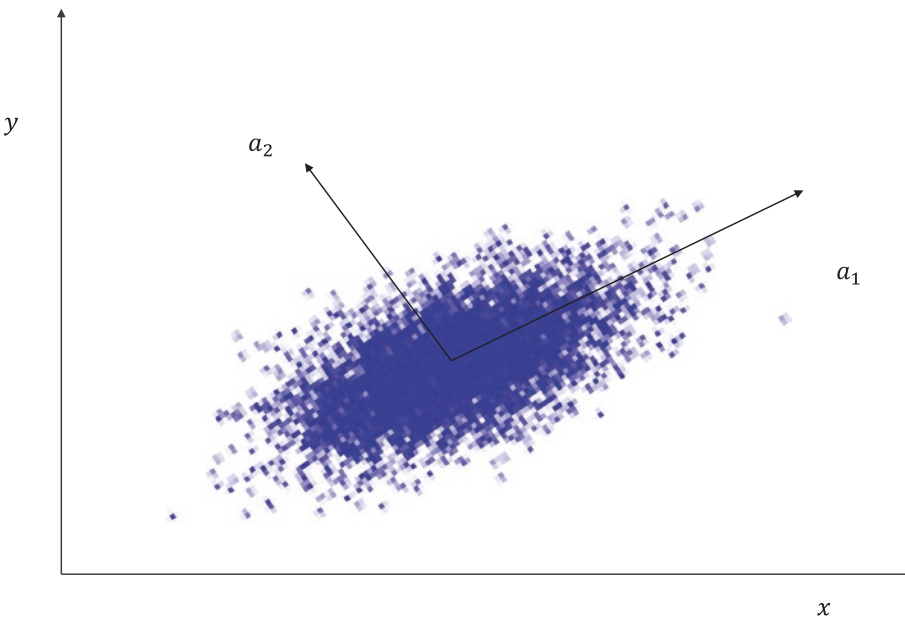

Figure 1-45. Correlated 2-D data. a_1 and a_2 are the directions along which the data is uncorrelated and are the principal components.

Now, let’s get into some math and assume that we don’t have the plot and we only have the data for m number of samples $x^{(i)} \in \mathbb{R}^{n \times 1}$.

We want to find out independent directions in the n -dimensional plane in the order of decreasing variances. By independent directions I mean the covariance between those directions should be 0. Let a_1 be the unit vector along which the variance of the data is maximum. We first subtract the mean of the data vector to center the data on the origin. Let μ be the mean vector of the data vector x ; i.e., $E[x] = \mu$.

A component of the $(x - \mu)$ vector in the direction of a_1 is the projection of $(x - \mu)$ on a_1 ; let it be denoted by z_1 :

$$z_1 = a_1^T (x - \mu)$$

$var(z_1) = var[a_1^T (x - \mu)] = a_1^T cov(x) a_1$, where var denotes variance and $cov(x)$ denotes the covariance matrix.

For given data points the variance is a function of a_1 . So, we would have to maximize the variance with respect to a_1 given that a_1 is a unit vector:

$$a_1^T a_1 = 1 \Rightarrow a_1^T a_1 - 1 = 0$$

So, we can express the function to be maximized as

$$L(a_1, \lambda) = a_1^T cov(x) a_1 - \lambda (a_1^T a_1 - 1), \text{ where } \lambda \text{ is a Lagrangian multiplier.}$$

For maxima, setting the gradient of L with respect to a_1 to 0, we get

$$\nabla L = 2cov(x) a_1 - 2\lambda a_1 = 0 \Rightarrow cov(x) a_1 = \lambda a_1$$

We can see something come up that we studied earlier. The a_1 vector is nothing but an Eigen vector of the covariance matrix, and λ is the corresponding Eigen value.

Now, substituting this into the variance expression along a_1 , we get

$$var(z_1) = a_1^T cov(x) a_1 = a_1^T \lambda a_1 = \lambda a_1^T a_1 = \lambda$$

Since the expression for variance along a_1 is the Eigen value itself, the Eigen vector corresponding to the highest Eigen value gives us the first principal component, or the direction along which the variance in data is maximum.

Now, let's get the second principal component, or the direction along which the variance is maximum right after a_1 .

Let the direction of the second principal component be given by the unit vector a_2 . Since we are looking for orthogonal components, the direction of a_2 should be perpendicular to a_1 .

A projection of the data along a_2 can be expressed by the variable $z_2 = a_2^T (x - \mu)$.

Hence, the variance of the data along a_2 is $Var(z_2) = Var[a_2^T (x - \mu)] = a_2^T cov(x) a_2$.

We would have to maximize $Var(z_2)$ subject to the constraints $a_2^T a_2 = 1$ since a_2 is a unit vector and $a_2^T a_1 = 0$ since a_2 should be orthogonal to a_1 .

We need to maximize the following function $L(a_2, \alpha, \beta)$ with respect to the parameters a_2, α, β :

$$L(a_2, \alpha, \beta) = a_2^T cov(x) a_2 - \alpha (a_2^T a_2 - 1) - \beta (a_2^T a_1)$$

By taking a gradient with respect to a_2 and setting it to zero vector we get

$$\nabla L = 2cov(x) a_2 - 2\alpha a_2 - \beta a_1 = 0$$

By taking the dot product of the gradient ∇L with vector a_1 we get

$$2a_1^T cov(x) a_2 - 2\alpha a_1^T a_2 - \beta a_1^T a_1 = 0$$

$a_1^T cov(x) a_2$ is a scalar and can be written as $a_2^T cov(x) a_1$.

On simplification, $a_2^T cov(x)a_1 = a_2^T \lambda a_1 = \lambda a_2^T a_1 = 0$. Also, the term $2\alpha a_1^T a_2$ is equal to 0, which leaves $\beta a_1^T a_1 = 0$. Since $a_1^T a_1 = 1$, β must be equal to 0.

Substituting $\beta = 0$ in the expression for $\nabla L = 2cov(x)a_2 - 2\alpha a_2 - \beta a_1 = 0$, we have the following:

$$2cov(x)a_2 - 2\alpha a_2 = 0 \text{ i.e. } cov(x)a_2 = \alpha a_2$$

Hence, the second principal component is also an Eigen vector of the covariance matrix, and the Eigen value α must be the second-largest Eigen value just after λ . In this way, we would get n Eigen vectors from the covariance matrix $cov(x) \in \mathbb{R}^{n \times 1}$, and the variance of the data along each of those Eigen value directions (or principal components) would be represented by the Eigen values. One thing to note is that the covariance matrix is always symmetrical and thus the Eigen vectors would always be orthogonal to each other and so would give independent directions.

The covariance matrix is always positive semi-definite.

This is true because the Eigen values of the covariance matrix represent variances, and variance can't be negative. If $cov(x)$ is positive definite, i.e., $a^T cov(x)a > 0$, then all the Eigen values of covariance matrices are positive.

Figure 1-46 illustrates a principal component analysis transformation of the data. As we can see, PCA has centered the data and got rid of correlation among the PCA transformed variables.

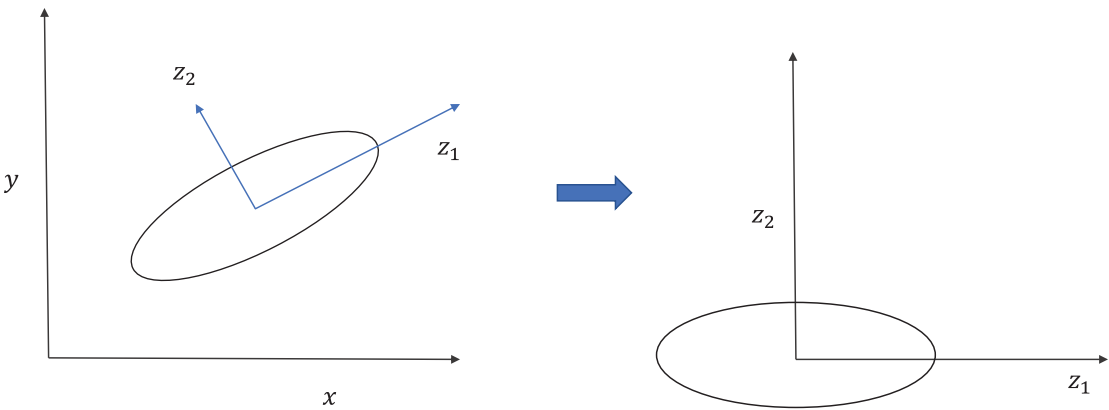

Figure 1-46. Principal component analysis centers the data and then projects the data into axes along which variance is maximum. The data along z_2 can be ignored if the variance along it is negligible.

When Will PCA Be Useful in Data Reduction?

When there is high correlation between the different dimensions of the input, there would only be a few independent directions along which the variance of data would be high, and along other directions the variance would be insignificant. With PCA, one can keep the data components in the few directions in which variance is high and make a significant contribution to the overall variance, ignoring the rest of the data.

How Do You Know How Much Variance Is Retained by the Selected Principal Components?

If the z vector presents the transformed components for input vector x , then the $cov(z)$ would be a diagonal matrix containing the Eigen values of the $cov(x)$ matrix as its diagonal entries.

$$cov(z) = \begin{bmatrix} \lambda_1 & \cdots & 0 \\ \vdots & \lambda_2 & \vdots \\ 0 & \cdots & \lambda_n \end{bmatrix}$$

Also, let's suppose the Eigen values are ordered like $\lambda_1 > \lambda_2 > \lambda_3 \dots > \lambda_n$.

Let's suppose we choose to keep only the first k principal components; the proportion of variance in the data captured is as follows:

$$\frac{\lambda_1 + \lambda_2 + \lambda_3 + \dots + \lambda_k}{\lambda_1 + \lambda_2 + \lambda_3 + \dots + \lambda_k + \dots + \lambda_n}$$

Singular Value Decomposition

Singular value decomposition is a dimensionality-reduction technique that factorizes a matrix $A \in \mathbb{R}^{m \times n}$ into a product of three matrices, as $A = USV^T$ where

$U \in \mathbb{R}^{m \times m}$ and is composed of all the Eigen vectors of the matrix AA^T

$V \in \mathbb{R}^{n \times n}$ and is composed of all the Eigen vectors of the matrix $A^T A$

$S \in \mathbb{R}^{m \times n}$ and is composed of k square root of the Eigen vectors of both $A^T A$ and AA^T , where k is the rank of matrix A .

The column vectors of U are all orthogonal to each other and hence form an orthogonal basis. Similarly, the column vectors of V also form an orthogonal basis:

$$U = [u_1 u_2 \dots u_m]$$

where $u_i \in \mathbb{R}^{m \times 1}$ are the column vectors of U .

$$V = [v_1 v_2 \dots v_n]$$

where $v_i \in \mathbb{R}^{n \times 1}$ are the column vectors of V .

$$S = \begin{bmatrix} \sigma_1 & \cdots & 0 \\ \vdots & \sigma_2 & \vdots \\ 0 & \cdots & 0 \end{bmatrix}$$

Depending on the rank of A , there would be $\sigma_1, \sigma_2, \dots, \dots, \sigma_k$ diagonal entries corresponding to the rank k of matrix A :

$$A = \sigma_1 u_1 v_1^T + \sigma_2 u_2 v_2^T + \dots + \sigma_k u_k v_k^T$$

The $\sigma_i \forall i \in \{1, 2, 3, \dots, k\}$, also called singular values, are the square root of the Eigen values of both $A^T A$ and $A A^T$, and hence they are measures of variance in the data. Each of the $\sigma_i u_i v_i^T \forall i \in \{1, 2, 3, \dots, k\}$ is a rank-one matrix. We can only keep the rank-one matrices for which the singular values are significant and explain a considerable proportion of the variance in the data.

If one takes only the first p rank-one matrices corresponding to the first p singular values of largest magnitude, then the variance retained in the data is given by the following:

$$\frac{\sigma_1^2 + \sigma_2^2 + \sigma_3^2 + \dots + \sigma_p^2}{\sigma_1^2 + \sigma_2^2 + \sigma_3^2 + \dots + \sigma_p^2 + \dots + \sigma_k^2}$$

Images can be compressed using singular value decomposition. Similarly, singular value decomposition is used in collaborative filtering to decompose a user-rating matrix to two matrices containing user vectors and item vectors. The singular value decomposition of a matrix is given by USV^T . The user-ratings matrix R can be decomposed as follows:

$$R = USV^T = US^{\frac{1}{2}} S^{\frac{1}{2}} V^T = U' V'^T$$

where U' is the user-vector matrix and is equal to $US^{\frac{1}{2}}$ and V' is the items-vector matrix where $V' = S^{\frac{1}{2}} V^T$.

Regularization

The process of building a machine-learning model involves deriving parameters that fit the training data. If the model is simple, then the model lacks sensitivity to the variation in data and suffers from high bias. However, if the model is too complex, it tries to model for as much variation as possible and in the process models for random noise in the training data. This removes the bias produced by simple models but introduces high variance; i.e., the model is sensitive to very small changes in the input. High variance for a model is not a good thing, especially if the noise in the data is considerable. In such cases, the model in the pursuit of performing too well on the training data performs poorly on the test dataset since the model loses its capability to generalize well with the new data. This problem of models' suffering from high variance is called *overfitting*.

As we can see in Figure 1-47, we have three models fit to the data. The one parallel to the horizontal is suffering from high bias while the curvy one is suffering from high variance. The straight line in between at around 45 degrees to the horizontal has neither high variance nor high bias.

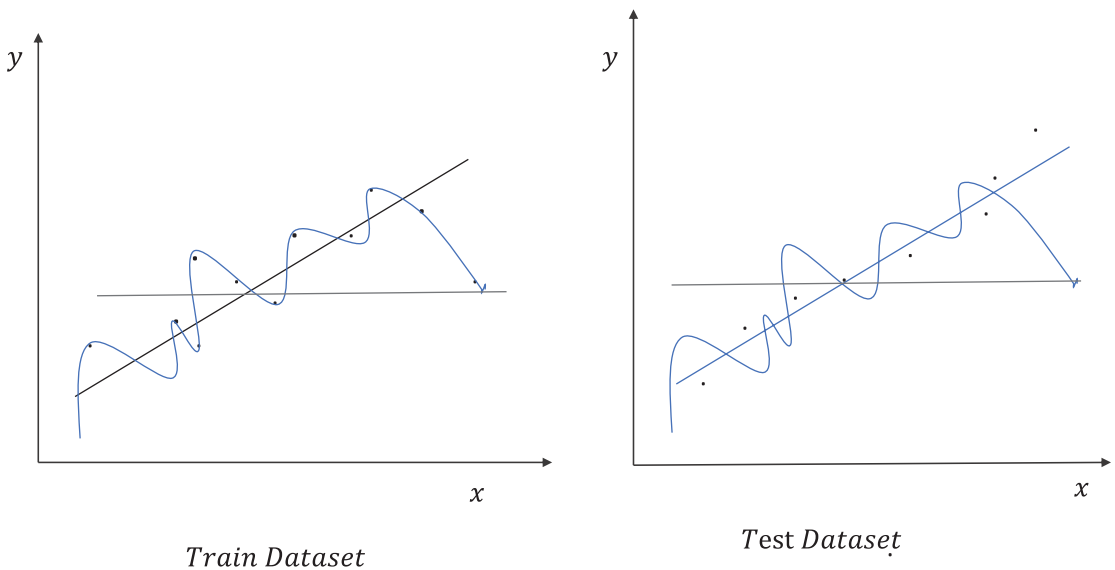

Figure 1-47. Illustration of models with high variance and high bias

The model with high variance does well on the train data but fails to do well on the test dataset, even when the dataset's nature hasn't changed much. The model represented in blue color may not fit the training perfectly, but it does better on the test data since the model doesn't suffer from high variance. The trick is to have a model that doesn't suffer from high bias and at the same time isn't so complex that it models for random noise as well.

Models with high variance typically have model parameters with a large magnitude since the sensitivity of the models to small changes in data is high. To overcome the problem of overfitting resulting from high model variance, a popular technique called regularization is widely used.

To put things into perspective, let's look at the linear regression cost function that we looked at earlier:

$$\begin{aligned} C(\theta) &= \|X\theta - Y\|_2^2 \\ &= (X\theta - Y)^T (X\theta - Y) \end{aligned}$$

As discussed earlier, models with high variance have model parameters with a large magnitude. We can put an extra component into the cost function $C(\theta)$ that penalizes the overall cost function in case the magnitude of the model parameter vector is high.

So, we can have a new cost function, $L(\theta) = \|X\theta - Y\|_2^2 + \lambda \|\theta\|_2^2$, where $\|\theta\|_2^2$ is the square of the L^2 norm of the model parameter vector. The optimization problem becomes

$$\theta^* = \underbrace{\text{Arg Min}}_{\theta} L(\theta) = \|X\theta - Y\|_2^2 + \lambda \|\theta\|_2^2$$

Taking the gradient ∇L with respect to θ and setting it to 0 gives us $\theta^* = (X^T X + \lambda I)^{-1} X^T Y$.

Now, as we can see because of the $\|\theta\|_2^2$ term in the cost function, the model parameter’s magnitude can’t be too large since it would penalize the overall cost function. λ determines the weight of the regularization term. A higher value for λ would result in smaller values of $\|\theta\|_2^2$, thus making the model simpler and prone to high bias or underfitting. In general, even smaller values of λ go a long way in reducing the model complexity and the model variance. λ is generally optimized using cross validation.

When the square of the l^2 norm is used as the regularization term, the optimization method is called l^2 regularization. At times, the l^1 norm of model parameter vectors is used as the regularization term, and the optimization method is termed l^1 regularization. l^2 regularization applied to regression problems is called ridge regression, whereas l^1 regularization applied to such regression problems is termed lasso regression.

For l^1 regularization, the preceding regression problem becomes

$$\theta^* = \underbrace{\text{Arg Min}}_{\theta} L(\theta) = \|X\theta - Y\|_2^2 + \lambda \|\theta\|_1$$

Ridge regression is mathematically more convenient since it has a closed-form solution whereas lasso regression doesn’t have a closed-form solution. However, lasso regression is much more robust to outliers in comparison to ridge regression. Lasso problems give sparse solutions, so it’s good for feature selection, especially when there is moderate to high correlation among the input features.

Regularization Viewed as a Constraint Optimization Problem

Instead of adding the penalty term, we can add a constraint on the magnitude of the model parameter vector to be less than or equal to some constant value. We can then have an optimization problem as follows:

$$\theta^* = \underset{\theta}{\text{argmin}} C(\theta) = \|X\theta - Y\|_2^2$$

such that $\|\theta\|_2^2 \leq b$

where b is a constant.

We can convert this constrained minimization problem to an unconstrained minimization problem by creating a new Lagrangian formulation, as seen here:

$$L(\theta, \lambda) = \|X\theta - Y\|_2^2 + \lambda (\|\theta\|_2^2 - b)$$

To minimize the Lagrangian cost function per the Karush Kuhn Tucker conditions, the following are important:

- The gradient of L with respect to θ ; i.e., $\nabla_{\theta} L(\theta, \lambda)$ should be the zero vector, which on simplification gives

$$\theta = (X^T X + \lambda I)^{-1} X^T Y \tag{1}$$

- Also at the optimal point $\lambda (\|\theta\|_2^2 - b) = 0$ and $\lambda \geq 0$

If we consider regularization, i.e., $\lambda > 0$, then $\|\theta\|_2^2 - b = 0$ (2)

As we can see from (1), θ obtained is a function of λ . λ should be adjusted such that the constraint from (2) is satisfied.

The solution $\theta = (X^T X + \lambda I)^{-1} X^T Y$ from (1) is the same as what we get from L^2 regularization. In machine-learning applications, the Lagrange multiplier is generally optimized through hyper parameter tuning or cross-validation since we have no knowledge of what a good value for b would be. When we take small values of λ the value of b increases and so does the norm of θ , whereas larger values of λ provide smaller b and hence a smaller norm for θ .

Coming back to regularization, any component in the cost function that penalizes the complexity of the model provides regularization. In tree-based models, as we increase the number of leaf nodes the complexity of the tree grows. We can add a term to the cost function that is based on the number of leaf nodes in the tree and it will provide regularization. A similar thing can be done for the depth of the tree.

Even stopping the model-training process early provides regularization. For instance, in gradient descent method the more iterations we run the more complex the model gets since with each iteration the gradient descent tries to reduce the cost-function value further. We can stop the model-learning process early based on some criteria, such as an increase in the cost function value for the test dataset in the iterative process. Whenever in the iterative process of training the training cost-function value decreases while the test cost-function value increases, it might be an indication of the onset of overfitting, and thus it makes sense to stop the iterative learning.

Whenever training data is less in comparison to the number of parameters the model must learn, there is a high chance of overfitting, because the model will learn too many rules for a small dataset and might fail to generalize well to the unseen data. If the dataset is adequate in comparison to the number of parameters, then the rules learned are over a good proportion of the population data, and hence the chances of model overfitting go down.

Summary

In this chapter, we have touched upon all the required mathematical concepts for proceeding with machine-learning and deep-learning concepts. The reader is still advised to go through proper text books pertaining to these subjects in his or her spare time for more clarity. However, this chapter is a good starting point. In the next chapter, we will start with artificial neural networks and the basics of TensorFlow.

CHAPTER 2



Introduction to Deep-Learning Concepts and TensorFlow

Deep Learning and Its Evolution

Deep learning evolved from artificial neural networks, which have existed since the 1940s. Neural networks are interconnected networks of processing units called artificial neurons that loosely mimic the axons found in a biological brain. In a biological neuron, dendrites receive input signals from various neighboring neurons, typically more than one thousand of them. These modified signals are then passed on to the cell body or soma of the neuron, where these signals are summed together and then passed on to the axon of the neuron. If the received input signal is more than a specified threshold, the axon will release a signal, which will be passed on to the neighboring dendrites of other neurons. Figure 2-1 depicts the structure of a biological neuron for reference.

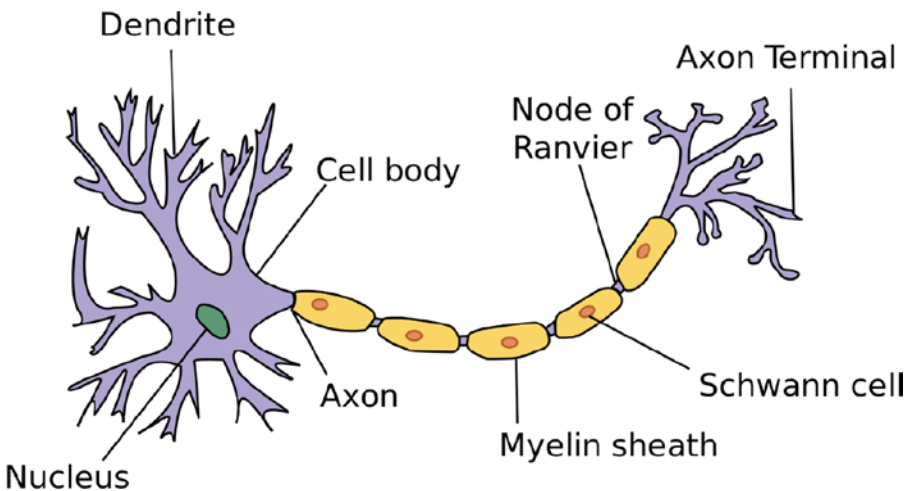

Figure 2-1. Structure of a biological neuron

Artificial neuron units are inspired by the biological neurons, with some modifications for convenience. Much like the dendrites, the input connections to the neuron carry the attenuated or amplified input signals from other neighboring neurons. The signals are passed on to the neuron, where the input signals are summed up and then a decision is made as to what to output based on the total input received. For instance, for a binary threshold neuron, an output value of 1 is provided when the total input exceeds a pre-defined threshold; otherwise, the output stays at 0. Several other types of neurons are used in artificial neural networks, and their implementation only differs with respect to the activation function on the total input to produce the neuron output. In Figure 2-2, the different biological equivalents are tagged in the artificial neuron for easy analogy and interpretation.

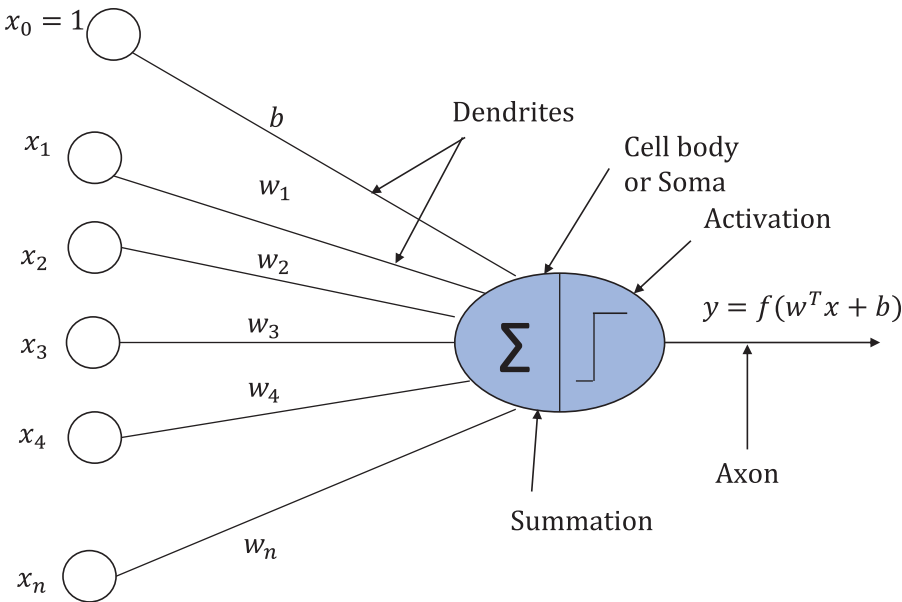

Figure 2-2. Structure of an artificial neuron

Artificial neural networks started with a lot of promise in the early 1940s. We will go through the chronology of major events in the artificial neural network community to get a feel of how this discipline has evolved over the years and what challenges were faced along the way.

- Warren McCulloch and Walter Pitts, two electrical engineers, published a paper titled “A Logical Calculus of the Ideas Immanent in Nervous Activity,” related to neural networks, in 1943. The paper can be located at <http://www.cs.cmu.edu/~epxing/Class/10715/reading/McCulloch.and.Pitts.pdf>. Their neurons have a binary output state, and there are two types of input to the neurons: excitatory inputs and inhibitory inputs. All excitatory inputs to the neuron have equal positive weights. If all the inputs to the neuron are excitatory and if the total input $\sum_i w_i x_i > 0$, the neuron would output 1. In cases where any of the inhibitory inputs are active or $\sum_i w_i x_i \leq 0$, the output would be 0. Using this logic, all the Boolean logic functions can be implemented by one or more such neurons. The drawback of these networks was that they had no way of learning the weights through training. One must figure out the weights manually and combine the neurons to achieve the required computation.

- The next big thing was the Perceptron, which was invented by Frank Rosenblatt in 1957. He, along with his collaborators, Alexander Stieber and Robert H. Shatz, documented their invention in a report titled *The Perceptron—A Perceiving and Recognizing Automaton*, which can be located at <https://blogs.umass.edu/brainwars/files/2016/03/rosenblatt-1957.pdf>. The Perceptron was built with the motive of binary classification tasks. Both the weights and bias to the neuron can be trained through the Perceptron learning rule. The weights can be both positive and negative. There were strong claims made by Frank Rosenblatt about the capabilities of the Perceptron model. Unfortunately, not all of them were true.
- Marvin Minsky and Seymour A. Papert wrote a book titled *Perceptrons: An Introduction to Computational Geometry* in 1969 (MIT Press), which showed the limitations of the Perceptron learning algorithm even on simple tasks such as developing the XOR Boolean function with a single Perceptron. A better part of the artificial neural network community perceived that these limitations showed by Minsky and Papert applied to all neural networks, and hence the research in artificial neural networks nearly halted for a decade, until the 1980s.
- In the 1980s, interest in artificial neural networks was revived by Geoffrey Hilton, David Rumelhart, Ronald Williams, and others, primarily because of the backpropagation method of learning multi-layered problems and because of the ability of neural networks to solve non-linear classification problems.
- In the 1990s, support vector machines (SVM), invented by V. Vapnik and C. Cortes, became popular since neural networks were not scaling up to large problems.
- Artificial neural networks were renamed deep learning in 2006 when Geoffrey Hinton and others introduced the idea of unsupervised pre-training and deep-belief networks. Their work on deep-belief networks was published in a paper titled “A Fast Learning Algorithm for Deep Belief Nets.” The paper can be located at <https://www.cs.toronto.edu/~hinton/absps/fastnc.pdf>.
- ImageNet, a large collection of labeled images, was created and released by a group in Stanford in 2010.
- In 2012, Alex Krizhevsky, Ilya Sutskever, and Geoffrey Hinton won the ImageNet Competition for achieving an error rate of 16 percent, whereas in the first two years the best models had around 28 percent and 26 percent error rates. This was a huge margin of win. The implementation of the solution had several aspects of deep learning that are standard in any deep-learning implementation today.
 - Graphical processing units (GPUs) were used to train the model. GPUs are very good at doing matrix operations and are computationally very fast since they have thousands of cores to do parallel computing.
 - Dropout was used as a regularization technique to reduce overfitting.
 - Rectified linear units (ReLU) were used as activation functions for the hidden layers.

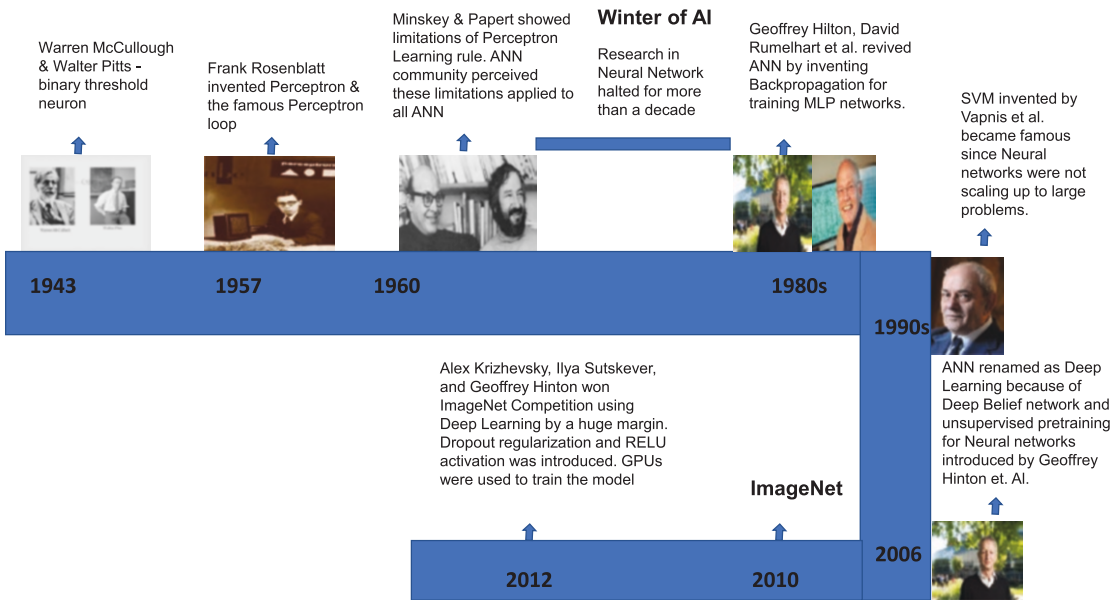

Figure 2-3. Evolution of artificial neural networks

Figure 2-3 shows the evolution of the artificial neural network into deep learning. ANN stands for artificial neural network, MLP stands for multi-layer Perceptron, and AI stands for artificial intelligence.

Perceptrons and Perceptron Learning Algorithm

Although there are limitations to what Perceptron learning algorithms can do, they are the precursor to the advanced techniques in deep learning we see today. Hence, a detailed study of Perceptrons and the Perceptron learning algorithm is worthwhile. Perceptrons are linear binary classifiers that use a hyperplane to separate the two classes. The Perceptron learning algorithm is guaranteed to fetch a set of weights and bias that classifies all the inputs correctly, provided such a feasible set of weights and bias exist.

Perceptron is a linear classifier, and as we saw in Chapter 1, linear classifiers generally perform binary classification by constructing a hyperplane that separates the positive class from the negative class.

The hyperplane is represented by a unit weight vector $w' \in \mathbb{R}^{m \times 1}$ that is perpendicular to the hyperplane and a bias term b that determines the distance of the hyperplane from the origin. The vector $w' \in \mathbb{R}^{m \times 1}$ is chosen to point toward the positive class.

As illustrated in Figure 2-4, for any input vector $x' \in \mathbb{R}^{n \times 1}$ the dot product with the negative of the unit vector $w' \in \mathbb{R}^{n \times 1}$ would give the distance b of the hyperplane from the origin since x' and w' are on the side opposite of the origin. Formally, for points lying on the hyperplane,

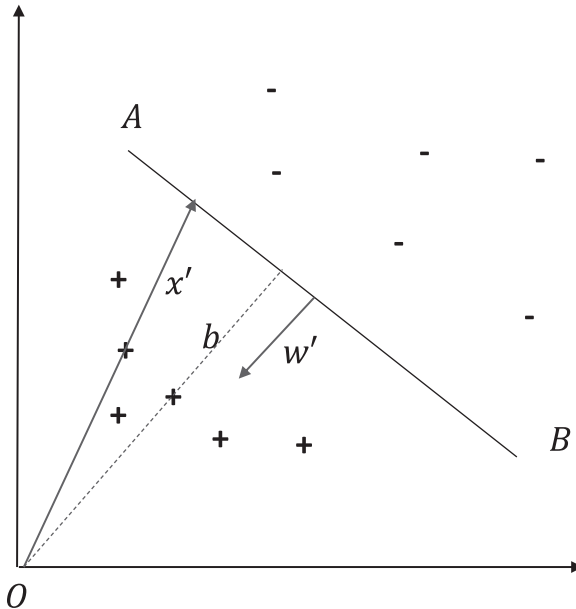

Figure 2-4. Hyperplane separating two classes

$$-w'^T x' = b \Rightarrow w'^T x' + b = 0$$

Similarly, for points lying below the hyperplane, i.e., the input vectors $x'_+ \in \mathbb{R}^{n \times 1}$ belonging to the positive class, the negative of the projection of x'_+ on w' should be less than b . So, for the points belonging to the positive class,

$$-w'^T x' < b \Rightarrow w'^T x' + b > 0$$

Similarly, for points lying above the hyperplane, i.e., the input vectors $x'_- \in \mathbb{R}^{n \times 1}$ belonging to the negative class, the negative of the projection of x'_- on w' should be greater than b . So, for the points belonging to the negative class,

$$-w'^T x' > b \Rightarrow w'^T x' + b < 0$$

Summarizing the preceding deductions, we can conclude the following:

- $w'^T x' + b = 0$ corresponds to the hyperplane and all $x' \in \mathbb{R}^{n \times 1}$ that lie on the hyperplane will satisfy this condition. Generally, points on the hyperplane are taken to belong to the negative class.

- $w'^T x' + b > 0$ corresponds to all points in the positive class.
- $w'^T x' + b \leq 0$ corresponds to all points in the negative class.

However, for Perceptron we don't keep the weight vector w' as a unit vector but rather keep it as any general vector. In such cases, the bias b would not correspond to the distance of the hyperplane from the origin, but rather it would be a scaled version of the distance from the origin, the scaling factor being the magnitude or the l^2 norm of the vector w' i. e. $\|w'\|_2$. Just to summarize, if w' is any general vector perpendicular to the hyperplane and is pointing toward the positive class, then $w'^T x + b = 0$ still represents a hyperplane where b represents the distance of the hyperplane from the origin times the magnitude of w' .

In the machine-learning domain, the task is to learn the parameters of the hyperplane (i.e., w' and b). We generally tend to simplify the problem to get rid of the bias term and consume it as a parameter within w corresponding to a constant input feature of 1,1 as we discussed earlier in Chapter 1.

Let the new parameter vector after adding the bias be $w \in \mathbb{R}^{(n+1) \times 1}$ and the new input features vector after adding the constant term 1 be $x \in \mathbb{R}^{(n+1) \times 1}$, where

$$x' = [x_1 \ x_2 \ x_3 \ \dots \ x_n]^T$$

$$x = [1 \ x_1 \ x_2 \ x_3 \ \dots \ x_n]^T$$

$$w' = [w_1 \ w_2 \ w_3 \ \dots \ w_n]^T$$

$$w = [b \ w_1 \ w_2 \ w_3 \ \dots \ w_n]^T$$

By doing the preceding manipulation, we've made the hyperplane in \mathbb{R}^n at a distance from the origin pass through the origin in the $\mathbb{R}^{(n+1)}$ vector space. The hyperplane is now only determined by its weight parameters vector $w \in \mathbb{R}^{(n+1) \times 1}$, and the rules for classification get simplified as follows:

- $w^T x = 0$ corresponds to the hyperplane, and all $x \in \mathbb{R}^{(n+1) \times 1}$ that lies on the hyperplane will satisfy this condition.
- $w^T x > 0$ corresponds to all points in the positive class. This means the classification is now solely determined by the angle between the vectors w and x . If input vector x makes an angle within -90 degrees to $+90$ degrees with the weight parameter vector w , then the output class is positive.
- $w^T x \leq 0$ corresponds to points in the negative class. The equality condition is treated differently in different classification algorithms. For Perceptrons, points on the hyperplanes are treated as belonging to the negative class.

Now we have everything we need to proceed with the Perceptron learning algorithm.

Let $x^{(i)} \in \mathbb{R}^{(n+1) \times 1} \forall i = \{1, 2, \dots, m\}$ represent the m input feature vectors and $y^{(i)} \in \{0, 1\} \forall i = \{1, 2, \dots, m\}$ the corresponding class label.

The Perceptron learning problem is as follows:

Step 1 – Start with a random set of weights $w \in \mathbb{R}^{(n+1) \times 1}$.

Step 2 – Evaluate the predicted class for a data point. For an input data point $x^{(i)}$ if $w^T x^{(i)} > 0$ then the predicted class $y_p^{(i)} = 1$, else $y_p^{(i)} = 0$. For the Perceptron classifier, points on the hyperplane are generally considered to belong to the negative class.

Step 3 – Update the weight vector w as follows:

If $y_p^{(i)} = 0$ and the actual class $y^{(i)} = 1$, update the weight vector as $w = w + x^{(i)}$.

If $y_p^{(i)} = 1$ and the actual class $y^{(i)} = 0$, update the weight vector as $w = w - x^{(i)}$.

If $y_p^{(i)} = y^{(i)}$, no updates are required to w .

Step 4 – Go to Step 2 and process the next data point.

Step 5 – Stop when all the data points have been correctly classified.

Perceptron will only be able to classify the two classes properly if there exists a feasible weight vector w that can linearly separate the two classes. In such cases, the Perceptron Convergence theorem guarantees convergence.

Geometrical Interpretation of Perceptron Learning

The geometrical interpretation of Perceptron learning sheds some light on the feasible weight vector w that represents a hyperplane separating the positive and the negative classes.

Cone of feasible w

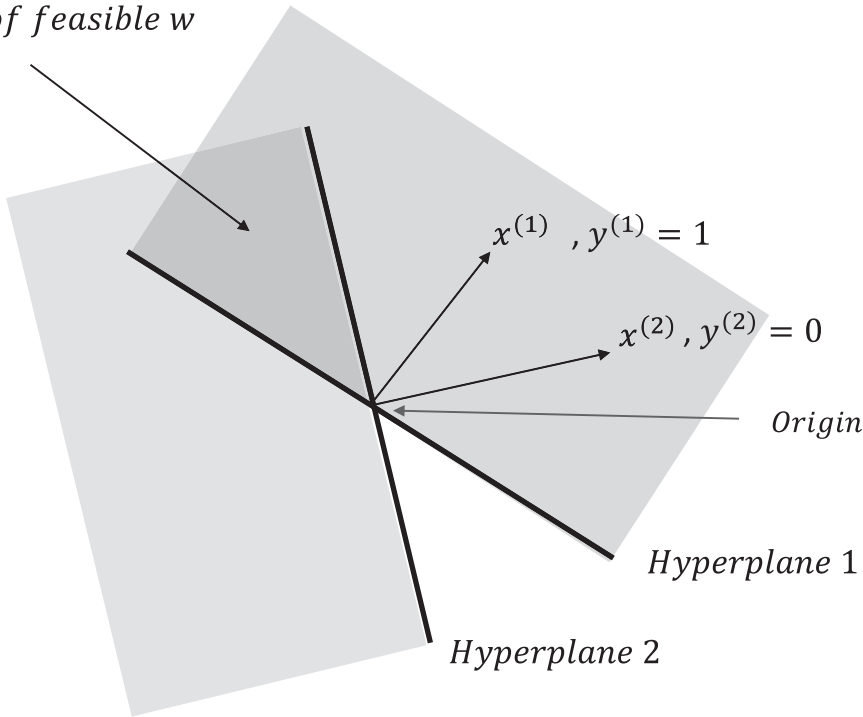

Vector Space of weights w

Figure 2-5. Hyperplanes in weight space and feasible set of weight vectors

Let us take two data points, $(x^{(1)}, y^{(1)})$ and $(x^{(2)}, y^{(2)})$, as illustrated in Figure 2-5. Further, let $x^{(i)} \in \mathbb{R}^{3 \times 1}$ include the constant feature of 1 for the intercept term. Also, let's take $y^{(1)} = 1$ and $y^{(2)} = 0$ (i.e., data point 1 belongs to the positive class while data point 2 belongs to the negative class).

In an input feature vector space, the weight vector determines the hyperplane. Along the same lines, we need to consider the individual input vectors as being representative of hyperplanes in the weight space to determine the feasible set of weight vectors for classifying the data points correctly.

In Figure 2-5, hyperplane 1 is determined by input vector $x^{(1)}$, which is perpendicular to hyperplane 1. Also, the hyperplane passes through the origin since the bias term has been consumed as a parameter within the weight vector w . For the first data point, $y^{(1)} = 1$. The prediction for the first data point would be correct if $w^T x^{(1)} > 0$. All the weight vectors w that are within an angle of -90 to $+90$ degrees from the input vector $x^{(1)}$ would satisfy the condition $w^T x^{(1)} > 0$. They form the feasible set of weight vectors for the first data point, as illustrated by the shaded region above hyperplane 1 in Figure 2-5.

Similarly, hyperplane 2 is determined by input vector $x^{(2)}$, which is perpendicular to hyperplane 2. For the second data point, $y^{(2)} = 0$. The prediction for the second data point would be correct if $w^T x^{(2)} \leq 0$. All the weight vectors w that are beyond an angle of -90 to $+90$ degrees from the input vector $x^{(2)}$ would satisfy the condition $w^T x^{(2)} \leq 0$. They form the feasible set of weight vectors for the second data point as illustrated by the shaded region below hyperplane 2 in Figure 2-5.

So, the set of weight vectors w that satisfy both the data points is the region of overlap between the two shaded regions. Any weight vector w in the region of overlap would be able to linearly separate the two data points by the hyperplanes they define in the input vector space.

Limitations of Perceptron Learning

The perceptron learning rule can only separate classes if they are linearly separable in the input space. Even the very basic XOR gate logic can't be implemented by the perceptron learning rule.

For the XOR logic below are the input and the corresponding output label or classes

- $x_1 = 1, x_2 = 0 \quad y = 1$
- $x_1 = 0, x_2 = 1 \quad y = 1$
- $x_1 = 1, x_2 = 1 \quad y = 0$
- $x_1 = 0, x_2 = 0 \quad y = 0$

Let us initialize the weight vector $w \rightarrow [0 \ 0 \ 0]^T$, where the first component of the weight vector corresponds to the bias term. Similarly, all the input vectors would have their first components as 1.

- For $x_1 = 1, x_2 = 0, y = 1$ the prediction is $w^T x = [0 \ 0 \ 0] \begin{bmatrix} 1 \\ 1 \\ 0 \end{bmatrix} = 0$. Since $w^T x = 0$, the data

point would be classified as 0, which doesn't match the actual class of 1. Hence, the updated weight vector as per the Perceptron rule should be

$$w \rightarrow w + x = \begin{bmatrix} 0 \\ 0 \\ 0 \end{bmatrix} + \begin{bmatrix} 1 \\ 1 \\ 0 \end{bmatrix} = \begin{bmatrix} 1 \\ 1 \\ 0 \end{bmatrix}.$$

- For $x_1 = 0, x_2 = 1, y = 1$ the prediction is $w^T x = [1 \ 1 \ 0] \begin{bmatrix} 1 \\ 0 \\ 1 \end{bmatrix} = 1$. Since $w^T x = 1 > 0$, the

data point would be correctly classified as 1. Hence, there would be no update to the

weight vector, and it stays at $\begin{bmatrix} 1 \\ 1 \\ 0 \end{bmatrix}$.

- For $x_1 = 1, x_2 = 1, y = 0$ the prediction is $w^T x = [1 \ 1 \ 0] \begin{bmatrix} 1 \\ 1 \\ 1 \end{bmatrix} = 2$. Since $w^T x = 2$, the data

point would be classified as 1, which doesn't match the actual class of 0. Hence, the

$$\text{updated weight vector should be } w \rightarrow w - x = \begin{bmatrix} 1 \\ 1 \\ 0 \end{bmatrix} - \begin{bmatrix} 1 \\ 1 \\ 1 \end{bmatrix} = \begin{bmatrix} 0 \\ 0 \\ -1 \end{bmatrix}.$$

- For $x_1 = 0, x_2 = 0, y = 0$ the prediction is $w^T x = [0 \ 0 \ -1] \begin{bmatrix} 1 \\ 0 \\ 0 \end{bmatrix} = 0$. Since $w^T x = 0$, the

data point would be correctly classified as 0. Hence, there would be no update to the weight vector w .

So, the weight vector after the first pass over the data points is $w = [0 \ 0 \ -1]^T$. Based on the updated weight vector w , let's evaluate how well the points have been classified.

- For data point 1, $w^T x = [0 \ 0 \ -1] \begin{bmatrix} 1 \\ 1 \\ 0 \end{bmatrix} = 0$, so it is wrongly classified as class 0.
- For data point 2, $w^T x = [0 \ 0 \ -1] \begin{bmatrix} 1 \\ 0 \\ 1 \end{bmatrix} = -1$, so it is wrongly classified as class 0.
- For data point 3, $w^T x = [0 \ 0 \ -1] \begin{bmatrix} 1 \\ 1 \\ 1 \end{bmatrix} = -1$, so it is correctly classified as class 0.
- For data point 4, $w^T x = [0 \ 0 \ -1] \begin{bmatrix} 1 \\ 0 \\ 0 \end{bmatrix} = 0$, so it is correctly classified as class 0.

Based on the preceding classifications, we see after the first iteration that the Perceptron algorithm managed to classify only the negative class correctly. If we were to apply the Perceptron learning rule over the data points again, the updates to the weight vector w in the second pass would be as follows:

- For data point 1, $w^T x = [0 \ 0 \ -1] \begin{bmatrix} 1 \\ 1 \\ 0 \end{bmatrix} = 0$, so it is wrongly classified as class 0. Hence, the updated weight as per the Perceptron rule is $w \rightarrow w + x = \begin{bmatrix} 0 \\ 0 \\ -1 \end{bmatrix} + \begin{bmatrix} 1 \\ 1 \\ 0 \end{bmatrix} = \begin{bmatrix} 1 \\ 1 \\ -1 \end{bmatrix}$.
- For data point 2, $w^T x = [1 \ 1 \ -1] \begin{bmatrix} 1 \\ 0 \\ 1 \end{bmatrix} = 0$, so it is wrongly classified as class 0. Hence, the updated weight as per the Perceptron rule is $w \rightarrow w + x = \begin{bmatrix} 1 \\ 1 \\ -1 \end{bmatrix} + \begin{bmatrix} 1 \\ 0 \\ 1 \end{bmatrix} = \begin{bmatrix} 2 \\ 1 \\ 0 \end{bmatrix}$.
- For data point 3, $w^T x = [2 \ 1 \ 0] \begin{bmatrix} 1 \\ 1 \\ 1 \end{bmatrix} = 3$, so it is wrongly classified as class 1. Hence, the updated weight as per perceptron rule is $w \rightarrow w - x = \begin{bmatrix} 2 \\ 1 \\ 0 \end{bmatrix} - \begin{bmatrix} 1 \\ 1 \\ 1 \end{bmatrix} = \begin{bmatrix} 1 \\ 0 \\ -1 \end{bmatrix}$.
- For data point 4, $w^T x = [1 \ 0 \ -1] \begin{bmatrix} 1 \\ 0 \\ 0 \end{bmatrix} = 1$, so it is wrongly classified as class 1. Hence, the updated weight as per perceptron rule is $w \rightarrow w - x = \begin{bmatrix} 1 \\ 0 \\ -1 \end{bmatrix} - \begin{bmatrix} 1 \\ 0 \\ 0 \end{bmatrix} = \begin{bmatrix} 0 \\ 0 \\ -1 \end{bmatrix}$.

The weight vector after the second pass is $[00-1]^T$, which is the same as the weight vector after the first pass. From the observations made during the first and second passes of Perceptron learning, it's clear that no matter how many passes we make over the data points we will always end up with the weight vector $[00-1]^T$. As we saw earlier, this weight vector can only classify the negative class correctly, and so we can safely infer without loss of generality that the Perceptron algorithm will always fail to model the XOR logic.

Need for Non-linearity

As we have seen, the Perceptron algorithm can only learn a linear decision boundary for classification and hence can't solve problems where non-linearity in the decision boundary is a need. Through the illustration of the XOR problem we saw that the Perceptron is incapable of linearly separating the two classes properly.

We need to have two hyperplanes to separate the two classes, as illustrated in Figure 2-6, and the one hyperplane learned through the Perceptron algorithm doesn't suffice to provide the required classification. In Figure 2-6, the data points in between the two hyperplane lines belong to the positive class while the other two data points belong to the negative class. Requiring two hyperplanes to separate two classes is the equivalent of having a non-linear classifier.

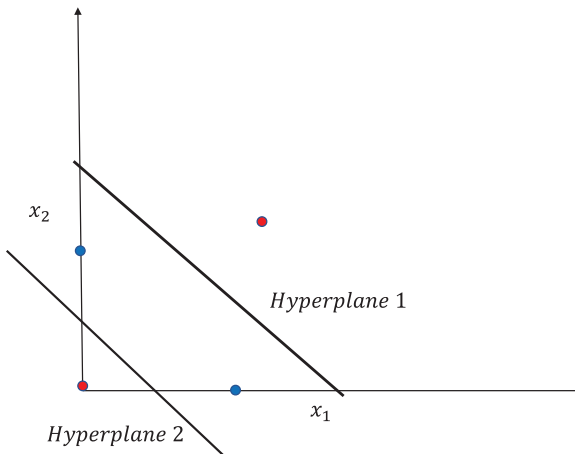

Figure 2-6. XOR problem with two hyperplanes to separate the two classes

A multi-layer Perceptron (MLP) can provide non-linear separation between classes by introducing non-linearity in the hidden layers. Do note that when a Perceptron outputs a 0 or 1 based on the total input received, the output is a non-linear function of its input. Everything said and done while learning the weights of the multi-layer Perceptron is not possible to achieve via the Perceptron learning rule.

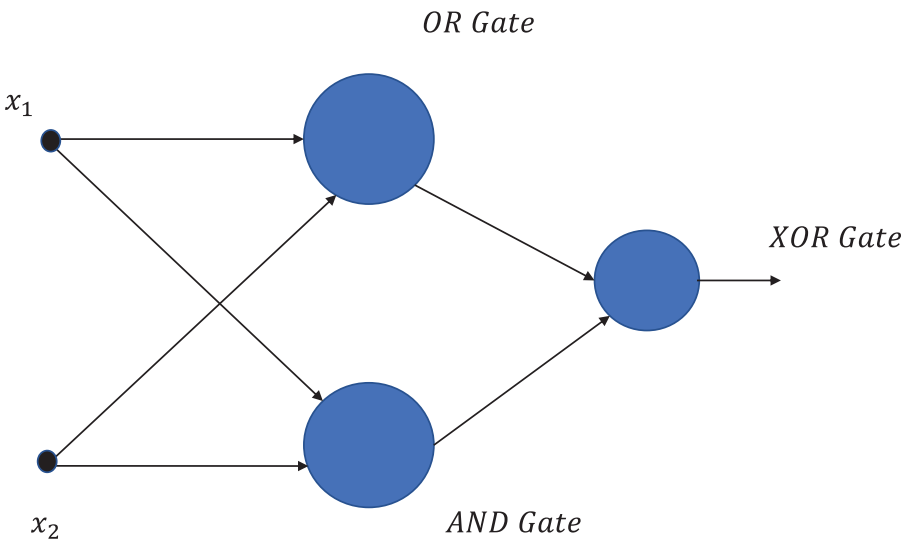

Figure 2-7. XOR logic implementation with multi-layer Perceptrons network

In Figure 2-7, the XOR logic has been implemented through a multi-layer Perceptrons network. If we have a hidden layer comprising two Perceptrons, with one capable of performing the OR logic while the other is capable of performing the AND logic, then the whole network would be able to implement the XOR logic. The Perceptrons for the OR and AND logic can be trained using the Perceptron learning rule. However, the network as a whole can't be trained through the Perceptron learning rule. If we look at the final input to the XOR gate, it will be a non-linear function of its input to produce a non-linear decision boundary.

Hidden Layer Perceptrons' Activation Function for Non-linearity

If we make the activation functions of the hidden layers linear, then the output of the final neuron would be linear, and hence we would not be able to learn any non-linear decision boundaries. To illustrate this, let's try to implement the XOR function through hidden layer units that have linear activation functions.

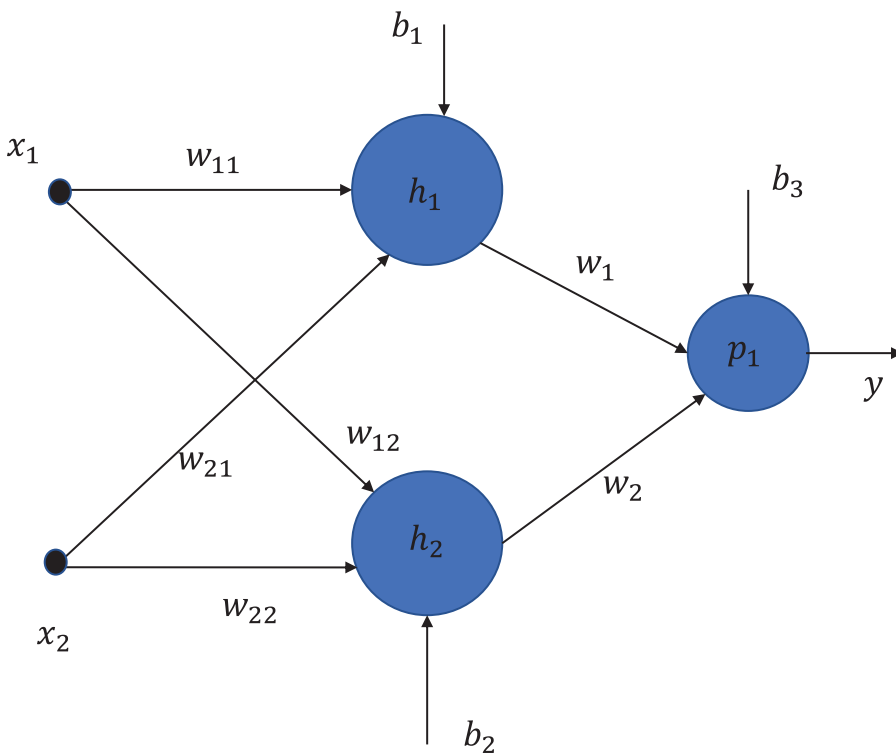

Figure 2-8. Linear output hidden layers in a two-layer Perceptrons network

Figure 2-8 shows a two-layer Perceptrons network with one hidden layer. The hidden layer consists of two neuron units. We look at the overall output of the network when the activations in the hidden units are linear:

$$\text{Output of the hidden unit } h_1 = w_{11}x_1 + w_{21}x_2 + b_1$$

$$\text{Output of the hidden unit } h_2 = w_{12}x_1 + w_{22}x_2 + b_2$$

$$\text{Output of the output unit } p_1 = w_1(w_{11}x_1 + w_{21}x_2 + b_1) + w_2(w_{12}x_1 + w_{22}x_2 + b_2) + b_3$$

$$= (w_1w_{11} + w_2w_{12})x_1 + (w_1w_{21} + w_2w_{22})x_2 + w_1b_1 + w_2b_2 + b_3$$

As deduced in the preceding lines, the final output of the network—i.e., the output of unit p_1 —is a linear function of its inputs, and thus the network can't produce a non-linear separation between classes.

If instead of a linear output being produced by the hidden layer we introduce an activation function represented as $f(x) = 1/(1 + e^{-x})$, then the output of the hidden unit $h_1 = 1/(1 + e^{-(w_{11}x_1 + w_{21}x_2 + b_1)})$.

$$\text{Similarly, the output of the hidden unit } h_2 = 1/(1 + e^{-(w_{12}x_1 + w_{22}x_2 + b_2)}) .$$

$$\text{The output of the output unit } p_1 = w_1/(1 + e^{-(w_{11}x_1 + w_{21}x_2 + b_1)}) + w_2/(1 + e^{-(w_{12}x_1 + w_{22}x_2 + b_2)}) + b_3 .$$

Clearly, the preceding output is non-linear in its inputs and hence can learn more complex non-linear decision boundaries rather than using a linear hyperplane for classification problems. The activation function for the hidden layers is called a sigmoid function, and we will discuss it in more detail in the subsequent sections.

Different Activation Functions for a Neuron/Perceptron

There are several activation functions for neural units, and their use varies with respect to the problem at hand and the topology of the neural network. In this section, we are going to discuss all the relevant activation functions that are used in today's artificial neural networks.

Linear Activation Function

In a linear neuron, the output is linearly dependent on its inputs. If the neuron receives three inputs x_1 , x_2 , and x_3 , then the output y of the linear neuron is given by $y = w_1x_1 + w_2x_2 + w_3x_3 + b$, where w_1 , w_2 , and w_3 are the synaptic weights for the input x_1 , x_2 , and x_3 respectively, and b is the bias at the neuron unit.

In vector notation, we can express the output $y = w^T x + b$.

If we take $w^T x + b = z$, then the output with respect to the net input z will be as represented in Figure 2-9.

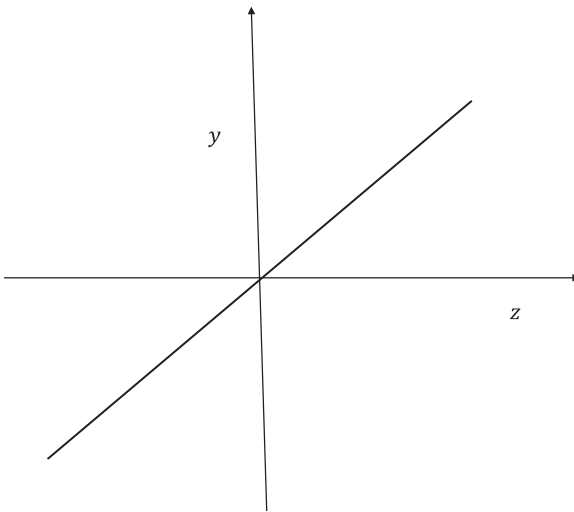

Figure 2-9. Linear output hidden layers in a two-layer Perceptrons network

Binary Threshold Activation Function

In a binary threshold neuron (see Figure 2-10), if the net input to the neuron exceeds a specified threshold then the neuron is activated; i.e., outputs 1 else it outputs 0. If the net linear input to the neuron is $z = w^T x + b$ and k is the threshold beyond which the neuron activates, then

$$y = 1 \quad \text{if } z > k$$

$$y = 0 \quad \text{if } z \leq k$$

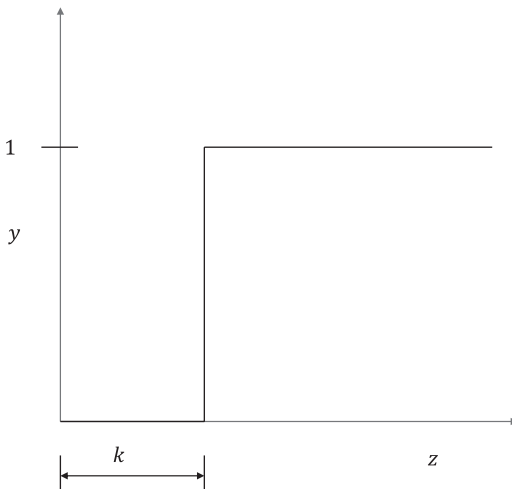

Figure 2-10. Binary threshold neuron

Generally, the binary threshold neuron is adjusted to activate at threshold 0 by adjusting the bias. The neuron is activated when $w^T x + b > k \Rightarrow w^T x + (b - k) > 0$.

Sigmoid Activation Function

The input-output relation for a sigmoid neuron is expressed as the following:

$$y = 1 / (1 + e^{-z})$$

where $z = w^T x + b$ is the net input to the *sigmoid* activation function.

- When the net input z to a sigmoid function is a positive large number $e^{-z} \rightarrow 0$ and so $y \rightarrow 1$.
- When the net input z to a sigmoid is a negative large number $e^{-z} \rightarrow \infty$ and so $y \rightarrow 0$.
- When the net input z to a sigmoid function is 0 then $e^{-z} = 1$ and so $y = \frac{1}{2}$.

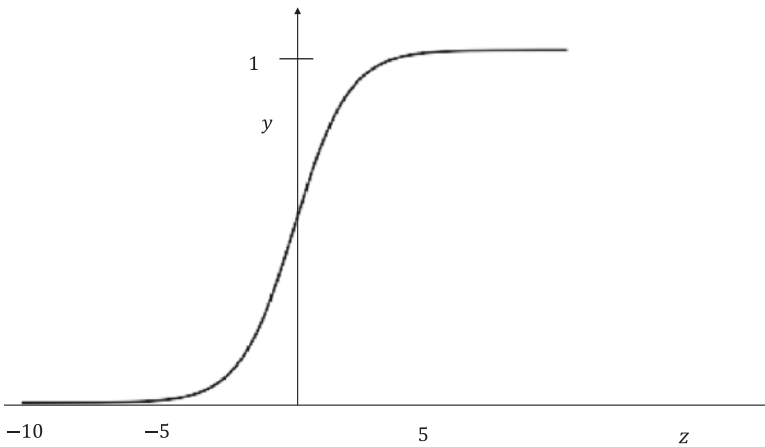

Figure 2-11. Sigmoid activation function

Figure 2-11 illustrates the input–output relationship of a sigmoid activation function. The output of a neuron that has a sigmoid activation function is very smooth and gives nice continuous derivatives, which works well when training a neural network. The output of a sigmoid activation function ranges between 0 and 1. Because of its capability to provide continuous values in the range of 0 to 1, the sigmoid function is generally used to output probability with respect to a given class for a binary classification. The sigmoid activation functions in the hidden layers introduce non-linearity so that the model can learn more complex features.

SoftMax Activation Function

The SoftMax activation function is a generalization of the sigmoid function and is best suited for multi-class classification problems. If there are k output classes and the weight vector for the i th class is $w^{(i)}$, then the predicted probability for the i th class given the input vector $x \in \mathbb{R}^{px1}$ is given by the following:

$$P(y_i = 1 / x) = \frac{e^{w^{(i)T}x + b^{(i)}}}{\sum_{j=1}^k e^{w^{(j)T}x + b^{(j)}}}$$

where $b^{(i)}$ is the bias term for each output unit of the SoftMax.

Let’s try to see the connection between a sigmoid function and a two-class SoftMax function.

Let’s say the two classes are y_1 and y_2 and the corresponding weight vectors for them are $w^{(1)}$ and $w^{(2)}$. Also, let the biases for them be $b^{(1)}$ and $b^{(2)}$ respectively. Let’s say the class corresponding to $y_1 = 1$ is the positive class.

$$P(y_1 = 1 / x) = \frac{e^{w^{(1)T}x + b^{(1)}}}{e^{w^{(1)T}x + b^{(1)}} + e^{w^{(2)T}x + b^{(2)}}}$$

$$= \frac{1}{1 + e^{-(w^{(1)} - w^{(2)})^T x - (b^{(1)} - b^{(2)})}}$$

We can see from the preceding expression that the probability of the positive class for a two-class SoftMax has the same expression as that of a sigmoid activation function, the only difference being that in the sigmoid we only use one set of weights, while in the two-class SoftMax there are two sets of weights. In sigmoid activation functions, we don't use different sets of weights for the two different classes, and the set of weight taken is generally the weight of the positive class with respect to the negative class. In SoftMax activation functions, we explicitly take different sets of weights for different classes.

The loss function for the SoftMax layer as represented by Figure 2-12 is called categorical cross entropy and is given by the following:

$$C = \sum_{i=1}^k -y_i \log P(y_i = 1/x)$$

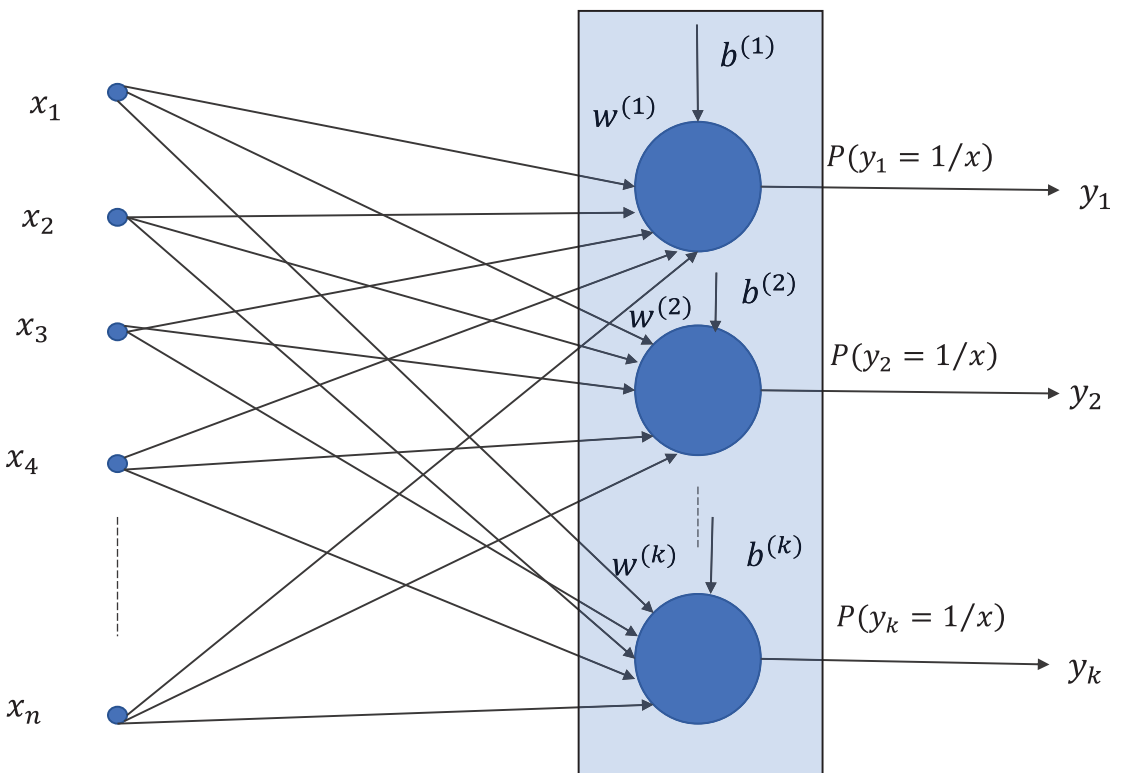

Figure 2-12. SoftMax activation function

Rectified Linear Unit(ReLU) Activation Function

In a rectified linear unit, as shown in Figure 2-13, the output equals the net input to the neuron if the overall input is greater than 0; however, if the overall input is less than or equal to 0 the neuron outputs a 0.

The output for a *ReLU* unit can be represented as follows:

$$y = \max(0, w^T x + b)$$

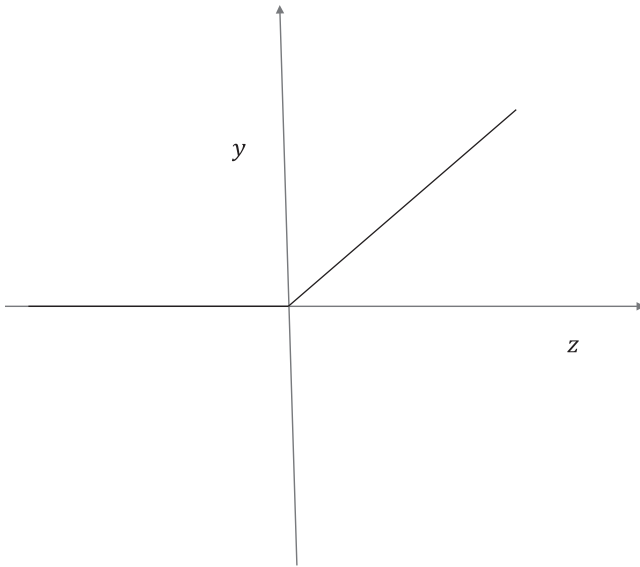

Figure 2-13. Rectified linear unit

The ReLU is one of the key elements that has revolutionized deep learning. They are easier to compute. ReLUs combine the best of both worlds—they have a constant gradient while the net input is positive and zero gradient elsewhere. If we take the sigmoid activation function, for instance, the gradient of the same is almost zero for very large positive and negative values, and hence the neural network might suffer from a vanishing-gradient problem. This constant gradient for positive net input ensures the gradient-descent algorithm doesn't stop learning because of a vanishing gradient. At the same time, the zero output for a non-positive net input renders non-linearity.

There are several versions of rectified linear unit activation functions such as parametric rectified linear unit (PReLU) and leaky rectified linear unit.

For a normal ReLU activation function, the output as well as the gradients are zero for non-positive input values, and so the training can stop because of the zero gradient. For the model to have a non-zero gradient even while the input is negative, PReLU can be useful. The input-output relationship for a PReLU activation function is given by the following:

$$y = \max(0, z) + \beta \min(0, z)$$

where $z = w^T x + b$ is the net input to the PReLU activation function and β is the parameter learned through training.

When β is set to -1 , then $y = |z|$ and the activation function is called absolute value ReLU. When β is set to some small positive value, typically around 0.01, then the activation function is called leaky ReLU.

Tanh Activation Function

The input-output relationship for a tanh activation function (see Figure 2-14) is expressed as

$$y = \frac{e^z - e^{-z}}{e^z + e^{-z}}$$

Where $z = w^T x + b$ is the net input to the tanh activation function.

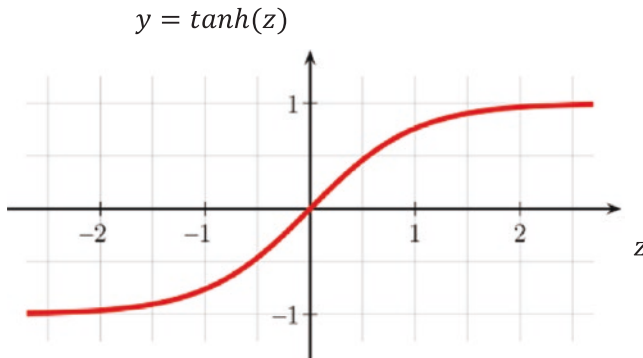

Figure 2-14. Tanh activation function

- When the net input z is a positive large number $e^{-z} \gg 0$ and so $y \gg 1$.
- When the net input z is a negative large number $e^z \gg 0$ and so $y \gg -1$.
- When the net input z is 0 then $e^{-z} = 1$ and so $y = 0$.

As we can see, tanh activation functions can output values between -1 and $+1$.

The sigmoid activation function saturates at around output 0. While training the network, if the outputs in the layer are close to zero the gradient vanishes and training stops. The tanh activation function saturates at -1 and +1 values for the output and has well-defined gradients at around the 0 value of the output. So, with tanh activation functions such vanishing-gradient problems can be avoided around output 0.

Learning Rule for Multi-Layer Perceptrons Network

In an earlier section, we saw that the Perceptron learning rule can only learn linear decision boundaries. Non-linear complex decision boundaries can be modeled through multi-layer Perceptrons; however, such a model cannot be learned through the Perceptron learning rule. Hence, one would need a different learning algorithm.

In the Perceptron learning rule, the goal is to keep updating the weights of the model till all the training data points have been correctly classified. If there is no such feasible weight vector that classifies all the points correctly, the algorithm doesn't converge. In such cases, the algorithm can be stopped by pre-defining the number of passes (iterations) to train or by defining a threshold for the number of correctly classified training data points after which to stop the training.

For multi-layer Perceptrons and for most of the deep-learning training networks, the best way to train the model is to compute a cost function based on the error of misclassification and then to minimize the cost function with respect to the parameters of the model. Since cost-based learning algorithms minimize the cost function, for binary classifications—generally the log-loss cost function—the negative of the log likelihood function is used. For reference, how the log-loss cost function is derived from maximum likelihood methods has been illustrated in Chapter 1 under “Logistic Regression.”

A multi-layer Perceptrons network would have hidden layers, and to learn non-linear decision boundaries the activation functions should be non-linear themselves, such as sigmoid, ReLu, tanh, and so forth. The output neuron for binary classification should have a sigmoid activation function in order to cater to the log-loss cost function and to output probability values for the classes.

Now, with the preceding considerations, let's try to solve the XOR function by building a log-loss cost function and then minimizing it with respect to the weight and bias parameters of the model. All the neurons in the network are taken to have sigmoid activation functions.

Referring to Figure 2-7, let the input and output at hidden unit h_1 be i_1 and z_1 respectively. Similarly, let the input and output at hidden unit h_2 be i_2 and z_2 respectively. Finally, let the input and output at output layer p_1 be i_3 and z_3 respectively.

$$i_1 = w_{11}x_1 + w_{21}x_2 + b_1$$

$$i_2 = w_{12}x_1 + w_{22}x_2 + b_2$$

$$z_1 = 1 / (1 + e^{-i_1})$$

$$z_2 = 1 / (1 + e^{-i_2})$$

$$i_3 = w_1z_1 + w_2z_2 + b_3$$

$$z_3 = 1 / (1 + e^{-i_3})$$

Considering the log-loss cost function, the total cost function for the XOR problem can be defined as follows:

$$C = \sum_{i=1}^4 -y^{(i)} \log z_3^{(i)} - (1 - y^{(i)}) \log(1 - z_3^{(i)})$$

If all the weights and biases put together can be thought of as a parameter vector θ , we can learn the model by minimizing the cost function $C(\theta)$:

$$\theta^* = \underset{\theta}{\text{Arg Min}} C(\theta)$$

For minima, the gradient of the cost function $C(\theta)$ with respect to θ (i.e., $\nabla C(\theta)$) should be zero. The minima can be reached through gradient-descent methods. The update rule for gradient descent is $\theta^{(t+1)} = \theta^{(t)} - \eta \nabla C(\theta^{(t)})$, where η is the learning rate and $\theta^{(t+1)}$ and $\theta^{(t)}$ are the parameter vectors at iterations $t+1$ and t respectively.

If we consider individual weight within the parameter vector, the gradient-descent update rule becomes the following:

$$w_k^{(t+1)} = w_k^{(t)} - \eta \frac{\partial C(w_k^{(t)})}{\partial w_k} \quad \forall w_k \in \theta$$

The gradient vector would not be as easy to compute as it would be in linear or logistic regression since in neural networks the weights follow a hierarchical order. However, the chain rule of derivatives provides for some simplification to methodically compute the partial derivatives with respect to the weights (including biases).

The method is called *backpropagation* and it provides simplification in gradient computation.

Backpropagation for Gradient Computation

Backpropagation is a useful method of propagating the error at the output layer backward so that the gradients at the preceding layers can be computed easily using the chain rule of derivatives.

Let us consider one training **example** and work through the backpropagation, taking the XOR network structure into account (see Figure 2-8). Let the input be $x = [x_1 \ x_2]^T$ and the corresponding class be y . So, the cost function for the single record becomes the following:

$$C = -y \log z_3 - (1 - y) \log(1 - z_3)$$

$$\frac{\partial C}{\partial w_1} = \frac{dC}{dz_3} \frac{dz_3}{di_3} \frac{\partial i_3}{\partial w_1}$$

$$\frac{dC}{dz_3} = \frac{(z_3 - y)}{z_3(1 - z_3)}$$

$$\text{Now } z_3 = 1/(1 + e^{-z_3})$$

$$\frac{dz_3}{di_3} = z_3(1 - z_3)$$

$$\frac{dC}{di_3} = \frac{dC}{dz_3} \frac{dz_3}{di_3} = \frac{(z_3 - y)}{z_3(1 - z_3)} z_3(1 - z_3) = (z_3 - y)$$

As we can see, the derivative of the cost function with respect to the net input in the final layer is nothing but the error in estimating the output ($z_3 - y$):

$$\frac{\partial i_3}{\partial w_1} = z_1$$

$$\frac{\partial C}{\partial w_1} = \frac{dC}{dz_3} \frac{dz_3}{di_3} \frac{\partial i_3}{\partial w_1} = (z_3 - y)z_1$$

Similarly,

$$\frac{\partial C}{\partial w_2} = \frac{dC}{dz_3} \frac{dz_3}{di_3} \frac{\partial i_3}{\partial w_2} = (z_3 - y)z_2$$

$$\frac{\partial C}{\partial b_3} = \frac{dC}{dz_3} \frac{dz_3}{di_3} \frac{\partial i_3}{\partial b_3} = (z_3 - y)$$

Now, let's compute the partial derivatives of the cost function with respect to the weights in the previous layer:

$$\frac{\partial C}{\partial z_1} = \frac{dC}{dz_3} \frac{dz_3}{di_3} \frac{\partial i_3}{\partial z_1} = (z_3 - y)w_1$$

$\frac{\partial C}{\partial z_1}$ can be treated as the error with respect to the output of the hidden layer unit h_1 . The error is propagated in proportion to the weight that is joining the output unit to the hidden layer unit. If there were multiple output units then $\frac{\partial C}{\partial z_1}$ would have a contribution from each of the output units. We will see this in detail in the next section.

Similarly,

$$\frac{\partial C}{\partial i_1} = \frac{dC}{dz_3} \frac{dz_3}{di_3} \frac{\partial i_3}{\partial z_1} \frac{dz_1}{di_1} = (z_3 - y)w_1z_1(1 - z_1)$$

$\frac{\partial C}{\partial i_1}$ can be considered the error with respect to the net input of the hidden layer unit h_1 . It can be computed by just multiplying the $z_1(1 - z_1)$ factor by $\frac{\partial C}{\partial z_1}$:

$$\frac{\partial C}{\partial w_{11}} = \frac{dC}{dz_3} \frac{dz_3}{di_3} \frac{di_3}{dz_1} \frac{dz_1}{di_1} \frac{\partial i_1}{\partial w_{11}} = (z_3 - y)w_1 z_1 (1 - z_1)x_1$$

$$\frac{\partial C}{\partial w_{21}} = \frac{dC}{dz_3} \frac{dz_3}{di_3} \frac{di_3}{dz_1} \frac{dz_1}{di_1} \frac{\partial i_1}{\partial w_{21}} = (z_3 - y)w_1 z_1 (1 - z_1)x_2$$

$$\frac{\partial C}{\partial b_1} = \frac{dC}{dz_3} \frac{dz_3}{di_3} \frac{di_3}{dz_1} \frac{dz_1}{di_1} \frac{\partial i_1}{\partial b_1} = (z_3 - y)w_1 z_1 (1 - z_1)$$

Once we have the partial derivative of the cost function with respect to the input in each neuron unit, we can compute the partial derivative of the cost function with respect to the weight contributing to the input—we just need to multiply the input coming through that weight.

Generalizing the Backpropagation Method for Gradient Computation

In this section, we try to generalize the backpropagation method through a more complicated network. We assume the final output layer is composed of three independent sigmoid output units, as depicted in Figure 2-15. Also, we assume that the network has a single record for ease of notation and for simplification in learning.

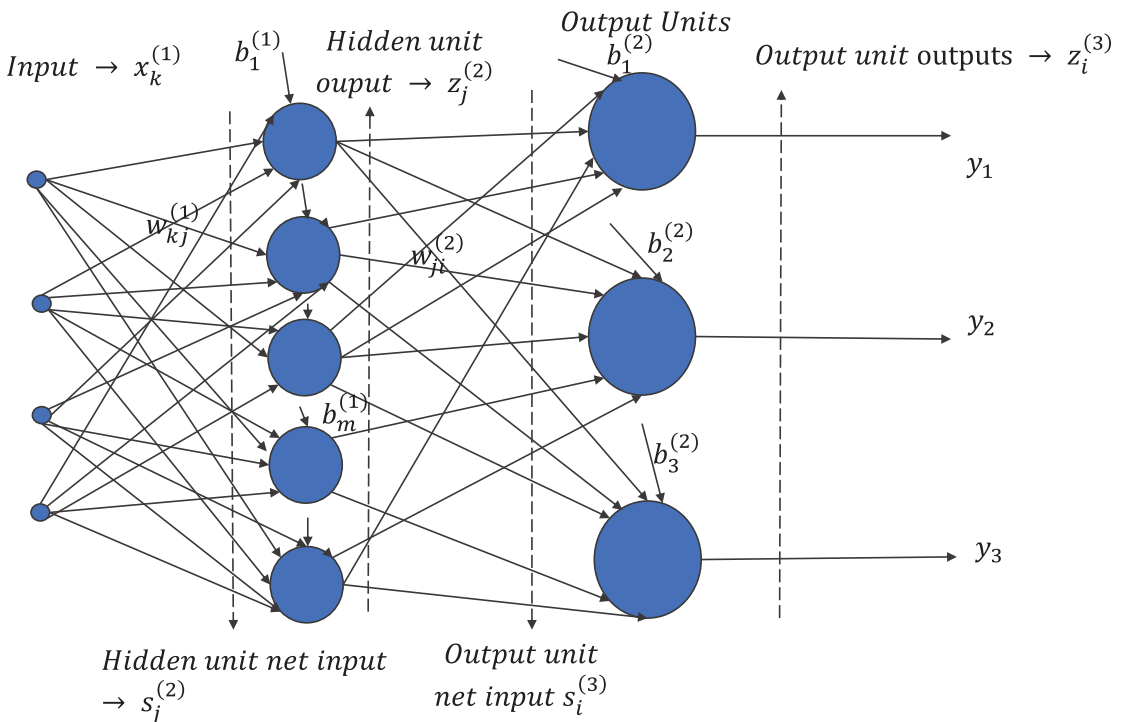

Figure 2-15. Network to illustrate backpropagation for independent sigmoid output layers

The cost function for a single input record is given by the following:

$$C = \sum_{i=1}^3 -y_i \log P(y_i = 1) - (1 - y_i) \log(1 - P(y_i = 1))$$

$$= \sum_{i=1}^3 -y_i \log z_i^{(3)} - (1 - y_i) \log(1 - z_i^{(3)})$$

In the preceding expression, $y_i \in \{0,1\}$, depending on whether the event specific to y_i is active or not.

$P(y_i = 1) = z_i^{(3)}$ denotes the predicted probability of the i th class.

Let's compute the partial derivative of the cost function with respect to the weight $w_{ji}^{(2)}$. The weight would only impact the output of the i th output unit of the network.

$$\frac{\partial C}{\partial w_{ji}^{(2)}} = \frac{\partial C}{\partial z_i^{(3)}} \frac{\partial z_i^{(3)}}{\partial s_i^{(3)}} \frac{\partial s_i^{(3)}}{\partial w_{ji}^{(2)}}$$

$$\frac{\partial C}{\partial z_i^{(3)}} = \frac{(z_i^{(3)} - y_i)}{z_i^{(3)}(1 - z_i^{(3)})}$$

$$P(y_i = 1) = z_i^{(3)} = 1 / (1 + e^{-s_i^{(3)}})$$

$$\frac{\partial z_i^{(3)}}{\partial s_i^{(3)}} = z_i^{(3)}(1 - z_i^{(3)})$$

$$\frac{\partial C}{\partial s_i^{(3)}} = \frac{\partial C}{\partial z_i^{(3)}} \frac{\partial z_i^{(3)}}{\partial s_i^{(3)}} = \frac{(z_i^{(3)} - y_i)}{z_i^{(3)}(1 - z_i^{(3)})} z_i^{(3)}(1 - z_i^{(3)}) = (z_i^{(3)} - y_i)$$

So, as before, the partial derivative of the cost function with respect to the net input for the i th output unit is $(z_i^{(3)} - y_i)$, which is nothing but the error in prediction at the i th output unit.

$$\frac{\partial s_i^{(3)}}{\partial w_{ji}^{(2)}} = z_j^{(2)}$$

Combining $\frac{\partial C}{\partial s_i^{(3)}}$ and $\frac{\partial s_i^{(3)}}{\partial w_{ji}^{(2)}}$, we get,

$$\frac{\partial C}{\partial w_{ji}^{(2)}} = (z_i^{(3)} - y_i) z_j^{(2)}$$

$$\frac{\partial C}{\partial b_i^{(2)}} = (z_i^{(3)} - y_i)$$

The preceding gives a generalized expression for partial derivatives of the cost function with respect to weights and biases in the last layer of the network. Next, let's compute the partial derivative of the weights and biases in the lower layers. Things get a little more involved but still follow a generalized trend. Let's compute the partial derivative of the cost function with respect to the weight $w_{kj}^{(1)}$. The weight would be impacted by the errors at all three output units. Basically, the error at the output of the j th unit in the hidden layer would have an error contribution from all output units, scaled by the weights connecting the output layers to the j th hidden unit. Let's compute the partial derivative just by the chain rule and see if it lives up to what we have proclaimed:

$$\frac{\partial C}{\partial w_{kj}^{(1)}} = \frac{\partial C}{\partial z_j^{(2)}} \frac{\partial z_j^{(2)}}{\partial s_j^{(2)}} \frac{\partial s_j^{(2)}}{\partial w_{kj}^{(1)}}$$

$$\frac{\partial s_j^{(2)}}{\partial w_{kj}^{(1)}} = z_k^{(1)}$$

$$\frac{\partial z_j^{(2)}}{\partial s_j^{(2)}} = z_j^{(2)} (1 - z_j^{(2)})$$

Now, $\frac{\partial C}{\partial z_j^{(2)}}$ is the tricky computation since $z_j^{(2)}$ influences all three output units:

$$\begin{aligned} \frac{\partial C}{\partial z_j^{(2)}} &= \sum_{i=1}^3 \frac{\partial C}{\partial z_i^{(3)}} \frac{\partial z_i^{(3)}}{\partial s_i^{(3)}} \frac{\partial s_i^{(3)}}{\partial z_j^{(2)}} \\ &= \sum_{i=1}^3 (z_i^{(3)} - y_i) w_{ji}^{(2)} \end{aligned}$$

Combining the expressions for $\frac{\partial s_j^{(2)}}{\partial w_{kj}^{(1)}}$, $\frac{\partial z_j^{(2)}}{\partial s_j^{(2)}}$ and $\frac{\partial C}{\partial z_j^{(2)}}$, we have

$$\frac{\partial C}{\partial w_{kj}^{(1)}} = \sum_{i=1}^3 (z_i^{(3)} - y_i) w_{ji}^{(2)} z_j^{(2)} (1 - z_j^{(2)}) x_k^{(1)}$$

In general, for a multi-layer neural network to compute the partial derivative of the cost function C with respect to a specific weight w contributing to the net input s in a neuron unit, we need to compute the partial derivative of the cost function with respect to the net input (i.e., $\frac{\partial C}{\partial s}$) and then multiply the input x associated with the weight w , as follows:

$$\frac{\partial C}{\partial w} = \frac{\partial C}{\partial s} \frac{\partial s}{\partial w} = \frac{\partial C}{\partial s} x$$

$\frac{\partial C}{\partial s}$ can be thought of as the error at the neural unit and can be computed iteratively by passing the

error at the output layer to the neural units in the lower layers. Another point to note is that an error in a higher-layer neural unit is distributed to the output of the preceding layer’s neural units in proportion to the weight connections between them. Also, the partial derivative of the cost function with respect to the net input to a sigmoid activation neuron $\frac{\partial C}{\partial s}$ can be computed from the partial derivative of the cost function with respect to the output z of a neuron (i.e., $\frac{\partial C}{\partial z}$) by multiplying $\frac{\partial C}{\partial z}$ by $z(1-z)$. For linear neurons, this multiplying factor becomes 1.

All these properties of neural networks make computing gradients easy. This is how a neural network learns in each iteration through backpropagation.

Each iteration is composed of a forward pass and a backward pass, or backpropagation. In the forward pass, the net input and output at each neuron unit in each layer are computed. Based on the predicted output and the actual target values, the error is computed in the output layers. The error is backpropagated by combining it with the neuron outputs computed in the forward pass and with existing weights. Through backpropagation the gradients get computed iteratively. Once the gradients are computed, the weights are updated by gradient-descent methods.

Please note that the deductions shown are valid for sigmoid activation functions. For other activation functions, while the approach remains the same, changes specific to the activation functions are required in the implementation.

The cost function for a SoftMax function is different from that for the independent multi-class classification.

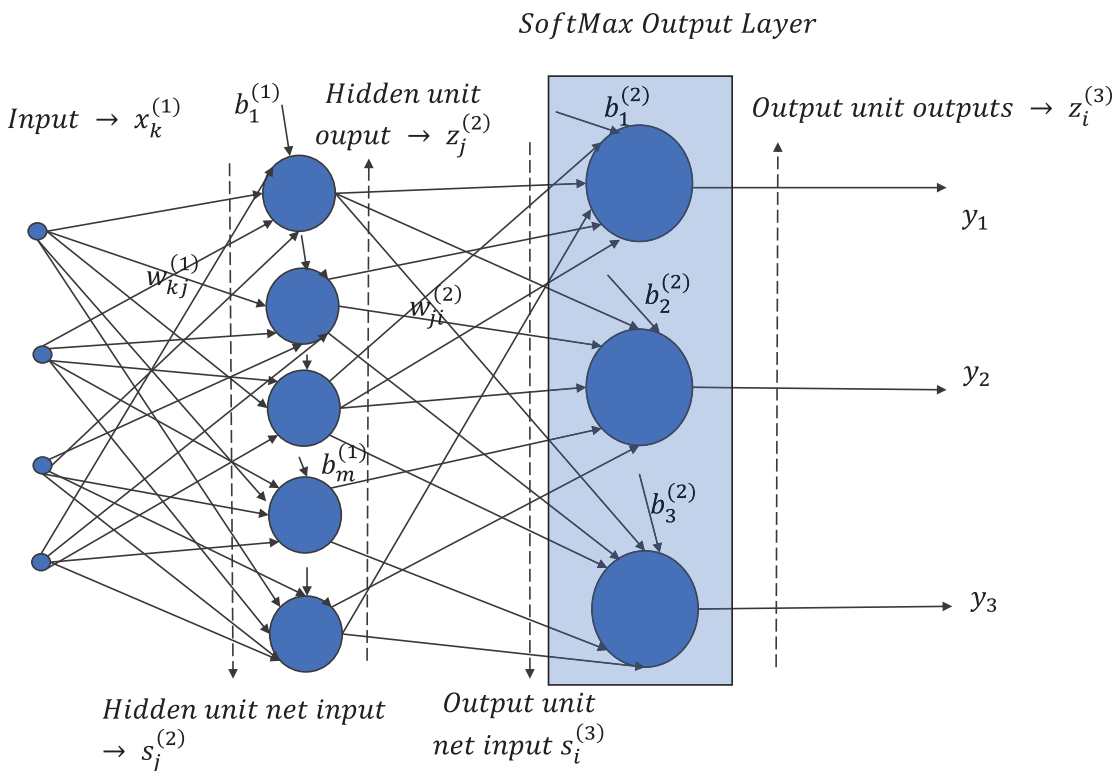

Figure 2-16. Network to illustrate backpropagation for Softmax output layer

The cross-entropy cost for the SoftMax activation layer in the network represented in Figure 2-16 is given by

$$C = \sum_{i=1}^3 -y_i \log P(y_i = 1) = \sum_{i=1}^3 -y_i \log z_i^{(3)}$$

Let's compute the partial derivative of the cost function with respect to the weight $w_{ji}^{(2)}$. Now, the weight would impact the net input $s_i^{(3)}$ to the i th SoftMax unit. However, unlike the independent binary activations in the earlier network, here all three SoftMax output units $z_k^{(3)} \forall k \in \{1, 2, 3\}$ would be influenced by $s_i^{(3)}$ since

$$z_k^{(3)} = \frac{e^{s_k^{(3)}}}{\sum_{l=1}^3 e^{s_l^{(3)}}} = \frac{e^{s_k^{(3)}}}{\sum_{l \neq i} e^{s_l^{(3)}} + e^{s_i^{(3)}}}$$

Hence, the derivative $\frac{\partial C}{\partial w_{ji}^{(2)}}$ can be written as follows:

$$\frac{\partial C}{\partial w_{ji}^{(2)}} = \frac{\partial C}{\partial s_i^{(3)}} \frac{\partial s_i^{(3)}}{\partial w_{ji}^{(2)}}$$

Now, as just stated, since $s_i^{(3)}$ influences all the outputs $z_k^{(3)}$ in the SoftMax layer,

$$\frac{\partial C}{\partial s_i^{(3)}} = \sum_{k=1}^3 \frac{\partial C}{\partial z_k^{(3)}} \frac{\partial z_k^{(3)}}{\partial s_i^{(3)}}$$

The individual components of the partial derivative are as follows:

$$\frac{\partial C}{\partial z_k^{(3)}} = \frac{-y_k}{z_k^{(3)}}$$

$$\text{For } k = i, \frac{\partial z_k^{(3)}}{\partial s_i^{(3)}} = z_i^{(3)} (1 - z_i^{(3)})$$

$$\text{For } k \neq i, \frac{\partial z_k^{(3)}}{\partial s_i^{(3)}} = -z_i^{(3)} z_k^{(3)}$$

$$\frac{\partial s_i^{(3)}}{\partial w_{ji}^{(2)}} = z_j^{(2)}$$

$$\frac{\partial C}{\partial s_i^{(3)}} = \sum_{k=1}^3 \frac{\partial C}{\partial z_k^{(3)}} \frac{\partial z_k^{(3)}}{\partial s_i^{(3)}} = \sum_{k=i} \frac{\partial C}{\partial z_k^{(3)}} \frac{\partial z_k^{(3)}}{\partial s_i^{(3)}} + \sum_{k \neq i} \frac{\partial C}{\partial z_k^{(3)}} \frac{\partial z_k^{(3)}}{\partial s_i^{(3)}}$$

$$\begin{aligned}
 &= \frac{-y_i}{z_i^{(3)}} z_i^{(3)} (1 - z_i^{(3)}) + \sum_{k \neq i} \frac{-y_k}{z_k^{(3)}} (-z_i^{(3)} z_k^{(3)}) \\
 &= -y_i (1 - z_i^{(3)}) + z_i^{(3)} \sum_{k \neq i} y_k \\
 &= -y_i + y_i z_i^{(3)} + z_i^{(3)} \sum_{k \neq i} y_k \\
 &= -y_i + z_i^{(3)} \sum_k y_k \\
 &= -y_i + z_i^{(3)} \text{ Since only one of the } y_k \text{ can be } 1 \therefore \sum_k y_k = 1 \\
 &= (z_i^{(3)} - y_i)
 \end{aligned}$$

As it turns out, the cost derivative with respect to the net input to the *i*th SoftMax unit is the error in predicting the output at the *i*th SoftMax output unit. Combining $\frac{\partial C}{\partial s_i^{(3)}}$ and $\frac{\partial s_i^{(3)}}{\partial w_{ji}^{(2)}}$, we get the following:

$$\frac{\partial C}{\partial w_{ji}^{(2)}} = \frac{\partial C}{\partial s_i^{(3)}} \frac{\partial s_i^{(3)}}{\partial w_{ji}^{(2)}} = (z_i^{(3)} - y_i) z_j^{(2)}$$

Similarly, for the bias term to the *i*th SoftMax output unit we have the following:

$$\frac{\partial C}{\partial b_i^{(2)}} = (z_i^{(3)} - y_i)$$

Computing the partial derivative of the cost function with respect to the weight $w_{kj}^{(1)}$ in the previous layer, i.e., $\frac{\partial C}{\partial w_{kj}^{(1)}}$, would have the same form as that in the case of a network with independent binary classes.

This is obvious since the networks only differ in terms of the output units' activation functions, and even then the expressions that we get for $\frac{\partial C}{\partial s_i^{(3)}}$ and $\frac{\partial s_i^{(3)}}{\partial w_{ji}^{(2)}}$ remain the same. As an exercise, interested readers can verify whether $\frac{\partial C}{\partial w_{kj}^{(1)}} = \sum_{i=1}^3 (z_i^{(3)} - y_i) w_{ji}^{(2)} z_j^{(2)} (1 - z_j^{(2)}) x_k^{(1)}$ still holds true.

Deep Learning Versus Traditional Methods

In this book, we will use TensorFlow from Google as the deep-learning library since it has several advantages. Before moving on to TensorFlow, let's look at some of the key advantages of deep learning and a few of its shortcomings if it is not used in the right place.

- Deep learning outperforms traditional machine-learning methods by a huge margin in several domains, especially in the fields of computer vision, speech recognition, natural language processing, and time series.

- With deep learning, more and more complex features can be learned as the layers in the deep-learning neural network increase. Because of this automatic feature-learning property, deep learning reduces the feature-engineering time, which is a time-consuming activity in traditional machine-learning approaches.
- Deep learning works best for unstructured data, and there is a plethora of unstructured data in the form of images, text, speech, sensor data, and so forth, which when analyzed would revolutionize different domains, such as health care, manufacturing, banking, aviation, e-commerce, and so on.

A few limitations of deep learning are as follows:

- Deep learning networks generally tend to have a lot of parameters, and for such implementations there should be a sufficiently large volume of data to train. If there are not enough data, deep-learning approaches will not work well since the model will suffer from overfitting.
- The complex features learned by the deep-learning network are often hard to interpret.
- Deep-learning networks require a lot of computational power to train because of the large number of weights in the model as well as the data volume.

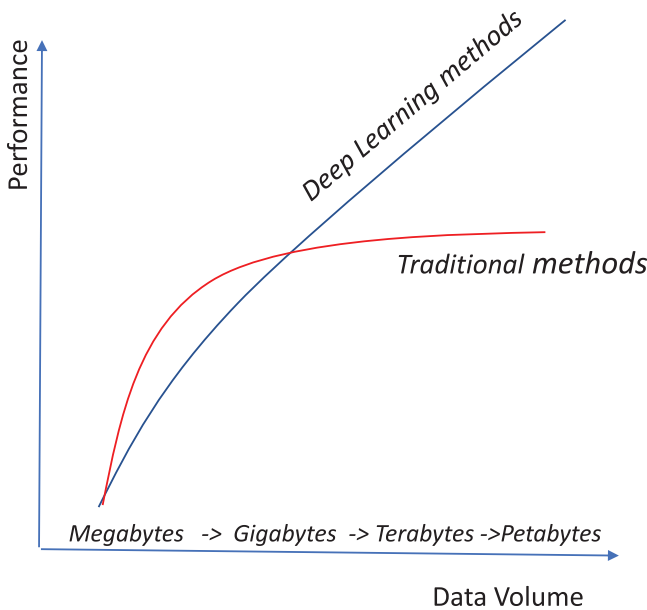

Figure 2-17. Performance comparison of traditional methods versus deep-learning methods

When the data volume is less, traditional methods tend to perform better than deep-learning ones. However, when the data volume is huge, the deep-learning method wins over traditional methods by a huge margin, which has been roughly depicted in Figure 2-17.

TensorFlow

TensorFlow from Google is an open source library that primarily focuses on deep learning. It uses computational data-flow graphs to represent complicated neural-network architecture. The nodes in the graph denote mathematical computations, also called ops (operations), whereas the edges denote the data tensors transferred between them. Also, the relevant gradients are stored at each node of the computational graph, and during backpropagation these are combined to get the gradients with respect to each weight. Tensors are multi-dimensional data arrays used by TensorFlow.

Common Deep-Learning Packages

The common deep-learning packages are as follows:

- **Torch** – A scientific computing framework with underlying C implementation and LuaJIT as the scripting language. Initial release of Torch was in 2002. Operating systems on which Torch works are Linux, Android, Mac OS X, and iOS. Reputed organizations such as Facebook AI Research and IBM use Torch. Torch can utilize GPU for fast computation.
- **Theano** – Is a deep-learning package in Python that is primarily used for computationally intensive research-oriented activities. It is tightly integrated with Numpy array and has efficient symbolic differentiators. It also provides transparent use of GPU for much faster computation.
- **Caffe** – Deep-learning framework developed by Berkeley AI Research ([BAIR](#)). Speed makes Caffe perfect for research experiments and industry deployment. Caffe implementation can use GPU very efficiently.
- **CuDNN** – CuDNN stands for CUDA Deep Neural Network library. It provides a library of primitives for GPU implementation of deep neural networks.
- **TensorFlow** – Open source deep-learning framework from Google inspired by Theano. TensorFlow is slowly becoming the preferred library for deep learning in research-oriented work as well as for production implementation. Also for distributed production implementation over the cloud, TensorFlow is becoming the go-to library.
- **MxNet** – Open source deep-learning framework that can scale to multiple GPUs and machines. Supported by major cloud providers such as AWS and Azure. Popular machine-learning library GraphLab has good deep-learning implementation using MxNet.
- **deeplearning4j** – Open source distributed deep-learning framework for Java virtual machines.

A few salient features of these deep-learning frameworks are as follows:

- Python is the high-level language of choice for TensorFlow and Theano, whereas Lua is the high-level language of choice for Torch. MxNet also has Python APIs.
- TensorFlow and Theano are very similar in nature. TensorFlow has better support for distributed systems. Theano is an academic project while TensorFlow is funded by Google.

- TensorFlow, Theano, MxNet, and Caffe all use automatic differentiators while Torch uses AutoGrad. Automatic differentiators are different from symbolic differentiation and numeric differentiation. Automatic differentiators are very efficient when used in neural networks because of the backpropagation method of learning that utilizes the chain rule of differentiation.
- For production implementation on the cloud, TensorFlow is on its way to becoming the go-to platform for applications targeting large distributed systems.

TensorFlow Installation

TensorFlow can be installed with ease in Linux-, Mac OS-, and Windows-based machines. It is always preferable to create separate environments for TensorFlow. One of the things to note is that TensorFlow installation in Windows requires your Python version to be greater than or equal to 3.5. Such limitations don't exist for Linux-based machines, or for Mac OS, for that matter. The details of installation for Windows-based machines are documented well on the official website for TensorFlow: https://www.tensorflow.org/install/install_windows. The installation links for Linux-based machines and Mac OS are:

https://www.tensorflow.org/install/install_linux

https://www.tensorflow.org/install/install_mac

TensorFlow Basics for Development

TensorFlow has its own format of commands to define and manipulate tensors. Also, TensorFlow executes the computational graphs within activated sessions. Listings 2-1 to 2-15 are a few of the basic TensorFlow commands used to define tensors and TensorFlow variables and to execute TensorFlow computational graphs within sessions.

Listing 2-1. Import TensorFlow and Numpy Library

```
import tensorflow as tf
import numpy as np
```

Listing 2-2. Activate a TensorFlow Interactive Session

```
tf.InteractiveSession()
```

Listing 2-3. Define Tensors

```
a = tf.zeros((2,2));
b = tf.ones((2,2))
```

Listing 2-4. Sum the Elements of the Matrix (2D Tensor) Across the Horizontal Axis

```
tf.reduce_sum(b,reduction_indices = 1).eval()

-- output --
array([ 2.,  2.], dtype=float32)
```

To run TensorFlow commands in interactive mode, the `Interactive Session()` command can be invoked as in Listing 2-2, and by using the `eval()` method the TensorFlow commands can be run under the activated interactive session as shown in Listing 2-4.

Listing 2-5. Check the Shape of the Tensor

```
a.get_shape()
-- output --
TensorShape([Dimension(2), Dimension(2)])
```

Listing 2-6. Reshape a Tensor

```
tf.reshape(a,(1,4)).eval()
-- output --
array([[ 0.,  0.,  0.,  0.]], dtype=float32)
```

Listing 2-7. Explicit Evaluation in TensorFlow and Difference with Numpy

```
ta = tf.zeros((2,2))
print(ta)
-- output --
Tensor("zeros_1:0", shape=(2, 2), dtype=float32)
print(ta.eval())
-- output --
[[ 0.  0.]
 [ 0.  0.]]
a = np.zeros((2,2))
print(a)
-- output --
[[ 0.  0.]
 [ 0.  0.]
```

Listing 2-8. Define TensorFlow Constants

```
a = tf.constant(1)
b = tf.constant(5)
c= a*b
```

Listing 2-9. TensorFlow Session for Execution of the Commands Through Run and Eval

```
with tf.Session() as sess:
    print(c.eval())
    print(sess.run(c))
```

-- output --

```
5
5
```

Listing 2-10a. Define TensorFlow Variables

```
w = tf.Variable(tf.ones(2,2),name='weights')
```

Listing 2-10b. Initialize the Variables After Invoking the Session

```
with tf.Session() as sess:
    sess.run(tf.global_variables_initializer())
    print(sess.run(w))
```

-- output --

```
[[ 1.  1.]
 [ 1.  1.]]
```

A TensorFlow session is generally activated through `tf.Session()` as shown in Listing 2-10b, and the computational graph operations(`ops`) are executed under the activated session.

Listing 2-11a. Define the TensorFlow Variable with Random Initial Values from Standard Normal Distribution

```
rw = tf.Variable(tf.random_normal((2,2)),name='random_weights')
```

Listing 2-11b. Invoke Session and Display the Initial State of the Variable

```
with tf.Session()as sess:
    sess.run(tf.global_variables_initializer())
    print(sess.run(rw))
```

-- output --

```
[[ 0.37590656 -0.11246648]
 [-0.61900514 -0.93398571]]
```

As shown in Listing 2-11b, the `run` method is used to execute the computational operations (`ops`) within an activated session, and `tf.global_variables_initializer()` when run initializes the TensorFlow variables defined. The random variable `rw` defined in 2-11a got initialized in Listing 2-11b.

Listing 2-12. TensorFlow Variable State Update

```

var_1 = tf.Variable(0,name='var_1')
add_op = tf.add(var_1,tf.constant(1))
upd_op = tf.assign(var_1,add_op)
with tf.Session() as sess:
    sess.run(tf.global_variables_initializer())
    for i in xrange(5):
        print(sess.run(upd_op))

```

-- output --

```

1
2
3
4
5

```

Listing 2-13. Display the TensorFlow Variable State

```

x = tf.constant(1)
y = tf.constant(5)
z = tf.constant(7)

mul_x_y = x*y
final_op = mul_x_y + z

with tf.Session() as sess:
    print(sess.run([mul_x_y,final_op]))

```

-- output --

```

5 12

```

Listing 2-14. Convert a Numpy Array to Tensor

```

a = np.ones((3,3))
b = tf.convert_to_tensor(a)
with tf.Session() as sess:
    print(sess.run(b))

```

-- output --

```

[[ 1.  1.  1.]
 [ 1.  1.  1.]
 [ 1.  1.  1.]]

```

Listing 2-15. Placeholders and Feed Dictionary

```

inp1 = tf.placeholder(tf.float32,shape=(1,2))
inp2 = tf.placeholder(tf.float32,shape=(2,1))
output = tf.matmul(inp1,inp2)
with tf.Session() as sess:

```

```
print(sess.run([output], feed_dict={inp1:[[1.,3.]], inp2:[[1],[3]]}))
-- output --
[array([[ 10.]], dtype=float32)]
```

A TensorFlow placeholder defines a variable, the data for which would be assigned at a later point in time. The data is generally passed to the placeholder through the `feed_dict` while running the ops involving the TensorFlow placeholder. This has been illustrated in Listing 2-15.

Gradient-Descent Optimization Methods from a Deep-Learning Perspective

Before we dive into the TensorFlow optimizers, it's important to understand a few key points regarding full-batch gradient descent and stochastic gradient descent, including their shortcomings, so that one can appreciate the need to come up with variants of these gradient-based optimizers.

Elliptical Contours

The cost function for a linear neuron with a least square error is quadratic. When the cost function is quadratic, the direction of the gradient resulting from the full-batch gradient-descent method gives the best direction for cost reduction in a linear sense, but it doesn't point to the minimum unless the different elliptical contours of the cost function are circles. In cases of long elliptical contours, the gradient components might be large in directions where less change is required and small in directions where more change is required to move to the minimum point.

As we can see in Figure 2-18, the gradient at *S* doesn't point to the direction of the minimum; i.e., point *M*. The problem with this condition is that if we take small steps by making the learning rate small then the gradient descent would take a while to converge, whereas if we were to use a big learning rate, the gradients would change direction rapidly in directions where the cost function had curvature, leading to oscillations. The cost function for a multi-layer neural network is not quadratic but rather is mostly a smooth function. Locally, such non-quadratic cost functions can be approximated by quadratic functions, and so the problems of gradient descent inherent to elliptical contours still prevail for non-quadratic cost functions.

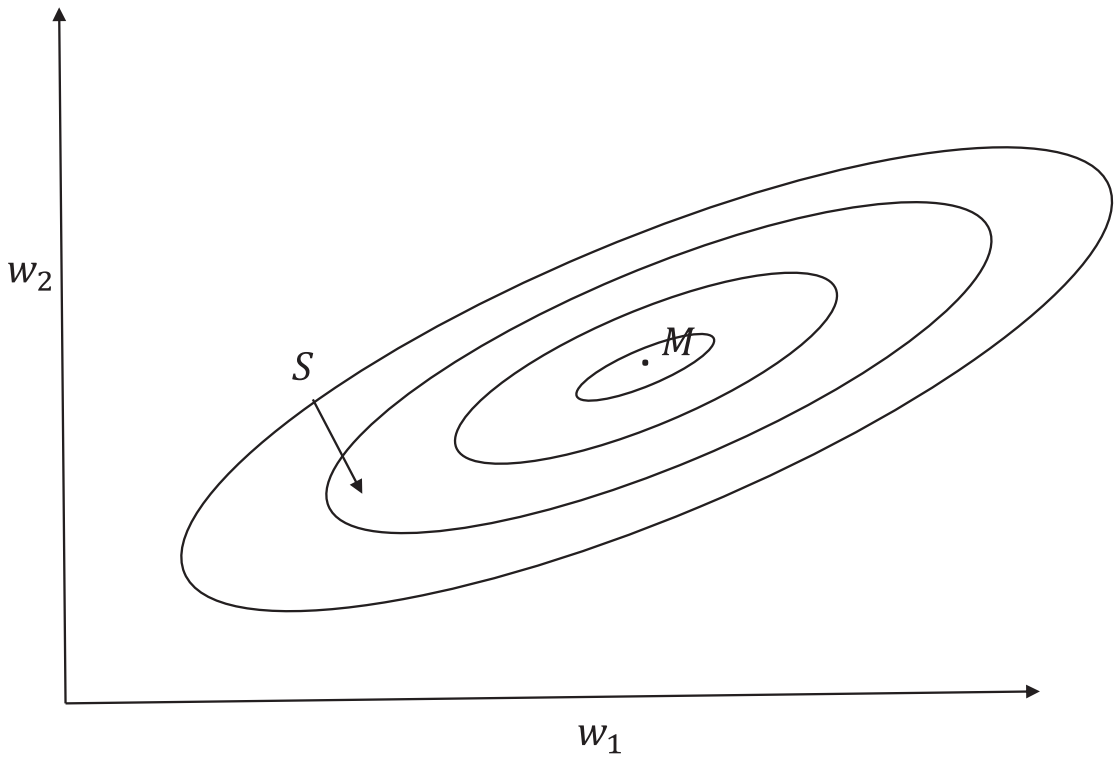

Figure 2-18. Contour plot for a quadratic cost function with elliptical contours

The best way to get around this problem is to take larger steps in those directions in which the gradients are small but consistent and take smaller steps in those directions that have big but inconsistent gradients. This can be achieved if, instead of having a fixed learning rate for all dimensions, we have a separate learning rate for each dimension.

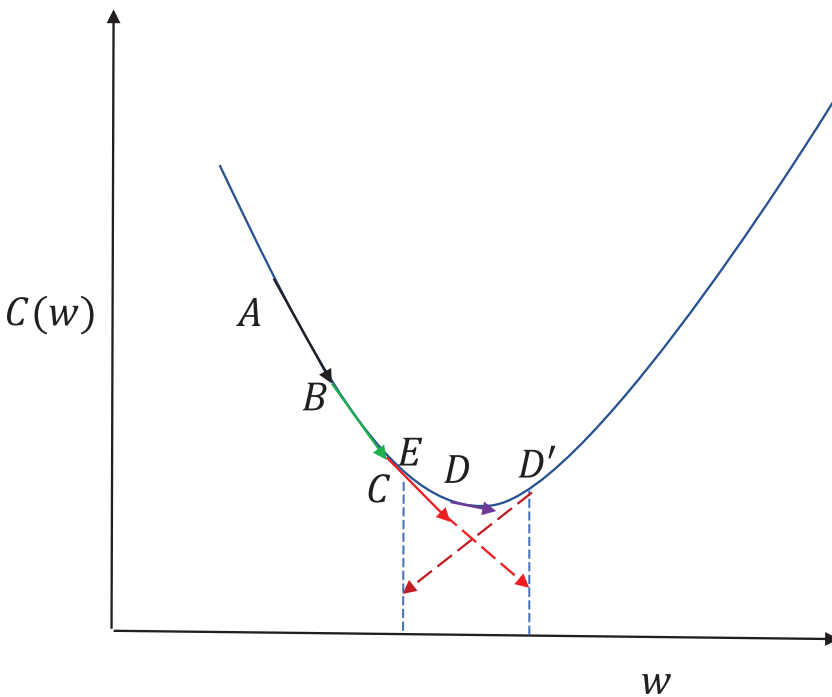

Figure 2-19. Gradient descent for a cost function with one variable

In Figure 2-19, the cost function between A and C is almost linear, and so gradient descent works well. However, from point C the curvature of the cost function takes over, and so the gradient at C is not able to keep up with the direction of the change in cost function. Based on the gradient, if we take a small learning rate at C we will end up at D, which is reasonable enough since it doesn't overshoot the point of minima. However, a larger step size at C will get us to D', which is not desirable, because it's on the other side of the minima. Again, a large step size at D' would get us to E, and if the learning rate is not reduced the algorithm tends to toggle between points on either side of the minima, leading to oscillations. When this happens, one way to stop it and achieve convergence is to look at the sign of the gradient $\frac{\partial C}{\partial w}$ or $\frac{dC}{dw}$ in successive

iterations, and if they have opposite signs, reduce the learning rate so that the oscillations are reduced. Similarly, if the successive gradients have the same sign then the learning rate can be increased accordingly. When the cost function is a function of multiple weights, the cost function might have curvatures in some dimensions of the weights while it might be linear along other dimensions. Hence, for multivariate cost functions, the partial derivative of the cost function with respect to each weight $\left(\frac{\partial C}{\partial w_i}\right)$ can be similarly analyzed to update the learning rate for each weight or dimension of the cost function.

Non-convexity of Cost Functions

The other big problem with neural networks is that the cost functions are mostly non-convex and so the gradient-descent method might get stuck at local minimum points, leading to a sub-optimal solution. The non-convex nature of the neural network is the result of the hidden layer units that have non-linear activation functions, such as sigmoid. Full-batch gradient descent uses the full dataset for the gradient computation. While this is good for convex cost surfaces, it has its own problems in cases of non-convex cost functions. For non-convex cost surfaces with full-batch gradients, the model is going to end up with the minima in its basin of attraction. If the initialized parameters are in the basin of attraction of a local minima that doesn't provide good generalization, a full-batch gradient would give a sub-optimal solution.

With stochastic gradient descent, the noisy gradients computed may force the model out of the basin of attraction of the bad local minima—one that doesn't provide good generalization—and place it in a more optimal region. Stochastic gradient descent with single data points produces very random and noisy gradients. Gradients with mini batches tend to produce much more stable estimates of gradients when compared to gradients of single data points, but they are still noisier than those produced by the full batches. Ideally, the mini-batch size should be carefully chosen such that the gradients are noisy enough to avoid or escape bad local minima points but stable enough to converge at global minima or a local minimum that provides good generalization.

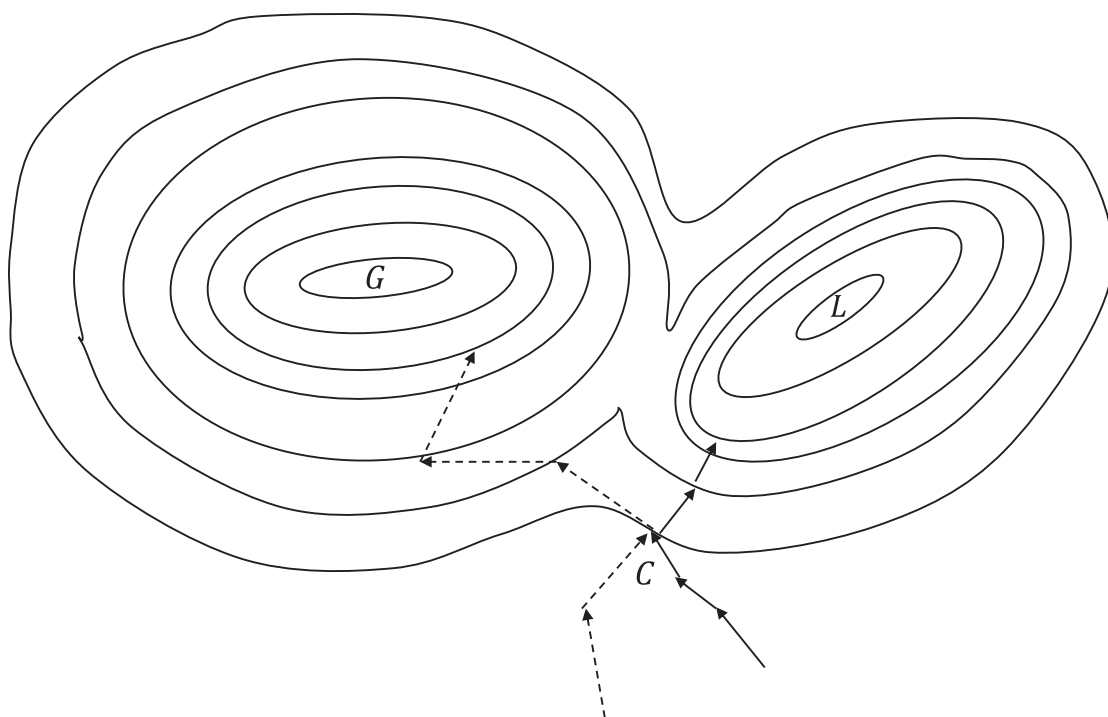

Figure 2-20. Contour plot showing basins of attraction for global and local minima and traversal of paths for gradient descent and stochastic gradient descent

In Figure 2-20, the dotted arrows correspond to the path taken by stochastic gradient descent (SGD), while the continuous arrows correspond to the path taken by full-batch gradient descent. Full-batch gradient descent computes the actual gradient at a point, and if it is in the basin of attraction of a poor local minimum, gradient descent almost surely ensures that the local minima L is reached. However, in the case of stochastic gradient descent, because the gradient is based on only portion of the data and not on the full batch, the gradient direction is only a rough estimate. Since the noisy rough estimate doesn't always point to the actual gradient at the point C , stochastic gradient descent may escape the basin of attraction of the local minima and fortunately land in the basin of a global minima. Stochastic gradient descent may escape the global minima basin of attraction too, but generally if the basin of attraction is large and the mini-batch size is carefully chosen so that the gradients it produces are moderately noisy, stochastic gradient descent is most likely to reach the global minima G (as in this case) or some other optimal minima that has a large basin of attraction. For non-convex optimization, there are other heuristics as well, such as momentum, which when adopted along with stochastic gradient descent increases the chances of the SGD's avoiding shallow local minima. Momentum generally keeps track of the previous gradients through the velocity component. So, if the gradients are steadily pointing toward a good local minimum that has a large basin of attraction, the velocity component would be high in the direction of the good local minimum. If the new gradient is noisy and points toward a bad local minimum, the velocity component would provide momentum to continue in the same direction and not get influenced by the new gradient too much.

Saddle Points in the High-Dimensional Cost Functions

Another impediment to optimizing non-convex cost functions is the presence of saddle points. The number of saddle points increases exponentially with the dimensionality increase of the parameter space of a cost function. Saddle points are stationary points (i.e., points where the gradient is zero) but are neither a local minimum nor a local maximum point. Since the saddle points are associated with a long plateau of points with the same cost as that of the saddle point, the gradient in the plateau region is either zero or very close to zero. Because of this near-zero gradient in all directions, gradient-based optimizers have a hard time coming out of these saddle points. Mathematically, to determine whether a point is a saddle point the Eigen values of the Hessian matrix of the cost function must be computed at the given point. If there are both positive and negative Eigen values, then it is a saddle point. Just to refresh our memory of local and global minima tests, if all the Eigen values of the Hessian matrix are positive at a stationary point then the point is a global minimum, whereas if all the Eigen values of the Hessian matrix are negative at the stationary point then the point is a global maximum. The Eigen vectors of the Hessian matrix for a cost function give the direction of change in the curvature of the cost function, whereas the Eigen values denote the magnitude of the curvature changes along those directions. Also, for cost functions with continuous second derivatives, the Hessian matrix is symmetrical and hence would always produce an orthogonal set of Eigen vectors, thus giving mutually orthogonal directions for cost curvature changes. If in all such directions given by Eigen vectors the values of the curvature changes (Eigen values) are positive, then the point must be a local minimum, whereas if all the values of curvature changes are negative, then the point is a local maximum. This generalization works for cost functions with any input dimensionality, whereas the determinant rules for determining extremum points varies with the dimensionality of the input to the cost function. Coming back to saddle points, since the Eigen values are positive for some directions but negative for other directions, the curvature of the cost function increases in the direction of positive Eigen values while decreasing in the direction of Eigen vectors with negative co-efficients. This nature of the cost surface around a saddle point generally leads to a region of long plateau with a near-to-zero gradient and makes it tough for gradient-descent methods to escape the plateau of this low gradient. The point $(0, 0)$ is a saddle point for the function $f(x,y) = x^2 - y^2$ as we can see from the following evaluation below:

$$\nabla f(x,y) = 0 \Rightarrow \frac{\partial f}{\partial x} = 0 \text{ and } \frac{\partial f}{\partial y} = 0$$

$$\frac{\partial f}{\partial x} = 2x = 0 \Rightarrow x = 0$$

$$\frac{\partial f}{\partial y} = -2y = 0 \Rightarrow y = 0$$

So, $(x,y)=(0,0)$ is a stationary point. The next thing to do is to compute the Hessian matrix and evaluate its Eigen values at $(x,y)=(0,0)$. The Hessian matrix $Hf(x,y)$ is as follows:

$$Hf(x,y) = \begin{bmatrix} \frac{\partial^2 f}{\partial x^2} & \frac{\partial^2 f}{\partial x \partial y} \\ \frac{\partial^2 f}{\partial x \partial y} & \frac{\partial^2 f}{\partial y^2} \end{bmatrix} = \begin{bmatrix} 2 & 0 \\ 0 & -2 \end{bmatrix}$$

So, the Hessian $Hf(x,y)$ at all points including $(x,y)=(0,0)$ is $\begin{bmatrix} 2 & 0 \\ 0 & -2 \end{bmatrix}$.

The two eigen values of the $Hf(x,y)$ are 2 and -2, corresponding to the Eigen vectors $\begin{bmatrix} 1 \\ 0 \end{bmatrix}$ and $\begin{bmatrix} 0 \\ 1 \end{bmatrix}$,

which are nothing but the directions along the X and Y axes. Since one Eigen value is positive and the other negative, $(x,y)=(0,0)$ is a saddle point.

The non-convex function $f(x,y) = x^2 - y^2$ is plotted in Figure 2-21, where S is the saddle point at $x,y=(0,0)$

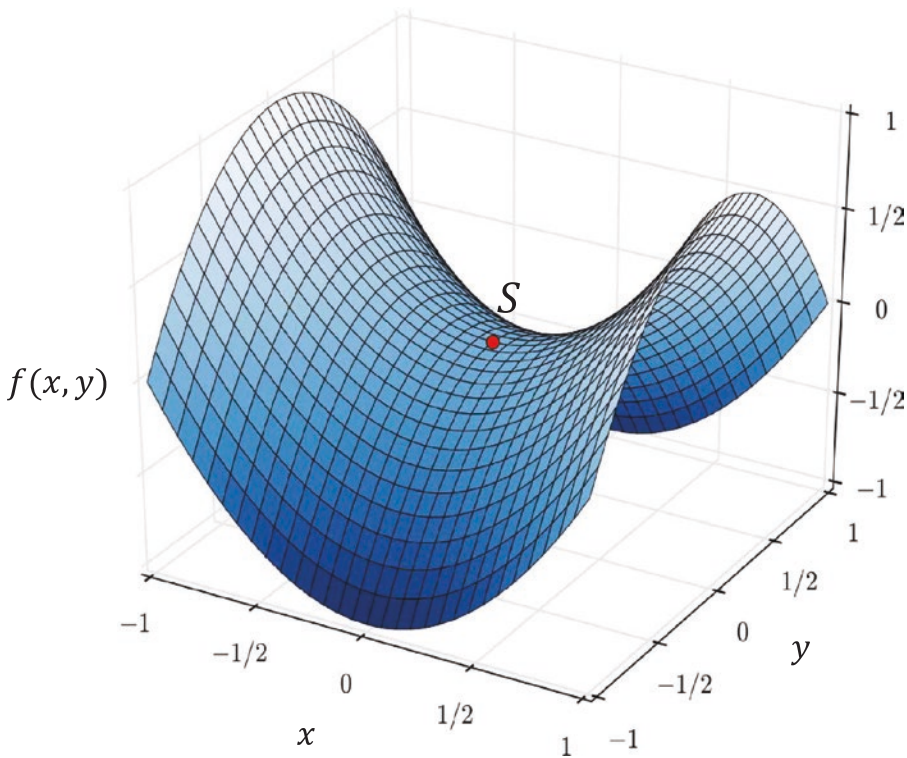

Figure 2-21. Plot of $f(x,y)=x^2-y^2$

Learning Rate in Mini-batch Approach to Stochastic Gradient Descent

When there is high redundancy in the dataset, the gradient computed on a mini-batch of data points is almost the same as the gradient computed on the whole dataset, provided the mini batch is a good representation of the entire dataset. In such cases, computing the gradient on the whole dataset can be avoided, and instead the gradient on the mini batch of data points can be used as the approximate gradient for the whole dataset. This is the mini-batch approach to gradient descent, which is also called mini-batch stochastic gradient descent. When, instead of using a mini batch, the gradients are approximated by one data point, it is called online learning or stochastic gradient descent. However, it is always better to use the mini-batch version of stochastic gradient descent over online learning since the gradients for the mini-batch method are less noisy compared to the online mode of learning. Learning rate plays a vital role in the convergence of mini-batch stochastic gradient descent. The following approach tends to provide good convergence:

- Start with an initial learning rate.
- Increase the learning rate if the error reduces.
- Decrease the learning rate if the error increases.
- Stop the learning process if the error ceases to reduce.

As we will see in the next section, the different optimizers adopt an adaptive learning-rate approach in their implementations.

Optimizers in TensorFlow

TensorFlow has a rich inventory of optimizers for optimizing cost functions. The optimizers are all gradient based, along with some special optimizers to handle local minima problems. Since we dealt with the most common gradient-based optimizers used in machine learning and deep learning in the first chapter, here we will stress the customizations added in TensorFlow to the base algorithms.

GradientDescentOptimizer

`GradientDescentOptimizer` implements the fundamental full-batch gradient-descent algorithm and takes the learning rate as an input. The gradient-descent algorithm will not loop over the iterations automatically, so such logic must be specified in the implementation, as we will see later.

The most important method is the `minimize` method in which one needs to specify the cost function to minimize (denoted by `loss`) and the variable list (denoted by `var_list`) with respect to which the cost function must be minimized. The `minimize` method internally invokes the `compute_gradients()` and `apply_gradients()` methods. Declaring the variable list is optional, and if not specified the gradients are computed with respect to the variables defined as TensorFlow variables (i.e., ones declared as `tensorflow.Variable()`).

Usage

```
train_op = tf.train.GradientDescentOptimizer(learning_rate).minimize(cost)
```

where `learning_rate` is the constant learning rate and `cost` is the cost function that needs to be minimized through gradient descent. The cost function is minimized with respect to the TensorFlow variables associated with the cost function.

AdagradOptimizer

`AdagradOptimizer` is a first-order optimizer like gradient descent but with some modifications. Instead of having a global learning rate, the learning rate is normalized for each dimension on which the cost function is dependent. The learning rate in each iteration is the global learning rate divided by the l^2 norm of the prior gradients up to the current iteration for each dimension.

If we have a cost function $C(\theta)$ where $\theta = [\theta_1 \theta_2 \theta_3 \dots \theta_n]^T \in \mathbb{R}^{n \times 1}$, then the update rule for θ_i is as follows:

$$\theta_i^{(t+1)} = \theta_i^{(t)} - \frac{\eta}{\sqrt{\sum_{\tau=1}^t \theta_i^{(\tau)2} + \epsilon}} \frac{\partial C^{(t)}}{\partial \theta_i}$$

Where η is the learning rate and $\theta_i^{(t)}$ and $\theta_i^{(t+1)}$ are the values for the i th parameter at iterations t and $t + 1$ respectively.

In a matrix format, the parameter update for the vector θ can be represented by the following:

$$\theta^{(t+1)} = \theta^{(t)} - \eta G_{(t)}^{-1} \nabla C(\theta^{(t)})$$

where $G_{(t)}$ is the diagonal matrix containing the L^2 norm of the past gradients till iteration t for each dimension. The matrix $G_{(t)}$ would be of the following form:

$$G_{(t)} = \begin{bmatrix} \sqrt{\sum_{\tau=1}^t \theta_1^{(\tau)2} + \epsilon} & \dots & 0 \\ \vdots & \sqrt{\sum_{\tau=1}^t \theta_i^{(\tau)2} + \epsilon} & \vdots \\ 0 & \dots & \sqrt{\sum_{\tau=1}^t \theta_n^{(\tau)2} + \epsilon} \end{bmatrix}$$

Sometimes sparse features that don't show up much in the data can be very useful to an optimization problem. However, with basic gradient descent or stochastic gradient descent the learning rate gives equal importance to all the features in each iteration. Since the learning rate is same, the overall contribution of non-sparse features would be much more than that of sparse features. Hence, we end up losing critical information from the sparse features. With Adagrad, each parameter is updated with a different learning rate. The sparser the feature is, the higher its parameter update would be in an iteration. This is because for

sparse features the quantity $\sqrt{\sum_{\tau=1}^t \theta_i^{(\tau)2} + \epsilon}$ would be less and hence the overall learning rate would be high.

This is a good optimizer to use in applications with natural language processing and image processing where the data is sparse.

Usage

```
train_op = tf.train.AdagradOptimizer.(learning_rate=0.001, initial_accumulator_value=0.1)
```

where `learning_rate` represents η and `initial_accumulator_value` represents the initial non-zero normalizing factor for each weight.

RMSprop

RMSprop is the mini-batch version of the resilient backpropagation (Rprop) optimization technique that works best for full-batch learning. Rprop solves the issue of gradients' not pointing to the minimum in cases where the cost function contours are elliptical. As we discussed earlier, in such cases, instead of a global learning rule a separate adaptive update rule for each weight would lead to better convergence. The special thing with Rprop is that it doesn't use the magnitude of the gradients of the weight but only the signs in determining how to update each weight. The following is the logic by which Rprop works:

- Start with the same magnitude of weight update for all weights; i.e., $\Delta_{ij}^{(t-0)} = \Delta_{ij}^{(0)} = \Delta$.

Also, set the maximum and minimum allowable weight updates to Δ_{max} and Δ_{min} respectively.

- At each iteration, check the sign of both the previous and the current gradient components; i.e., the partial derivatives of the cost function with respect to the different weights.
- If the signs of the current and previous gradient components for a weight connection are the same—i.e., $\text{sign}\left(\frac{\partial C^{(t)}}{\partial w_{ij}} \frac{\partial C^{(t-1)}}{\partial w_{ij}}\right) = +ve$ —then increase the learning by a factor $\eta_+ = 1.2$. The update rule becomes

$$\Delta_{ij}^{(t+1)} = \min\left(\eta_+ \Delta_{ij}^{(t)}, \Delta_{\max}\right)$$

$$w_{ij}^{(t+1)} = w_{ij}^{(t)} - \text{sign}\left(\frac{\partial C^{(t)}}{\partial w_{ij}}\right) \cdot \Delta_{ij}^{(t+1)}$$

- If the signs of the current and previous gradient components for a dimension are different—i.e., $\text{sign}\left(\frac{\partial C^{(t)}}{\partial w_{ij}} \frac{\partial C^{(t-1)}}{\partial w_{ij}}\right) = -ve$ —then reduce the learning rate by a factor $\eta_- = 0.5$. The update rule becomes

$$\Delta_{ij}^{(t+1)} = \max\left(\eta_- \Delta_{ij}^{(t)}, \Delta_{\min}\right)$$

$$w_{ij}^{(t+1)} = w_{ij}^{(t)} - \text{sign}\left(\frac{\partial C^{(t)}}{\partial w_{ij}}\right) \cdot \Delta_{ij}^{(t+1)}$$

- If $\frac{\partial C^{(t)}}{\partial w_{ij}} \frac{\partial C^{(t-1)}}{\partial w_{ij}} = 0$, the update rule is as follows:

$$\Delta_{ij}^{(t+1)} = \Delta_{ij}^{(t)}$$

$$w_{ij}^{(t+1)} = w_{ij}^{(t)} - \text{sign}\left(\frac{\partial C^{(t)}}{\partial w_{ij}}\right) \cdot \Delta_{ij}^{(t+1)}$$

The dimensions along which the gradients are not changing sign at a specific interval during gradient descent are the dimensions along which the weight changes are consistent. Hence, increasing the learning rate would lead to faster convergence of those weights to their final value.

The dimensions along which the gradients are changing sign indicate that along those dimensions the weight changes are inconsistent, and so by decreasing the learning rate one would avoid oscillations and better catch up with the curvatures. For a convex function, gradient sign change generally occurs when there is curvature in the cost function surface and the learning rate is set high. Since the gradient doesn't have the curvature information, a large learning rate takes the updated parameter value beyond the minima point, and the phenomena keeps on repeating on either side of the minima point.

Rprop works well with full batches but doesn't do well when stochastic gradient descent is involved. When the learning rate is very small, gradients from different mini batches average out in cases of stochastic gradient descent. If through stochastic gradient descent for a cost function the gradients for a weight are +0.2 each for nine mini-batches and -0.18 for the tenth mini batch when the learning rate is small, then the effective gradient effect for stochastic gradient descent is almost zero and the weight remains almost at the same position, which is the desired outcome.

However, with Rprop the learning rate will increase about nine times and decrease only once, and hence the effective weight would be much larger than zero. This is undesirable.

To combine the qualities of Rprop's adaptive learning rule for each weight with the efficiency of stochastic gradient descent, RMSprop came into the picture. In Rprop we don't use the magnitude but rather just the sign of the gradient for each weight. The sign of the gradient for each weight can be thought of as dividing the gradient for the weight by its magnitude. The problem with stochastic gradient descent is that with each mini batch the cost function keeps on changing and hence so do the gradients. So, the idea is to get a magnitude of gradient for a weight that would not fluctuate much over nearby mini batches. What would work well is a root mean of the squared gradients for each weight over the recent mini batches to normalize the gradient.

$$g_{ij}^{(t)} = \alpha g_{ij}^{(t-1)} + (1-\alpha) \left(\frac{\partial C^{(t)}}{\partial w_{ij}} \right)^2$$

$$w_{ij}^{(t+1)} = w_{ij}^{(t)} - \frac{\eta}{\sqrt{g_{ij}^{(t)} + \epsilon}} \frac{\partial C^{(t)}}{\partial w_{ij}}$$

where $g^{(t)}$ is the root mean square of the gradients for the weight w_{ij} at iteration t and α is the decay rate for the root mean square gradient for each weight w_{ij} .

Usage

```
train_op = tf.train.RMSPropOptimizer(learning_rate=0.001, decay =0.9,
momentum=0.0, epsilon=1e-10)
```

where decay represents α , epsilon represents ϵ , and η represents the learning rate.

AdadeltaOptimizer

AdadeltaOptimizer is a variant of AdagradOptimizer that is less aggressive in reducing the learning rate. For each weight connection, AdagradOptimizer scales the learning rate constant in an iteration by dividing it by the root mean square of all past gradients for that weight till that iteration. So, the effective learning rate for each weight is a monotonically decreasing function of the iteration number, and after a considerable number of iterations the learning rate becomes infinitesimally small. AdagradOptimizer overcomes this problem by taking the mean of the exponentially decaying squared gradients for each weight or dimension. Hence, the effective learning rate in AdadeltaOptimizer remains more of a local estimate of its current gradients and doesn't shrink as fast as the AdagradOptimizer method. This ensures that learning continues even after a considerable number of iterations or epochs. The learning rule for Adadelta can be summed up as follows:

$$g_{ij}^{(t)} = \gamma g_{ij}^{(t-1)} + (1-\gamma) \left(\frac{\partial C^{(t)}}{\partial w_{ij}} \right)^2$$

$$w_{ij}^{(t+1)} = w_{ij}^{(t)} - \frac{\eta}{\sqrt{g_{ij}^{(t)} + \epsilon}} \frac{\partial C^{(t)}}{\partial w_{ij}}$$

Where γ is the exponential decay constant, η is a learning-rate constant and $g_{ij}^{(t)}$ represents the effective mean square gradient at iteration t . We can denote the term $\sqrt{g_{ij}^{(t)} + \epsilon}$ as $RMS(g_{ij}^{(t)})$, which gives the update rule as follows:

$$w_{ij}^{(t+1)} = w_{ij}^{(t)} - \frac{\eta}{RMS(g_{ij}^{(t)})} \frac{\partial C^{(t)}}{\partial w_{ij}}$$

If we observe carefully, the unit for the change in weight doesn't have the unit of the weight. The units for $\frac{\partial C^{(t)}}{\partial w_{ij}}$ and $RMS(g_{ij}^{(t)})$ are the same—i.e., the unit of gradient (cost function change/per unit weight change)—and hence they cancel each other out. Therefore, the unit of the weight change is the unit of the learning-rate constant. Adadelta solves this problem by replacing the learning-rate constant η with a square root of the mean of the exponentially decaying squared-weight updates up to the current iteration. Let $h_{ij}^{(t)}$ be the mean of the square of the weight updates up to iteration t , β be the decaying constant, and $\Delta w_{ij}^{(t)}$ be the weight update in iteration t . Then, the update rule for $h_{ij}^{(t)}$ and the final weight update rule for Adadelta can be expressed as follows:

$$h_{ij}^{(t)} = \beta h_{ij}^{(t-1)} + (1 - \beta)(\Delta w_{ij}^{(t)})^2$$

$$w_{ij}^{(t+1)} = w_{ij}^{(t)} - \frac{\sqrt{h_{ij}^{(t)} + \epsilon}}{RMS(g_{ij}^{(t)})} \frac{\partial C^{(t)}}{\partial w_{ij}}$$

If we denote $\sqrt{h_{ij}^{(t)} + \epsilon}$ as $RMS(h_{ij}^{(t)})$ then the update rule becomes -

$$w_{ij}^{(t+1)} = w_{ij}^{(t)} - \frac{RMS(h_{ij}^{(t)})}{RMS(g_{ij}^{(t)})} \frac{\partial C^{(t)}}{\partial w_{ij}}$$

Usage

```
train_op = tf.train.AdadeltaOptimizer(learning_rate=0.001, rho=0.95, epsilon=1e-08)
```

where ρ represents γ , ϵ represents ϵ , and η represents the learning rate.

One significant advantage of Adadelta is that it eliminates the learning-rate constant altogether. If we compare Adadelta and RMSprop, both are the same if we leave aside the learning-rate constant elimination. Adadelta and RMSprop were both developed independently around the same time to resolve the fast learning-rate decay problem of Adagrad.

AdamOptimizer

Adam, or Adaptive Moment Estimator, is another optimization technique that, much like RMSprop or Adagrad, has an adaptive learning rate for each parameter or weight. Adam not only keeps a running mean of squared gradients but also keeps a running mean of past gradients.

Let the decay rate of the mean of gradients $m_{ij}^{(t)}$ and the mean of the square of gradients $v_{ij}^{(t)}$ for each weight w_{ij} be β_1 and β_2 respectively. Also, let η be the constant learning-rate factor. Then, the update rules for Adam are as follows:

$$m_{ij}^{(t)} = \beta_1 m_{ij}^{(t-1)} + (1 - \beta_1) \frac{\partial C^{(t)}}{\partial w_{ij}}$$

$$v_{ij}^{(t)} = \beta_2 v_{ij}^{(t-1)} + (1 - \beta_2) \left(\frac{\partial C^{(t)}}{\partial w_{ij}} \right)^2$$

The normalized mean of the gradients $\hat{m}_{ij}^{(t)}$ and the mean of the square gradients $\hat{v}_{ij}^{(t)}$ are computed as follows:

$$\hat{m}_{ij}^{(t)} = \frac{m_{ij}^{(t)}}{(1 - \beta_1^t)}$$

$$\hat{v}_{ij}^{(t)} = \frac{v_{ij}^{(t)}}{(1 - \beta_2^t)}$$

The final update rule for each weight w_{ij} is as follows:

$$w_{ij}^{(t+1)} = w_{ij}^{(t)} - \frac{\eta}{\sqrt{\hat{v}_{ij}^{(t)} + \epsilon}} \hat{m}_{ij}^{(t)}$$

Usage

```
train_op = tf.train.AdamOptimizer(learning_rate=0.001,beta1=0.9,beta2=0.999,epsilon=1e-08).
minimize(cost)
```

where `learning_rate` is the constant learning rate η and `cost` C is the cost function that needs to be minimized through `AdamOptimizer`. The parameters `beta1` and `beta2` correspond to β_1 and β_2 respectively, whereas `epsilon` represents ϵ .

The cost function is minimized with respect to the TensorFlow variables associated with the cost function.

MomentumOptimizer and Nesterov Algorithm

The momentum-based optimizers have evolved to take care of non-convex optimizations. Whenever we are working with neural networks, the cost functions that we generally get are non-convex in nature, and thus the gradient-based optimization methods might get caught up in bad local minima. As discussed earlier, this is highly undesirable since in such cases we get a sub-optimal solution to the optimization problem—and likely a sub-optimal model. Also, gradient descent follows the slope at each point and makes small advances toward the local minima, but it can be terribly slow. Momentum-based methods introduce a component called velocity v that dampens the parameter update when the gradient computed changes sign, whereas it accelerates the parameter update when the gradient is in the same direction of velocity. This introduces faster convergence as well as fewer oscillations around the global minima, or around a local minimum that provides good generalization. The update rule for momentum-based optimizers is as follows:

$$v_i^{(t+1)} = \alpha v_i^{(t)} - \eta \frac{\partial C}{\partial w_i} (w_i^{(t)})$$

$$w_i^{(t+1)} = w_i^{(t)} + v_i^{(t+1)}$$

Where α is the momentum parameter and η is the learning rate. The terms $v_i^{(t)}$ and $v_i^{(t+1)}$ represent the velocity at iterations t and $(t+1)$ respectively for the i th parameter. Similarly, $w_i^{(t)}$ and $w_i^{(t+1)}$ represent the weight of the i th parameter at iterations t and $(t+1)$ respectively.

Imagine that while optimizing a cost function the optimization algorithm reaches a local minimum where $\frac{\partial C}{\partial w_i} (w_i^{(t)}) \rightarrow 0 \forall i \in \mathbb{R}^{n \times 1}$. In normal gradient-descent methods that don't take momentum into

consideration, the parameter update would stop at that local minimum or the saddle point. However, in momentum-based optimization, the prior velocity would drive the algorithm out of the local minima, considering the local minima has a small basin of attraction, as $v_i^{(t+1)}$ would be non-zero because of the non-zero velocity from prior gradients. Also, if the prior gradients consistently pointed toward a global minimum or a local minimum with good generalization and a reasonably large basin of attraction, the velocity or the momentum of gradient descent would be in that direction. So, even if there were a bad local minimum with a small basin of attraction, the momentum component would not only drive the algorithm out of the bad local minima but also would continue the gradient descent toward the global minima or the good local minima.

If the weights are part of the parameter vector θ , the vectorized update rule for momentum-based optimizers would be as follows (refer to Figure 2-22 for the vector-based illustration):

$$v^{(t+1)} = \alpha v^{(t)} - \eta \nabla C (\theta = \theta^{(t)})$$

$$\theta^{(t+1)} = \theta^{(t)} + v^{(t+1)}$$

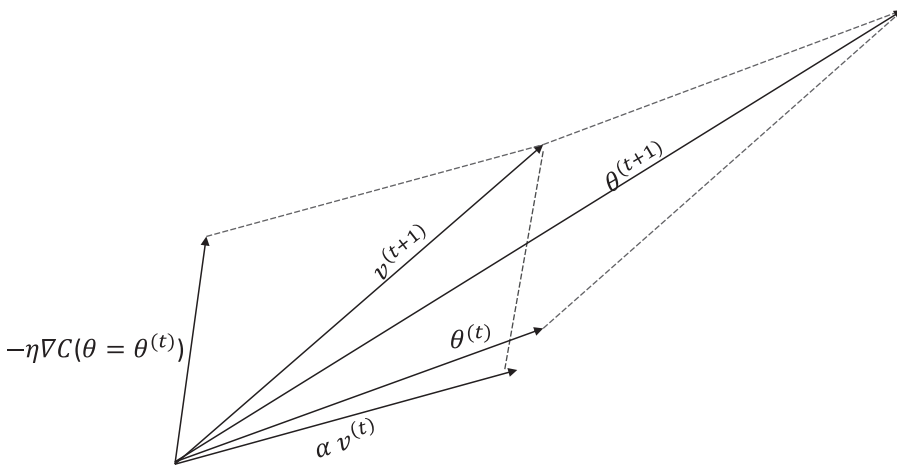

Figure 2-22. Parameter vector update in momentum-based gradient-descent optimizer

A specific variant of momentum-based optimizers is the Nesterov accelerated gradient technique. This method utilizes the existing velocity $v^{(t)}$ to make an update to the parameter vector. Since it's an intermediate update to the parameter vector, it's convenient to denote it by $\theta^{(t+\frac{1}{2})}$. The gradient of the cost function is evaluated at $\theta^{(t+\frac{1}{2})}$, and the same is used to update the new velocity. Finally, the new parameter vector is the sum of the parameter vector at the previous iteration and the new velocity.

$$\theta^{(t+\frac{1}{2})} = \theta^{(t)} + \alpha v^{(t)}$$

$$v^{(t+1)} = \alpha v^{(t)} - \eta \nabla C \left(\theta = \theta^{(t+\frac{1}{2})} \right)$$

$$\theta^{(t+1)} = \theta^{(t)} + v^{(t+1)}$$

Usage

```
train_op = tf.train.MomentumOptimizer.(learning_rate=0.001, momentum=0.9, use_nesterov=False)
```

where `learning_rate` represents η , `momentum` represents α , and `use_nesterov` determines whether to use the Nesterov version of momentum.

Epoch, Number of Batches, and Batch Size

Deep-learning networks, as mentioned earlier, are generally trained through mini-batch stochastic gradient descent. A few of the terms with which we need to familiarize ourselves are as follows:

- **Batch size** – The batch size determines the number of training data points in each mini batch. The batch size should be chosen such that it gives a good enough estimate of the gradient for the full training dataset and at the same time noisy enough to escape bad local minima that don't provide good generalization.
- **Number of batches** – The number of batches gives the total number of mini batches in the entire training dataset. It can be computed by dividing the count of the total training data points by the batch size. Please note that the last mini batch might have a smaller number of data points than the batch size.
- **Epochs** – One epoch consists of one full pass of training over the entire dataset. To be more specific, one epoch is equivalent to a forward pass plus one backpropagation over the entire training dataset. So, one epoch would consist of n number of (forward pass + backpropagation) where n denotes the number of batches.

XOR Implementation Using TensorFlow

Now that we have a decent idea of the components and training methods involved with an artificial neural network, we will implement a XOR network using sigmoid activation functions in the hidden layers as well as in the output. The detailed implementation has been outlined in Listing 2-16.

Listing 2-16. XOR Implementation with Hidden Layers That Have Sigmoid Activation Functions

```
#-----
#XOR implementation in Tensorflow with hidden layers being sigmoid to
# introduce Non-Linearity
#-----
import tensorflow as tf
#-----
# Create placeholders for training input and output labels
#-----
x_ = tf.placeholder(tf.float32, shape=[4,2], name="x-input")
y_ = tf.placeholder(tf.float32, shape=[4,1], name="y-input")
#-----
#Define the weights to the hidden and output layer respectively.
#-----
w1 = tf.Variable(tf.random_uniform([2,2], -1, 1), name="Weights1")
w2 = tf.Variable(tf.random_uniform([2,1], -1, 1), name="Weights2")
#-----
# Define the bias to the hidden and output layers respectively
#-----
b1 = tf.Variable(tf.zeros([2]), name="Bias1")
b2 = tf.Variable(tf.zeros([1]), name="Bias2")
#-----
```

```

# Define the final output through forward pass
#-----
z2 = tf.sigmoid(tf.matmul(x_, w1) + b1)
pred = tf.sigmoid(tf.matmul(z2,w2) + b2)
#-----
#Define the Cross-entropy/Log-loss Cost function based on the output label y and
# the predicted probability by the forward pass
#-----
cost = tf.reduce_mean(( (y_ * tf.log(pred)) +
                        ((1 - y_) * tf.log(1.0 - pred)) ) * -1)
learning_rate = 0.01
train_step = tf.train.GradientDescentOptimizer(learning_rate).minimize(cost)
#-----
#Now that we have all that we need set up we will start the training
#-----
XOR_X = [[0,0],[0,1],[1,0],[1,1]]
XOR_Y = [[0],[1],[1],[0]]
#-----
# Initialize the variables
#-----
init = tf.initialize_all_variables()
sess = tf.Session()
writer = tf.summary.FileWriter("./Downloads/XOR_logs", sess.graph_def)

sess.run(init)
for i in range(100000):
    sess.run(train_step, feed_dict={x_: XOR_X, y_: XOR_Y})

#-----
print('Final Prediction', sess.run(pred, feed_dict={x_: XOR_X, y_: XOR_Y}))
#-----

--output --

('Final Prediction', array([[ 0.06764214],
                             [ 0.93982035],
                             [ 0.95572311],
                             [ 0.05693595]], dtype=float32))

```

In Listing 2-16, the XOR logic is implemented using TensorFlow. The hidden layer units have sigmoid activation functions to introduce non-linearity. The output activation function has a sigmoid activation function to give probability outputs. We are using the gradient-descent optimizer with a learning rate of 0.01 and total iterations of around 100,000. If we see the final prediction, the first and fourth training samples have a near-zero value for probabilities while the second and fourth training samples have probabilities near 1. So, the network can predict the classes accurately and with high precision. Any reasonable threshold would classify the data points correctly.

TensorFlow Computation Graph for XOR network

In Figure 2-23, the computation graph for the preceding implemented XOR network is illustrated. The computation graph summary is written to the log files by including the following line of code. The phrase `./Downloads/XOR_logs` indicates the location where the summary log files have been stored. It can be any location you choose, however.

```
writer = tf.summary.FileWriter("./Downloads/XOR_logs", sess.graph_def)
```

Once the summary has been written to the log files on the terminal, we need to execute the following command to activate Tensorboard:

```
tensorboard --logdir=./Downloads/XOR_logs
```

This would start the Tensorboard session and prompt us to access the Tensorboard at `http://localhost:6006`, where the computation graph could be visualized.

Main Graph

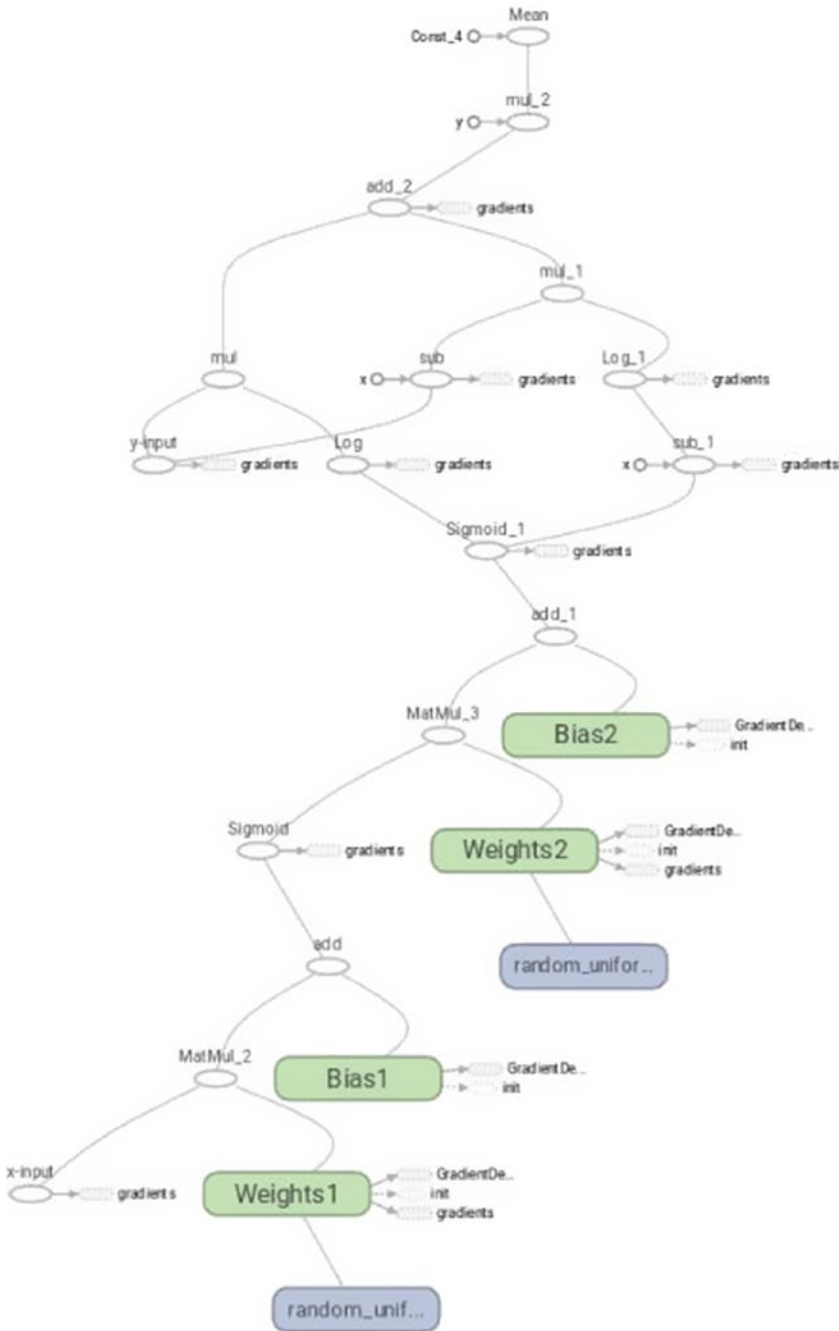

Figure 2-23. Computation graph for the XOR network

Now, we implement the XOR logic again, using linear activation functions in the hidden layer and keeping the rest of the network as it is. Listing 2-17 shows the TensorFlow implementation.

Listing 2-17. XOR Implementation with Linear Activation Functions in Hidden Layer

```

#-----
#XOR implementation in TensorFlow with linear activation for hidden layers
#-----
import tensorflow as tf
#-----
# Create placeholders for training input and output labels
#-----
x_ = tf.placeholder(tf.float32, shape=[4,2], name="x-input")
y_ = tf.placeholder(tf.float32, shape=[4,1], name="y-input")
#-----
#Define the weights to the hidden and output layer respectively.
#-----
w1 = tf.Variable(tf.random_uniform([2,2], -1, 1), name="Weights1")
w2 = tf.Variable(tf.random_uniform([2,1], -1, 1), name="Weights2")
#-----
# Define the bias to the hidden and output layers respectively
#-----
b1 = tf.Variable(tf.zeros([2]), name="Bias1")
b2 = tf.Variable(tf.zeros([1]), name="Bias2")
#-----
# Define the final output through forward pass
#-----
z2 = tf.matmul(x_, w1) + b1
pred = tf.sigmoid(tf.matmul(z2,w2) + b2)
#-----
#Define the Cross-entropy/Log-loss Cost function based on the output label y and the
predicted
#probability by the forward pass
#-----
cost = tf.reduce_mean(( (y_ * tf.log(pred)) +
                        ((1 - y_) * tf.log(1.0 - pred)) ) * -1)
learning_rate = 0.01
train_step = tf.train.GradientDescentOptimizer(learning_rate).minimize(cost)
#-----
#Now that we have all that we need, start the training
#-----
XOR_X = [[0,0],[0,1],[1,0],[1,1]]
XOR_Y = [[0],[1],[1],[0]]

init = tf.initialize_all_variables()
sess = tf.Session()
sess.run(init)
for i in range(100000):
    sess.run(train_step, feed_dict={x_: XOR_X, y_: XOR_Y})

```

```
#-----
print('Final Prediction', sess.run(pred, feed_dict={x_: XOR_X, y_: XOR_Y}))
#-----
```

-- output --

```
('Final Prediction', array([[ 0.5000003 ],
 [ 0.50001115],
 [ 0.49998885],
 [ 0.4999997 ]], dtype=float32))
```

The final predictions as shown in Listing 2-2 are all near 0.5, which means that the implemented XOR logic is not able to do a good job in discriminating the positive class from the negative one. When we have linear activation functions in the hidden layer, the network primarily remains linear, as we have seen previously, and hence the model is not able to do well where non-linear decision boundaries are required to separate classes.

Linear Regression in TensorFlow

Linear regression can be expressed as a single-neuron regression problem. The mean of the square of the errors in prediction is taken as the cost function to be optimized with respect to the co-efficient of the model. Listing 2-18 shows a TensorFlow implementation of linear regression with the Boston housing price dataset.

Listing 2-18. Linear Regression Implementation in TensorFlow

```
#-----
# Importing TensorFlow, Numpy, and the Boston Housing price dataset
#-----

import tensorflow as tf
import numpy as np
from sklearn.datasets import load_boston

#-----
# Function to load the Boston data set
#-----

def read_infile():
    data = load_boston()
    features = np.array(data.data)
    target = np.array(data.target)
    return features,target

#-----
# Normalize the features by Z scaling; i.e., subtract from each feature value its mean and
# then divide by its #standard deviation. Accelerates gradient descent.
#-----

def feature_normalize(data):
    mu = np.mean(data,axis=0)
    std = np.std(data,axis=0)
```

```

    return (data - mu)/std

#-----
# Append the feature for the bias term.
#-----

def append_bias(features,target):
    n_samples = features.shape[0]
    n_features = features.shape[1]
    intercept_feature = np.ones((n_samples,1))
    X = np.concatenate((features,intercept_feature),axis=1)
    X = np.reshape(X,[n_samples,n_features +1])
    Y = np.reshape(target,[n_samples,1])
    return X,Y

#-----
# Execute the functions to read, normalize, and add append bias term to the data
#-----

features,target = read_infile()
z_features = feature_normalize(features)
X_input,Y_input = append_bias(z_features,target)
num_features = X_input.shape[1]

#-----
# Create TensorFlow ops for placeholders, weights, and weight initialization
#-----

X = tf.placeholder(tf.float32,[None,num_features])
Y = tf.placeholder(tf.float32,[None,1])
w = tf.Variable(tf.random_normal((num_features,1)),name='weights')
init = tf.global_variables_initializer()

#-----
# Define the different TensorFlow ops and input parameters for Cost and Optimization.
#-----

learning_rate = 0.01
num_epochs = 1000
cost_trace = []
pred = tf.matmul(X,w)
error = pred - Y
cost = tf.reduce_mean(tf.square(error))
train_op = tf.train.GradientDescentOptimizer(learning_rate).minimize(cost)

#-----
# Execute the gradient-descent learning
#-----

with tf.Session() as sess:
    sess.run(init)
    for i in xrange(num_epochs):

```



```

sess.run(train_op, feed_dict={X:X_input,Y:Y_input})
cost_trace.append(sess.run(cost, feed_dict={X:X_input,Y:Y_input}))
error_ = sess.run(error, {X:X_input,Y:Y_input})
pred_ = sess.run(pred, {X:X_input})

print 'MSE in training:',cost_trace[-1]

-- output --

MSE in training: 21.9711

```

Listing 2-18a. Linear Regression Cost Plot over Epochs or Iterations

```

#-----
# Plot the reduction in cost over iterations or epochs
#-----

import matplotlib.pyplot as plt
%matplotlib inline
plt.plot(cost_trace)

```

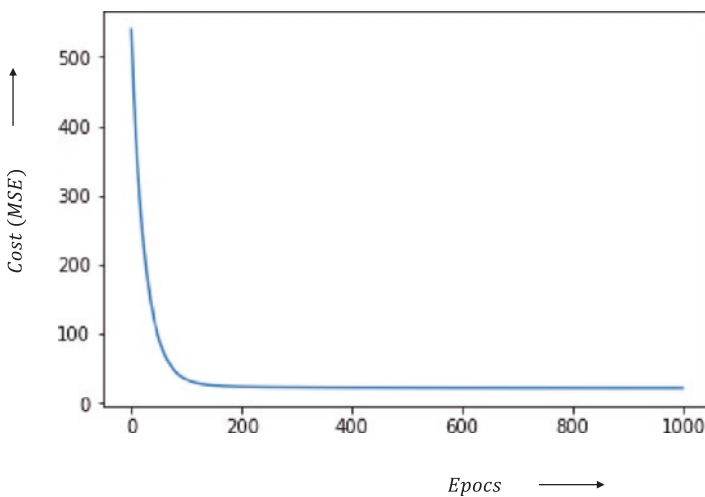

Figure 2-24. Cost (MSE) versus epochs while training

Listing 2-18b. Linear Regression Actual House Price Versus Predicted House Price

```

#-----
# Plot the Predicted House Prices vs the Actual House Prices
#-----

fig, ax = plt.subplots()
plt.scatter(Y_input,pred_)
ax.set_xlabel('Actual House price')
ax.set_ylabel('Predicted House price')

```

**Figure 2-25.** Actual house price versus predicted house price

Figure 2-24 illustrates the cost progression against the epochs and Figure 2-25 illustrates the predicted house price versus the actual house price after training.

Multi-class Classification with SoftMax Function Using Full-Batch Gradient Descent

In this section, we illustrate a multi-class classification problem using full-batch gradient descent. The MNIST dataset has been used because there are 10 output classes corresponding to the 10 integers. The detailed implementation is provided in Listing 2-19. A SoftMax has been used as the output layer.

Listing 2-19. Multi-class Classification with Softmax Function Using Full-Batch Gradient Descent

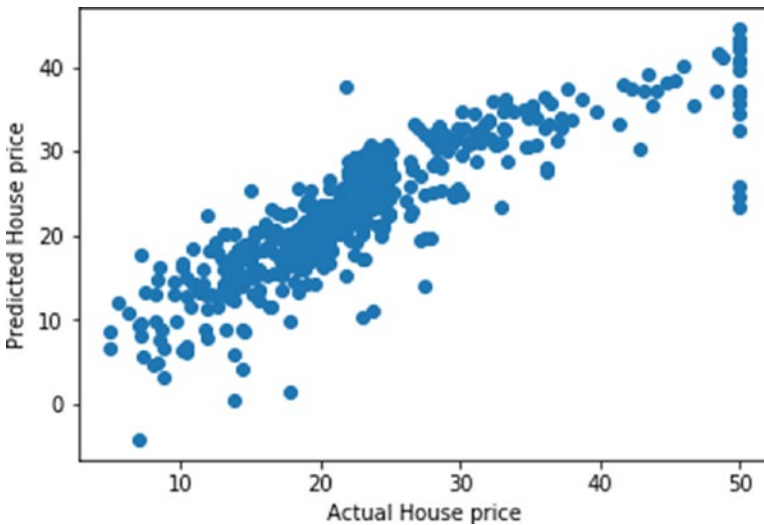
```

#-----
# Import the required libraries
#-----

import tensorflow as tf
import numpy as np

```

```

from sklearn import datasets
from tensorflow.examples.tutorials.mnist import input_data

#-----
# Function to read the MNIST dataset along with the labels
#-----

def read_infile():
    mnist = input_data.read_data_sets("MNIST_data/", one_hot=True)
    train_X, train_Y, test_X, test_Y = mnist.train.images, mnist.train.labels, mnist.test.
    images, mnist.test.labels
    return train_X, train_Y, test_X, test_Y

#-----
# Define the weights and biases for the neural network
#-----

def weights_biases_placeholder(n_dim, n_classes):
    X = tf.placeholder(tf.float32, [None, n_dim])
    Y = tf.placeholder(tf.float32, [None, n_classes])
    w = tf.Variable(tf.random_normal([n_dim, n_classes], stddev=0.01), name='weights')
    b = tf.Variable(tf.random_normal([n_classes]), name='weights')
    return X, Y, w, b

#-----
# Define the forward pass
#-----

def forward_pass(w, b, X):
    out = tf.matmul(X, w) + b
    return out

#-----
# Define the cost function for the SoftMax unit
#-----

def multiclass_cost(out, Y):
    cost = tf.reduce_mean(tf.nn.softmax_cross_entropy_with_logits(logits=out, labels=Y))
    return cost

#-----
# Define the initialization op
#-----

def init():
    return tf.global_variables_initializer()

#-----
# Define the training op
#-----

```

```

def train_op(learning_rate,cost):
    op_train = tf.train.GradientDescentOptimizer(learning_rate).minimize(cost)
    return op_train

train_X, train_Y, test_X, test_Y = read_infile()
X,Y,w,b = weights_biases_placeholder(train_X.shape[1],train_Y.shape[1])
out = forward_pass(w,b,X)
cost = multiclass_cost(out,Y)
learning_rate,epochs = 0.01,1000
op_train = train_op(learning_rate,cost)
init = init()
loss_trace = []
accuracy_trace = []

#-----
# Activate the TensorFlow session and execute the stochastic gradient descent
#-----

with tf.Session() as sess:
    sess.run(init)

    for i in xrange(epochs):
        sess.run(op_train,feed_dict={X:train_X,Y:train_Y})
        loss_ = sess.run(cost,feed_dict={X:train_X,Y:train_Y})
        accuracy_ = np.mean(np.argmax(sess.run(out,feed_dict={X:train_X,Y:train_Y}),axis=1)
== np.argmax(train_Y,axis=1))
        loss_trace.append(loss_)
        accuracy_trace.append(accuracy_)
        if (((i+1) >= 100) and ((i+1) % 100 == 0)) :
            print 'Epoch:',(i+1),'loss:',loss_,'accuracy:',accuracy_

    print 'Final training result:', 'loss:',loss_,'accuracy:',accuracy_
    loss_test = sess.run(cost,feed_dict={X:test_X,Y:test_Y})
    test_pred = np.argmax(sess.run(out,feed_dict={X:test_X,Y:test_Y}),axis=1)
    accuracy_test = np.mean(test_pred == np.argmax(test_Y,axis=1))
    print 'Results on test dataset:', 'loss:',loss_test,'accuracy:',accuracy_test

-- output --
Extracting MNIST_data/train-images-idx3-ubyte.gz
Extracting MNIST_data/train-labels-idx1-ubyte.gz
Extracting MNIST_data/t10k-images-idx3-ubyte.gz
Extracting MNIST_data/t10k-labels-idx1-ubyte.gz
Epoch: 100 loss: 1.56331 accuracy: 0.702781818182
Epoch: 200 loss: 1.20598 accuracy: 0.772127272727
Epoch: 300 loss: 1.0129 accuracy: 0.800363636364
Epoch: 400 loss: 0.893824 accuracy: 0.815618181818
Epoch: 500 loss: 0.81304 accuracy: 0.826618181818
Epoch: 600 loss: 0.754416 accuracy: 0.834309090909
Epoch: 700 loss: 0.709744 accuracy: 0.840236363636
Epoch: 800 loss: 0.674433 accuracy: 0.845
Epoch: 900 loss: 0.645718 accuracy: 0.848945454545

```

```
Epoch: 1000 loss: 0.621835 accuracy: 0.852527272727
Final training result: loss: 0.621835 accuracy: 0.852527272727
Results on test dataset: loss: 0.596687 accuracy: 0.8614
```

Listing 2-19a. Display the Actual Digits Versus the Predicted Digits Along with the Images of the Actual Digits

```
import matplotlib.pyplot as plt
%matplotlib inline
f, a = plt.subplots(1, 10, figsize=(10, 2))
print 'Actual digits: ', np.argmax(test_Y[0:10],axis=1)
print 'Predicted digits:',test_pred[0:10]
print 'Actual images of the digits follow:'
for i in range(10):
    a[i].imshow(np.reshape(test_X[i],[28, 28]))
```

-- output --

```
Actual digits:      [7 2 1 0 4 1 4 9 5 9]
Predicted digits:  [7 2 1 0 4 1 4 9 6 9]
Actual images of the digits follow:
```

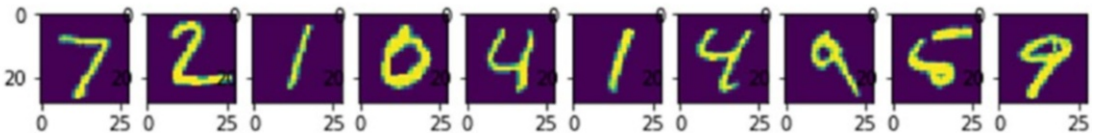

Figure 2-26. Actual digits versus predicted digits for SoftMax classification through gradient descent

Figure 2-26 displays the actual digits versus the predicted digits for SoftMax classification of the validation dataset samples after training through gradient-descent full-batch learning.

Multi-class Classification with SoftMax Function Using Stochastic Gradient Descent

We now perform the same classification task, but instead of using full-batch learning we resort to stochastic gradient descent with a batch size of 1000. The detailed implementation has been outlined in Listing 2-20.

Listing 2-20. Multi-class Classification with Softmax Function Using Stochastic Gradient Descent

```
def read_infile():
    mnist = input_data.read_data_sets("MNIST_data/", one_hot=True)
    train_X, train_Y, test_X, test_Y = mnist.train.images, mnist.train.labels, mnist.test.
images, mnist.test.labels
    return train_X, train_Y, test_X, test_Y
```

```

def weights_biases_placeholder(n_dim,n_classes):
    X = tf.placeholder(tf.float32,[None,n_dim])
    Y = tf.placeholder(tf.float32,[None,n_classes])
    w = tf.Variable(tf.random_normal([n_dim,n_classes],stddev=0.01),name='weights')
    b = tf.Variable(tf.random_normal([n_classes]),name='weights')
    return X,Y,w,b

def forward_pass(w,b,X):
    out = tf.matmul(X,w) + b
    return out

def multiclass_cost(out,Y):
    cost = tf.reduce_mean(tf.nn.softmax_cross_entropy_with_logits(logits=out,labels=Y))
    return cost

def init():
    return tf.global_variables_initializer()

def train_op(learning_rate,cost):
    op_train = tf.train.AdamOptimizer(learning_rate).minimize(cost)
    return op_train

train_X, train_Y,test_X, test_Y = read_infile()
X,Y,w,b = weights_biases_placeholder(train_X.shape[1],train_Y.shape[1])
out = forward_pass(w,b,X)
cost = multiclass_cost(out,Y)
learning_rate,epochs,batch_size = 0.01,1000,1000
num_batches = train_X.shape[0]/batch_size
op_train = train_op(learning_rate,cost)
init = init()
epoch_cost_trace = []
epoch_accuracy_trace = []

with tf.Session() as sess:
    sess.run(init)

    for i in xrange(epochs):
        epoch_cost,epoch_accuracy = 0,0

        for j in xrange(num_batches):
            sess.run(op_train,feed_dict={X:train_X[j*batch_size:(j+1)*batch_
            size],Y:train_Y[j*batch_size:(j+1)*batch_size]})
            actual_batch_size = train_X[j*batch_size:(j+1)*batch_size].shape[0]
            epoch_cost += actual_batch_size*sess.run(cost,feed_dict={X:train_X[j*batch_
            size:(j+1)*batch_size],Y:train_Y[j*batch_size:(j+1)*batch_size]})

```

```

epoch_cost = epoch_cost/float(train_X.shape[0])
epoch_accuracy = np.mean(np.argmax(sess.run(out, feed_dict={X:train_X,Y:train_Y}),
axis=1) == np.argmax(train_Y,axis=1))
epoch_cost_trace.append(epoch_cost)
epoch_accuracy_trace.append(epoch_accuracy)

if (((i + 1) >= 100) and ((i+1) % 100 == 0 )) :
    print 'Epoch:',(i+1),'Average loss:',epoch_cost,'accuracy:',epoch_accuracy

print 'Final epoch training results:', 'Average loss:',epoch_cost,'accuracy:',epoch_
accuracy
loss_test = sess.run(cost,feed_dict={X:test_X,Y:test_Y})
test_pred = np.argmax(sess.run(out,feed_dict={X:test_X,Y:test_Y}),axis=1)
accuracy_test = np.mean(test_pred == np.argmax(test_Y,axis=1))
print 'Results on test dataset:', 'Average loss:',loss_test,'accuracy:',accuracy_test

-- output --
Extracting MNIST_data/train-images-idx3-ubyte.gz
Extracting MNIST_data/train-labels-idx1-ubyte.gz
Extracting MNIST_data/t10k-images-idx3-ubyte.gz
Extracting MNIST_data/t10k-labels-idx1-ubyte.gz
Epoch: 100 Average loss: 0.217337096686 accuracy: 0.9388
Epoch: 200 Average loss: 0.212256691131 accuracy: 0.939672727273
Epoch: 300 Average loss: 0.210445133664 accuracy: 0.940054545455
Epoch: 400 Average loss: 0.209570150484 accuracy: 0.940181818182
Epoch: 500 Average loss: 0.209083143689 accuracy: 0.940527272727
Epoch: 600 Average loss: 0.208780818907 accuracy: 0.9406
Epoch: 700 Average loss: 0.208577176387 accuracy: 0.940636363636
Epoch: 800 Average loss: 0.208430663293 accuracy: 0.940636363636
Epoch: 900 Average loss: 0.208319870586 accuracy: 0.940781818182
Epoch: 1000 Average loss: 0.208232710849 accuracy: 0.940872727273
Final epoch training results: Average loss: 0.208232710849 accuracy: 0.940872727273
Results on test dataset: Average loss: 0.459194 accuracy: 0.9155

```

Listing 2-20a. Actual Digits Versus Predicted Digits for SoftMax Classification Through Stochastic Gradient Descent

```

import matplotlib.pyplot as plt
%matplotlib inline
f, a = plt.subplots(1, 10, figsize=(10, 2))
print 'Actual digits: ', np.argmax(test_Y[0:10],axis=1)
print 'Predicted digits:',test_pred[0:10]
print 'Actual images of the digits follow:'
for i in range(10):
    a[i].imshow(np.reshape(test_X[i],[28, 28]))

--output --

```

Figure 2-27 displays the actual digits versus predicted digits for SoftMax classification of the validation dataset samples after training through stochastic gradient descent.

```
Actual digits:    [7 2 1 0 4 1 4 9 5 9]
Predicted digits: [7 2 1 0 4 1 4 9 6 9]
Actual images of the digits follow:
```

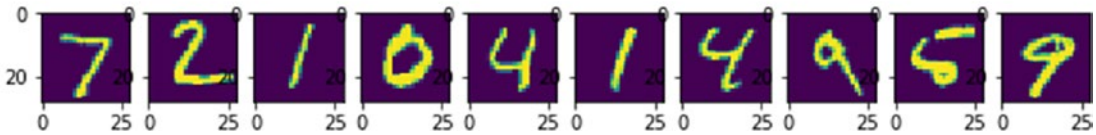

Figure 2-27. Actual digits versus predicted digits for SoftMax classification through stochastic gradient descent

GPU

Before we end this chapter, we want to talk a little about GPU, which has revolutionized the deep-learning world. GPU stands for graphical processing unit, which was initially used for gaming purposes to display more screens per second for better gaming resolution. Deep-learning networks use a lot of matrix multiplication, especially convolution, for both the forward pass and for backpropagation. GPUs are good at matrix-to-matrix multiplication; hence, several thousand cores of GPU are utilized to process data in parallel. This speeds up the deep-learning training. Common GPUs available in the market are

- NVIDIA GTX TITAN XGE
- NVIDIA GTX TITAN X
- NVIDIA GeForce GTX 1080
- NVIDIA GeForce GTX 1070

Summary

In this chapter, we have covered how deep learning has evolved from artificial neural networks over the years. Also, we discussed the Perceptron method of learning, its limitations, and the current method of training neural networks. Problems pertaining to non-convex cost functions, elliptical localized cost contours, and saddle points were discussed in some detail, along with the need for different optimizers to tackle such problems. Also, in the second half of the chapter we caught up on TensorFlow basics and how to execute simple models pertaining to linear regression, multi-class SoftMax, and XOR classification through TensorFlow. In the next chapter, the emphasis is going to be on convolutional neural networks for images.

CHAPTER 3



Convolutional Neural Networks

Artificial neural networks have flourished in recent years in the processing of unstructured data, especially images, text, audio, and speech. Convolutional neural networks (CNNs) work best for such unstructured data. Whenever there is a topology associated with the data, convolutional neural networks do a good job of extracting the important features out of the data. From an architectural perspective, CNNs are inspired by multi-layer Perceptrons. By imposing local connectivity constraints between neurons of adjacent layers, CNN exploits local spatial correlation.

The core element of convolutional neural networks is the processing of data through the convolution operation. Convolution of any signal with another signal produces a third signal that may reveal more information about the signal than the original signal itself. Let's go into detail about convolution before we dive into convolutional neural networks.

Convolution Operation

The convolution of a temporal or spatial signal with another signal produces a modified version of the initial signal. The modified signal may have better feature representation than the original signal suitable for a specific task. For example, by convolving a grayscale image as a 2D signal with another signal, generally called a filter or kernel, an output signal can be obtained that contains the edges of the original image. Edges in an image can correspond to object boundaries, changes in illumination, changes in material property, discontinuities in depth, and so on, which may be useful for several applications. Knowledge about the linear time invariance or shift invariance properties of systems helps one appreciate the convolution of signals better. We will discuss this first before moving on to convolution itself.

Linear Time Invariant (LTI) / Linear Shift Invariant (LSI) Systems

A system works on an input signal in some way to produce an output signal. If an input signal $x(t)$ produces an output, $y(t)$, then $y(t)$ can be expressed as

$$y(t) = f(x(t))$$

For the system to be linear, the following properties for scaling and superposition should hold true:

$$\textbf{Scaling: } f(\alpha x(t)) = \alpha f(x(t))$$

$$\textbf{Superposition: } f(\alpha x_1(t) + \beta x_2(t)) = \alpha f(x_1(t)) + \beta f(x_2(t))$$

Similarly, for the system to be time invariant or in general shift invariant,

$$f(x(t-\tau))=y(t-\tau)$$

Such systems that have properties of linearity and shift invariance are termed linear shift invariant (LSI) systems in general. When such systems work on time signals, they are referred to as linear time invariant (LTI) systems. For the rest of the chapter, we will refer to such systems as LSI systems without any loss of generality. See Figure 3-1.

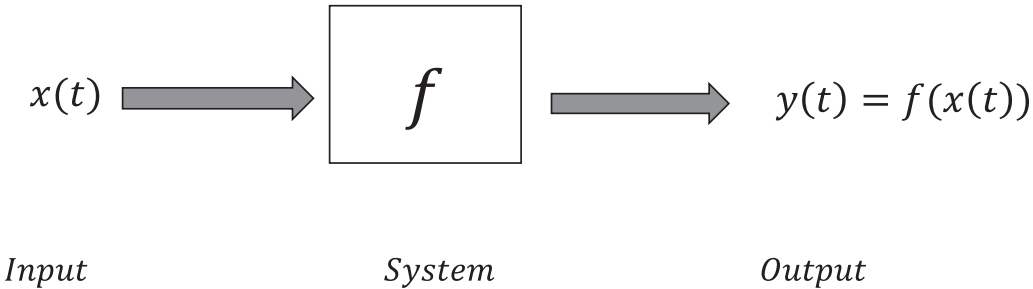

Figure 3-1. Input-Output system

The key feature of an LSI system is that if one knows the output of the system to an impulse response then one can compute the output response to any signal.

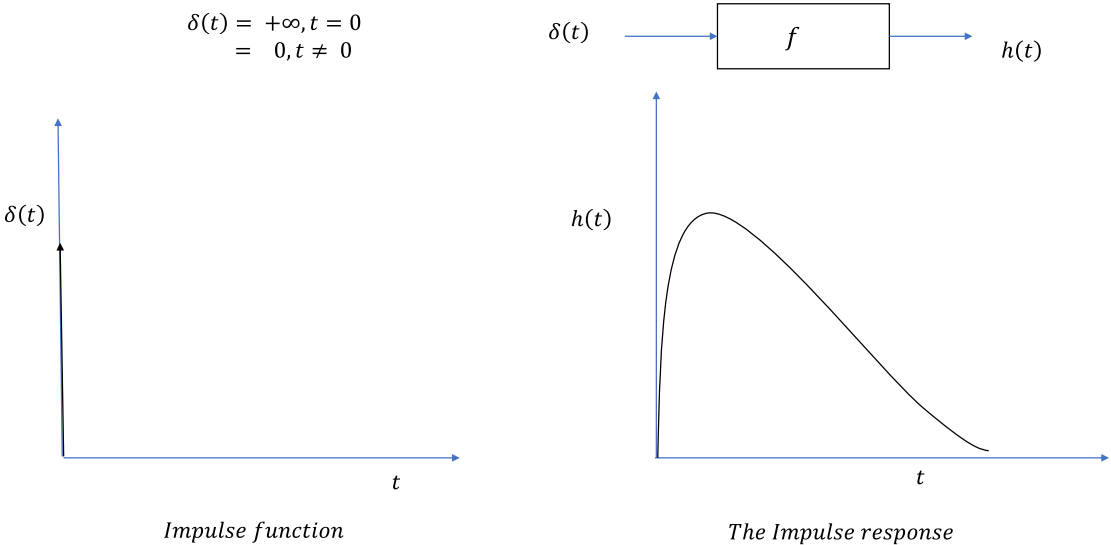

Figure 3-2a. Response of an LSI system to an impulse (Dirac Delta) function

In Figures 3-2a and 3-2b we illustrate the impulse response of the systems to different kinds of impulse functions. Figure 3-2a shows the continuous impulse response of the system to a Dirac Delta impulse, whereas Figure 3-2b shows the discrete impulse response of the system to a step impulse function. The system in Figure 3-2a is a continuous LTI system, and hence a Dirac Delta is required to determine its impulse response. On the other hand, the system in Figure 3-2b is a discrete LTI system and so a unit step impulse is needed to determine its impulse response.

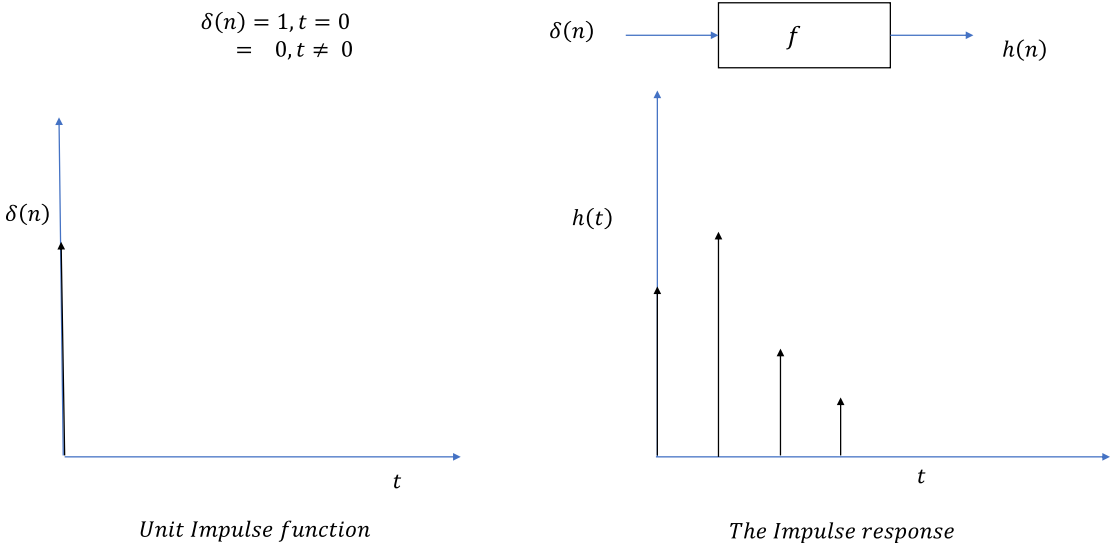

Figure 3-2b. Response of an LTI system to a unit step impulse

Once we know the response $h(t)$ of an LSI system to an impulse function $\delta(t)$ we can compute the response $y(t)$ of the LTI system to any arbitrary input signal $x(t)$ by convolving it with $h(t)$. Mathematically, it can be expressed as $y(t) = x(t) (*) h(t)$, where the $(*)$ operation denotes convolution.

The impulse response of a system can either be known or be determined from the system by noting down its response to an impulse function. For example, the impulse response of a Hubble space telescope can be found out by focusing it on a distant star in the dark night sky and then noting down the recorded image. The recorded image is the impulse response of the telescope.

Convolution for Signals in One Dimension

Intuitively, convolution measures the degree of overlap between one function and the reversed and translated version of another function. In the discrete case,

$$y(t) = x(t) (*) h(t) = \sum_{\tau=-\infty}^{+\infty} x(\tau) h(t-\tau)$$

Similarly, in the continuous domain the convolution of two functions can be expressed as

$$y(t) = x(t) (*) h(t) = \int_{\tau=-\infty}^{+\infty} x(\tau) h(t-\tau) d\tau$$

Let's perform convolution of two discrete signals to better interpret this operation. See Figures 3-3a to 3-3c.

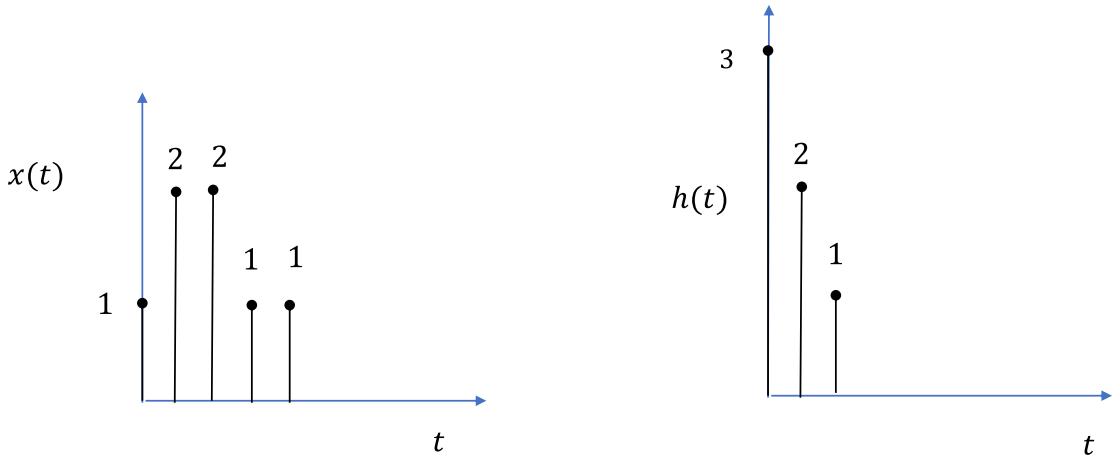

Figure 3-3a. Input signals

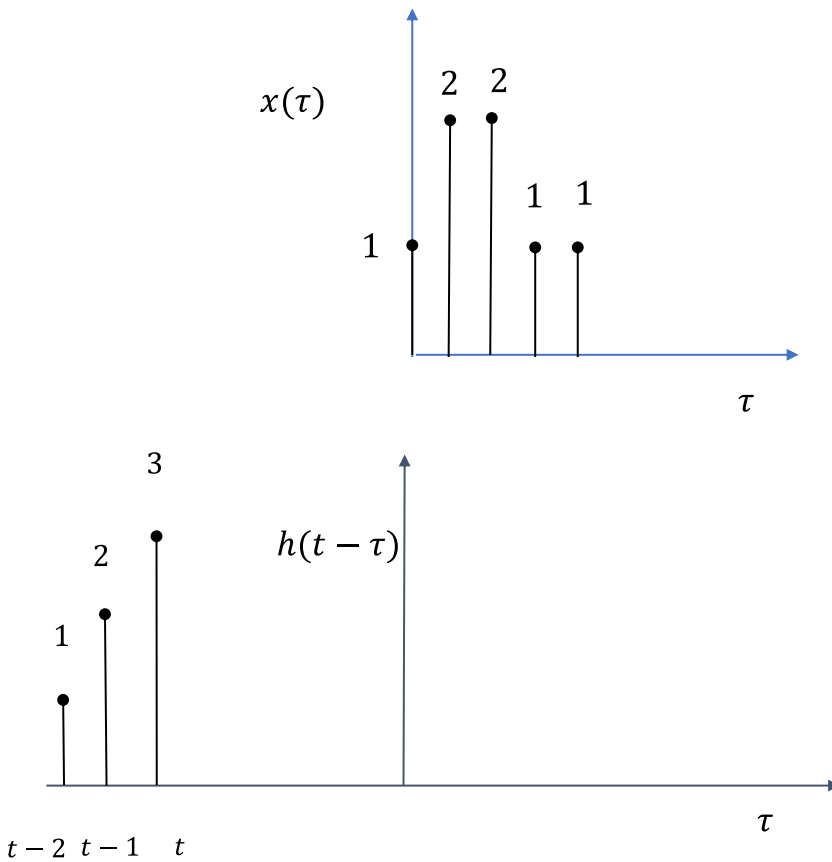

Figure 3-3b. Functions for computing convolution operation

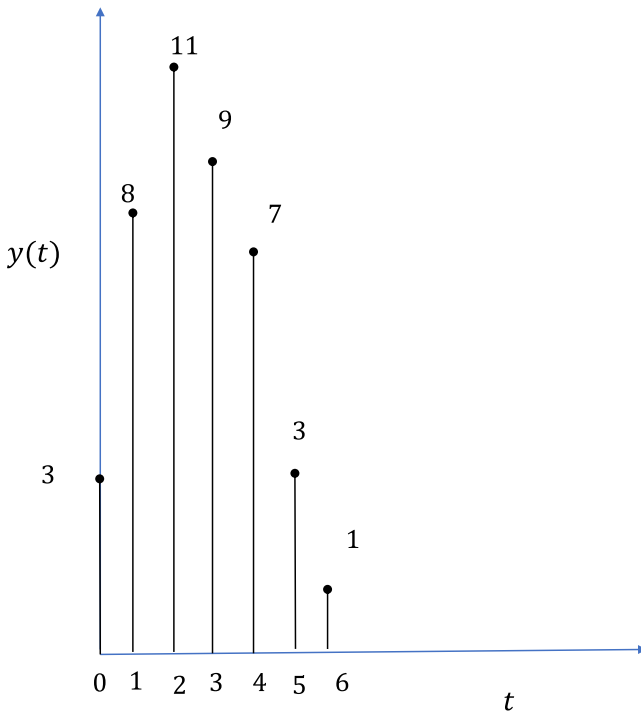

Figure 3-3c. Output function from convolution

In Figure 3-3b, the function $h(t-\tau)$ needs to be computed for different values of t by sliding it across the horizontal axis. At each value of t the convolution sum $\sum_{\tau=-\infty}^{+\infty} x(\tau)h(t-\tau)$ needs to be computed. The sum can be thought of as a weighted average of $x(\tau)$ with the weights being provided by $h(t-\tau)$.

- When $t=-1$ the weights are given by $h(1-\tau)$ but the weights don't overlap with $x(\tau)$ and hence the sum is 0.
- When $t=0$ the weights are given by $h(-\tau)$ and the only element of $x(\tau)$ in overlap with the weights is $x(\tau=0)$, the overlapping weight being $h(0)$. Hence, the convolving sum is $x(\tau=0) * h(0) = 1 * 3 = 3$. Thus, $y(0) = 3$.
- When $t=1$ the weights are given by $h(1-\tau)$. The elements $x(0)$ and $x(1)$ are in overlap with the weights $h(1)$ and $h(0)$ respectively. Hence, the convolving sum is $x(0) * h(1) + x(1) * h(0) = 1 * 2 + 2 * 3 = 8$.
- When $t=2$ the weights are given by $h(2-\tau)$. The elements $x(0)$, $x(1)$, and $x(2)$ are in overlap with the weights $h(2)$, $h(1)$, and $h(0)$ respectively. Hence, the convolving sum is elements $x(0) * h(2) + x(1) * h(1) + x(2) * h(0) = 1 * 1 + 2 * 2 + 2 * 3 = 11$. The overlap of the two functions for $t=2$ is illustrated in Figure 3-3d.

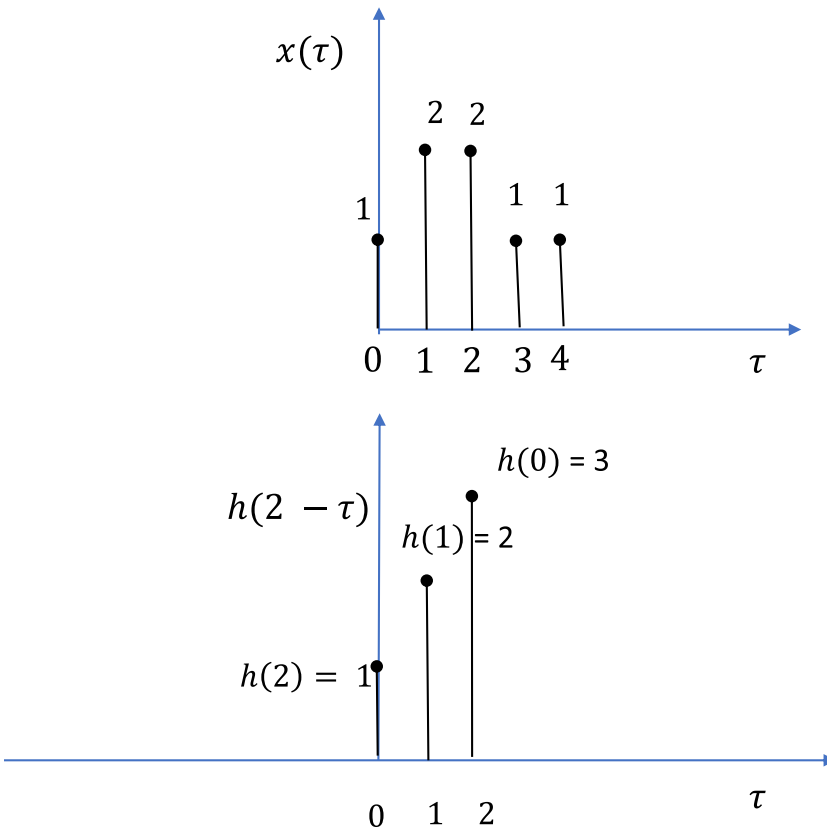

Figure 3-3d. *Overlap of the functions in convolution at $t = 2$*

Analog and Digital Signals

In general, any quantity of interest that shows variation in time and/or space represents a signal. Hence, a signal is a function of time and/or space. For instance, the stock market prices of a specific stock over a period of a week represent a signal.

Signals can be analogous or digital in nature. However, a computer can't process analogous continuous signals, so the signal is made into a digital signal for processing. For example, speech is an acoustic signal in time where both time and the amplitude of the speech energy are continuous signals. When the speech is transmitted through a microphone, this acoustic continuous signal is converted into an electrical continuous signal. If we want to process the analog electrical signal through a digital computer, we need to convert the analog continuous signal into a discrete signal. This is done through sampling and quantization of the analog signal.

Sampling refers to taking the signal amplitudes only at fixed spatial or time intervals. This has been illustrated in Figure 3-4a.

Not all possible continuous values of the signal amplitude are generally noted, but the signal amplitude is generally quantized to some fixed discrete values, as shown in Figure 3-4b. Through sampling and quantization some information is lost from the analog continuous signal.

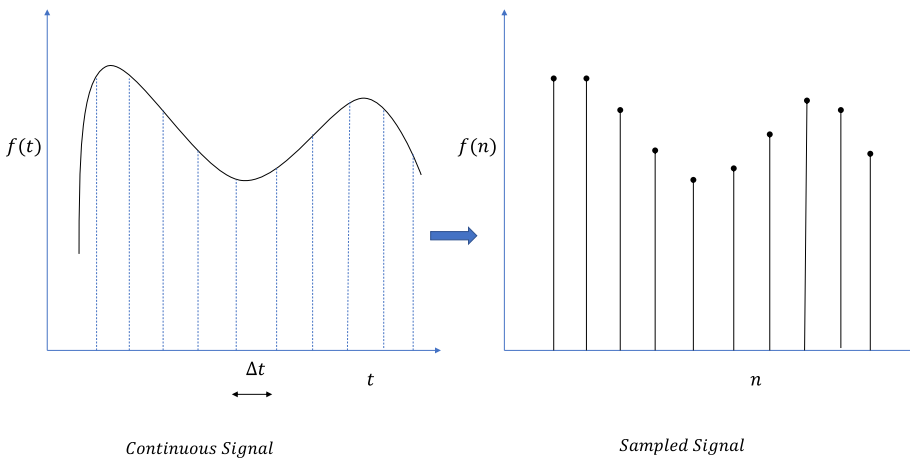

Figure 3-4a. Sampling of a signal

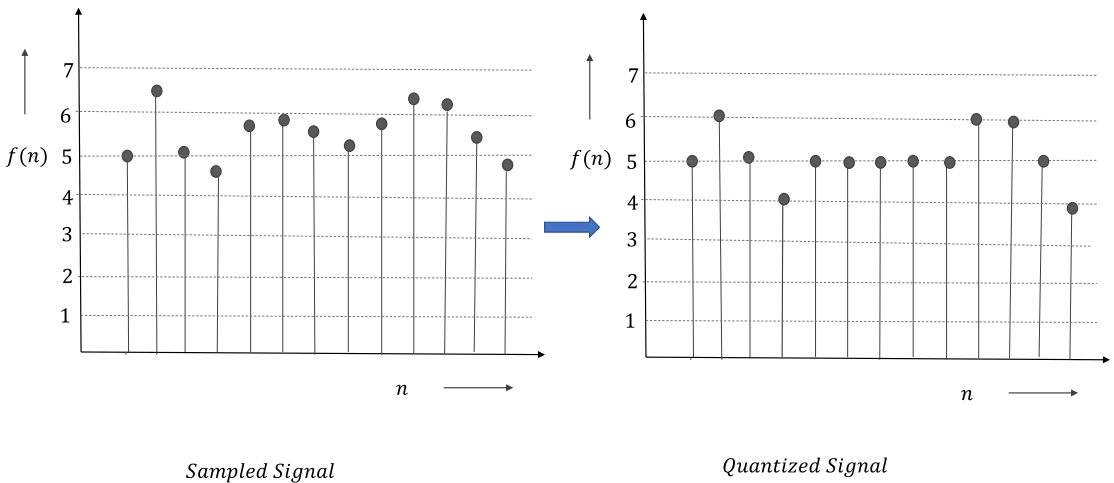

Figure 3-4b. Quantization of signal at discrete amplitude values

The activities of sampling and quantization convert an analog signal to a digital one.

A digital image can be expressed as a digital signal in the two-dimensional spatial domain. The colored RGB image has three channels: Red, Green, and Blue. Each of the channels can be considered a signal in the spatial domain such that at each spatial location the signal is represented by a pixel intensity. Each pixel can be represented by 8 bits, which in binary allows for 256 pixel intensities from 0 to 255. The color at any location is determined by the vector of pixel intensities at that location corresponding to the three channels. So, to represent a specific color, 24 bits of information is used. For a grayscale image, there is only one channel, and the pixel intensities range from 0 to 255. 255 represents the color white, while 0 represents the color black.

A video is a sequence of images with a temporal dimension. A black and white video can be expressed as a signal of its spatial and temporal coordinates (x, y, t) . A colored video can be expressed as a combination of three signals, with the spatial and temporal coordinates corresponding to the three color channels—Red, Green, and Blue.

So, a grayscale $n \times m$ image can be expressed as function $I(x, y)$, where I denotes the intensity of the pixel at the x, y coordinate. For a digital image, the x, y are sampled coordinates and take discrete values. Similarly, the pixel intensity is quantized between 0 and 255.

2D and 3D signals

A grayscale image of dimension $N \times M$ can be expressed as a scalar 2D signal of its spatial coordinates. The signal can be represented as

$$x(n_1, n_2), \quad 0 < n_1 < M - 1, 0 < n_2 < N - 1$$

where n_1 and n_2 are the discrete spatial coordinates along the horizontal and vertical axes respectively and $x(n_1, n_2)$ denotes the pixel intensity at the spatial coordinates. The pixel intensities take up values from 0 to 255.

A colored RGB image is a vector 2D signal since there is a vector of pixel intensities at each spatial coordinate. For an RGB image of dimensions $N \times M \times 3$, the signal can be expressed as

$$x(n_1, n_2) = [x_R(n_1, n_2), x_G(n_1, n_2), x_B(n_1, n_2)], \quad 0 < n_1 < M - 1, 0 < n_2 < N - 1$$

where $x_R, x_G,$ and x_B denote the pixel intensities along the Red, Green, and Blue color channels. See Figures 3-5a and 3-5b.

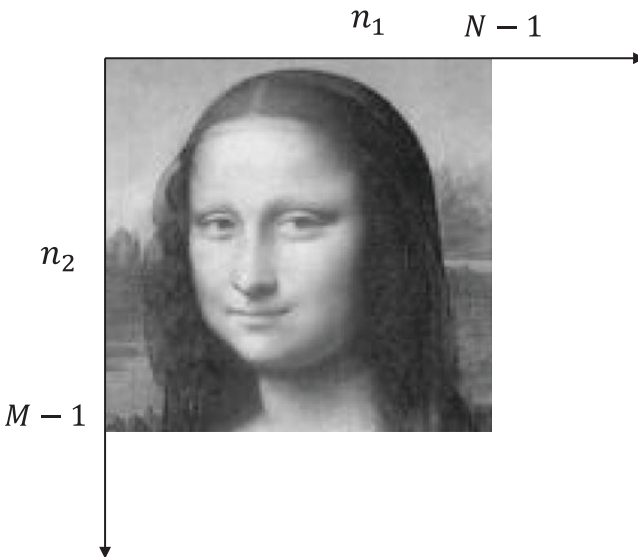

Figure 3-5a. Grayscale image as a 2D discrete signal

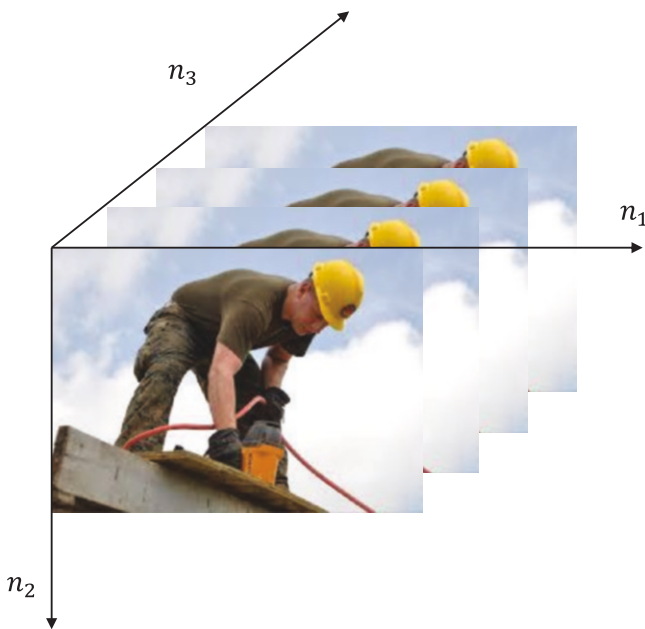

Figure 3-5b. Video as a 3D object

2D Convolution

Now that we have expressed grayscale images as 2D signals, we would like to process those signals through 2D convolution. The images can be convolved with the impulse response of an image-processing system to achieve different objectives, such as the following:

- Remove the visible noise in the image through noise-reduction filters. For white noise, we can use a Gaussian filter. For salt and pepper noise, a median filter can be used.
- For detecting edges, we need filters that extract high-frequency components from an image.

The image-processing filters can be thought of as image-processing systems that are linear and shift invariant. Before we go to image processing, it's worthwhile to know the different impulse functions.

Two-dimensional Unit Step Function

A two-dimensional unit step function $\delta(n_1, n_2)$, where n_1 and n_2 are the horizontal and vertical coordinates, can be expressed as

$$\delta(n_1, n_2) = \begin{cases} 1 & \text{when } n_1 = 0 \text{ and } n_2 = 0 \\ 0 & \text{elsewhere} \end{cases}$$

Similarly, a shifted unit step function can be expressed as

$$\delta(n_1 - k_1, n_2 - k_2) = 1 \text{ when } n_1 = k_1 \text{ and } n_2 = k_2 \\ = 0 \text{ elsewhere}$$

This has been illustrated in Figure 3-6.

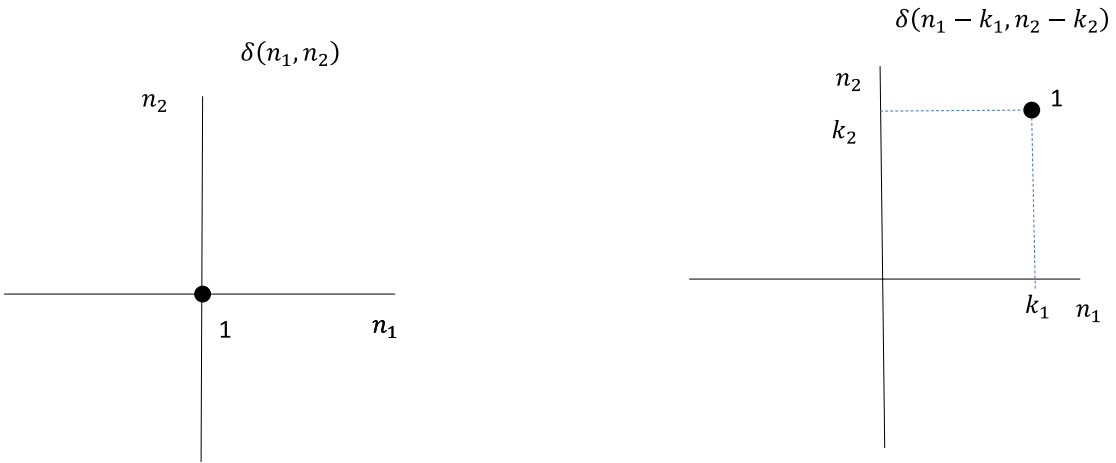

Figure 3-6. Unit step functions

Any discrete two-dimensional signal can be expressed as the weighted sum of unit step functions at different coordinates. Let's consider the signal $x(n_1, n_2)$ as shown in Figure 3-7.

$$x(n_1, n_2) = 1 \text{ when } n_1 = 0 \text{ and } n_2 = 0 \\ = 2 \text{ when } n_1 = 0 \text{ and } n_2 = 1 \\ = 3 \text{ when } n_1 = 1 \text{ and } n_2 = 1 \\ = 0 \text{ elsewhere} \\ x(n_1, n_2) = x(0,0) * \delta(n_1, n_2) + x(0,1) * \delta(n_1, n_2 - 1) + x(1,1) * \delta(n_1 - 1, n_2 - 1) \\ = 1 * \delta(n_1, n_2) + 2 * \delta(n_1, n_2 - 1) + 3 * \delta(n_1 - 1, n_2 - 1)$$

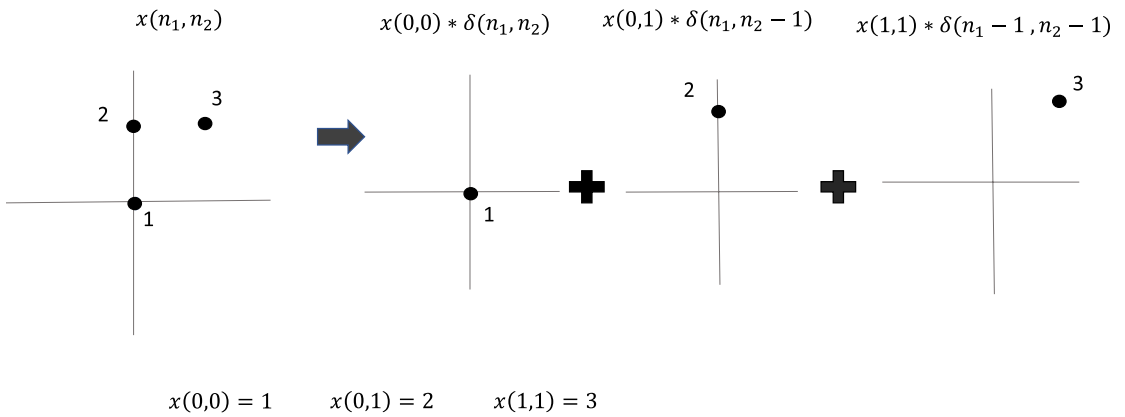

Figure 3-7. Representing a 2D discrete signal as the weighted sum of unit step functions

So, in general, any discrete 2D signal can be written as follows:

$$x(n_1, n_2) = \sum_{k_2=-\infty}^{+\infty} \sum_{k_1=-\infty}^{+\infty} x(k_1, k_2) \delta(n_1 - k_1, n_2 - k_2)$$

2D Convolution of a Signal with an LSI System Unit Step Response

When any discrete 2D signal as expressed above signal passes through an LSI system with transformation f , then, because of the linearity property of LSI systems,

$$f(x(n_1, n_2)) = \sum_{k_2=-\infty}^{+\infty} \sum_{k_1=-\infty}^{+\infty} x(k_1, k_2) f(\delta(n_1 - k_1, n_2 - k_2))$$

Now, the unit step response of an LSI system $f(\delta(n_1, n_2)) = h(n_1, n_2)$, and since an LSI system is shift invariant, $f(\delta(n_1 - k_1, n_2 - k_2)) = h(n_1 - k_1, n_2 - k_2)$.

Hence, $f(x(n_1, n_2))$ can be expressed as follows:

$$f(x(n_1, n_2)) = \sum_{k_2=-\infty}^{+\infty} \sum_{k_1=-\infty}^{+\infty} x(k_1, k_2) h(n_1 - k_1, n_2 - k_2) \quad (1)$$

The preceding expression denotes the expression for 2D convolution of a signal with the unit step response of an LSI system. To illustrate 2D convolution, let's walk through an example in which we convolve $x(n_1, n_2)$ with $h(n_1, n_2)$. The signal and the unit step response signal are defined as follows, and have also been illustrated in Figure 3-8:

$$\begin{aligned}
 x(n_1, n_2) &= 4 && \text{when } n_1 = 0, n_2 = 0 \\
 &= 5 && \text{when } n_1 = 1, n_2 = 0 \\
 &= 2 && \text{when } n_1 = 0, n_2 = 1 \\
 &= 3 && \text{when } n_1 = 1, n_2 = 1 \\
 &= 0 && \text{elsewhere} \\
 h(n_1, n_2) &= 1 && \text{when } n_1 = 0, n_2 = 0 \\
 &= 2 && \text{when } n_1 = 1, n_2 = 0 \\
 &= 3 && \text{when } n_1 = 0, n_2 = 1 \\
 &= 4 && \text{when } n_1 = 1, n_2 = 1 \\
 &= 0 && \text{elsewhere}
 \end{aligned}$$

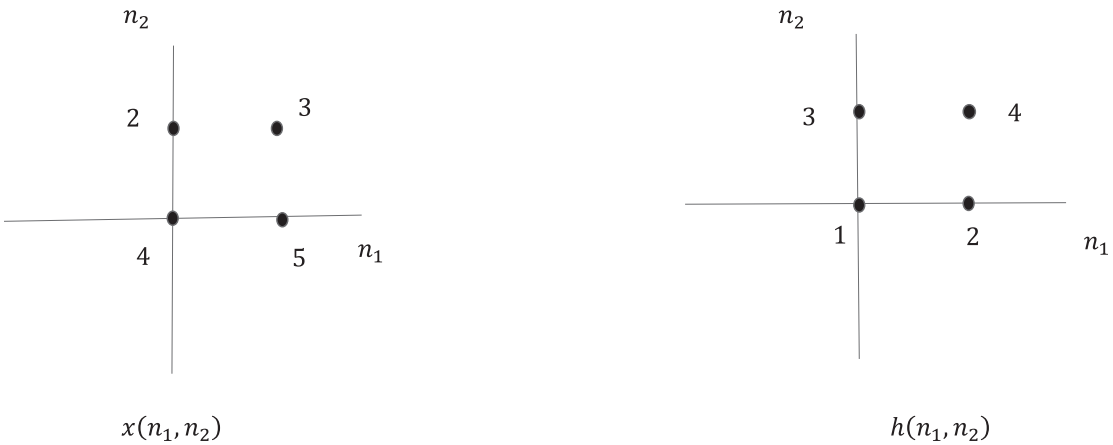

Figure 3-8. 2D signal and unit step response of LSI system

To compute the convolution, we need to plot the signals on a different set of coordinate points. We chose k_1 and k_2 on the horizontal and vertical axes respectively. Also, we reverse the impulse response $h(k_1, k_2)$ to $h(-k_1, -k_2)$ as plotted in Figure 3-9(b). We then place the reversed function $h(-k_1, -k_2)$ at different offset values for n_1 and n_2 . The generalized reversed function can be expressed as $h(n_1 - k_1, n_2 - k_2)$. For computing the output $y(n_1, n_2)$ of convolution at a specific value of n_1 and n_2 , we see the points at which $h(n_1 - k_1, n_2 - k_2)$ overlaps with $x(k_1, k_2)$ and take the total sum of the coordinate-wise product of the signal and impulse response values as the output.

As we can see in Figure 3-9(c), for the $(n_1 = 0, n_2 = 0)$ offset the only point of overlap is $(k_1 = 0, k_2 = 0)$ and so $y(0,0) = x(0,0) * h(0,0) = 4 * 1 = 4$.

Similarly, for offset $(n_1 = 1, n_2 = 0)$, the points of overlap are the points $(k_1 = 0, k_2 = 0)$ and $(k_1 = 1, k_2 = 0)$, as shown in Figure 3-9(d).

$$\begin{aligned}
 y(1,0) &= x(0,0) * h(1-0,0-0) + x(1,0) * h(1-1,0-0) \\
 &= x(0,0) * h(1,0) + x(1,0) * h(0,0) \\
 &= 4 * 2 + 5 * 1 = 13
 \end{aligned}$$

For offset $(n_1=1, n_2=1)$, the points of overlap are the points $(k_1=1, k_2=0)$, as shown in Figure 3-9(e).

$$\begin{aligned}
 y(2,0) &= x(1,0) * h(2-1,0-0) \\
 &= x(1,0) * h(1,0) \\
 &= 5 * 2 = 10
 \end{aligned}$$

Following this approach of shifting the unit step response signal by altering n_1 and n_2 , the entire function $y(n_1, n_2)$ can be computed.

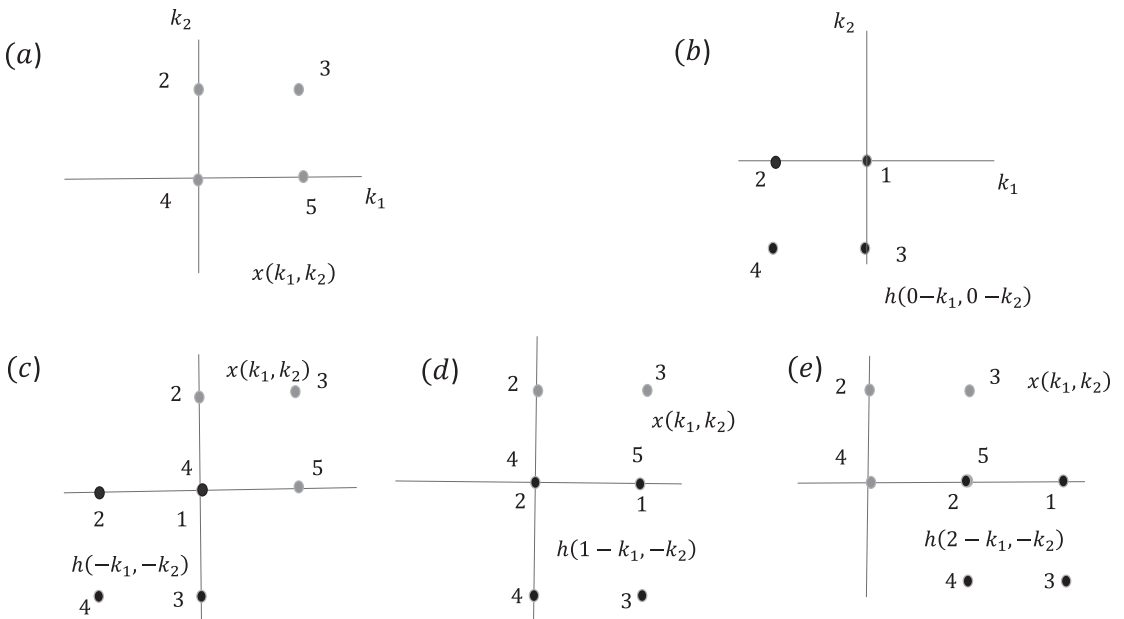

Figure 3-9. Convolution at different coordinate points

2D Convolution of an Image to Different LSI System Responses

Any image can be convolved with an LSI system’s unit step response. Those LSI system unit step responses are called filters or kernels. For example, when we try to take an image through a camera and the image gets blurred because of shaking of hands, the blur introduced can be treated as an LSI system with a specific unit step response. This unit step response convolves the actual image and produces the blurred image as output. Any image that we take through the camera gets convolved with the unit step response of the camera. So, the camera can be treated as an LSI system with a specific unit step response.

Any digital image is a 2D discrete signal. The convolution of an $N \times M$ 2D image $x(n_1, n_2)$ with a 2D image-processing filter $h(n_1, n_2)$ is given by

$$y(n_1, n_2) = \sum_{k_2=0}^{N-1} \sum_{k_1=0}^{M-1} x(k_1, k_2) h(n_1 - k_1, n_2 - k_2)$$

where $0 \leq n_1 \leq N - 1, 0 \leq n_2 \leq M - 1$.

The image-processing filters work on a grayscale image's (2D) signal to produce another image (2D signal). In cases of multi-channel images, generally 2D image-processing filters are used for image processing, which means one must process each image channel as a 2D signal or convert the image into a grayscale image.

Now that we have gone through the concepts of convolution, we know to term any unit step response of an LSI system with which we convolve an image as a filter or kernel.

An example of 2D convolution is illustrated in Figure 3-10a.

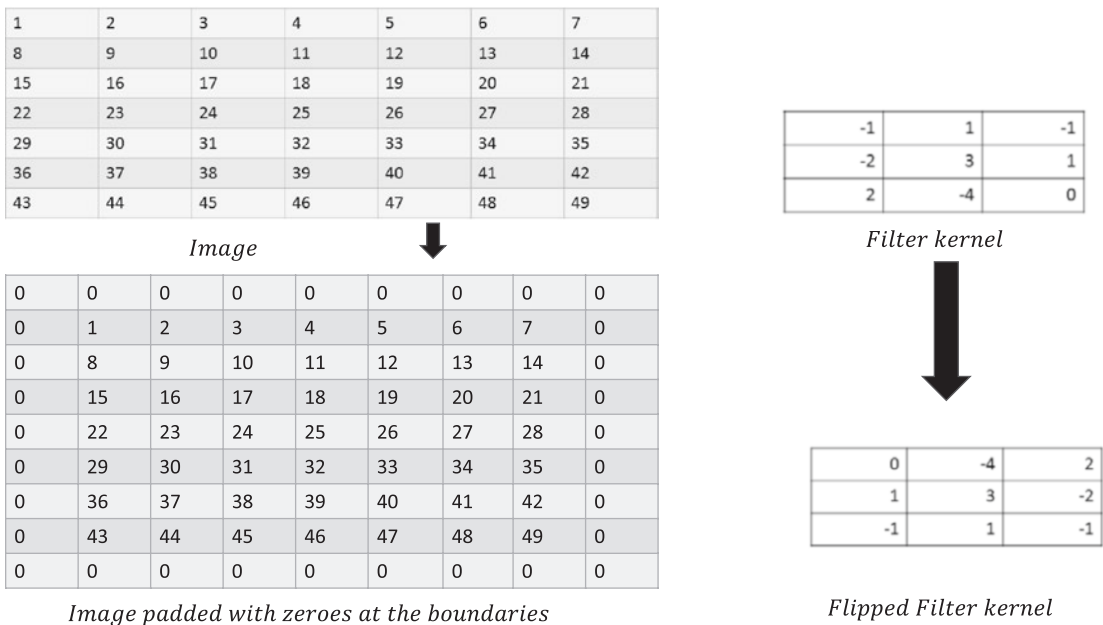

Figure 3-10a. Example of 2D convolution of images

0	0	0	-4	0	2	0	0	0	0	0	0
0	1	1	3	2	-2	3	4	5	6	7	0
0	-1	8	1	9	-1	10	11	12	13	14	0
0	15	16	17	18	19	20	21	21	0	0	0
0	22	23	24	25	26	27	28	28	0	0	0
0	29	30	31	32	33	34	35	35	0	0	0
0	36	37	38	39	40	41	42	42	0	0	0
0	43	44	45	46	47	48	49	49	0	0	0
0	0	0	0	0	0	0	0	0	0	0	0

$$I[0,0] = 1 \times 3 + 2 \times -2 + 8 \times 1 + 9 \times -1 = -2$$

0	0	0	0	-4	0	2	0	0	0	0	0
0	1	1	2	3	3	-2	4	5	6	7	0
0	8	-1	9	1	10	-1	11	12	13	14	0
0	15	16	17	18	19	20	21	21	0	0	0
0	22	23	24	25	26	27	28	28	0	0	0
0	29	30	31	32	33	34	35	35	0	0	0
0	36	37	38	39	40	41	42	42	0	0	0
0	43	44	45	46	47	48	49	49	0	0	0
0	0	0	0	0	0	0	0	0	0	0	0

$$I[0,1] = 1 \times 1 + 2 \times 3 + 3 \times -2 + 8 \times -1 + 9 \times 1 + 10 \times -1 = -8$$

0	0	0	0	0	0	0	0	0	-4	0	2
0	1	2	3	4	5	6	1	7	3	0	-2
0	8	9	10	11	12	13	13	-1	14	1	-1
0	15	16	17	18	19	20	21	21	0	0	0
0	22	23	24	25	26	27	28	28	0	0	0
0	29	30	31	32	33	34	35	35	0	0	0
0	36	37	38	39	40	41	42	42	0	0	0
0	43	44	45	46	47	48	49	49	0	0	0
0	0	0	0	0	0	0	0	0	0	0	0

$$I[0,6] = 6 \times 1 + 7 \times 3 + 13 \times -1 + 14 \times 1 = 28$$

Figure 3-10b.

To keep the length of the output image the same as that of the input image, the original image has been zero padded. As we can see, the flipped filter or kernel is slid over various areas of the original image, and the convolution sum is computed at each coordinate point. Please note that the indexes in the intensity $I[i,j]$ as mentioned in Figure 3-10b denote the matrix coordinates. The same example problem is worked out through scipy 2D convolution as well as through basic logic in Listing 3-1. In both cases the results are the same.

Listing 3-1.

```
## Illustrate 2D convolution of images through an example
```

```
import scipy.signal
import numpy as np
# Take a 7x7 image as example
image = np.array([[1, 2, 3, 4, 5, 6, 7],
                  [8, 9, 10, 11, 12, 13, 14],
                  [15, 16, 17, 18, 19, 20, 21],
                  [22, 23, 24, 25, 26, 27, 28],
                  [29, 30, 31, 32, 33, 34, 35],
                  [36, 37, 38, 39, 40, 41, 42],
                  [43, 44, 45, 46, 47, 48, 49]])

# Defined an image-processing kernel
filter_kernel = np.array([[-1, 1, -1],
                           [-2, 3, 1],
                           [2, -4, 0]])
```

```
# Convolve the image with the filter kernel through scipy 2D convolution to produce an
output image of same dimension as that of the input
```

```
I = scipy.signal.convolve2d(image, filter_kernel,mode='same', boundary='fill', fillvalue=0)
print(I)
```

```
# We replicate the logic of a scipy 2D convolution by going through the following steps
# a) The boundaries need to be extended in both directions for the image and padded with
zeroes.
```

```
# For convolving the 7x7 image by 3x3 kernel, the dimensions need to be extended by
(3-1)/2-i.e., 1-
```

```
#on either side for each dimension. So a skeleton image of 9x9 image would be created
# in which the boundaries of 1 pixel are pre-filled with zero.
```

```
# b) The kernel needs to be flipped-i.e., rotated-by 180 degrees
```

```
# c) The flipped kernel needs to be placed at each coordinate location for the image and then
the sum of
```

```
#coordinate-wise product with the image intensities needs to be computed. These sums for
each coordinate would give
```

```
#the intensities for the output image.
```

```
row,col=7,7
```

```
## Rotate the filter kernel twice by 90 degrees to get 180 rotation
```

```
filter_kernel_flipped = np.rot90(filter_kernel,2)
```

```
## Pad the boundaries of the image with zeroes and fill the rest from the original image
```

```
image1 = np.zeros((9,9))
```

```
for i in xrange(row):
```

```
    for j in xrange(col):
```

```
        image1[i+1,j+1] = image[i,j]
```

```
print(image1)
```

```
## Define the output image
```

```
image_out = np.zeros((row,col))
```

```
## Dynamic shifting of the flipped filter at each image coordinate and then computing the
convolved sum.
```

```
for i in xrange(1,1+row):
```

```
    for j in xrange(1,1+col):
```

```
        arr_chunk = np.zeros((3,3))
```

```
        for k,k1 in zip(xrange(i-1,i+2),xrange(3)):
```

```
            for l,l1 in zip(xrange(j-1,j+2),xrange(3)):
```

```
                arr_chunk[k1,l1] = image1[k,l]
```

```
        image_out[i-1,j-1] = np.sum(np.multiply(arr_chunk,filter_kernel_flipped))
```

```
print(image_out)
```



```
[[ -2 -8 -7 -6 -5 -4 28]
 [  5 -3 -4 -5 -6 -7 28]
 [-2 -10 -11 -12 -13 -14 28]
 [-9 -17 -18 -19 -20 -21 28]
 [-16 -24 -25 -26 -27 -28 28]
 [-23 -31 -32 -33 -34 -35 28]
 [-29 13 13 13 13 13 27]]
```

Scipy convolve2d output

```
[[ -2. -8. -7. -6. -5. -4. 28.]
 [  5. -3. -4. -5. -6. -7. 28.]
 [-2. -10. -11. -12. -13. -14. 28.]
 [-9. -17. -18. -19. -20. -21. 28.]
 [-16. -24. -25. -26. -27. -28. 28.]
 [-23. -31. -32. -33. -34. -35. 28.]
 [-29. 13. 13. 13. 13. 13. 27.]]
```

2D convolution implementation

Figure 3-11.

Based on the choice of image-processing filter, the nature of the output images will vary. For example, a Gaussian filter would create an output image that would be a blurred version of the input image, whereas a Sobel filter would detect the edges in an image and produce an output image that contains the edges of the input image.

Common Image-Processing Filters

Let's discuss image-processing filters commonly used on 2D images. Make sure to be clear with notations since the natural way of indexing an image doesn't align well with how one would prefer to define the x and y axes. Whenever we represent an image-processing filter or an image in the coordinate space, n_1 and n_2 are the discrete coordinates for the x and y directions. The column index of the image in numpy matrix form coincides nicely with the x axis, whereas the row index moves in the opposite direction of the y axis. Also, it doesn't matter which pixel location one chooses as the origin for the image signal while doing convolution. Based on whether zero padding is used or not, one can handle the edges accordingly. Since the filter kernel is of a smaller size, we generally flip the filter kernel and then slide it over the image and not the other way around.

Mean Filter

The Mean filter or Average filter is a low-pass filter that computes the local average of the pixel intensities at any specific point. The impulse response of the Mean filter can be any of the form seen here (see Figure 3-12):

$$\begin{bmatrix} 1/9 & 1/9 & 1/9 \\ 1/9 & 1/9 & 1/9 \\ 1/9 & 1/9 & 1/9 \end{bmatrix}$$

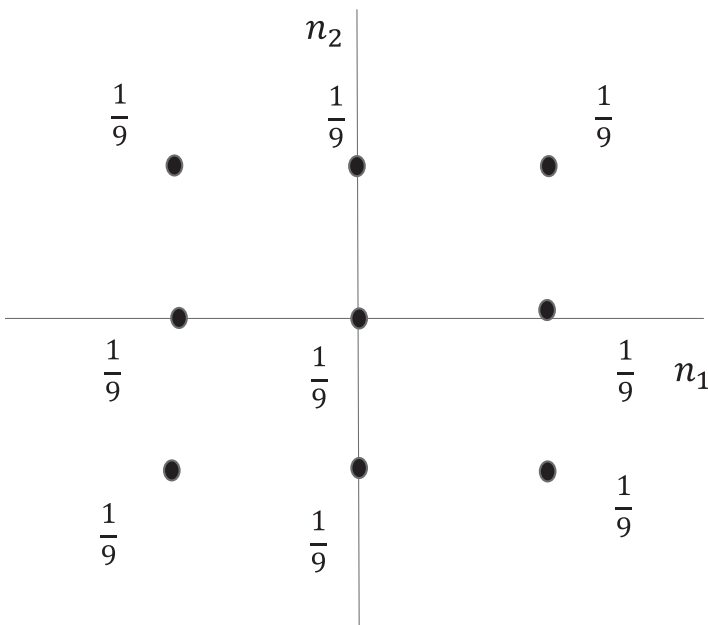

Figure 3-12. Impulse response of a Mean filter

Here, the matrix entry $h_{2,2}$ corresponds to the entry at the origin. So, at any given point, the convolution will represent the average of the pixel intensities at that point. The code in Listing 3-2 illustrates how one can convolve an image with an image-processing filter such as the Mean filter.

Please note that in many Python implementations we would be using OpenCV to perform basic operations on the image, such as reading the image, converting the image from RGB format to grayscale format, and so on. OpenCV is an open source image-processing package that has a rich set of methodologies for image processing. Readers are advised to explore OpenCV or any other image-processing toolbox in order to get accustomed to the basic image-processing functions.

Listing 3-2. Convolution of an Image with Mean Filter

```
import cv2
img = cv2.imread('monalisa.jpg')
gray = cv2.cvtColor(img, cv2.COLOR_BGR2GRAY)
plt.imshow(gray, cmap='gray')
mean = 0
var = 100
sigma = var**0.5
row,col = 650,442
gauss = np.random.normal(mean, sigma, (row,col))
gauss = gauss.reshape(row,col)
gray_noisy = gray + gauss
plt.imshow(gray_noisy, cmap='gray')
## Mean filter
Hm = np.array([[1,1,1],[1,1,1],[1,1,1]])/float(9)
Gm = convolve2d(gray_noisy,Hm,mode='same')
plt.imshow(Gm, cmap='gray')
```

In Listing 3-2, we read an image of the *Mona Lisa* and then introduce some Gaussian white noise into the image. The Gaussian noise has a mean of 0 and a variance of 100. We then convolve the noisy image with a Mean filter to reduce the white noise. The noisy image and the image after convolution has been plotted are shown in Figure 3-13.



Noisy Image with Gaussian Noise



Image after Convoluting with Mean Filter

Figure 3-13. Mean filter processing on Mona Lisa image

The Mean filter is mostly used to reduce the noise in an image. If there is some white Gaussian noise present in the image, then the Mean filter will reduce the noise since it averages over its neighborhood, and hence the white noise of the zero mean will be suppressed. As we can see from Figure 3-13, the Gaussian white noise is reduced once the image has been convolved with the Mean filter. The new image has fewer high-frequency components and thus is relatively less sharp than the image before convolution, but the filter has done a good job of reducing the white noise.

Median Filter

A 2D Median filter replaces each pixel in a neighborhood with the median pixel intensity in that neighborhood based on the filter size. The Median filter is good for removing salt and pepper noise. This type of noise presents itself in the images in the form of black and white pixels and is generally caused by sudden disturbances while capturing the images. Listing 3-3 illustrates how salt and pepper noise can be added to an image and then how the noise can be suppressed using a Median filter.

Listing 3-3.

```
## Generate random integers from 0 to 20
## If the value is zero we will replace the image pixel with a low value of 0 that
## corresponds to a black pixel
## If the value is 20 we will replace the image pixel with a high value of 255 that
## corresponds to a white pixel
## We have taken 20 integers, out of which we will only tag integers 1 and 20 as salt and
## pepper noise
## Hence, approximately 10% of the overall pixels are salt and pepper noise. If we want to
## reduce it
```

to 5% we can take integers from 0 to 40 and then treat 0 as an indicator for a black pixel and 40 as an indicator for a white pixel.

```
np.random.seed(0)
gray_sp = gray*1
sp_indices = np.random.randint(0,21,[row,col])
for i in xrange(row):
    for j in xrange(col):
        if sp_indices[i,j] == 0:
            gray_sp[i,j] = 0
        if sp_indices[i,j] == 20:
            gray_sp[i,j] = 255
plt.imshow(gray_sp,cmap='gray')
```

Now we want to remove the salt and pepper noise through a Median filter.
Using the opencv Median filter for the same

```
gray_sp_removed = cv2.medianBlur(gray_sp,3)
plt.imshow(gray_sp_removed,cmap='gray')
```

##Implementation of the 3x3 Median filter without using opencv

```
gray_sp_removed_exp = gray*1
for i in xrange(row):
    for j in xrange(col):
        local_arr = []
        for k in xrange(np.max([0,i-1]),np.min([i+2,row])):
            for l in xrange(np.max([0,j-1]),np.min([j+2,col])):
                local_arr.append(gray_sp[k,l])
        gray_sp_removed_exp[i,j] = np.median(local_arr)
plt.imshow(gray_sp_removed_exp,cmap='gray')
```

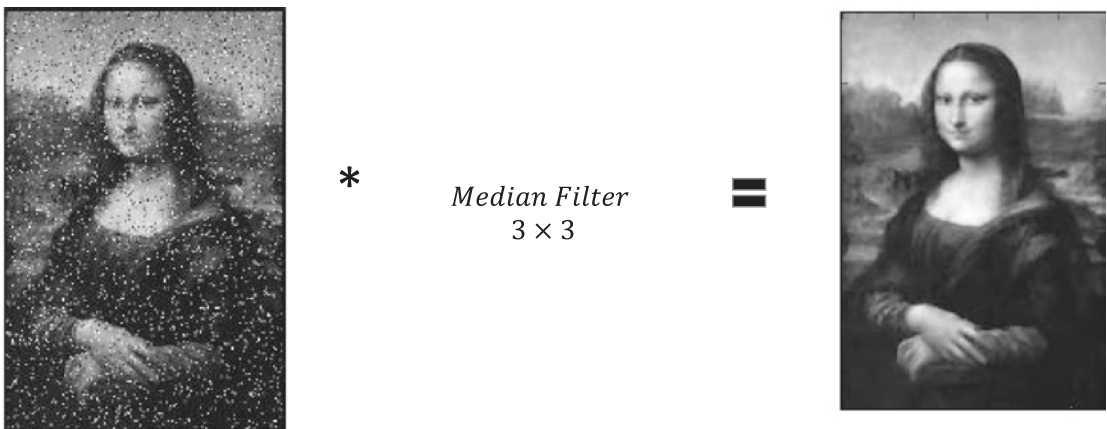

Figure 3-14. Median filter processing

As we can see, the salt and pepper noise has been removed by the Median filter.

Gaussian Filter

The Gaussian filter is a modified version of the Mean filter where the weights of the impulse function are distributed normally around the origin. Weight is highest at the center of the filter and falls normally away from the center. A Gaussian filter can be created with the code in Listing 3-4. As we can see, the intensity falls in a Gaussian fashion away from the origin. The Gaussian filter, when displayed as an image, has the highest intensity at the origin and then diminishes for pixels away from the center. Gaussian filters are used to reduce noise by suppressing the high-frequency components. However, in its pursuit of suppressing the high-frequency components it ends up producing a blurred image, called Gaussian blur.

In Figure 3-15, the original image is convolved with the Gaussian filter to produce an image that has Gaussian blur. We then subtract the blurred image from the original image to get the high-frequency component of the image. A small portion of the high-frequency image is added to the original image to improve the sharpness of the image.

Listing 3-4.

```
Hg = np.zeros((20,20))
for i in xrange(20):
    for j in xrange(20):
        Hg[i,j] = np.exp(-((i-10)**2 + (j-10)**2)/10)
plt.imshow(Hg,cmap='gray')
gray_blur = convolve2d(gray,Hg,mode='same')
plt.imshow(gray_blur,cmap='gray')
gray_enhanced = gray + 0.025*gray_high
plt.imshow(gray_enhanced,cmap='gray')
```

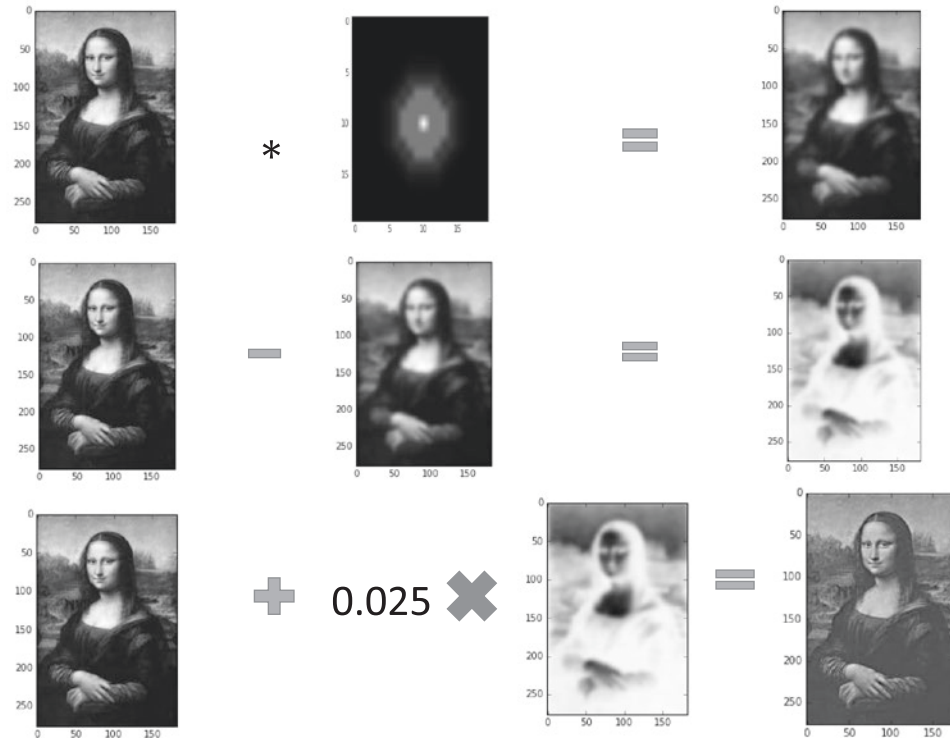

Figure 3-15. Various activities with Gaussian filter kernel

Gradient-based Filters

To review, the gradient of a two-dimensional function $I(x, y)$ is given by the following:

$$\nabla I(x, y) = \left[\frac{\partial I(x, y)}{\partial x} \quad \frac{\partial I(x, y)}{\partial y} \right]^T$$

where the gradient along the horizontal direction is given by -

$$\frac{\partial I(x, y)}{\partial x} = \lim_{h \rightarrow 0} \frac{I(x+h, y) - I(x, y)}{h} \text{ or } \lim_{h \rightarrow 0} \frac{I(x+h, y) - I(x-h, y)}{2h}$$

based on convenience and the problem

at hand.

For discrete coordinates, we can take $h=1$ and approximate the gradient along the horizontal as follows:

$$\frac{\partial I(x, y)}{\partial x} = I(x+1, y) - I(x, y)$$

This derivative of a signal can be achieved by convolving the signal with the filter kernel $\begin{bmatrix} 0 & 0 & 0 \\ 0 & 1 & -1 \\ 0 & 0 & 0 \end{bmatrix}$.

Similarly,

$$\frac{\partial I(x, y)}{\partial x} \propto I(x+1, y) - I(x-1, y)$$

from the second representation.

This form of derivative can be achieved by convolving the signal with the filter kernel $\begin{bmatrix} 0 & 0 & 0 \\ 1 & 0 & -1 \\ 0 & 0 & 0 \end{bmatrix}$.

For the vertical direction, the gradient component in the discrete case can be expressed as

$$\frac{\partial I(x, y)}{\partial y} = I(x, y+1) - I(x, y) \text{ or by } \frac{\partial I(x, y)}{\partial y} \propto I(x, y+1) - I(x, y-1)$$

The corresponding filter kernels to compute gradients through convolution are $\begin{bmatrix} 0 & -1 & 0 \\ 0 & 1 & 0 \\ 0 & 0 & 0 \end{bmatrix}$ and

$\begin{bmatrix} 0 & -1 & 0 \\ 0 & 0 & 0 \\ 0 & 1 & 0 \end{bmatrix}$ respectively.

Do note that these filters take the direction of the x axis and y axis, as shown in Figure 3-16. The direction of x agrees with the matrix index n_2 increment, whereas the direction of y is opposite to that of the matrix index n_1 increment.

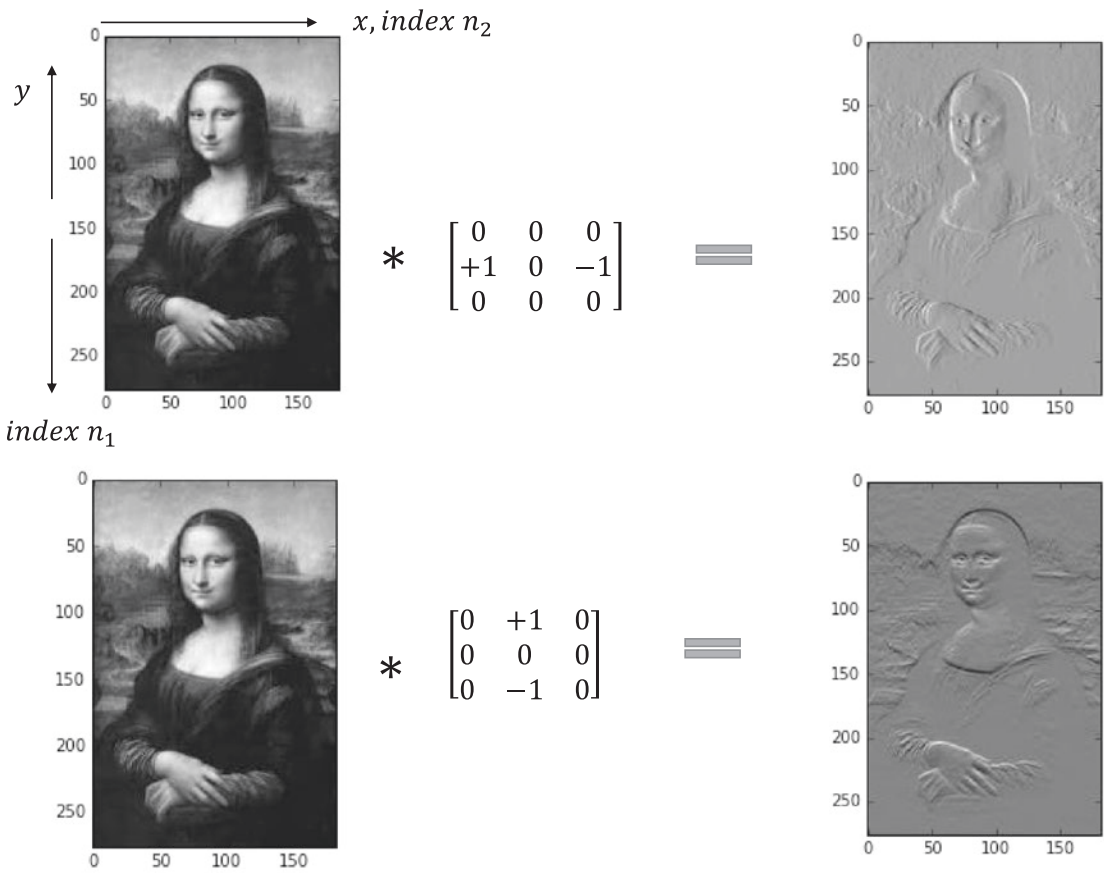

Figure 3-16. Vertical and horizontal gradient filters

Figure 3-16 illustrates the convolution of the *Mona Lisa* image with the Horizontal and Vertical Gradient filters.

Sobel Edge-Detection Filter

The impulse response of a Sobel Edge Detector along the horizontal and vertical axes can be expressed by the following H_x and H_y matrices respectively. The Sobel Detectors are extensions of the Horizontal and Vertical Gradient filters just illustrated. Instead of only taking the gradient at the point, it also takes the sum of the gradients at the points on either side of it. Also, it gives double weight to the point of interest. See Figure 3-17.

$$H_x = \begin{bmatrix} 1 & 0 & -1 \\ 2 & 0 & -2 \\ 1 & 0 & -1 \end{bmatrix} = \begin{bmatrix} 1 \\ 2 \\ 1 \end{bmatrix} \begin{bmatrix} 1 & 0 & -1 \end{bmatrix}$$

$$H_y = \begin{bmatrix} -1 & -2 & -1 \\ 0 & 0 & 0 \\ 1 & 2 & 1 \end{bmatrix}$$

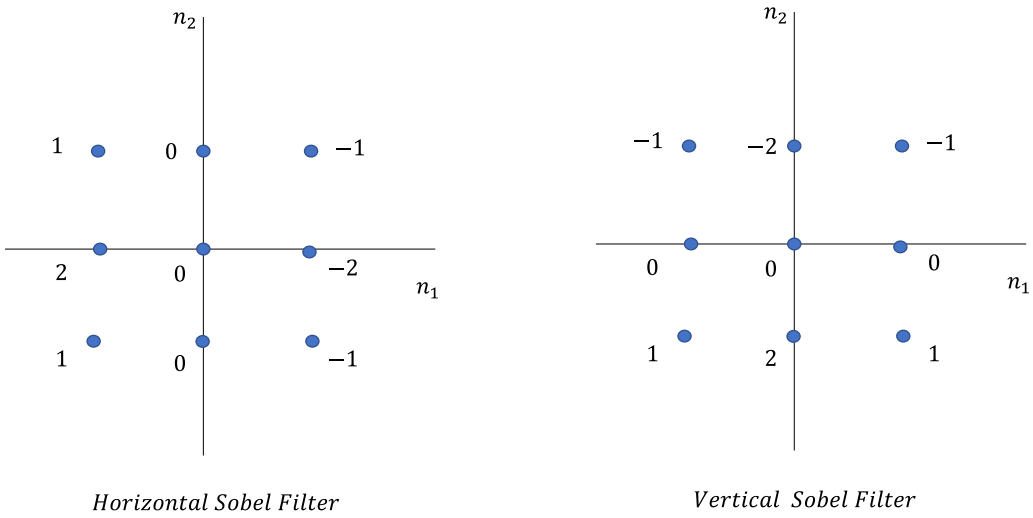

Figure 3-17. Sobel filter impulse response

The convolution of the image with the Sobel filters is illustrated in Listing 3-5.

Listing 3-5. Convolution Using a Sobel Filter

```
Hx = np.array([[ 1,0, -1],[2,0,-2],[1,0,-1]],dtype=np.float32)
Gx = convolve2d(gray,Hx,mode='same')
plt.imshow(Gx,cmap='gray')

Hy = np.array([[ -1,-2, -1],[0,0,0],[1,2,1]],dtype=np.float32)
Gy = convolve2d(gray,Hy,mode='same')
plt.imshow(Gy,cmap='gray')

G = (Gx*Gx + Gy*Gy)**0.5
plt.imshow(G,cmap='gray')
```

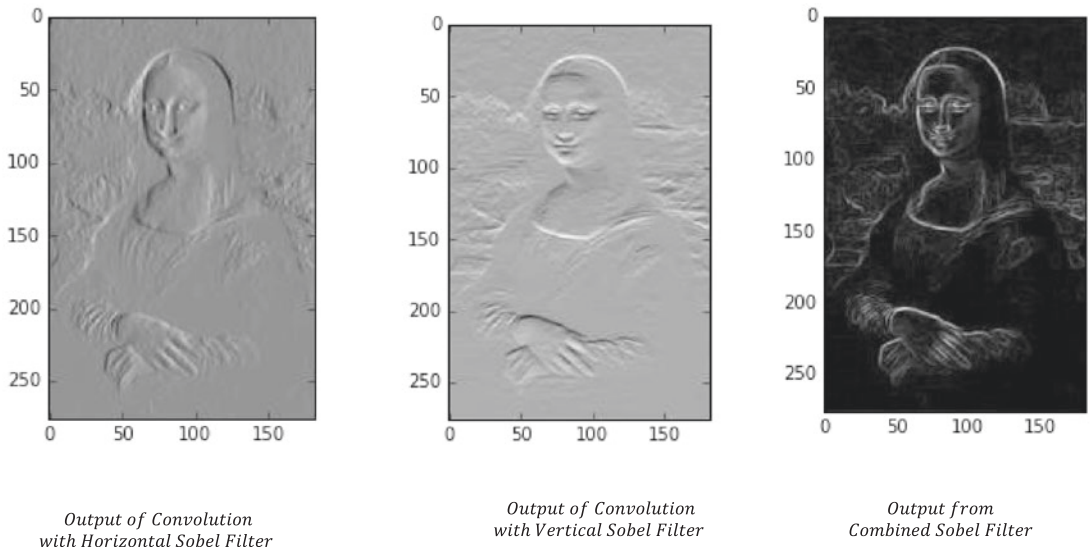



Figure 3-18. Output of various Sobel filters

Listing 3-5 has the logic required to convolve the image with the Sobel filters. The Horizontal Sobel filter detects edges in the horizontal direction, whereas the Vertical Sobel filter detects edges in the vertical direction. Both are high-pass filters since they attenuate the low frequencies from the signals and capture only the high-frequency components within the image. Edges are important features for an image and help one detect local changes within an image. Edges are generally present on the boundary between two regions in an image and are often the first step in retrieving information from images. We see the output of Listing 3-5 in Figure 3-18. The pixel values obtained for the images with Horizontal and Vertical Sobel filters for each location can be thought of as a vector $I'(x,y) = [I_x(x,y) I_y(x,y)]^T$, where $I_x(x,y)$ denotes the pixel intensity of the image obtained through the Horizontal Sobel filter and $I_y(x,y)$ denotes the pixel intensity of the image obtained through the Vertical Sobel filter. The magnitude of the vector $I'(x,y)$ can be used as the pixel intensity of the combined Sobel filter.

$C(x,y) = \sqrt{(I_x(x,y))^2 + (I_y(x,y))^2}$, where $C(x,y)$ denotes the pixel intensity function for the combined Sobel filter.

Identity Transform

The filter for Identity Transform through convolution is as follows:

$$\begin{bmatrix} 0 & 0 & 0 \\ 0 & 1 & 0 \\ 0 & 0 & 0 \end{bmatrix}$$

Figure 3-19 illustrates a Unity Transform through convolution.

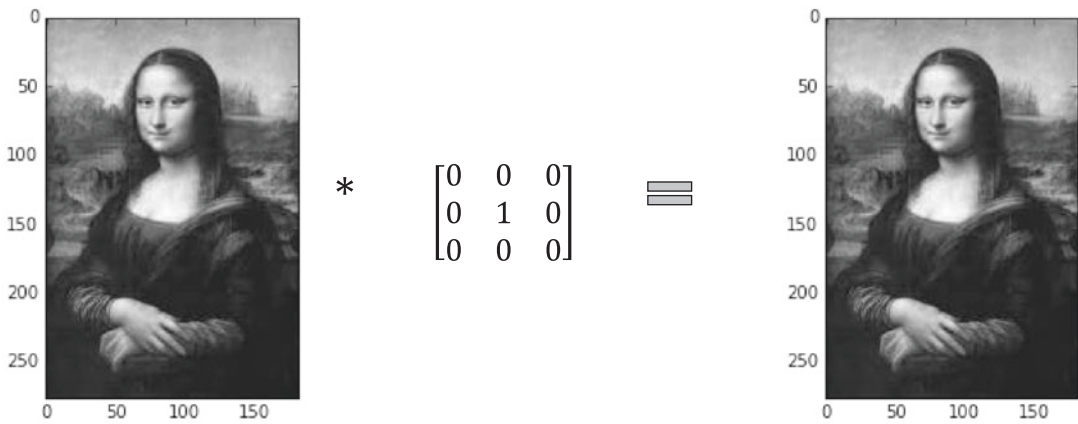

Figure 3-19. Identity transform through convolution

Table 3-1 lists several useful image-processing filters and their uses.

Table 3-1. Image-Processing Filters and Their Uses

Filter	Use
Mean Filter	Reduce Gaussian noise, smooth the image after upsampling
Median Filter	Reduce salt and pepper noise
Sobel Filter	Detect edges in an image
Gaussian Filter	Reduce noise in an image
Canny Filter	Detect edges in an image
Weiner Filter	Reduce additive noise and blurring

Convolution Neural Networks

Convolution neural networks (CNNs) are based on the convolution of images and detect features based on filters that are learned by the CNN through training. For example, we don't apply any known filter, such as the ones for the detection of edges or for removing the Gaussian noise, but through the training of the convolutional neural network the algorithm learns image-processing filters on its own that might be very different from normal image-processing filters. For supervised training, the filters are learned in such a way that the overall cost function is reduced as much as possible. Generally, the first convolution layer learns to detect edges, while the second may learn to detect more complex shapes that can be formed by combining different edges, such as circles and rectangles, and so on. The third layer and beyond learn much more complicated features based on the features generated in the previous layer.

The good thing about convolutional neural networks is the sparse connectivity that results from weight sharing, which greatly reduces the number of parameters to learn. The same filter can learn to detect the same edge in any given portion of the image through its equivariance property, which is a great property of convolution useful for feature detection.

Components of Convolution Neural Networks

The following are the typical components of a convolutional neural network:

Input layer will hold the pixel intensity of the image. For example, an input image with width 64, height 64, and depth 3 for the Red, Green, and Blue color channels (RGB) would have input dimensions of $64 \times 64 \times 3$.

Convolution layer will take images from the preceding layers and convolve with them the specified number of filters to create images called *output feature maps*. The number of output feature maps is equal to the specified number of filters. Till now, CNNs in TensorFlow have used mostly 2D filters; however, recently 3D convolution filters have been introduced.

Activation function for CNNs are generally ReLUs, which we discussed in Chapter 2. The output dimension is the same as the input after passing through the ReLU activation layers. The ReLU layer adds non-linearity in the network and at the same time provides non-saturating gradients for positive net inputs.

Pooling layer will downsample the 2D activation maps along the height and width dimensions. The depth or the number of activation maps is not compromised and remains the same.

Fully connected layers contain traditional neurons that receive different sets of weights from the preceding layers; there is no weight sharing between them as is typical for convolution operations. Each neuron in this layer will be connected either to all the neurons in the previous layer or to all the coordinate-wise outputs in the output maps through separate weights. For classification, the class output neurons receive inputs from the final fully connected layers.

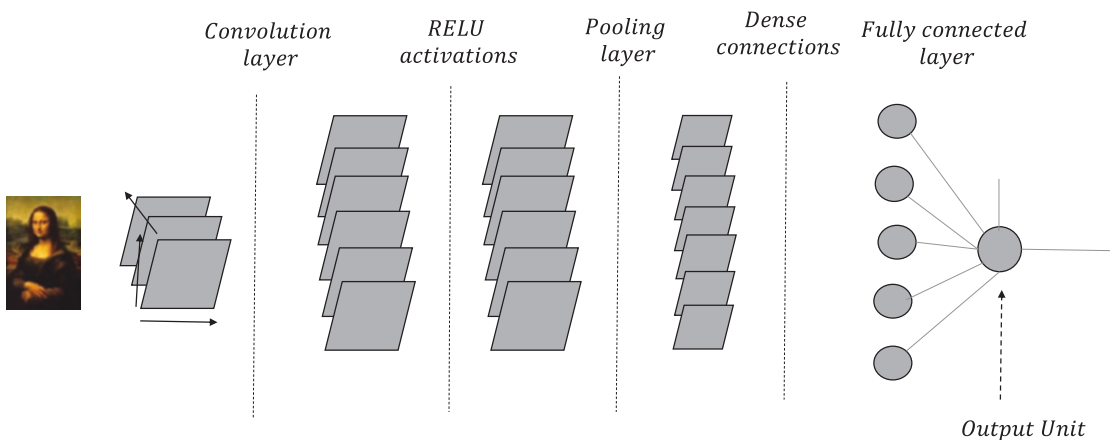

Figure 3-20. Basic flow diagram of a convolutional neural network

Figure 3-20 illustrates a basic convolutional neural network (CNN) that uses one convolutional layer, one ReLU layer, and one pooling layer followed by a fully connected layer and finally the output classification layer. The network tries to discern the *Mona Lisa* images from the non-*Mona Lisa* images. The output unit can be taken to have a sigmoid activation function since it's a binary classification problem for

images. Generally, for most of the CNN architectures a few to several convolutional layer-ReLU layer-pooling layer combinations are stacked one after another before the fully connected layers. We will discuss the different architectures at a later point in time. For now, let's look at the different layers in much more detail.

Input Layer

The input to this layer are images. Generally, the images are fed in batches as four-dimensional tensors where the first dimension is specific to the image index, second and third dimensions are specific to the height and width of the image, and the fourth dimension corresponds to the different channels. For a colored image, generally we have the Red (R), Green (G), and Blue (B) channels, while for grayscale images we have only one channel. The number of images in a batch would be determined by the mini-batch size chosen for the mini-batch stochastic gradient descent. The batch size is one for stochastic gradient descent.

The inputs can be fed to the input layer in mini batches through TensorFlow placeholder `tf.placeholder` at runtime.

Convolution Layer

Convolution is the heart of any CNN network. TensorFlow supports both 2D and 3D convolutions. However, 2D convolutions are more common since 3D convolutions are computationally memory intensive. The input images or intermediate images in the form of output feature maps are 2D convolved with 2D filters of the size specified. 2D convolution happens along the spatial dimensions, while there is no convolution along the depth channel of the image volume. For each depth channel, the same number of feature maps are generated, and then they are summed together along the depth dimension before they pass through the ReLU activations. These filters help to detect features in the images. The deeper the convolutional layer is in the network, the more complicated features it learns. For instance, the initial convolutional layer might learn to detect edges in an image, while the second convolutional layer might learn to connect the edges to form geometric shapes such as circles and rectangles. The even deeper convolutional layers might learn to detect more complicated features; for example, in Cat versus Dog classification it might learn to detect eyes, nose, or other body parts of the animals.

In a CNN, only the size of the filters is specified; the weights are initialized to arbitrary values before the start of training. The weights of the filters are learned through the CNN training process and hence they might not represent the traditional image-processing filters such as Sobel, Gaussian, Mean, Median, or other kind of filters. Instead the learned filters would be such that the overall loss function defined is minimized or a good generalization is achieved based on the validation. Although it might not learn the traditional edge-detection filter, it would learn several filters that detect edges in some form since edges are good feature detectors for images.

Some of the terms with which one should be familiar while defining the convolution layer are as follows:

Filter size – Filter size defines the height and width of the filter kernel. A filter kernel of size 3×3 would have nine weights. Generally, these filters are initialized and slid over the input image for convolution without flipping these filters. Technically, when convolution is performed without flipping the filter kernel it's called cross-correlation and not convolution. However, it doesn't matter, as we can consider the filters learned as a flipped version of image-processing filters.

Stride – The stride determines the number of pixels to move in each spatial direction while performing convolution. In normal convolution of signals, we generally don't skip any pixels and instead compute the convolution sum at each pixel location, and hence we have a stride of 1 along both spatial directions for 2D signals. However, one may choose to skip every alternate pixel location while

convolving and thus chose a stride of 2. If a stride of 2 is chosen along both the height and the width of the image, then after convolving the output image would be approximately $\frac{1}{4}$ of the input image size. Why it is *approximately* $\frac{1}{4}$ and not *exactly* $\frac{1}{4}$ of the original image or feature-map size will be covered in our next topic of discussion.

Padding - When we convolve an image of a specific size by a filter, the resulting image is generally smaller than the original image. For example, if we convolve a 5×5 2D image by a filter of size 3×3 , the resulting image is 3×3 .

Padding is an approach that appends zeroes to the boundary of an image to control the size of the output of convolution. The convolved output image length L' along a specific spatial dimension is given by

$$L' = \frac{L - K + 2P}{S} + 1$$

where

$L \rightarrow$ Length of the input image in a specific dimension

$K \rightarrow$ Length of the kernel/filter in a specific dimension

$P \rightarrow$ Zeroes padded along a dimension in either end

$S \rightarrow$ Stride of the convolution

In general, for a stride of 1 the image size along each dimension is reduced by $(K-1)/2$ on either end, where K is the length of the filter kernel along that dimension. So, to keep the output image the same as that of the input image, a pad length of $\frac{K-1}{2}$ would be required.

Whether a specific stride size is possible can be found out from the output image length along a specific direction. For example, if $L=12$, $K=3$, and $P=0$, stride $S=2$ is not possible, since it would produce an output length along the spatial dimension as $\frac{(12-3)}{2} = 4.5$, which is not an integer value.

In TensorFlow, padding can be chosen as either "VALID" or "SAME". "SAME" ensures that the output spatial dimensions of the image are the same as those of the input spatial dimensions in cases where a stride of 1 is chosen. It uses zero padding to achieve this. It tries to keep the zero-pad length even on both sides of a dimension, but if the total pad length for that dimension is odd then the extra length is added to the right for the horizontal dimension and to the bottom for the vertical dimension.

"VALID" doesn't use zero padding and hence the output image dimension would be smaller than the input image dimensions, even for a stride of 1.

TensorFlow Usage

```
def conv2d(x,W,b,strides=1):
    x = tf.nn.conv2d(x,W,strides=[1,strides,strides,1],padding='SAME')
    x = tf.nn.bias_add(x,b)
    return tf.nn.relu(x)
```

For defining a TensorFlow Convolutional layer we use `tf.nn.conv2d` where we need to define the input to the Convolution, weights associated with the Convolution, the stride size and the padding type. Also, we add a bias for each output feature map. Finally, we use the Rectified Linear Units ReLUs as activations to add non-linearity into the system.

Pooling Layer

A pooling operation on an image generally summarizes a locality of an image, the locality being given by the size of the filter kernel, also called the receptive field. The summarization generally happens in the form of max pooling or average pooling. In max pooling, the maximum pixel intensity of a locality is taken as the representative of that locality. In average pooling, the average of the pixel intensities around a locality is taken as the representative of that locality. Pooling reduces the spatial dimensions of an image. The kernel size that determines the locality is generally chosen as 2×2 whereas the stride is chosen as 2. This reduces the image size to about $\frac{1}{4}$ the size of the original image.

TensorFlow Usage

```
''' POOLING LAYER'''
def maxpool2d(x, stride=2):
    return tf.nn.max_pool(x, ksize=[1, stride, stride, 1], strides=[1, stride, stride, 1],
        padding='SAME')
```

The `tf.nn.max_pool` definition is used to define a max pooling layer while `tf.nn.avg_pool` is used to define an average pooling layer. Apart from the input, we need to input the receptive field or kernel size of max pooling through the `ksize` parameter. Also, we need to provide the strides to be used for the max pooling. To ensure that the values in each spatial location of the output feature map from pooling are from independent neighborhoods in the input, the stride in each spatial dimension should be chosen to be equal to the kernel size in the corresponding spatial dimension.

Backpropagation Through the Convolutional Layer

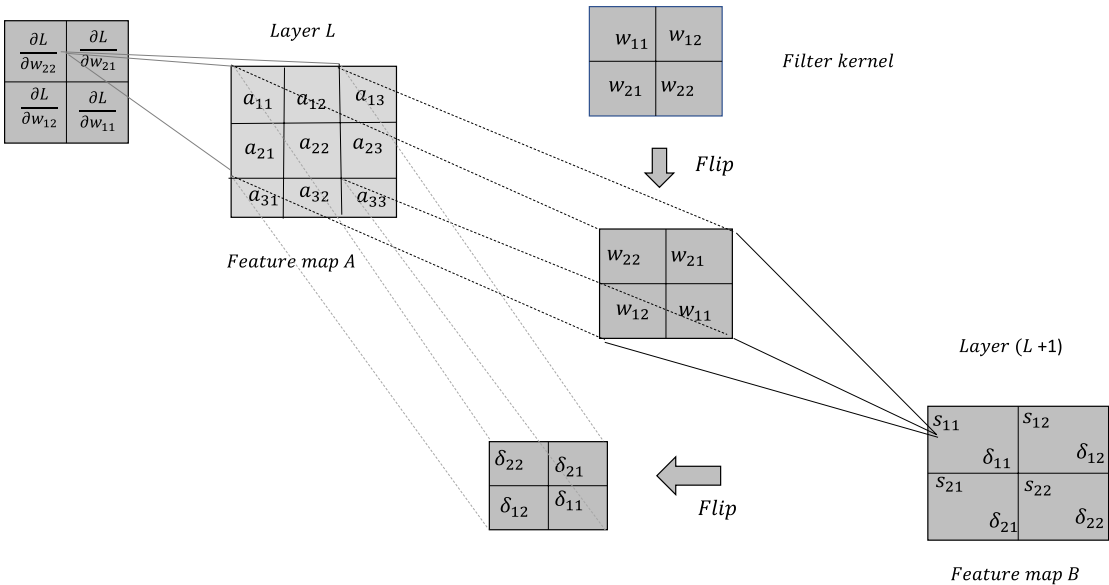

Figure 3-21. Backpropagation through the convolutional layer

Backpropagation through a convolution layer is much like backpropagation for a multi-layer Perceptron network. The only difference is that the weight connections are sparse since the same weights are shared by different input neighborhoods to create an output feature map. Each output feature map is the result of the convolution of an image or a feature map from the previous layer with a filter kernel whose values are the weights that we need to learn through backpropagation. The weights in the filter kernel are shared for a specific input-output feature-map combination.

In Figure 3-21, feature map A in layer L convolves with a filter kernel to produce an output feature map B in layer $(L+1)$.

The values of the output feature map are the results of convolution and can be expressed as $s_{ij} \forall i, j \in \{1, 2\}$:

$$\begin{aligned} s_{11} &= w_{22} * a_{11} + w_{21} * a_{12} + w_{12} * a_{21} + w_{11} * a_{22} \\ s_{12} &= w_{22} * a_{12} + w_{21} * a_{13} + w_{12} * a_{22} + w_{11} * a_{23} \\ s_{21} &= w_{22} * a_{21} + w_{21} * a_{22} + w_{12} * a_{31} + w_{11} * a_{32} \\ s_{22} &= w_{22} * a_{22} + w_{23} * a_{22} + w_{12} * a_{32} + w_{11} * a_{33} \end{aligned}$$

In generalized way:

$$s_{ij} = \sum_{n=1}^2 \sum_{m=1}^2 w_{(3-m)(3-n)} * a_{(i-1+m)(j-1+n)}$$

Now, let the gradient of the cost function L with respect to the net input s_{ij} be denoted by

$$\frac{\partial L}{\partial s_{ij}} = \delta_{ij}$$

Let's compute the gradient of the cost function with respect to the weight w_{22} . The weight is associated with all s_{ij} and hence would have gradient components from all the δ_{ij} :

$$\begin{aligned} \frac{\partial L}{\partial w_{22}} &= \sum_{j=1}^2 \sum_{i=1}^2 \frac{\partial L}{\partial s_{ij}} \frac{\partial s_{ij}}{\partial w_{22}} \\ &= \sum_{j=1}^2 \sum_{i=1}^2 \delta_{ij} \frac{\partial s_{ij}}{\partial w_{22}} \end{aligned}$$

Also, from the preceding equations for different s_{ij} , the following can be derived:

$$\frac{\partial s_{11}}{\partial w_{22}} = a_{11}, \quad \frac{\partial s_{12}}{\partial w_{22}} = a_{12}, \quad \frac{\partial s_{13}}{\partial w_{22}} = a_{21}, \quad \frac{\partial s_{14}}{\partial w_{22}} = a_{22}$$

Hence,

$$\frac{\partial L}{\partial w_{22}} = \delta_{11} * a_{11} + \delta_{12} * a_{12} + \delta_{21} * a_{21} + \delta_{22} * a_{22}$$

Similarly,

$$\begin{aligned}\frac{\partial L}{\partial w_{21}} &= \sum_{j=1}^2 \sum_{i=1}^2 \frac{\partial L}{\partial s_{ij}} \frac{\partial s_{ij}}{\partial w_{21}} \\ &= \sum_{j=1}^2 \sum_{i=1}^2 \delta_{ij} \frac{\partial s_{ij}}{\partial w_{21}}\end{aligned}$$

$$\text{Again, } \frac{\partial s_{11}}{\partial w_{21}} = a_{12}, \quad \frac{\partial s_{12}}{\partial w_{21}} = a_{13}, \quad \frac{\partial s_{21}}{\partial w_{21}} = a_{22}, \quad \frac{\partial s_{22}}{\partial w_{21}} = a_{23}$$

Hence,

$$\frac{\partial L}{\partial w_{21}} = \delta_{11} * a_{12} + \delta_{12} * a_{13} + \delta_{21} * a_{22} + \delta_{22} * a_{23}$$

Proceeding by the same approach for the other two weights, we get

$$\begin{aligned}\frac{\partial L}{\partial w_{11}} &= \sum_{j=1}^2 \sum_{i=1}^2 \frac{\partial L}{\partial s_{ij}} \frac{\partial s_{ij}}{\partial w_{11}} \\ &= \sum_{j=1}^2 \sum_{i=1}^2 \delta_{ij} \frac{\partial s_{ij}}{\partial w_{11}}\end{aligned}$$

$$\frac{\partial s_{11}}{\partial w_{11}} = a_{22}, \quad \frac{\partial s_{12}}{\partial w_{11}} = a_{23}, \quad \frac{\partial s_{21}}{\partial w_{11}} = a_{32}, \quad \frac{\partial s_{22}}{\partial w_{11}} = a_{33}$$

$$\frac{\partial L}{\partial w_{11}} = \delta_{11} * a_{22} + \delta_{12} * a_{23} + \delta_{21} * a_{32} + \delta_{22} * a_{33}$$

$$\frac{\partial L}{\partial w_{12}} = \sum_{j=1}^2 \sum_{i=1}^2 \frac{\partial L}{\partial s_{ij}} \frac{\partial s_{ij}}{\partial w_{12}}$$

$$\frac{\partial s_{11}}{\partial w_{12}} = a_{21}, \quad \frac{\partial s_{12}}{\partial w_{12}} = a_{22}, \quad \frac{\partial s_{21}}{\partial w_{12}} = a_{31}, \quad \frac{\partial s_{22}}{\partial w_{12}} = a_{32}$$

$$\frac{\partial L}{\partial w_{12}} = \delta_{11} * a_{21} + \delta_{12} * a_{22} + \delta_{21} * a_{31} + \delta_{22} * a_{32}$$

Based on the preceding gradients of the cost function L with respect to the four weights of the filter kernel, we get the following relationship:

$$\frac{\partial L}{\partial w_{ij}} = \sum_{n=1}^2 \sum_{m=1}^2 \delta_{nm} * a_{(i-1+m)(j-1+n)}$$

When arranged in matrix form, we get the following relationship; (x) denotes the cross-correlation:

$$\begin{bmatrix} \frac{\partial L}{\partial w_{22}} & \frac{\partial L}{\partial w_{21}} \\ \frac{\partial L}{\partial w_{12}} & \frac{\partial L}{\partial w_{11}} \end{bmatrix} = \begin{bmatrix} a_{11} & a_{12} & a_{13} \\ a_{21} & a_{22} & a_{23} \\ a_{31} & a_{32} & a_{33} \end{bmatrix} (x) \begin{bmatrix} \delta_{11} & \delta_{12} \\ \delta_{21} & \delta_{22} \end{bmatrix}$$

The cross correlation of $\begin{bmatrix} a_{11} & a_{12} & a_{13} \\ a_{21} & a_{22} & a_{23} \\ a_{31} & a_{32} & a_{33} \end{bmatrix}$ with $\begin{bmatrix} \delta_{11} & \delta_{12} \\ \delta_{21} & \delta_{22} \end{bmatrix}$ can also be thought of as the convolution of $\begin{bmatrix} a_{11} & a_{12} & a_{13} \\ a_{21} & a_{22} & a_{23} \\ a_{31} & a_{32} & a_{33} \end{bmatrix}$ with flipped $\begin{bmatrix} \delta_{11} & \delta_{12} \\ \delta_{21} & \delta_{22} \end{bmatrix}$; i.e., $\begin{bmatrix} \delta_{22} & \delta_{21} \\ \delta_{12} & \delta_{11} \end{bmatrix}$.

Hence, the flip of the gradient matrix is the convolution of $\begin{bmatrix} a_{11} & a_{12} & a_{13} \\ a_{21} & a_{22} & a_{23} \\ a_{31} & a_{32} & a_{33} \end{bmatrix}$ with $\begin{bmatrix} \delta_{22} & \delta_{21} \\ \delta_{12} & \delta_{11} \end{bmatrix}$; i.e.,

$$\begin{bmatrix} \frac{\partial L}{\partial w_{22}} & \frac{\partial L}{\partial w_{21}} \\ \frac{\partial L}{\partial w_{12}} & \frac{\partial L}{\partial w_{11}} \end{bmatrix} = \begin{bmatrix} a_{11} & a_{12} & a_{13} \\ a_{21} & a_{22} & a_{23} \\ a_{31} & a_{32} & a_{33} \end{bmatrix} (*) \begin{bmatrix} \delta_{22} & \delta_{12} \\ \delta_{21} & \delta_{11} \end{bmatrix}$$

In terms of the layers, one can say the flip of the gradient matrix turns out to be a cross-correlation of the gradient at the $(L+1)$ layer with the outputs of the feature map at layer L . Also, equivalently, the flip of the gradient matrix turns out to be a convolution of the flip of the gradient matrix at the $(L+1)$ layer with the outputs of the feature map at layer L .

Backpropagation Through the Pooling Layers

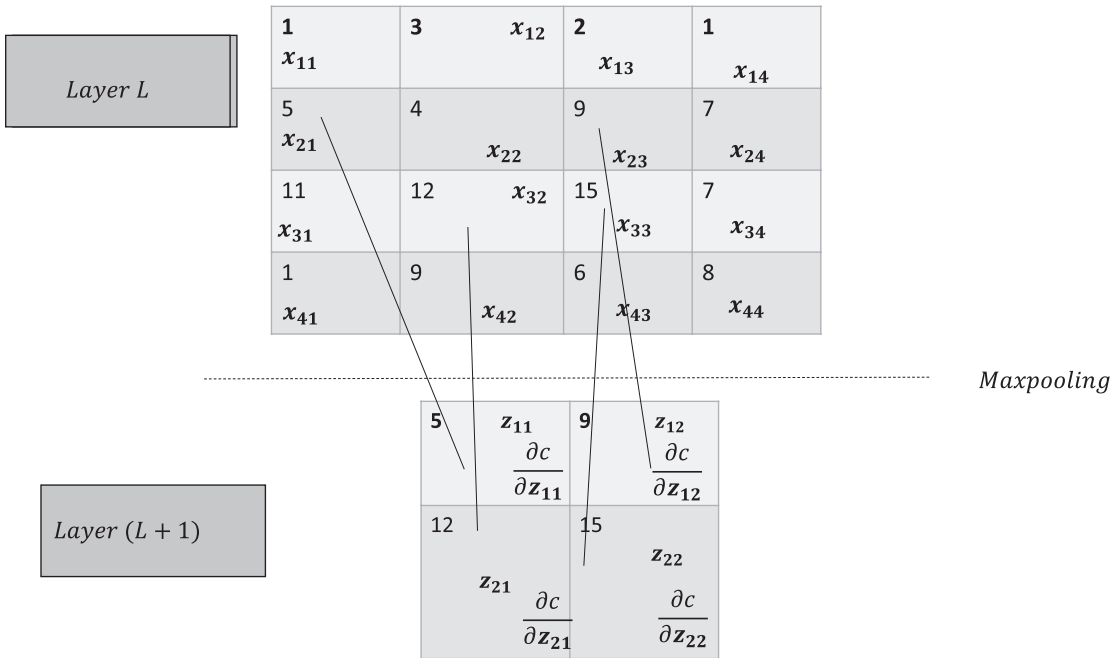

Figure 3-22. Backpropagation through max pooling layer

Figure 3-22 illustrates the max pooling operation. Let a feature map, after going through convolution and ReLU activations at layer L , go through the max pooling operation at layer $(L + 1)$ to produce the output feature map. The kernel or receptive field for max pooling is of size 2×2 , and the stride size is 2. The output of the max pooling layer is $\frac{1}{4}$ the size of the input feature map, and its output values are represented by $z_{ij}, \forall i, j \in \{1, 2\}$.

We can see z_{11} gets the value of 5 since the maximum in the 2×2 block is 5. If the error derivative at z_{11} is $\frac{\partial C}{\partial z_{11}}$, then the whole gradient is passed onto x_{21} with a value of 5, and the rest of the elements in its block— $x_{11}, x_{12},$ and x_{22} —receive zero gradients from z_{11} .

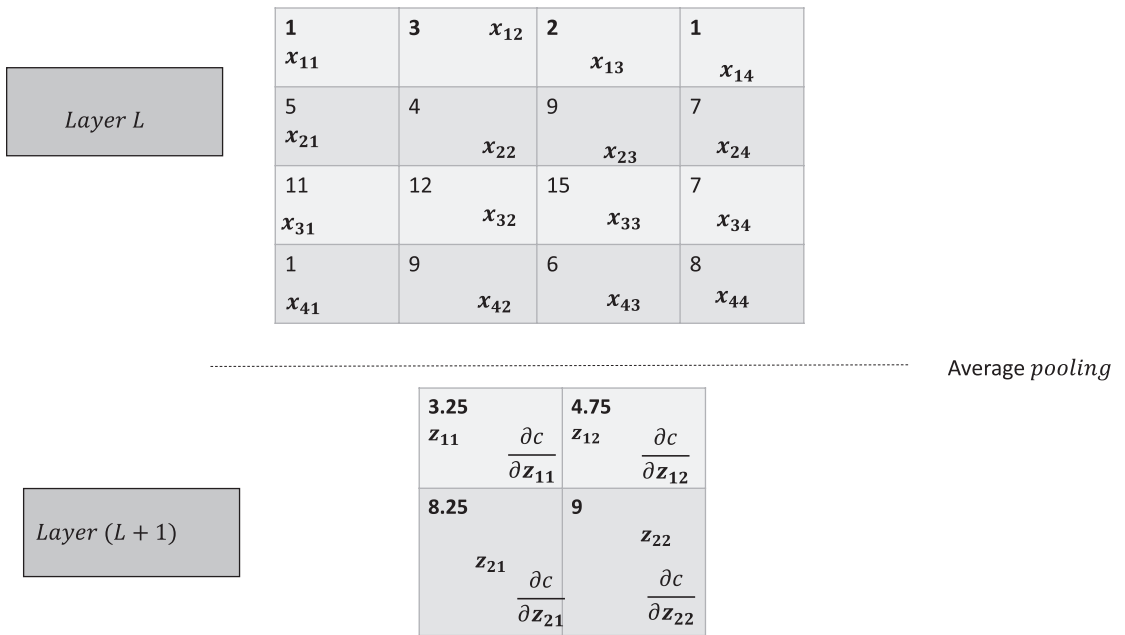

Figure 3-23. Backpropagation through average pooling layer

To use average pooling for the same example, the output is the average of the values in the 2×2 block of the input. Therefore, z_{11} gets the average of the values x_{11}, x_{12}, x_{21} , and x_{22} . Here, the error gradient $\frac{\partial C}{\partial z_{11}}$ at z_{11} would be shared equally by x_{11}, x_{12}, x_{21} , and x_{22} . Hence,

$$\frac{\partial C}{\partial x_{11}} = \frac{\partial C}{\partial x_{12}} = \frac{\partial C}{\partial x_{21}} = \frac{\partial C}{\partial x_{22}} = \frac{1}{4} \frac{\partial C}{\partial z_{11}}$$

Weight Sharing Through Convolution and Its Advantages

Weight sharing through convolution greatly reduces the number of parameters in the convolutional neural network. Imagine we created a feature map of size $k \times k$ from an image of $n \times n$ size with full connections instead of convolutions. There would be $k^2 n^2$ weights for that one feature map alone, which is a lot of weights to learn. Instead, since in convolution the same weights are shared across locations defined by the filter-kernel size, the number of parameters to learn is reduced by a huge factor. In cases of convolution, as in this scenario, we just need to learn the weights for the specific filter kernel. Since the filter size is relatively small with respect to the image, the number of weights is reduced significantly. For any image, we generate several feature maps corresponding to different filter kernels. Each filter kernel learns to detect a different kind of feature. The feature maps created are again convolved with other filter kernels to learn even more complex features in subsequent layers.

Translation Equivariance

The convolution operation provides translational equivariance. That is, if a feature A in an input produces a specific feature B in the output, then even if feature A is translated around in the image, feature B would continue to be generated at different locations of the output.

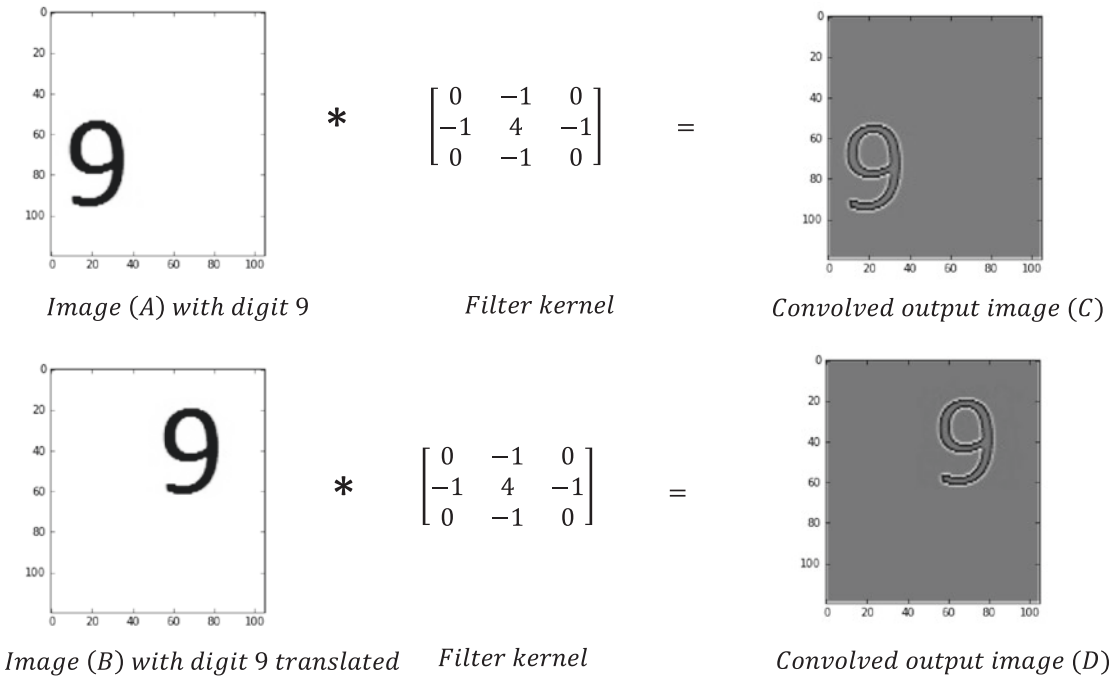

Figure 3-24. Translational equivariance illustration

In Figure 3-24 we can see that the digit 9 has been translated in Image (B) from its position in Image (A). Both the input images (A) and (B) have been convolved with the same filter kernel, and the same feature has been detected for the digit 9 in both output images (C) and (D) at different locations based on its location in the input. Convolution still produced the same feature for the digit irrespective of the translation. This property of convolution is called *translational equivariance*. In fact, if the digit is represented by a set of pixel intensities x , and f is the translation operation on x , while g is the convolution operation with a filter kernel, then the following holds true for convolution:

$$g(f(x)) = f(g(x))$$

In our case, $f(x)$ produces the translated 9 in Image (B) and the translated 9 is convolved through g to produce the activated feature for 9 in Image (D). This activated feature for 9 in Image (D) (i.e., $g(f(x))$) could also have been achieved by translating the activated 9 in Image (C) (i.e., $g(x)$) through the same translation f .

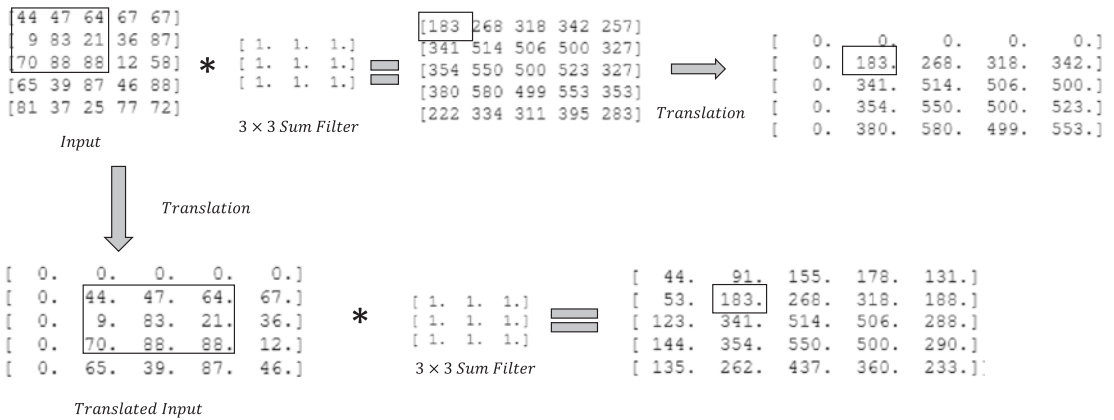

Figure 3-25. Illustration of equivariance with an example

It’s a little easier to see equivariance with a small example, as illustrated in Figure 3-25. The part of the

input image or 2D signal we are interested in is the left topmost block; i.e., $\begin{bmatrix} 44 & 47 & 64 \\ 9 & 83 & 21 \\ 70 & 88 & 88 \end{bmatrix}$. For easy

reference, let’s name the block A.

On convolving the input with the sum filter—i.e., $\begin{bmatrix} 1 & 1 & 1 \\ 1 & 1 & 1 \\ 1 & 1 & 1 \end{bmatrix}$ —block A would correspond to an output

value of 183, which could be treated as the feature detector for A.

On convolving the same sum filter with the translated image, the shifted block A would still produce an output value of 183. Also, we can see that if we were to apply the same translation to the original convoluted image output, the value of 183 would appear at the same location as that of the output of the convoluted image after translation.

Translation Invariance Due to Pooling

Pooling provides some form of translational invariance based on the receptor field kernel size of the pooling. Let’s take the case of max pooling, as illustrated in Figure 3-26. The digit in image A at a specific position is detected through a convolution filter H in the form of values 100 and 80 in the output feature map P . Also, the same digit appears in another image B in a slightly translated position with respect to image A. On convolving image B with filter H , the digit 9 is detected in the form of the same values of 100 and 80 in the feature map P' , but at a slightly displaced position from the one in. When these feature maps pass through the receptor field kernels of size 2×2 with stride 2 because of max pooling, the 100 and 80 values appear at the same location in both the output M and M' . In this way, max pooling provides some translational invariance to feature detection if the translation distance is not very high with respect to the size of the receptor field or kernel for max pooling.

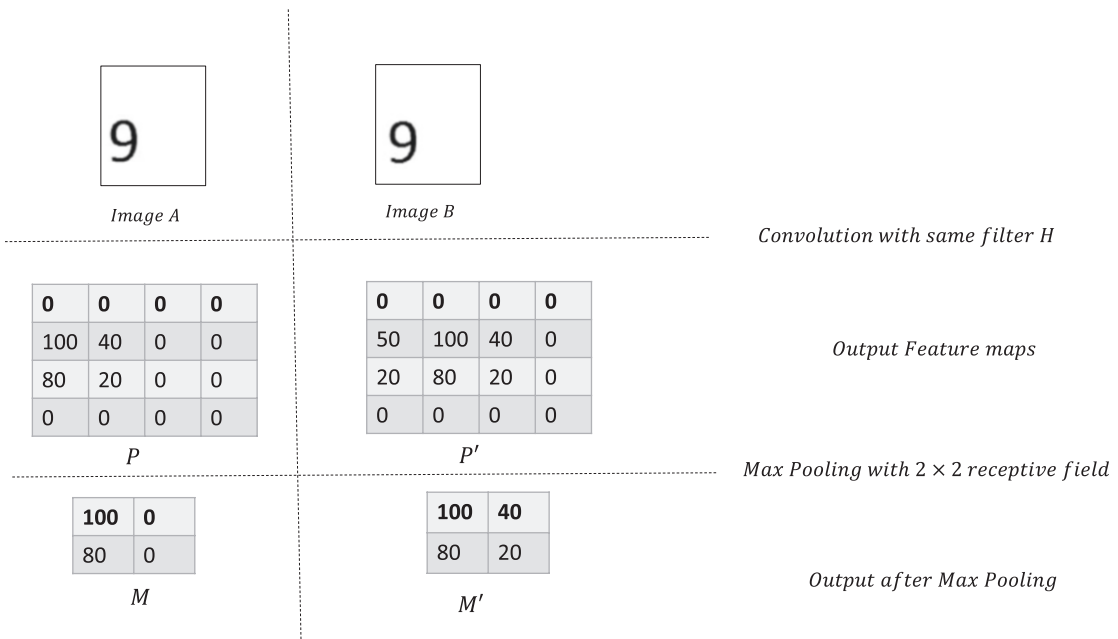

Figure 3-26. Translational invariance through max pooling

Similarly, average pooling takes the average of the values in a locality of a feature map based on the size of the receptor field kernel. So, if a specific feature is detected by high values in its feature map in a locality—let’s say at regions of edges—then the averages would continue to be high even if the image were a little translated.

Dropout Layers and Regularization

Dropout is an activity to regularize weights in the fully connected layers of a convolutional neural network to avoid overfitting. However, it is not restricted to convolutional neural networks, but rather applies to all feed-forward neural networks. A specified proportion of neural network units, both hidden and visible, is randomly dropped at training time for each training sample in a mini batch so that the remaining neurons can learn important features all by themselves and not rely on cooperation from other neurons. When the neurons are dropped randomly, all the incoming and outgoing connections to those neurons are also dropped. Too much cooperation between neurons makes the neurons dependent on each other and they fail to learn distinct features. This high cooperation leads to overfitting since it does well on the training dataset, while if the test dataset is somewhat different from the training dataset the predictions on test dataset go haywire.

When the neuron units are dropped randomly, each such setting of remaining available neurons produces a different network. Let’s suppose we have a network with N neural units; the number of possible neural network configuration possible is N^2 . For each training sample in a mini batch, a different set of neurons is chosen at random based on the dropout probability. So, training a neural network with dropout is equivalent to training a set of different neural networks where each network very seldom gets trained, if at all.

As we can surmise, averaging the predictions from many different models reduces the variances of the ensemble model and reduces overfitting, and so we generally get better, more stable predictions.

For two class problem, trained on two different models M_1 and M_2 , if the class probabilities for a datapoint are p_{11} and p_{12} for Model M_1 and p_{21} and p_{22} for Model M_2 , then we take the average probability for the ensemble model of M_1 and M_2 . The ensemble model would have a probability of $\frac{(p_{11} + p_{21})}{2}$ for Class 1 and $\frac{(p_{12} + p_{22})}{2}$ for Class 2.

Another averaging method would be to take the geometric mean of the predictions from different models. In this case, we would need to normalize over the geometric means to get the sum of new probabilities as 1.

The new probabilities for the ensemble model for the preceding example would be $\frac{\sqrt{p_{11} \times p_{21}}}{\sqrt{p_{11} \times p_{21}} + \sqrt{p_{12} \times p_{22}}}$ and $\frac{\sqrt{p_{12} \times p_{22}}}{\sqrt{p_{11} \times p_{21}} + \sqrt{p_{12} \times p_{22}}}$ respectively.

At test time, it is not possible to compute the predictions from all such possible networks and then average it out. Instead, the single neural network with all the weights and connections is used—but with weight adjustments. If a neural network unit is retained with probability p during training, then the outgoing weights from that unit are scaled down by multiplying the weights by probability p . In general, this approximation for prediction on test datasets works well. It can be proved that for a model with a SoftMax output layer, the preceding arrangement is equivalent to taking predictions out of those individual models resulting from dropout and then computing their geometric mean.

In Figure 3-27, a neural network whose three units have been dropped randomly is presented. As we can see, all the input and output connections of the dropped units have also been dropped.

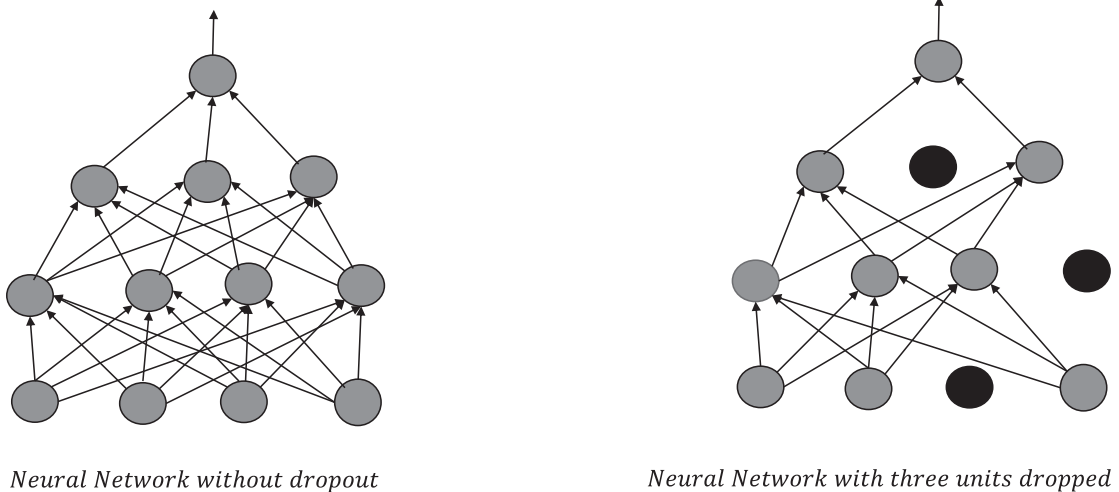

Figure 3-27. Neural network with three units dropped randomly

For a convolutional neural network, the units in the fully connected layers and their corresponding incoming and outgoing connections are usually dropped. Hence, the different filter-kernel weights do not require any adjustment while predicting for the test dataset.

Convolutional Neural Network for Digit Recognition on the MNIST Dataset

Now that we have gone through the basic building blocks for a convolutional neural network, let's see how good a CNN is at learning to classify the MNIST dataset. The detailed logic for a basic implementation in TensorFlow is documented in Listing 3-6. The CNN takes in images of height 28, width 28, and depth 3 corresponding to the RGB channels. The images go through the series of convolution, ReLU activations, and max pooling operations twice before being fed into the fully connected layer and finally to the output layer. The first convolution layer produces 64 feature maps, the second convolution layer provides 128 feature maps, and the fully connected layer has 1024 units. The max pooling layers have been chosen to reduce the feature map size by $\frac{1}{4}$. The feature maps can be considered 2D images.

Listing 3-6.

```
#####
##Import the required libraries and read the MNIST dataset
#####
import tensorflow as tf
import numpy as np
import matplotlib.pyplot as plt
%matplotlib inline
from tensorflow.examples.tutorials.mnist import input_data
import time
mnist = input_data.read_data_sets("MNIST_data/",one_hot=True)

#####
## Set the value of the Parameters
#####

learning_rate = 0.01
epochs = 20
batch_size = 256
num_batches = mnist.train.num_examples/batch_size
input_height = 28
input_width = 28
n_classes = 10
dropout = 0.75
display_step = 1
filter_height = 5
filter_width = 5
depth_in = 1
depth_out1 = 64
depth_out2 = 128
```



```

#####
# input output definition
#####
x = tf.placeholder(tf.float32,[None,28*28])
y = tf.placeholder(tf.float32,[None,n_classes])
keep_prob = tf.placeholder(tf.float32)
#####
## Store the weights
## Number of weights of filters to be learnt in 'wc1' => filter_height*filter_width*depth_in*depth_out1
## Number of weights of filters to be learnt in 'wc2' => filter_height*filter_width*depth_out1*depth_out2
## No of Connections to the fully Connected layer => Each maxpooling operation reduces the image size to 1/4.
## So two maxpooling reduces the imase size to /16. There are depth_out2 number of images each of size 1/16 ## of the original image size of input_height*input_width. So there is total of
## (1/16)*input_height* input_width* depth_out2 pixel outputs which when connected to the fully connected layer ## with 1024 units would provide (1/16)*input_height* input_width* depth_out2*1024 connections.
#####
weights = {
'wc1' : tf.Variable(tf.random_normal([filter_height,filter_width,depth_in,depth_out1])),
'wc2' : tf.Variable(tf.random_normal([filter_height,filter_width,depth_out1,depth_out2])),
'wd1' : tf.Variable(tf.random_normal([(input_height/4)*(input_height/4)* depth_out2,1024])),
'out' : tf.Variable(tf.random_normal([1024,n_classes]))
}
#####
## In the 1st Convolutional Layer there are 64 feature maps and that corresponds to 64 biases in 'bc1'
## In the 2nd Convolutional Layer there are 128 feature maps and that corresponds to 128 biases in 'bc2'
## In the Fully Connected Layer there are 1024units and that corresponds to 1024 biases in 'bd1'
## In the output layet there are 10 classes for the Softmax and that corresponds to 10 biases in 'out'
#####
biases = {
'bc1' : tf.Variable(tf.random_normal([64])),
'bc2' : tf.Variable(tf.random_normal([128])),
'bd1' : tf.Variable(tf.random_normal([1024])),
'out' : tf.Variable(tf.random_normal([n_classes]))
}

```

```
#####
## Create the different layers
#####

'''CONVOLUTION LAYER'''
def conv2d(x,W,b,strides=1):
    x = tf.nn.conv2d(x,W,strides=[1,strides,strides,1],padding='SAME')
    x = tf.nn.bias_add(x,b)
    return tf.nn.relu(x)

'''POOLING LAYER'''
def maxpool2d(x, stride=2):
    return tf.nn.max_pool(x, ksize=[1, stride, stride, 1], strides=[1, stride, stride, 1], padding='
SAME')
#####
## Create the feed forward model
#####
def conv_net(x,weights,biases,dropout):
#####
## Reshape the input in the 4 dimensional image
## 1st dimension - image index
## 2nd dimension - height
## 3rd dimension - width
## 4th dimension - depth
    x = tf.reshape(x,shape=[-1,28,28,1])
#####
## Convolutional layer 1
    conv1 = conv2d(x,weights['wc1'],biases['bc1'])
    conv1 = maxpool2d(conv1,2)
## Convolutional layer 2
    conv2 = conv2d(conv1,weights['wc2'],biases['bc2'])
    conv2 = maxpool2d(conv2,2)
## Now comes the fully connected layer
    fc1 = tf.reshape(conv2,[-1,weights['wd1'].get_shape().as_list()[0]])
    fc1 = tf.add(tf.matmul(fc1,weights['wd1']),biases['bd1'])
    fc1 = tf.nn.relu(fc1)
## Apply Dropout
    fc1 = tf.nn.dropout(fc1,dropout)
## Output class prediction
    out = tf.add(tf.matmul(fc1,weights['out']),biases['out'])
    return out
```

```
#####
# Defining the tensorflow Ops for different activities
#####
pred = conv_net(x,weights,biases,keep_prob)
# Define loss function and optimizer
cost = tf.reduce_mean(tf.nn.softmax_cross_entropy_with_logits(logits=pred,labels=y))
optimizer = tf.train.AdamOptimizer(learning_rate=learning_rate).minimize(cost)
# Evaluate model
correct_pred = tf.equal(tf.argmax(pred,1),tf.argmax(y,1))
accuracy = tf.reduce_mean(tf.cast(correct_pred,tf.float32))
## initializing all variables
init = tf.global_variables_initializer()
#####
## Launch the execution Graph
#####
start_time = time.time()
with tf.Session() as sess:
    sess.run(init)
    for i in range(epochs):
        for j in range(num_batches):

            batch_x,batch_y = mnist.train.next_batch(batch_size)
            sess.run(optimizer, feed_dict={x:batch_x,y:batch_y,keep_prob:dropout})
            loss,acc = sess.run([cost,accuracy],feed_dict={x:batch_x,y:batch_y,keep_prob: 1.})
            if epochs % display_step == 0:
                print("Epoch:", '%04d' % (i+1),
                    "cost=", "{:.9f}".format(loss),
                    "Training accuracy", "{:.5f}".format(acc))
print('Optimization Completed')

y1 = sess.run(pred,feed_dict={x:mnist.test.images[:256],keep_prob: 1})
test_classes = np.argmax(y1,1)
print('Testing Accuracy:',sess.run(accuracy,feed_dict={x:mnist.test.
images[:256],y:mnist.test.labels[:256],keep_prob: 1}))
f, a = plt.subplots(1, 10, figsize=(10, 2))

for i in range(10):
    a[i].imshow(np.reshape(mnist.test.images[i],[28, 28]))
    print test_classes[i]

end_time = time.time()
print('Total processing time:',end_time - start_time)
```

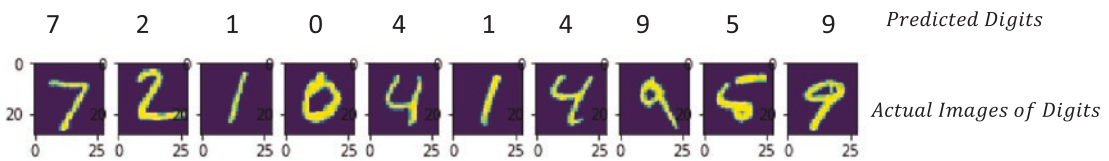

Figure 3-28. Predicted digits versus actual digits from CNN model

With the preceding basic convolutional neural network, which comprises two convolutional-maxpooling-ReLU pairs along with a fully connected layer before the final output SoftMax unit, we can achieve a test-set accuracy of 0.9765625 in just 20 epochs. As we saw previously through the multi-layer Perceptron approach in Chapter 2, with that method we were merely able to get around 91 percent accuracy with 1000 epochs. This is a testimony that for image-recognition problems convolutional neural networks work best.

One more thing I want to emphasize is the importance of tuning the model with the correct set of hyperparameters and prior information. Parameters such as the learning-rate selection can be very tricky since the cost function for neural networks is generally non-convex. A large learning rate can lead to faster convergence to a local minimum but might introduce oscillations, whereas a low learning rate will lead to very slow convergence. Ideally, the learning rate should be low enough that network parameters can converge to a meaningful local minima, and at the same time it should be high enough that the models can reach the minima faster. Generally, for the preceding neural network a learning rate of 0.01 is a little on the higher side, but since we are only training the data on 20 epochs it works well. A lower learning rate wouldn't have achieved such a high accuracy with just 20 epochs. Similarly, the batch size chosen for the mini-batch version of stochastic gradient descent influences the convergence of the training process. A larger batch size might be good since the gradient estimates are less noisy; however, it may come at the cost of increased computation. One also needs to try out different filter sizes as well as experiment with different numbers of feature maps in each convolution layer. The kind of model architecture we choose works as a prior knowledge to the network.

Convolutional Neural Network for Solving Real-World Problems

We will now briefly discuss how to work on real-world image-analytics problems by going through a problem recently hosted in Kaggle by Intel that involved classifying different types of cervical cancer. In this competition, a model needs to be built that identifies a woman's cervix type based on images. Doing so will allow for the effective treatment of patients. Images specific to three types of cancer were provided for the competition. So, the business problem boils down to being a three-class image-classification problem. A basic solution approach to the problem is provided in Listing 3-7.

Listing 3-7.

```
#####
## Load the relevant libraries
#####
from PIL import ImageFilter, ImageStat, Image, ImageDraw
from multiprocessing import Pool, cpu_count
from sklearn.preprocessing import LabelEncoder
import pandas as pd
import numpy as np
import glob
import cv2
import time
from keras.utils import np_utils
import os
import tensorflow as tf
import shuffle

#####
## Read the input images and then resize the image to 64 x 64 x 3 size
#####
def get_im_cv2(path):
    img = cv2.imread(path)
    resized = cv2.resize(img, (64,64), cv2.INTER_LINEAR)
    return resized

#####
## Each of the folders corresponds to a different class
## Load the images into array and then define their output classes based on
## the folder number
#####

def load_train():
    X_train = []
    X_train_id = []
    y_train = []
    start_time = time.time()

    print('Read train images')
    folders = ['Type_1', 'Type_2', 'Type_3']
    for fld in folders:
        index = folders.index(fld)
        print('Load folder {} (Index: {})'.format(fld, index))
        path = os.path.join('.', 'Downloads', 'Intel', 'train', fld, '*.jpg')
        files = glob.glob(path)

        for fl in files:
            flbase = os.path.basename(fl)
            img = get_im_cv2(fl)
            X_train.append(img)
            X_train_id.append(flbase)
            y_train.append(index)
```

```

for fld in folders:
    index = folders.index(fld)
    print('Load folder {} (Index: {})'.format(fld, index))
    path = os.path.join('.', 'Downloads', 'Intel', 'Additional', fld, '*.jpg')
    files = glob.glob(path)

    for fl in files:
        flbase = os.path.basename(fl)
        img = get_im_cv2(fl)
        X_train.append(img)
        X_train_id.append(flbase)
        y_train.append(index)

print('Read train data time: {} seconds'.format(round(time.time() - start_time, 2)))
return X_train, y_train, X_train_id

#####
## Load the test images
#####

def load_test():
    path = os.path.join('.', 'Downloads', 'Intel', 'test', '*.jpg')
    files = sorted(glob.glob(path))

    X_test = []
    X_test_id = []
    for fl in files:
        flbase = os.path.basename(fl)
        img = get_im_cv2(fl)
        X_test.append(img)
        X_test_id.append(flbase)
    path = os.path.join('.', 'Downloads', 'Intel', 'test_stg2', '*.jpg')
    files = sorted(glob.glob(path))
    for fl in files:
        flbase = os.path.basename(fl)
        img = get_im_cv2(fl)
        X_test.append(img)
        X_test_id.append(flbase)

    return X_test, X_test_id

#####
## Normalize the image data to have values between 0 and 1
## by dividing the pixel intensity values by 255.
## Also convert the class label into vectors of length 3 corresponding to
## the 3 classes
## Class 1 - [1 0 0]
## Class 2 - [0 1 0]
## Class 3 - [0 0 1]
#####

```

```

def read_and_normalize_train_data():
    train_data, train_target, train_id = load_train()

    print('Convert to numpy...')
    train_data = np.array(train_data, dtype=np.uint8)
    train_target = np.array(train_target, dtype=np.uint8)

    print('Reshape...')
    train_data = train_data.transpose((0, 2,3, 1))
    train_data = train_data.transpose((0, 1,3, 2))

    print('Convert to float...')
    train_data = train_data.astype('float32')
    train_data = train_data / 255
    train_target = np_utils.to_categorical(train_target, 3)

    print('Train shape:', train_data.shape)
    print(train_data.shape[0], 'train samples')
    return train_data, train_target, train_id

#####
## Normalize test-image data
#####

def read_and_normalize_test_data():
    start_time = time.time()
    test_data, test_id = load_test()

    test_data = np.array(test_data, dtype=np.uint8)
    test_data = test_data.transpose((0,2,3,1))
    train_data = test_data.transpose((0, 1,3, 2))

    test_data = test_data.astype('float32')
    test_data = test_data / 255

    print('Test shape:', test_data.shape)
    print(test_data.shape[0], 'test samples')
    print('Read and process test data time: {} seconds'.format(round(time.time() -
    start_time, 2)))
    return test_data, test_id

#####
## Read and normalize the train data
#####

train_data, train_target, train_id = read_and_normalize_train_data()

#####
## Shuffle the input training data to aid stochastic gradient descent
#####

```

```

list1_shuf = []
list2_shuf = []
index_shuf = range(len(train_data))
shuffle(index_shuf)
for i in index_shuf:
    list1_shuf.append(train_data[i,:,:,:])
    list2_shuf.append(train_target[i,])
list1_shuf = np.array(list1_shuf,dtype=np.uint8)
list2_shuf = np.array(list2_shuf,dtype=np.uint8)

#####
## TensorFlow activities for Network Definition and Training
#####
## Create the different layers

channel_in = 3
channel_out = 64
channel_out1 = 128

'''C O N V O L U T I O N   L A Y E R'''
def conv2d(x,W,b,strides=1):
    x = tf.nn.conv2d(x,W,strides=[1,strides,strides,1],padding='SAME')
    x = tf.nn.bias_add(x,b)
    return tf.nn.relu(x)

''' P O O L I N G   L A Y E R'''
def maxpool2d(x,stride=2):
    return tf.nn.max_pool(x,ksize=[1,stride,stride,1],strides=[1,stride,stride,1],
padding='SAME')

## Create the feed-forward model

def conv_net(x,weights,biases,dropout):

    ## Convolutional layer 1
    conv1 = conv2d(x,weights['wc1'],biases['bc1'])
    conv1 = maxpool2d(conv1,stride=2)
    ## Convolutional layer 2
    conv2a = conv2d(conv1,weights['wc2'],biases['bc2'])
    conv2a = maxpool2d(conv2a,stride=2)
    conv2 = conv2d(conv2a,weights['wc3'],biases['bc3'])
    conv2 = maxpool2d(conv2,stride=2)

    ## Now comes the fully connected layer

    fc1 = tf.reshape(conv2,[-1,weights['wd1'].get_shape().as_list()[0]])
    fc1 = tf.add(tf.matmul(fc1,weights['wd1']),biases['bd1'])
    fc1 = tf.nn.relu(fc1)

    ## Apply Dropout
    fc1 = tf.nn.dropout(fc1,dropout)

```



```

## Another fully Connected Layer
fc2 = tf.add(tf.matmul(fc1,weights['wd2']),biases['bd2'])
fc2 = tf.nn.relu(fc2)
## Apply Dropout
fc2 = tf.nn.dropout(fc2,dropout)

## Output class prediction

out = tf.add(tf.matmul(fc2,weights['out']),biases['out'])
return out

#####
## Define several parameters for the network and learning
#####
start_time = time.time()
learning_rate = 0.01
epochs = 200
batch_size = 128
num_batches = list1_shuf.shape[0]/128
input_height = 64
input_width = 64
n_classes = 3
dropout = 0.5
display_step = 1
filter_height = 3
filter_width = 3
depth_in = 3
depth_out1 = 64
depth_out2 = 128
depth_out3 = 256

#####
# input-output definition
#####

x = tf.placeholder(tf.float32,[None,input_height,input_width,depth_in])
y = tf.placeholder(tf.float32,[None,n_classes])
keep_prob = tf.placeholder(tf.float32)

#####
## Define the weights and biases
#####

weights = {
    'wc1' : tf.Variable(tf.random_normal([filter_height,filter_width,depth_in,depth_out1])),
    'wc2' : tf.Variable(tf.random_normal([filter_height,filter_width,depth_out1,depth_out2])),
    'wc3' : tf.Variable(tf.random_normal([filter_height,filter_width,depth_out2,depth_out3])),
    'wd1' : tf.Variable(tf.random_normal([(input_height/8)*(input_height/8)*256,512])),
    'wd2' : tf.Variable(tf.random_normal([512,512])),
    'out' : tf.Variable(tf.random_normal([512,n_classes]))
}

```

```

biases = {
    'bc1' : tf.Variable(tf.random_normal([64])),
    'bc2' : tf.Variable(tf.random_normal([128])),
    'bc3' : tf.Variable(tf.random_normal([256])),
    'bd1' : tf.Variable(tf.random_normal([512])),
    'bd2' : tf.Variable(tf.random_normal([512])),
    'out' : tf.Variable(tf.random_normal([n_classes]))
}

#####
## Define the TensorFlow ops for training
#####

pred = conv_net(x,weights,biases,keep_prob)

# Define loss function and optimizer
cost = tf.reduce_mean(tf.nn.softmax_cross_entropy_with_logits(logits=pred,labels=y))
optimizer = tf.train.AdamOptimizer(learning_rate=learning_rate).minimize(cost)

# Evaluate model

correct_pred = tf.equal(tf.argmax(pred,1),tf.argmax(y,1))
accuracy = tf.reduce_mean(tf.cast(correct_pred,tf.float32))

## Define the initialization op

init = tf.global_variables_initializer()
#####
## Launch the execution graph and invoke the training
#####
start_time = time.time()
with tf.Session() as sess:
    sess.run(init)

    for i in range(epochs):

        for j in range(num_batches):

            batch_x,batch_y = list1_shuf[i*(batch_size):(i+1)*(batch_size)],
                list2_shuf[i*(batch_size):(i+1)*(batch_size)]
            sess.run(optimizer, feed_dict={x:batch_x,y:batch_y,keep_prob:dropout})
            loss,acc = sess.run([cost,accuracy],feed_dict={x:batch_x,y:batch_y,keep_prob: 1.})

        if epochs % display_step == 0:
            print("Epoch:", '%04d' % (i+1),
                  "cost=", "{:.9f}".format(loss),
                  "Training accuracy", "{:.5f}".format(acc))

    print('Optimization Completed')

```

```

end_time = time.time()
print('Total processing time:',end_time - start_time)

-- output --

('Epoch:', '0045', 'cost=', '0.994687378', 'Training accuracy', '0.53125')
('Epoch:', '0046', 'cost=', '1.003623009', 'Training accuracy', '0.52344')
('Epoch:', '0047', 'cost=', '0.960040927', 'Training accuracy', '0.56250')
('Epoch:', '0048', 'cost=', '0.998520255', 'Training accuracy', '0.54688')
('Epoch:', '0049', 'cost=', '1.016047001', 'Training accuracy', '0.50781')
('Epoch:', '0050', 'cost=', '1.043521643', 'Training accuracy', '0.49219')
('Epoch:', '0051', 'cost=', '0.959320068', 'Training accuracy', '0.58594')
('Epoch:', '0052', 'cost=', '0.935006618', 'Training accuracy', '0.57031')
('Epoch:', '0053', 'cost=', '1.031400681', 'Training accuracy', '0.49219')
('Epoch:', '0054', 'cost=', '1.023633003', 'Training accuracy', '0.50781')
('Epoch:', '0055', 'cost=', '1.007938623', 'Training accuracy', '0.53906')
('Epoch:', '0056', 'cost=', '1.033236384', 'Training accuracy', '0.46094')
('Epoch:', '0057', 'cost=', '0.939492166', 'Training accuracy', '0.60938')
('Epoch:', '0058', 'cost=', '0.986051500', 'Training accuracy', '0.56250')
('Epoch:', '0059', 'cost=', '1.019751549', 'Training accuracy', '0.51562')
('Epoch:', '0060', 'cost=', '0.955037951', 'Training accuracy', '0.57031')
('Epoch:', '0061', 'cost=', '0.963475347', 'Training accuracy', '0.58594')
('Epoch:', '0062', 'cost=', '1.019685864', 'Training accuracy', '0.50000')
('Epoch:', '0063', 'cost=', '0.970604420', 'Training accuracy', '0.53125')
('Epoch:', '0064', 'cost=', '0.962844968', 'Training accuracy', '0.54688')

```

This model achieves a log-loss of around 0.97 in the competition leaderboard, whereas the best model for this competition achieved around 0.78 log-loss. This is because the model is a basic implementation that doesn't take care of other advanced concepts in image processing. We will study one such advanced technique called transfer learning later in the book that works well when the number of images provided is less. A few points about the implementation that might be of interest to the reader are as follows:

- The images have been read as a three-dimensional Numpy array and resized through OpenCV and then appended to a list. The list is then converted to Numpy array, and hence we get a four-dimensional Numpy array or Tensor for both the training and testing datasets. The training and testing image Tensors have been transposed to have the dimensions aligned in order of image number, location along height of image, location along width of image, and image channels.
- The images have been normalized to have values between 0 and 1 by dividing by the maximum value of pixel intensity; i.e., 255. This aids the gradient-based optimization.
- The images have been shuffled randomly so that the mini batches have images of the three classes randomly arranged.
- The rest of the network implementation is like the MNIST classification problem but with three layers of the convolution-ReLU-max pooling combination and two layers of fully connected layers before the final SoftMax output layer.
- The code involving prediction and submission has been left out here.

Batch Normalization

Batch normalization was invented by Sergey Ioffe and Christian Szegedy and is one of the pioneering elements in the deep-learning space. The original paper for batch normalization is titled “Batch Normalization: Accelerating Deep Network Training by Reducing Internal Covariate Shift” and can be located at <https://arxiv.org/abs/1502.03167>.

When training a neural network through stochastic gradient descent, the distribution of the inputs to each layer changes due to the update of weights on the preceding layers. This slows down the training process and makes it difficult to train very deep neural networks. The training process for neural networks is complicated by the fact that the input to any layer is dependent on the parameters for all preceding layers, and thus even small parameter changes can have an amplified effect as the network grows. This leads to input-distribution changes in a layer.

Now, let’s try to understand what might go wrong when the input distribution to the activation functions in a layer change because of weight changes in the preceding layer.

A sigmoid or tanh activation function has good linear gradients only within a specified range of its input, and the gradient drops to zero once the inputs grow large.

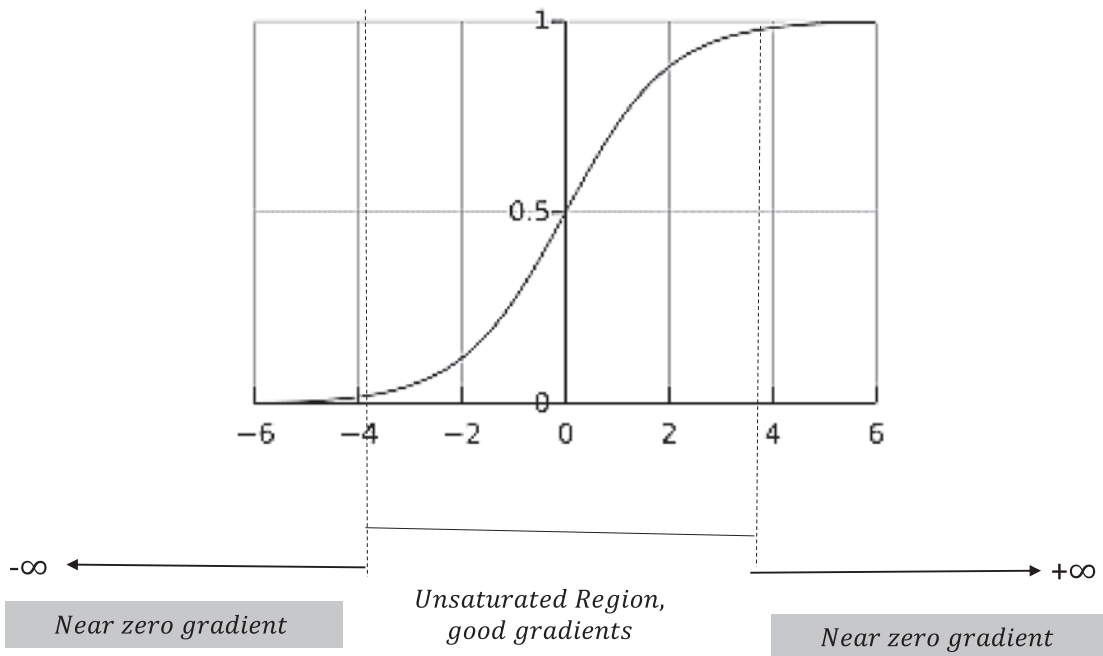

Figure 3-29. Sigmoid function with its small unsaturated region

The parameter change in the preceding layers might change the input probability distribution to a sigmoid units layer in such a way that most of the inputs to the sigmoids belong to the saturation zone and hence produce near-zero gradients, as shown in Figure 3-29. Because of these zero or near-zero gradients, the learning becomes terribly slow or stops entirely. One way to avoid this problem is to have rectified linear units (ReLUs). The other way to avoid this problem is to keep the distribution of inputs to the sigmoid units stable within the unsaturated zone so that stochastic gradient descent doesn’t get stuck in a saturated zone.

This phenomenon of change in the distribution of the input to the internal network units has been referred to by the inventors of the batch normalization process as *internal covariate shift*.

Batch normalization reduces the internal covariate shift by normalizing the inputs to a layer to have a zero mean and unit standard deviation. While training, the mean and standard deviation are estimated from the mini-batch samples at each layer, whereas at test-prediction time generally the population variance and mean are used.

If a layer receives a vector $x = [x_1 x_2 \dots x_n]^T \in \mathbb{R}^{n \times 1}$ of input activations from the preceding layers, then at each mini batch consisting of m data points the input activations are normalized as follows:

$$\hat{x}_i = \frac{x_i - E[x_i]}{\sqrt{\text{Var}[x_i] + \epsilon}}$$

where

$$u_B = \frac{1}{m} \sum_{k=1}^m x_i^{(k)}$$

$$\sigma_B^2 = \frac{1}{m} \sum_{k=1}^m (x_i^{(k)} - E[x_i])^2$$

Statistically, u_B and σ_B^2 are nothing but the sample mean and biased sample standard variance.

Once the normalization is done, \hat{x}_i is not fed to the activation function directly but rather is scaled and shifted by introducing parameters γ and β before feeding it to the activation functions. If we restrict the input activations to the normalized values, they may change what the layer can represent. So, the idea is to apply a linear transformation on the normalized value through the following transformation so that if the network, through training, feels that the original values before any transformation are good for the network it can recover the original values. The actual transformed input activation y_i fed to the activation function is given by

$$y_i = \gamma \hat{x}_i + \beta$$

The parameters u_B , σ_B^2 , γ , and β are to be learned by backpropagation much like the other parameters. As stated earlier, the model might learn $\gamma = \text{Var}[x_i]$ and $\beta = E[x_i]$ if it feels the original values from the network are more desirable.

A very natural question that may come up is why we are taking the mini-batch mean u_B and variance σ_B^2 as parameters to be learned through batch propagation and not estimating them as running averages over mini batches for normalization purposes. This doesn't work, since the u_B and σ_B^2 are dependent on other parameters of the model through x_p , and when we directly estimate these as running averages this dependency is not accounted for in the optimization process. To keep those dependencies intact, u_B and σ_B^2 should participate in the optimization process as parameters since the gradients of the u_B and σ_B^2 with respect to the other parameters on which x_i depends are critical to the learning process. The overall effect of this optimization modifies the model in such a way that the input \hat{x}_i keeps zero mean and unit standard deviation.

During inference or testing time the population statistics $E[x_i]$ and $\text{Var}[x_i]$ are used for normalization by keeping a running average of the mini-batch statistics.

$$E[x_i] = E[u_B]$$

$$\text{Var}[x_i] = \left(\frac{m}{m-1} \right) E[\sigma_B^2]$$

This correction factor is required to get an unbiased estimate of the Population variance. Mentioned here are a couple of the advantages of batch normalization:

- Models can be trained faster because of the removal or reduction of internal covariate shift. A smaller number of training iterations would be required to achieve good model parameters.
- Batch normalization has some regularizing power and at times eliminates the need for dropout.
- Batch normalization works well with convolutional neural networks wherein there is one set of γ and β for each output feature map.

Different Architectures in Convolutional Neural Networks

In this section, we will go through a few widely used convolutional neural network architectures used today. These network architectures are not only used for classification, but also, with minor modification, are used in segmentation, localization, and detection. Also, there are pre-trained versions of each of these networks that enable the community to do transfer learning or fine-tune the models. Except LeNet, almost all the CNN models have won the ImageNet competition for classification of a thousand classes.

LeNet

The first successful convolutional neural network was developed by Yann LeCun in 1990 for classifying handwritten digits successfully for OCR-based activities such as reading ZIP codes, checks, and so on. LeNet5 is the latest offering from Yann LeCun and his colleagues. It takes in 32×32 -size images as input and passes them through a convolutional layer to produce six feature maps of size 28×28 . The six feature maps are then sub-sampled to produce six output images of size 14×14 . Sub-sampling can be thought of as a pooling operation. The second convolutional layer has 16 feature maps of size 10×10 while the second sub-sampling layer reduces the feature map sizes to 5×5 . This is followed by two fully connected layers of 120 and 84 units respectively, followed by the output layer of ten classes corresponding to ten digits. Figure 3-30 represents the LeNet5 architectural diagrams.

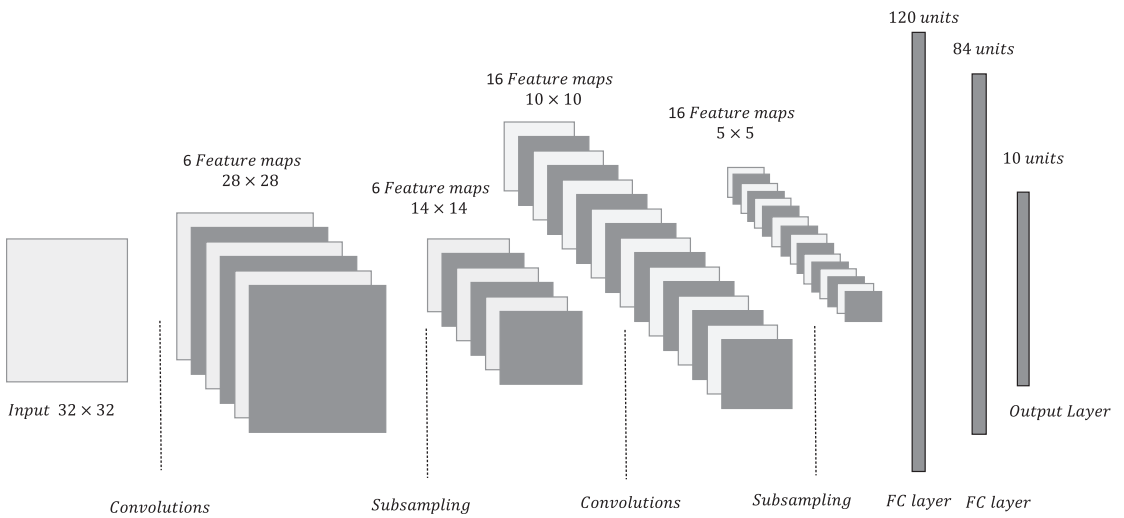

Figure 3-30. LeNet5 architectural diagram

Key features of the LeNet5 network are as follows:

- The pooling through sub-sampling takes 2×2 neighborhood patches and sums up the four-pixel intensity values. The sum is scaled by a trainable weight and a bias and then fed through a sigmoid activation function. This is a little different from what is done for max pooling and average pooling.
- The filter kernel used for convolution is of size 5×5 . The output units are radial basis function (RBF) units instead of the SoftMax functions that we generally use. The 84 units of the fully connected layers had 84 connections to each of the classes and hence 84 corresponding weights. The 84 weights/class represent each class's characteristics. If the inputs to those 84 units are very close to the weights corresponding to a class, then the inputs are more likely to belong to that class. In a SoftMax we look at the dot product of the inputs to each of the class's weight vectors, while in RBF units we look at the Euclidean distance between the input and the output class representative's weight vectors. The greater the Euclidean distance, the smaller the chance is of the input belonging to that class. The same can be converted to probability by exponentiating the negative of the distance and then normalizing over the different classes. The Euclidean distances over all the classes for an input record would act as the loss function for that input. Let $x = [x_1 x_2 \dots x_{84}]^T \in \mathbb{R}^{84 \times 1}$ be the output vector of the fully connected layer. For each class, there would be 84 weight connections. If the representative class's weight vector for the i th class is $w_i \in \mathbb{R}^{84 \times 1}$ then the output of the i th class unit can be given by the following:

$$\|x - w_i\|_2^2 = \sum_{j=1}^{84} (x_j - w_{ij})^2$$

- The representative weights for each class are fixed beforehand and are not learned weights.

AlexNet

The AlexNet CNN architecture was developed by Alex Krizhevsky, Ilya Sutskever, and Geoffrey Hinton in 2012 to win the 2012 ImageNet ILSVRC (ImageNet Large-Scale Visual Recognition Challenge). The original paper pertaining to AlexNet is titled “ImageNet Classification with Deep Convolutional Neural Networks” and can be located at <https://papers.nips.cc/paper/4824-imagenet-classification-with-deep-convolutional-neural-networks.pdf>.

It was the first time that a CNN architecture beat other methods by a huge margin. Their network achieved an error rate of 15.4 percent on its top five predictions as compared to the 26.2 percent error rate for the second-best entry. The architectural diagram of AlexNet is represented in Figure 3-31.

AlexNet consists of five convolutional layers, max pooling layers, and dropout layers, and three fully connected layers in addition to the input and output layer of a thousand class units. The inputs to the network are images of size $224 \times 224 \times 3$. The first convolutional layer produces 96 feature maps corresponding to 96 filter kernels of size $11 \times 11 \times 3$ with strides of four pixel units. The second convolutional layer produces 256 feature maps corresponding to filter kernels of size $5 \times 5 \times 48$. The first two convolutional layers are followed by max pooling layers, whereas the next three convolutional layers are placed one after another without any intermediate max pooling layers. The fifth convolutional layer is followed by a max pooling layer, two fully connected layers of 4096 units, and finally a SoftMax output layer of one thousand classes. The third convolutional layer has 384 filter kernels of size $3 \times 3 \times 256$, whereas the fourth and fifth convolutional layers have 384 and 256 filter kernels each of size $3 \times 3 \times 192$. A dropout of 0.5 was used in the last two fully connected layers. You will notice that the depth of the filter kernels for convolutions is half the number of feature maps in the preceding layer for all but the third convolutional layer. This is because AlexNet was at that time computationally expensive and hence the training had to be split between two separate GPUs. However, if you observe carefully, for the third convolutional activity there is cross-connectivity for convolution and so the filter kernel is of dimension $3 \times 3 \times 256$ and not $3 \times 3 \times 128$. The same kind of cross-connectivity applies to the fully connected layers, and hence they behave as ordinary fully connected layers with 4096 units.

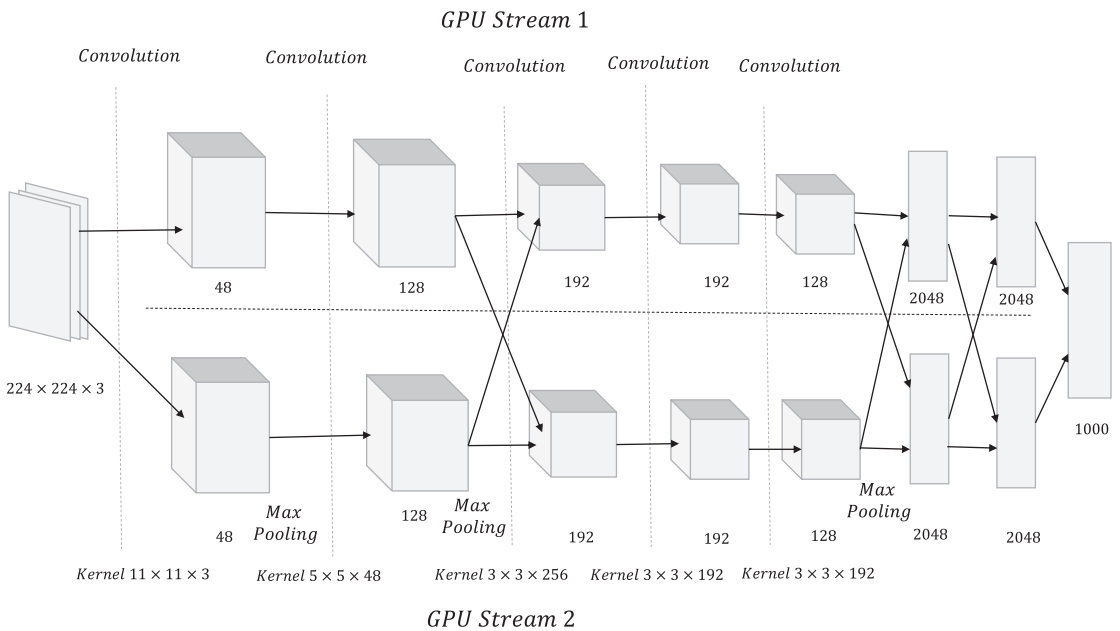

Figure 3-31. AlexNet architecture

The key features of AlexNet are as follows:

- ReLU activation functions were used for non-linearity. They had a huge impact since RELUs are significantly easier to compute and have constant non-saturating gradients as opposed to sigmoid and tanh activation functions, whose gradients tend to zero for very high and low values of input.
- Dropout was used to reduce overfitting in the model.
- Overlapping pooling was used as opposed to non-overlapping pooling.
- The model was trained on two GPU GTX 580 for around five days for fast computation.
- The dataset size was increased through data-augmentation techniques, such as image translations, horizontal reflections, and patch extractions.

VGG16

The VGG group in 2014 were runners up in the ILSVRC-2014 competition with a 16-layer architecture named VGG16. It uses a deep yet simple architecture that has gained a lot of popularity since. The paper pertaining to the VGG network is titled “Very Deep Convolutional Networks for Large-Scale Image Recognition” and is authored by [Karen Simonyan](#) and [Andrew Zisserman](#). The paper can be located at <https://arxiv.org/abs/1409.1556>.

Instead of using a large kernel-filter size for convolution, VGG16 architecture used 3×3 filters and followed it up with ReLU activations and max pooling with a 2×2 receptive field. The inventors' reasoning was that using two 3×3 convolution layers is equivalent to having one 5×5 convolution while retaining the advantages of a smaller kernel-filter size; i.e., realizing a reduction in the number of parameters and realizing more non-linearity because of two convolution–ReLU pairs as opposed to one. A special property of this network is that as the spatial dimensions of the input volume reduces because of convolution and max pooling, the number of feature maps increases due to the increase in the number of filters as we go deep into the network.

All Convolutions with stride 1 and pad 1
Max Pooling with stride 2

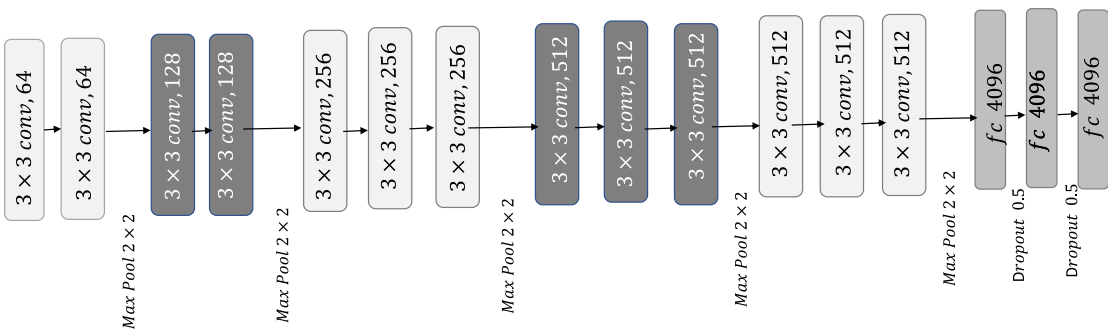

Figure 3-32. VGG16 architecture

Figure 3-32 represents the architecture of VGG16. The input to the network are images of size $224 \times 224 \times 3$. The first two convolutional layers produce 64 feature maps, each followed by max pooling. The filters for convolution are of spatial size 3×3 with a stride of 1 and pad of 1. Max pooling is of size 2×2 with stride of 2 for the whole network. The third and fourth convolutional layers produce 128 feature maps, each followed by a max pooling layer. The rest of the network follows in a similar fashion, as shown in the Figure 3-32. At the end of the network there are three fully connected layers of 4096 units, each followed by the output SoftMax layer of a thousand classes. Dropout is set at 0.5 for the fully connected layers. All the units in the network have ReLU activations.

ResNet

ResNet is a 152-layer-deep convolutional neural network from Microsoft that won the ILSVRC 2015 competition with an error rate of only 3.6 percent, which is perceived to be better than the human error rate of 5–10 percent. The paper on ResNet, authored by [Kaiming He](#), [Xiangyu Zhang](#), [Shaoqing Ren](#), and [Jian Sun](#), is titled “Deep Residual Learning for Image Recognition” and can be located at <https://arxiv.org/abs/1512.03385>. Apart from being deep, ResNet implements a unique idea of residual block. After each series of convolution–ReLU–convolution operations, the input to the operation is fed back to the output of the operation. In traditional methods while doing Convolution and other transformations, we try to fit an underlying mapping to the original data to solve the classification task. However, with ResNet’s residual block concept, we try to learn a residual mapping and not a direct mapping from the input to output. Formally, in each small block of activities we add the input to the block to the output. This is illustrated in Figure 3-33. This concept is based on the hypothesis that it is easier to fit a residual mapping than to fit the original mapping from input to output.

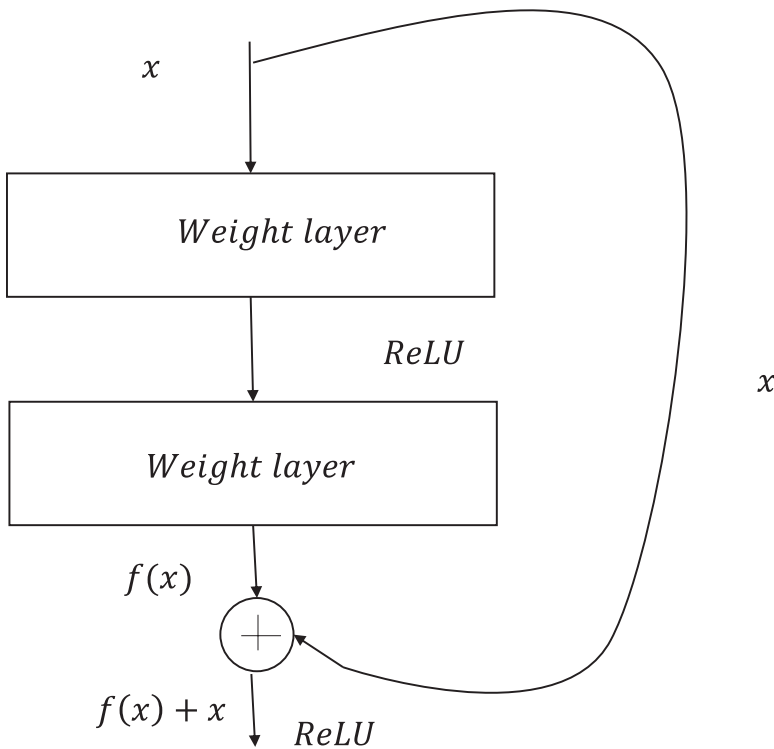

Figure 3-33. Residual block

Transfer Learning

Transfer learning in a broad sense refers to storing knowledge gained while solving a problem and using that knowledge for a different problem in a similar domain. Transfer learning has been hugely successful in the field of deep learning for a variety of reasons.

Deep-learning models in general have a huge number of parameters because of the nature of the hidden layers and the connectivity scheme within the different units. To train such a huge model, lots of data is required or the model will suffer from overfitting problems. In many problems, the huge amount of data required to train the model is not available but the nature of the problem requires a deep-learning solution in order to have a reasonable impact. For instance, in image processing for object recognition, deep-learning models are known to provide state-of-the-art solutions. In such cases, transfer learning can be used to generate generic features from a pre-trained deep-learning model and then use those features to build a simple model to solve the problem. So, the only parameters for this problem are the ones used to build the simple model. The pre-trained models are generally trained on a huge corpus of data and thus have reliable parameters.

When we process images through several layers of convolutions, the initial layers learn to detect very generic features such as curls and edges. As the network grows deeper, the convolutional layers in the deeper layers learn to detect more complex features relevant to the specific kind of dataset. For example, in a classification the deeper layers would learn to detect features such as eyes, nose, face, and so forth.

Let's assume we have a VGG16 architecture model trained on one thousand categories of the ImageNet dataset. Now, if we get a smaller dataset that has fewer categories of images similar to those of the VGG16 pre-trained model dataset, then we can use the same VGG16 model up to the fully connected layer and then replace the output layer with the new classes. Also, we keep the weights of the network fixed till the fully

connected layer and only train the model to learn the weights from the fully connected layer to the output layer. This is because the dataset's nature is the same as the smaller dataset's, and thus the features learned in the pre-trained model through the different parameters are good enough for the new classification problem, and we only need to learn the weights from the fully connected layer to the output layer. This is a huge reduction in the number of parameters to learn, and it will reduce the overfitting. Had we trained the small dataset using VGG16 architecture, it might have suffered from severe overfitting because of the large number of parameters to learn on a small dataset.

What do you do when the dataset's nature is very different from that of the dataset used for the pre-trained model?

Well, in that case, we can use the same pre-trained model but fix only the parameters for the first couple of sets of convolution-ReLUs-max pooling layers and then add a couple of convolution-ReLU-max pooling layers that would learn to detect features intrinsic to the new dataset. Finally, we would have to have a fully connected layer followed by the output layer. Since we are using the weights of the initial sets of convolution-ReLUs-max pooling layers from the pre-trained VGG16 network, the parameters with respect to those layers need not be learned. As mentioned earlier, the early layers of convolution learn very generic features, such as edges and curves, that are applicable to all kinds of images. The rest of the network would need to be trained to learn specific features inherent to the specific problem dataset.

Guidelines for Using Transfer Learning

The following are a few guidelines as to when and how to use a pre-trained model for transfer learning:

- The size of the problem dataset is large, and the dataset is similar to the one used for the pre-trained model—this is the ideal scenario. We can retain the whole model architecture as it is except maybe the output layer when it has a different number of classes than the pre-trained one. We can then train the model using the weights of the pre-trained model as initial weights for the model.
- The size of the problem dataset is large, but the dataset is dissimilar to the one used for the pre-trained model—in this case, since the dataset is large, we can train the model from scratch. The pre-trained model will not give any gains here since the dataset's nature is very dissimilar, and since we have a large dataset we can afford to train the whole network from scratch without overfitting related to large networks trained on small datasets.
- The size of the problem dataset is small, and the dataset is similar to the one used for the pre-trained model—this is the case that we discussed earlier. Since the dataset content is similar, we can reuse the existing weights of most of the model and only change the output layer based on the classes in the problem dataset. Then, we train the model only for the weights in the last layer. For example, if we get images like ImageNet for only dogs and cats we can pick up a VGG16 model pre-trained on ImageNet and just modify the output layer to have two classes instead of a thousand. For the new network model, we just need to train the weights specific to the final output layer, keeping all the other weights the same as those of the pre-trained VGG16 model.
- The size of the problem dataset is small and the dataset is dissimilar to the one used in the pre-trained model—this is not such a good situation to be in. As discussed earlier, we can freeze the weights of a few initial layers of a pre-trained network and then train the rest of the model on the problem dataset. The output layer, as usual, needs to be changed as per the number of classes in the problem dataset. Since we don't have a large dataset, we are trying to reduce the number of parameters as much as possible by reusing weights of the initial layers of the pre-trained model. Since the first few layers of CNN learn generic features inherent to any kind of image, this is possible.

Transfer Learning with Google’s InceptionV3

InceptionV3 is one of the state-of-the-art convolutional neural networks from Google. It’s an advanced version of GoogLeNet that won the ImageNet ILSVRC-2014 competition with its out-of-the-box convolutional neural network architecture. The details of the network are documented in the paper titled “Rethinking the Inception Architecture for Computer Vision” by [Christian Szegedy](#) and his collaborators. The paper can be located at <https://arxiv.org/abs/1512.00567>. The core element of GoogLeNet and its modified versions is the introduction of an inception module to do the convolution and pooling. In traditional convolutional neural networks, after a convolution layer we either perform another convolution or max pooling, whereas in the inception module a series of convolutions and max pooling is done in parallel at each layer, and later the feature maps are merged. Also, in each layer convolution is not done with one kernel-filter size but rather with multiple kernel-filter sizes. An inception module is presented in Figure 3-34 below. As we can see, there is a series of convolutions in parallel along with max pooling, and finally all the output feature maps merge in the filter concatenation block. 1×1 convolutions do a dimensionality reduction and perform an operation like average pooling. For example, let’s say we have an input volume of $224 \times 224 \times 160$, with 160 being the number of feature maps. A convolution with a $1 \times 1 \times 20$ filter kernel will create an output volume of $224 \times 224 \times 20$.

This kind of network works well since the different kernel sizes extract feature information at different granular levels based on the size of the filter’s receptive field. Receptive fields of 3×3 will extract much more granular information than will a 5×5 receptive field.

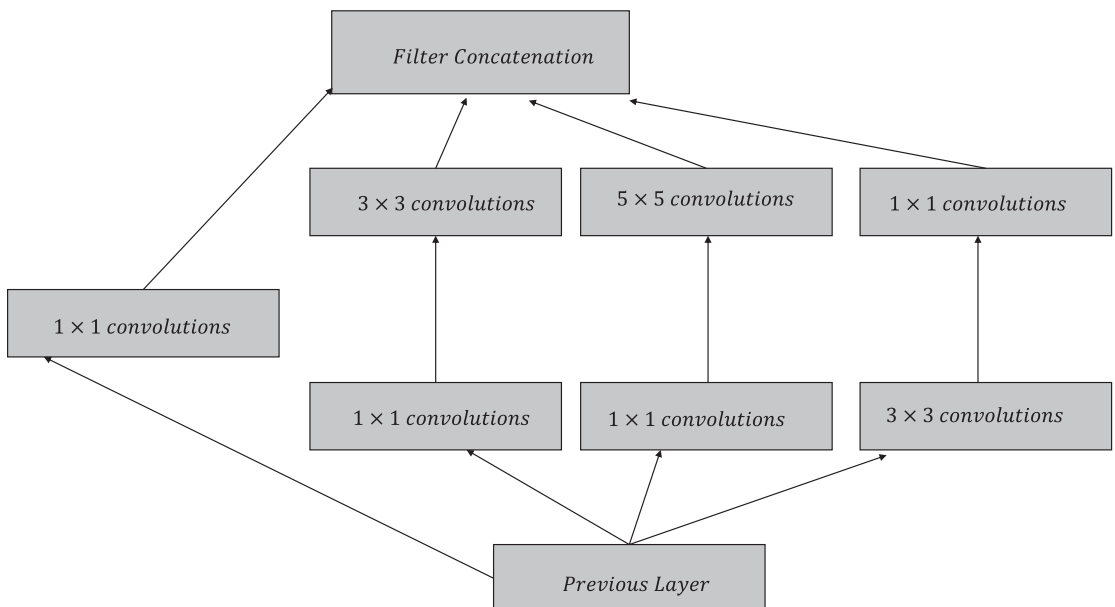

Figure 3-34. Inception module

Google’s TensorFlow provides a pre-trained model that is trained on the ImageNet data. It can be used for transfer learning. We use the pre-trained model from Google and retrain it on a set of cat versus dog images extracted from <https://www.kaggle.com/c/dogs-vs-cats/data>. The `train.zip` dataset contains 25,000 images, with 12,500 images each for cats and dogs.

The pre-trained model can be found in the TensorFlow GitHub Examples folder. Listing 3-8 shows the steps one needs to follow in order to execute and use the model for transfer-learning purposes. Clone the TensorFlow GitHub repository, since the model sits within it in the Examples folder. Once done, we are all set to enter the cloned TensorFlow folder and execute the commands in Listing 3-8.

Listing 3-8.

#Step1 - Download the following dataset and un-tar it since it would be used for building the retrainer for transfer learning

```
cd - curl -O http://download.tensorflow.org/example_images/flower_photos.tgz
```

```
tar xzf flower_photos.tgz
```

Step2 - Enter the cloned tensorflow folder and build the image retrainer by executing the following command

```
bazel build tensorflow/examples/image_retraining:retrain
```

Step3 - Once the model is built with the preceding command we are all set to retrain the model based on our input.

In this case we will test with the Cat vs Dog dataset extracted from Kaggle. The dataset has two classes. For using the dataset on this model the images pertaining to the classes have to be kept in different folders. The Cat and Dog sub-folders were created within an animals folder. Next we retrain the model using the pre-trained InceptionV3 model. All the layers and weights of the pre-trained model would be transferred to the re-trained model. Only the output layer would be modified to have two classes instead of the 1000 on which the pre-trained model is built. In the re-training only the weights from the last fully connected layer to the new output layer of two classes would be learned in the retraining. The following command does the retraining:

```
bazel-bin/tensorflow/examples/image_retraining/retrain --image_dir ~/Downloads/animals
```

```
-- Output Log from Model retraining in the Final Few Steps of Learning --
2017-07-05 09:28:26.133994: Step 3750: Cross entropy = 0.006824
2017-07-05 09:28:26.173795: Step 3750: Validation accuracy = 100.0% (N=100)
2017-07-05 09:28:26.616457: Step 3760: Train accuracy = 99.0%
2017-07-05 09:28:26.616500: Step 3760: Cross entropy = 0.017717
2017-07-05 09:28:26.656621: Step 3760: Validation accuracy = 100.0% (N=100)
2017-07-05 09:28:27.055419: Step 3770: Train accuracy = 100.0%
2017-07-05 09:28:27.055461: Step 3770: Cross entropy = 0.004180
2017-07-05 09:28:27.094449: Step 3770: Validation accuracy = 99.0% (N=100)
2017-07-05 09:28:27.495100: Step 3780: Train accuracy = 100.0%
2017-07-05 09:28:27.495154: Step 3780: Cross entropy = 0.014055
2017-07-05 09:28:27.540385: Step 3780: Validation accuracy = 99.0% (N=100)
2017-07-05 09:28:27.953271: Step 3790: Train accuracy = 99.0%
2017-07-05 09:28:27.953315: Step 3790: Cross entropy = 0.029298
```

2017-07-05 09:28:27.992974: Step 3790: Validation accuracy = 100.0% (N=100)
2017-07-05 09:28:28.393039: Step 3800: Train accuracy = 98.0%
2017-07-05 09:28:28.393083: Step 3800: Cross entropy = 0.039568
2017-07-05 09:28:28.432261: Step 3800: Validation accuracy = 99.0% (N=100)
2017-07-05 09:28:28.830621: Step 3810: Train accuracy = 98.0%
2017-07-05 09:28:28.830664: Step 3810: Cross entropy = 0.032378
2017-07-05 09:28:28.870126: Step 3810: Validation accuracy = 100.0% (N=100)
2017-07-05 09:28:29.265780: Step 3820: Train accuracy = 100.0%
2017-07-05 09:28:29.265823: Step 3820: Cross entropy = 0.004463
2017-07-05 09:28:29.304641: Step 3820: Validation accuracy = 98.0% (N=100)
2017-07-05 09:28:29.700730: Step 3830: Train accuracy = 100.0%
2017-07-05 09:28:29.700774: Step 3830: Cross entropy = 0.010076
2017-07-05 09:28:29.741322: Step 3830: Validation accuracy = 100.0% (N=100)
2017-07-05 09:28:30.139802: Step 3840: Train accuracy = 99.0%
2017-07-05 09:28:30.139847: Step 3840: Cross entropy = 0.034331
2017-07-05 09:28:30.179052: Step 3840: Validation accuracy = 100.0% (N=100)
2017-07-05 09:28:30.575682: Step 3850: Train accuracy = 97.0%
2017-07-05 09:28:30.575727: Step 3850: Cross entropy = 0.032292
2017-07-05 09:28:30.615107: Step 3850: Validation accuracy = 100.0% (N=100)
2017-07-05 09:28:31.036590: Step 3860: Train accuracy = 100.0%
2017-07-05 09:28:31.036635: Step 3860: Cross entropy = 0.005654
2017-07-05 09:28:31.076715: Step 3860: Validation accuracy = 99.0% (N=100)
2017-07-05 09:28:31.489839: Step 3870: Train accuracy = 99.0%
2017-07-05 09:28:31.489885: Step 3870: Cross entropy = 0.047375
2017-07-05 09:28:31.531109: Step 3870: Validation accuracy = 99.0% (N=100)
2017-07-05 09:28:31.931939: Step 3880: Train accuracy = 99.0%
2017-07-05 09:28:31.931983: Step 3880: Cross entropy = 0.021294
2017-07-05 09:28:31.972032: Step 3880: Validation accuracy = 98.0% (N=100)
2017-07-05 09:28:32.375811: Step 3890: Train accuracy = 100.0%
2017-07-05 09:28:32.375855: Step 3890: Cross entropy = 0.007524
2017-07-05 09:28:32.415831: Step 3890: Validation accuracy = 99.0% (N=100)
2017-07-05 09:28:32.815560: Step 3900: Train accuracy = 100.0%
2017-07-05 09:28:32.815604: Step 3900: Cross entropy = 0.005150
2017-07-05 09:28:32.855788: Step 3900: Validation accuracy = 99.0% (N=100)
2017-07-05 09:28:33.276503: Step 3910: Train accuracy = 99.0%
2017-07-05 09:28:33.276547: Step 3910: Cross entropy = 0.033086
2017-07-05 09:28:33.316980: Step 3910: Validation accuracy = 98.0% (N=100)
2017-07-05 09:28:33.711042: Step 3920: Train accuracy = 100.0%
2017-07-05 09:28:33.711085: Step 3920: Cross entropy = 0.004519
2017-07-05 09:28:33.750476: Step 3920: Validation accuracy = 99.0% (N=100)
2017-07-05 09:28:34.147856: Step 3930: Train accuracy = 100.0%
2017-07-05 09:28:34.147901: Step 3930: Cross entropy = 0.005670
2017-07-05 09:28:34.191036: Step 3930: Validation accuracy = 99.0% (N=100)
2017-07-05 09:28:34.592015: Step 3940: Train accuracy = 99.0%
2017-07-05 09:28:34.592059: Step 3940: Cross entropy = 0.019866
2017-07-05 09:28:34.632025: Step 3940: Validation accuracy = 98.0% (N=100)
2017-07-05 09:28:35.054357: Step 3950: Train accuracy = 100.0%
2017-07-05 09:28:35.054409: Step 3950: Cross entropy = 0.004421
2017-07-05 09:28:35.100622: Step 3950: Validation accuracy = 96.0% (N=100)
2017-07-05 09:28:35.504866: Step 3960: Train accuracy = 100.0%
2017-07-05 09:28:35.504910: Step 3960: Cross entropy = 0.009696
2017-07-05 09:28:35.544595: Step 3960: Validation accuracy = 99.0% (N=100)

```

2017-07-05 09:28:35.940758: Step 3970: Train accuracy = 99.0%
2017-07-05 09:28:35.940802: Step 3970: Cross entropy = 0.013898
2017-07-05 09:28:35.982500: Step 3970: Validation accuracy = 100.0% (N=100)
2017-07-05 09:28:36.381933: Step 3980: Train accuracy = 99.0%
2017-07-05 09:28:36.381975: Step 3980: Cross entropy = 0.022074
2017-07-05 09:28:36.422327: Step 3980: Validation accuracy = 100.0% (N=100)
2017-07-05 09:28:36.826422: Step 3990: Train accuracy = 100.0%
2017-07-05 09:28:36.826464: Step 3990: Cross entropy = 0.009017
2017-07-05 09:28:36.866917: Step 3990: Validation accuracy = 99.0% (N=100)
2017-07-05 09:28:37.222010: Step 3999: Train accuracy = 99.0%
2017-07-05 09:28:37.222055: Step 3999: Cross entropy = 0.031987
2017-07-05 09:28:37.261577: Step 3999: Validation accuracy = 99.0% (N=100)
Final test accuracy = 99.2% (N=2593)
Converted 2 variables to const ops.

```

We can see from the Listing 3-8 output that we achieve a testing accuracy of 99.2 percent on the cats versus dogs classification problem, reusing the pre-trained InceptionV3 model by just training the weights to the new output layer. This is the power of transfer learning when used within the right context.

Transfer Learning with Pre-trained VGG16

In this section, we will perform transfer learning by using a VGG16 network pre-trained on a thousand classes of ImageNet to classify the cats versus dogs dataset from Kaggle. The link to the dataset is <https://www.kaggle.com/c/dogs-vs-cats/data>. First, we would import the VGG16 model from *TensorFlow Slim* and then load the pre-trained weights in the VGG16 network. The weights are from a VGG16 trained on the thousand classes of the ImageNet dataset. Since for our problem we have only two classes, we will take the output from the last fully connected layer and combine it with a new set of weights, leading to the output layer will one neuron to do a binary classification of the cats and dogs dataset from Kaggle. The idea is to use the pre-trained weights to generate features, and finally we learn just one set of weights at the end, leading to the output. In this way, we learn a relatively small set of weights and can afford to train the model on a smaller amount of data. Please find the detailed implementation in Listing 3-9.

Listing 3-9. Transfer Learning with Pre-trained VGG16

```

import os
import numpy as np
import pandas as pd
import matplotlib.pyplot as plt
import tensorflow as tf
from scipy.misc import imread
from sklearn.model_selection import train_test_split
import cv2
from nets import vgg
from preprocessing import vgg_preprocessing
from mlxtend.preprocessing import shuffle_arrays_unison
sys.path.append("/home/santanu/models/slim")

%matplotlib inline

batch_size = 32
width = 224

```



```

height = 224
cat_train = '/home/santanu/CatvsDog/train/cat/'
dog_train = '/home/santanu/CatvsDog/train/dog/'
checkpoints_dir = '/home/santanu/checkpoints'
slim = tf.contrib.slim

all_images = os.listdir(cat_train) + os.listdir(dog_train)
train_images, validation_images = train_test_split(all_images, train_size=0.8, test_
size=0.2)

MEAN_VALUE = np.array([103.939, 116.779, 123.68])
#####
# Logic to read the images and also do mean correction
#####

def image_preprocess(img_path,width,height):
    img = cv2.imread(img_path)
    img = imresize(img,(width,height))
    img = img - MEAN_VALUE
    return(img)

#####
# Create generator for image batches so that only the batch is in memory
#####

def data_gen_small(images, batch_size, width,height):
    while True:
        ix = np.random.choice(np.arange(len(images)), batch_size)
        imgs = []
        labels = []
        for i in ix:
            data_dir = ' '
            # images
            if images[i].split('.')[0] == 'cat':
                labels.append(1)
                data_dir = cat_train
            else:
                if images[i].split('.')[0] == 'dog':
                    labels.append(0)
                    data_dir = dog_train
            #print 'data_dir',data_dir
            img_path = data_dir + images[i]
            array_img = image_preprocess(img_path,width,height)
            imgs.append(array_img)

        imgs = np.array(imgs)
        labels = np.array(labels)
        labels = np.reshape(labels,(batch_size,1))
        yield imgs,labels

```

```
#####
## Defining the generators for training and validation batches
#####
train_gen = data_gen_small(train_images,batch_size,width,height)
val_gen = data_gen_small(validation_images,batch_size, width,height)

with tf.Graph().as_default():

    x = tf.placeholder(tf.float32,[None,width,height,3])
    y = tf.placeholder(tf.float32,[None,1])

#####
## Load the VGG16 model from slim extract the fully connected layer
## before the final output layer
#####
with slim.arg_scope(vgg.vgg_arg_scope()):
    logits, end_points = vgg.vgg_16(x,
                                    num_classes=1000,
                                    is_training=False)
    fc_7 = end_points['vgg_16/fc7']
#####
## Define the only set of weights that we will learn W1 and b1
#####
Wn =tf.Variable(tf.random_normal([4096,1],mean=0.0,stddev=0.02),name='Wn')
b = tf.Variable(tf.random_normal([1],mean=0.0,stddev=0.02),name='b')

#####
## Reshape the fully connected layer fc_7 and define
## the logits and probability
#####
fc_7 = tf.reshape(fc_7, [-1,W1.get_shape().as_list()[0]])
logitx = tf.nn.bias_add(tf.matmul(fc_7,W1),b1)
probx = tf.nn.sigmoid(logitx)

#####
# Define Cost and Optimizer
# Only we wish to learn the weights Wn and b and hence included them in var_list
#####

cost = tf.reduce_mean(tf.nn.sigmoid_cross_entropy_with_logits(logits=logitx,labels=y))
optimizer = tf.train.AdamOptimizer(learning_rate=learning_rate).minimize(cost,var_
list=[W1,b1])

#####
# Loading the pre-trained weights for VGG16
#####
init_fn = slim.assign_from_checkpoint_fn(
    os.path.join(checkpoints_dir, 'vgg_16.ckpt'),
    slim.get_model_variables('vgg_16'))
```

```
#####
# Running the optimization for only 50 batches of size 32
#####
with tf.Session() as sess:
    init_op = tf.global_variables_initializer()
    sess.run(init_op)
    # Load weights
    init_fn(sess)
    for i in xrange(1):
        for j in xrange(50):
            batch_x, batch_y = next(train_gen)
            #val_x, val_y = next(val_gen)
            sess.run(optimizer, feed_dict={x: batch_x, y: batch_y})
            cost_train = sess.run(cost, feed_dict={x: batch_x, y: batch_y})
            cost_val = sess.run(cost, feed_dict={x: val_x, y: val_y})
            prob_out = sess.run(probx, feed_dict={x: val_x, y: val_y})
            print "Training Cost", cost_train, "Validation Cost", cost_val
            out_val = (prob_out > 0.5)*1
            print 'accuracy', np.sum(out_val == val_y)*100/float(len(val_y))
            plt.imshow(val_x[1] + MEAN_VALUE)
            print "Actual Class:", class_dict[val_y[1][0]]
            print "Predicted Class:", class_dict[out_val[1][0]]
            plt.imshow(val_x[3] + MEAN_VALUE)
            print "Actual Class:", class_dict[val_y[2][0]]
            print "Predicted Class:", class_dict[out_val[2][0]]
```

--output--

```
Training Cost 0.12381 Validation Cost 0.398074
Training Cost 0.160159 Validation Cost 0.118745
Training Cost 0.196818 Validation Cost 0.237163
Training Cost 0.0502732 Validation Cost 0.183091
Training Cost 0.00245218 Validation Cost 0.129029
Training Cost 0.0913893 Validation Cost 0.104865
Training Cost 0.155342 Validation Cost 0.050149
Training Cost 0.00783684 Validation Cost 0.0179586
Training Cost 0.0533897 Validation Cost 0.00746072
Training Cost 0.0112999 Validation Cost 0.00399635
Training Cost 0.0126569 Validation Cost 0.00537223
Training Cost 0.315704 Validation Cost 0.00140141
Training Cost 0.222557 Validation Cost 0.00225646
Training Cost 0.00431023 Validation Cost 0.00342855
Training Cost 0.0266347 Validation Cost 0.00358525
Training Cost 0.0939392 Validation Cost 0.00183608
Training Cost 0.00192089 Validation Cost 0.00105589
Training Cost 0.101151 Validation Cost 0.00049641
Training Cost 0.139303 Validation Cost 0.000168802
Training Cost 0.777244 Validation Cost 0.000357215
Training Cost 2.20503e-06 Validation Cost 0.00628659
Training Cost 0.00145492 Validation Cost 0.0483692
Training Cost 0.0259771 Validation Cost 0.102233
Training Cost 0.278693 Validation Cost 0.11214
```

```
Training Cost 0.0387182 Validation Cost 0.0736753
Training Cost 9.19127e-05 Validation Cost 0.0431452
Training Cost 1.19147 Validation Cost 0.0102272
Training Cost 0.302676 Validation Cost 0.0036657
Training Cost 2.22961e-07 Validation Cost 0.00135369
Training Cost 8.65403e-05 Validation Cost 0.000532816
Training Cost 0.00838018 Validation Cost 0.00029422
Training Cost 0.0604016 Validation Cost 0.000262787
Training Cost 0.648359 Validation Cost 0.000327267
Training Cost 0.00821085 Validation Cost 0.000334495
Training Cost 0.178719 Validation Cost 0.000776928
Training Cost 0.362365 Validation Cost 0.000317593
Training Cost 0.000330557 Validation Cost 0.000139824
Training Cost 0.0879459 Validation Cost 5.76907e-05
Training Cost 0.0881795 Validation Cost 1.21865e-05
Training Cost 1.11339 Validation Cost 1.9081e-05
Training Cost 0.000440863 Validation Cost 3.60468e-05
Training Cost 0.00730334 Validation Cost 6.98846e-05
Training Cost 3.65983e-05 Validation Cost 0.000141883
Training Cost 0.296884 Validation Cost 0.000196292
Training Cost 2.10772e-06 Validation Cost 0.000269568
Training Cost 0.179874 Validation Cost 0.000185331
Training Cost 0.380936 Validation Cost 9.48413e-05
Training Cost 0.0146583 Validation Cost 3.80007e-05
Training Cost 0.387566 Validation Cost 5.26306e-05
Training Cost 7.43922e-06 Validation Cost 7.17469e-05
accuracy 100.0
```

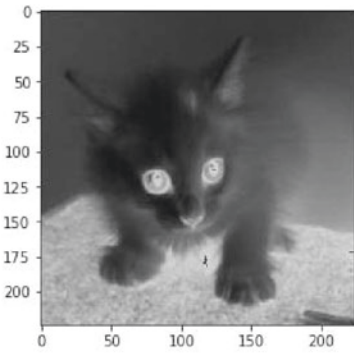

*Actual Class: Cat
Predicted Class: Cat*

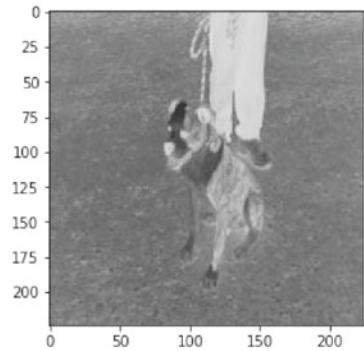

*Actual Class: Dog
Predicted Class: Dog*

Figure 3-35. Validation set images and their actual versus predicted classes

We see that the validation accuracy is 100 percent after training the model on only 50 batches of a moderate size of 32 per batch. The accuracy and the cost are a little noisy since the batch sizes are small, but in general the validation cost is going down while the validation accuracy is on the rise. In Figure 3-35 a couple of validation-set images have been plotted along with their actual and predicted classes to illustrate the correctness of the predictions. Hence, proper utilization of transfer learning helps us to reuse feature detectors learned for one problem in solving a new problem. Transfer learning greatly reduces the number of parameters that need to be learned and hence reduces the computational burden on the network. Also, the training data-size constraints are reduced since fewer parameters require less data in order to be trained.

Summary

In this chapter, we learned about the convolution operation and how it is used to construct a convolutional neural network. Also, we learned about the various key components of CNN and the backpropagation method of training the convolutional layers and the pooling layers. We discussed two critical concepts of CNN responsible for its success in image processing—the equivariance property provided by convolution and the translation invariance provided by the pooling operation. Further, we discussed several established CNN architectures and how to perform transfer learning using the pre-trained versions of these CNNs. In the next chapter, we will discuss recurrent neural networks and their variants in the realm of natural language processing.

CHAPTER 4



Natural Language Processing Using Recurrent Neural Networks

In the modern age of information and analytics, natural language processing (NLP) is one of the most important technologies out there. Making sense of complex structures in language and deriving insights and actions from it is crucial from an artificial-intelligence perspective. In several domains, the importance of natural language processing is paramount and ever growing, as digital information in the form of language is ubiquitous. Applications of natural language processing include language translation, sentiment analysis, web search applications, customer service automation, text classification, topic detection from text, language modeling, and so forth. Traditional methods of natural language processing relied on the Bag of Word models, the Vector Space of Words model, and on-hand coded knowledge bases and ontologies. One of the key areas for natural language processing is the syntactic and semantic analysis of language. Syntactic analysis refers to how words are grouped and connected in a sentence. The main tasks in syntactic analysis are tagging parts of speech, detecting syntactic classes (such as verbs, nouns, noun phrases, etc.), and assembling sentences by constructing syntax trees. Semantics analysis refers to complex tasks such as finding synonyms, performing word-verb disambiguation, and so on.

Vector Space Model (VSM)

In NLP information-retrieval systems, a document is generally represented as simply a vector of the count of the words it contains. For retrieving documents similar to a specific document either the cosine of the angle or the dot product between the document and other documents is computed. The cosine of the angle between two vectors gives a similarity measure based on the similarity between their vector compositions. To illustrate this fact, let us look at two vectors $x, y \in \mathbb{R}^{2 \times 1}$ as shown here:

$$x = [2 \ 3]^T$$
$$y = [4 \ 6]^T$$

Although vectors x and y are different, their cosine similarity is the maximum possible value of 1. This is because the two vectors are identical in their component compositions. The ratio of the first component to the second component for both vectors is $\frac{2}{3}$, and hence content-composition-wise they are treated as being similar. Hence, documents with high cosine similarity are generally considered similar in nature.

Let's say we have two sentences:

$Doc1 = [\textit{The dog chased the cat}]$

$Doc2 = [\textit{The cat was chased down by the dog}]$

The number of distinct words in the two sentences would be the vector-space dimension for this problem. The distinct words are *The, dog, chased, the, cat, down, by,* and *was*, and hence we can represent each document as an eight-dimensional vector of word counts.

'The' 'dog' 'chased' 'the' 'cat' 'down' 'by' 'was'

$Doc1 = [1 \quad 1 \quad 1 \quad 1 \quad 1 \quad 0 \quad 0 \quad 0] \in \mathbb{R}^{8 \times 1}$

$Doc2 = [1 \quad 1 \quad 1 \quad 1 \quad 1 \quad 1 \quad 1 \quad 1] \in \mathbb{R}^{8 \times 1}$

If we represent $Doc1$ by v_1 and $Doc2$ by v_2 , then the cosine similarity can be expressed as

$$\cos(v_1, v_2) = \frac{(v_1^T v_2)}{\|v_1\| \|v_2\|} = \frac{1 \times 1 + 1 \times 1 + 1 \times 1 + 1 \times 1 + 1 \times 1}{\sqrt{5} \sqrt{8}} = \frac{5}{\sqrt{40}}$$

Where $\|v_1\|$ is the magnitude or the l^2 norm of the vector v_1 .

As stated earlier, cosine similarity gives a measure of the similarity based on the component composition of each vector. If the components of the document vectors are in somewhat similar proportion, the cosine distance would be high. It doesn't take the magnitude of the vector into consideration.

In certain cases, when the documents are of highly varying lengths, the dot product between the document vectors is taken instead of the cosine similarity. This is done when, along with the content of the document, the size of the document is also compared. For instance, we can have a tweet in which the words *global* and *economics* might have word counts of 1 and 2 respectively, while a newspaper article might have words counts of 50 and 100 respectively for the same words. Assuming the other words in both documents have insignificant counts, the cosine similarity between the tweet and the newspaper article would be close to 1. Since the tweet sizes are significantly smaller, the word counts proportion of 1:2 for *global* and *economics* doesn't really compare to the proportion of 1:2 for these words in the newspaper article. Hence, it doesn't really make sense to assign such a high similarity measure to these documents for several applications. In that case, taking the dot product as a similarity measure rather than the cosine similarity helps since it scales up the cosine similarity by the magnitude of the word vectors for the two documents. For comparable cosine similarities, documents with higher magnitudes would have higher dot product similarity since they have enough text to justify their word composition. The word composition for small texts might just be by chance and not be the true representation of its intended representation. For most applications where the documents are of comparable lengths, cosine similarity is a fair enough measure.

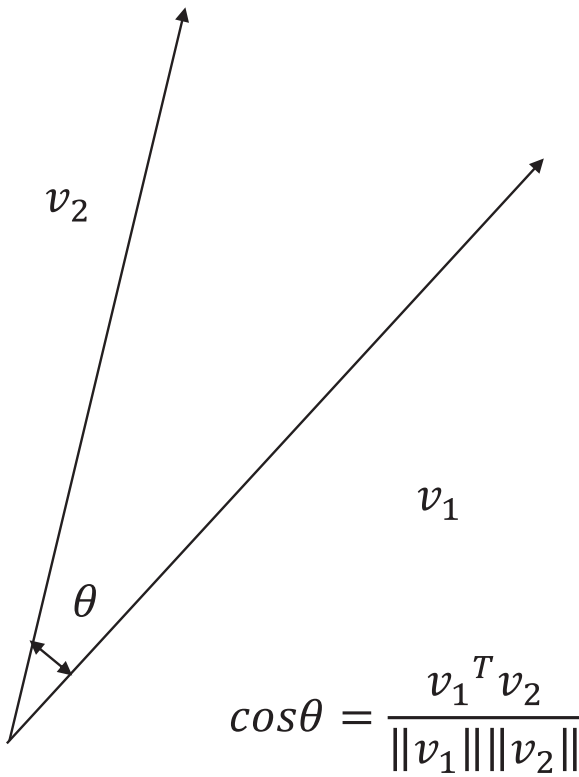

Figure 4-1. Cosine similarity between two word vectors

Figure 4-1 illustrates two vectors v_1 and v_2 with cosine similarity as the cosine of the angle θ between them.

At times, it makes sense to work with the distance counterpart of the cosine similarity. The cosine distance is defined as the square of the Euclidean distance between the unit vectors in the direction of the original vectors for which the distance needs to be computed. For two vectors v_1 and v_2 at an angle of θ between them, the cosine distance is given by $2(1 - \cos\theta)$.

This can be easily deduced by taking the square of the Euclidean distance between the unit vectors $u_1 = \frac{v_1}{\|v_1\|}$ and $u_2 = \frac{v_2}{\|v_2\|}$ as shown here:

$$\begin{aligned} \|u_1 - u_2\|^2 &= (u_1 - u_2)^T (u_1 - u_2) \\ &= u_1^T u_1 + u_2^T u_2 - 2u_1^T u_2 \\ &= \|u_1\|^2 + \|u_2\|^2 - 2\|u_1\| \|u_2\| \cos\theta \end{aligned}$$

Now, u_1 and u_2 being unit vectors, their magnitudes $\|u_1\|$ and $\|u_2\|$ respectively are both equal to 1 and hence

$$\|u_1 - u_2\|^2 = 1 + 1 - 2\cos\theta = 2(1 - \cos\theta)$$

Generally, when working with document term-frequency vectors, the raw term/word counts are not taken and instead are normalized by how frequently the word is used in the corpus. For example, the term *the* is a frequently occurring word in any corpus, and it's likely that the term has a high count in two documents. This high count for *the* is likely to increase the cosine similarity, whereas we know that the term is a frequently occurring word in any corpus and should contribute very little to document similarity. The count of such words in the document term vector is penalized by a factor called *inverse document frequency*.

For a term word t occurring n times in a document d and occurring in N documents out of M documents in the corpus, the normalized count after applying inverse document frequency is

$$\begin{aligned} \text{Normalized count} &= (\text{Term frequency}) \times (\text{Inverse document frequency}) \\ &= n \log \left(\frac{M}{N} \right) \end{aligned}$$

As we can see, as N increases with respect to M , the $\log \left(\frac{M}{N} \right)$ component diminishes until it's zero for $M = N$. So, if a word is highly popular in the corpus then it would not contribute much to the individual document term vector. A word that has high frequency in the document but is less frequent across the corpus would contribute more to the document term vector. This normalizing scheme is popularly known as *tf-idf*, a short-form representation for term frequency inverse document frequency. Generally, for practical purposes, the $(N + 1)$ is taken as a denominator to avoid zeros that make the *log* function undefined. Hence, the inverse document frequency can be rephrased as $\log \left(\frac{M}{N + 1} \right)$

Normalizing schemes are even applied to the term frequency n to make it non-linear. A popular such normalizing scheme is BM25 where the document frequency contribution is linear for small values of n and then the contribution is made to saturate as n increases. The term frequency is normalized as follows in BM25:

$$BM25(n) = \frac{(k + 1)n}{k + n}$$

where k is a parameter that provides different shapes for different values of k and one needs to optimize k based on the corpus.

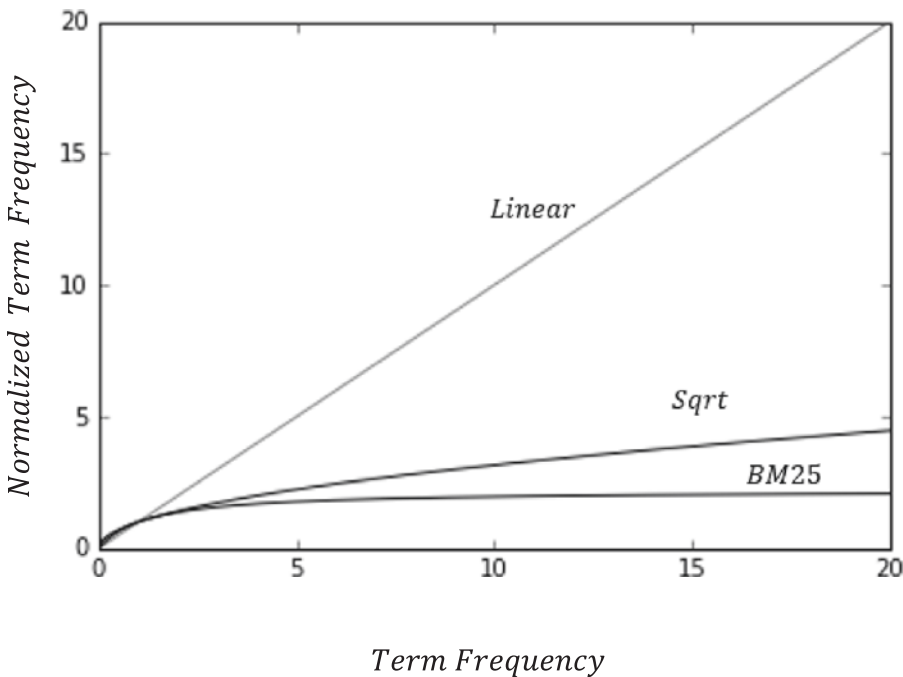

Figure 4-2. Normalized term frequency versus term frequency for different methods

In Figure 4-2, the normalized term frequency for different normalizing schemes has been plotted against the term frequency. Square-root transformation makes the dependency sub-linear, whereas the BM25 plot for $k = 1.2$ is very aggressive and the curve saturates beyond a term frequency of 5. As stated earlier, the k can be optimized through cross-validation or other methods based on the problem needs.

Vector Representation of Words

Just as the documents are expressed as vectors of different word counts, a word in a corpus can also be expressed as a vector, with the components being counts the word has in each document.

Other ways of expressing words as vectors would be to have the component specific to a document set to 1 if the word is present in the document or zero if the word doesn't exist in the document.

$$\begin{array}{l}
 \text{'The' 'dog' 'chased' 'the' 'cat' 'down' 'by' 'was'} \\
 \text{Doc1} = [1 \quad 1 \quad 1 \quad 1 \quad 1 \quad 0 \quad 0 \quad 0] \in \mathbb{R}^{8 \times 1} \\
 \text{Doc2} = [1 \quad 1 \quad 1 \quad 1 \quad 1 \quad 1 \quad 1 \quad 1] \in \mathbb{R}^{8 \times 1}
 \end{array}$$

Reusing the same example the word *The* can be expressed as a two-dimensional vector $[1 \ 1]^T$ in the corpus of two documents. In a huge corpus of documents, the dimensionality of the word vector would be large as well. Like document similarity, word similarity can be computed through either cosine similarity or dot product.

Another way to represent words in a corpus is to one-hot encode them. In that case, the dimensionality of each word would be the number of unique words in the corpus. Each word would correspond to an index that would be set to 1 for the word, and all other remaining entries would be set to 0. So, each would be extremely sparse. Even similar words would have entries set to 1 for different indexes, and hence any kind of similarity measure would not work.

To represent word vectors better so that the similarity of the words can be captured more meaningfully, and also to render less dimensionality to word vectors, Word2Vec was introduced.

Word2Vec

Word2Vec is an intelligent way of expressing a word as a vector by training the word against words in its neighborhood. Words that are contextually like the given word would produce high cosine similarity or dot product when their Word2Vec representations are considered.

Generally, the words in the corpus are trained with respect to the words in their neighborhood to derive the set of the Word2Vec representations. The two most popular methods of extracting Word2Vec representations are the CBOW (Continuous Bag of Words) method and Skip-Gram method. The core idea behind CBOW is expressed in Figure 4-3.

Continuous Bag of Words (CBOW)

The CBOW method tries to predict the center word from the context of the neighboring words in a specific window length. Let’s look at the following sentence and consider a window of five as a neighborhood.

“The cat jumped over the fence and crossed the road”

In the first instance, we will try to predict the word *jumped* from its neighborhood *The cat over the*. In the second instance, as we slide the window by one position, we will try to predict the word *over* from the neighboring words *cat jumped the fence*. This process would be repeated for the entire corpus.

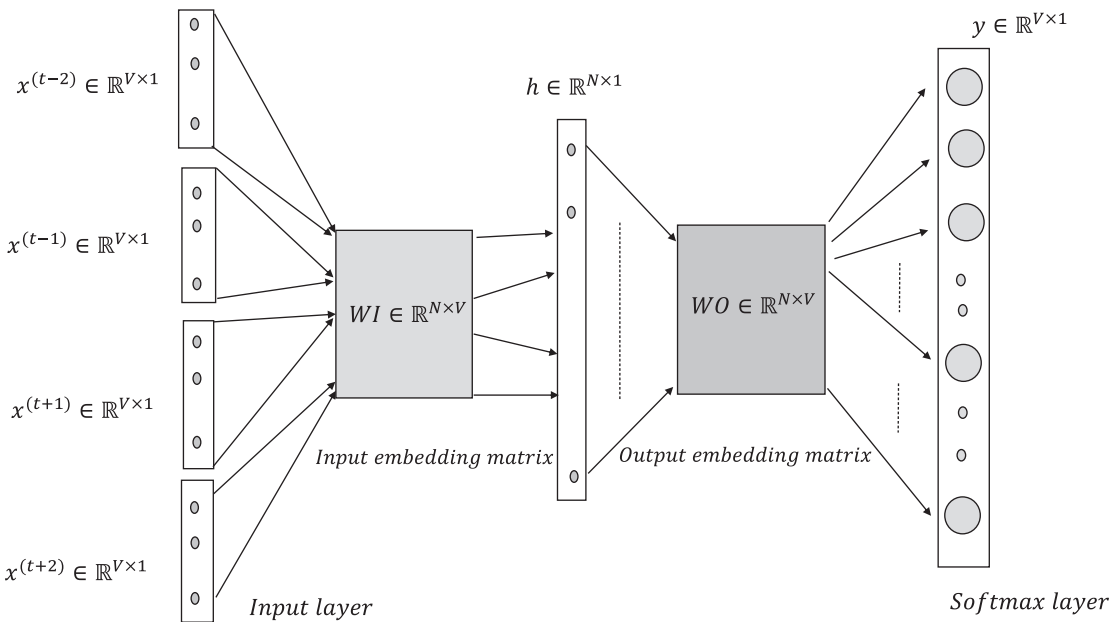

Figure 4-3. Continuous Bag of Words model for word embeddings

As shown in Figure 4-3, the Continuous Bag of Words model (CBOW) is trained on the context words as input and the center word as the output. The words in the input layer are expressed as one-hot encoded vectors where the component for the specific word is set to 1 and all other components are set to 0. The number of unique words V in the corpus determines the dimensionality of these one-hot encoded vectors, and hence $x^{(t)} \in \mathbb{R}^{V \times 1}$. Each one-hot encoded vector $x^{(t)}$ is multiplied by the input embedding matrix $WI \in \mathbb{R}^{N \times V}$ to extract the word-embeddings vector $u^{(k)} \in \mathbb{R}^{N \times 1}$ specific to that word. The index k in $u^{(k)}$ signifies that $u^{(k)}$ is the word embedded for the k th word in the vocabulary. The hidden layer vector h is the average of the input embedding vectors for all the context words in the window, and hence $h \in \mathbb{R}^{N \times 1}$ has the same dimension as that of the word-embedding vectors.

$$h = \frac{1}{l-1} \sum_{\substack{k=(t-2) \\ k \neq t}}^{(t+2)} (WI)x^{(k)}$$

where l is the length of the window size.

Just for clarity, let's say we have a six-word vocabulary—i.e., $V = 6$ —with the words being *cat*, *rat*, *chased*, *garden*, *the*, and *was*.

Let their one-hot encodings occupy the indexes in order so they can be represented as follows:

$$x_{cat} = \begin{bmatrix} 1 \\ 0 \\ 0 \\ 0 \\ 0 \\ 0 \end{bmatrix} \quad x_{rat} = \begin{bmatrix} 0 \\ 1 \\ 0 \\ 0 \\ 0 \\ 0 \end{bmatrix} \quad x_{chased} = \begin{bmatrix} 0 \\ 0 \\ 1 \\ 0 \\ 0 \\ 0 \end{bmatrix} \quad x_{garden} = \begin{bmatrix} 0 \\ 0 \\ 0 \\ 1 \\ 0 \\ 0 \end{bmatrix} \quad x_{the} = \begin{bmatrix} 0 \\ 0 \\ 0 \\ 0 \\ 1 \\ 0 \end{bmatrix} \quad x_{was} = \begin{bmatrix} 0 \\ 0 \\ 0 \\ 0 \\ 0 \\ 1 \end{bmatrix}$$

Let the input embedding where the embedding vector for each word is of dimensionality five be expressed as follows:

$$WI = \begin{matrix} & \begin{matrix} cat & rat & chased & garden & the & was \end{matrix} \\ \begin{matrix} 0.5 & 0.3 & 0.1 & 0.01 & 0.2 & 0.2 \\ 0.7 & 0.2 & 0.1 & 0.02 & 0.3 & 0.3 \\ 0.9 & 0.7 & 0.3 & 0.4 & 0.4 & 0.33 \\ 0.8 & 0.6 & 0.3 & 0.53 & 0.91 & 0.4 \\ 0.6 & 0.5 & 0.2 & 0.76 & 0.6 & 0.5 \end{matrix} \end{matrix}$$

Once we multiply the word-embedding matrix by the one-hot encoded vector for a word, we get the word-embedding vector for that word. Hence, by multiplying the one-hot vector for *cat* (i.e., x_{cat}) by the input embeddings matrix WI , one would get the first column of the WI matrix that corresponds to the *cat*, as shown here:

$$[WI][x_{cat}] = \begin{bmatrix} 0.5 & 0.3 & 0.1 & 0.01 & 0.2 & 0.2 \\ 0.7 & 0.2 & 0.1 & 0.02 & 0.3 & 0.3 \\ 0.9 & 0.7 & 0.3 & 0.4 & 0.4 & 0.33 \\ 0.8 & 0.6 & 0.3 & 0.53 & 0.91 & 0.4 \\ 0.6 & 0.5 & 0.2 & 0.76 & 0.6 & 0.5 \end{bmatrix} \begin{bmatrix} 1 \\ 0 \\ 0 \\ 0 \\ 0 \\ 0 \end{bmatrix} = \begin{bmatrix} 0.5 \\ 0.7 \\ 0.9 \\ 0.8 \\ 0.6 \end{bmatrix}$$

$\begin{bmatrix} 0.5 \\ 0.7 \\ 0.9 \\ 0.8 \\ 0.6 \end{bmatrix}$ is the word-embedding vector for the word *cat*.

Similarly, all the word-embedding vectors for the input words are extracted, and their average is the output of the hidden layer.

The output of the hidden layer h is supposed to represent the embedding of the target word.

All the words in the vocabulary have another set of word embedding housed in the output embedding matrix $WO \in \mathbb{R}^{V \times N}$. Let the word embeddings in WO be represented by $v^{(j)} \in \mathbb{R}^{N \times 1}$, where the index j denotes the j th word in the vocabulary in order as maintained in both the one-hot encoding scheme and the input embedding matrix.

$$WO = \begin{bmatrix} v^{(1)T} \rightarrow \\ v^{(2)T} \rightarrow \\ \cdot \\ v^{(j)T} \rightarrow \\ \cdot \\ v^{(V)T} \rightarrow \end{bmatrix}$$

The dot product of the hidden-layer embedding h is computed with each of the $v^{(j)}$ by multiplying the matrix WO by h . The dot product, as we know, would give a similarity measure for each of the output word embedding $v^{(j)} \forall j \in \{1, 2, \dots, N\}$ and the hidden-layer computed embedding h . The dot products are normalized to probability through a SoftMax and, based on the target word $w^{(t)}$, the categorical cross-entropy loss is computed and backpropagated through gradient descent to update the matrices' weights for both the input and output embedding matrices.

Input to the SoftMax layer can be expressed as follows:

$$[WO][h] = \begin{bmatrix} v^{(1)T} \rightarrow \\ v^{(2)T} \rightarrow \\ \cdot \\ v^{(j)T} \rightarrow \\ \cdot \\ v^{(V)T} \rightarrow \end{bmatrix} [h] = [v^{(1)T}h \quad v^{(2)T}h \quad \dots \quad v^{(j)T}h \quad v^{(V)T}h]$$

The SoftMax output probability for the j th word of the vocabulary $w^{(j)}$ given the context words is given by the following:

$$P(w = w^{(j)} / h) = p^{(j)} = \frac{e^{v^{(j)T}h}}{\sum_{k=1}^V e^{v^{(k)T}h}}$$

If the actual output is represented by a one-hot encoded vector $y = [y_1, y_2, \dots, y_j, \dots, y_n]^T \in \mathbb{R}^{V \times 1}$, where only one of the y_j is 1 (i.e., $\sum_{j=1}^V y_j = 1$), then the loss function for the particular combination of target word and its context words can be given by the following:

$$C = - \sum_{j=1}^V y_j \log(p^{(j)})$$

The different $p^{(j)}$ s are dependent on the input and output embeddings matrices' components, which are parameters to the cost function C . The cost function can be minimized with respect to these embedding parameters through backpropagation gradient-descent techniques.

To make this more intuitive, let's say our target variable is *cat*. If the hidden-layer vector h gives the maximum dot product with the outer matrix word-embeddings vector for *cat* while the dot product with the other outer word embedding is low, then the embedding vectors are more or less correct, and very little error or log loss will be backpropagated to correct the embedding matrices. However, let's say the dot product of h with *cat* is less and that of the other outer embedding vectors is more; the loss of the SoftMax is going to be significantly high, and thus more errors/log loss are going to be backpropagated to reduce the error.

Continuous Bag of Words Implementation in TensorFlow

The Continuous Bag of Words TensorFlow implementation has been illustrated in this section. The neighboring words within a distance of two from either side are used to predict the middle word. The output layer is a big SoftMax over the entire vocabulary. The word embedding vectors are chosen to be of size 128. The detailed implementation is outlined in Listing 4-1a. See also Figure 4-4.

Listing 4-1a. Continuous Bag of Words Implementation in TensorFlow

```
import numpy as np
import tensorflow as tf
from sklearn.manifold import TSNE
import matplotlib.pyplot as plt
%matplotlib inline

def one_hot(ind, vocab_size):
    rec = np.zeros(vocab_size)
    rec[ind] = 1
    return rec

def create_training_data(corpus_raw, WINDOW_SIZE = 2):
    words_list = []

    for sent in corpus_raw.split('.'):

```

```

    for w in sent.split():
        if w != '.':
            words_list.append(w.split('.')[0]) # Remove if delimiter is tied to the
                                                # end of a word

words_list = set(words_list) # Remove the duplicates for each word

word2ind = {} # Define the dictionary for converting
               # a word to index
ind2word = {} # Define dictionary for retrieving a
               # word from its index

vocab_size = len(words_list) # Count of unique words in the
                              # vocabulary

for i,w in enumerate(words_list): # Build the dictionaries
    word2ind[w] = i
    ind2word[i] = w

print word2ind
sentences_list = corpus_raw.split('.')
sentences = []

for sent in sentences_list:
    sent_array = sent.split()
    sent_array = [s.split('.')[0] for s in sent_array]
    sentences.append(sent_array) # finally sentences would hold arrays of
                                # word array for sentences

data_recs = [] # Holder for the input output
               # record

for sent in sentences:
    for ind,w in enumerate(sent):
        rec = []
        for nb_w in sent[max(ind - WINDOW_SIZE, 0) : min(ind + WINDOW_SIZE,
len(sent)) + 1] :
            if nb_w != w:
                rec.append(nb_w)
        data_recs.append([rec,w])

x_train,y_train = [],[]

for rec in data_recs:
    input_ = np.zeros(vocab_size)
    for i in xrange(WINDOW_SIZE-1):
        input_ += one_hot(word2ind[ rec[0][i] ], vocab_size)
    input_ = input_/len(rec[0])
    x_train.append(input_)
    y_train.append(one_hot(word2ind[ rec[1] ], vocab_size))

return x_train,y_train,word2ind,ind2word,vocab_size

```

corpus_raw = "Deep Learning has evolved from Artificial Neural Networks, which has been there since the 1940s. Neural Networks are interconnected networks of processing units called artificial neurons that loosely mimic axons in a biological brain. In a biological neuron, the dendrites receive input signals from various neighboring neurons, typically greater than 1000. These modified signals are then passed on to the cell body or soma of the neuron, where these signals are summed together and then passed on to the axon of the neuron. If the received input signal is more than a specified threshold, the axon will release a signal which again will pass on to neighboring dendrites of other neurons. Figure 2-1 depicts the structure of a biological neuron for reference. The artificial neuron units are inspired by the biological neurons with some modifications as per convenience. Much like the dendrites, the input connections to the neuron carry the attenuated or amplified input signals from other neighboring neurons. The signals are passed on to the neuron, where the input signals are summed up and then a decision is taken what to output based on the total input received. For instance, for a binary threshold neuron an output value of 1 is provided when the total input exceeds a pre-defined threshold; otherwise, the output stays at 0. Several other types of neurons are used in artificial neural networks, and their implementation only differs with respect to the activation function on the total input to produce the neuron output. In Figure 2-2 the different biological equivalents are tagged in the artificial neuron for easy analogy and interpretation."

```
corpus_raw = (corpus_raw).lower()
x_train,y_train,word2ind,ind2word,vocab_size= create_training_data(corpus_raw,2)

import tensorflow as tf
emb_dims = 128
learning_rate = 0.001

#-----
# Placeholders for Input output
#-----
x = tf.placeholder(tf.float32,[None,vocab_size])
y = tf.placeholder(tf.float32,[None,vocab_size])
#-----
# Define the Embedding matrix weights and a bias
#-----
W = tf.Variable(tf.random_normal([vocab_size,emb_dims],mean=0.0,stddev=0.02,dtype=tf.float32))
b = tf.Variable(tf.random_normal([emb_dims],mean=0.0,stddev=0.02,dtype=tf.float32))
W_outer = tf.Variable(tf.random_normal([emb_dims,vocab_size],mean=0.0,stddev=0.02,dtype=tf.float32))
b_outer = tf.Variable(tf.random_normal([vocab_size],mean=0.0,stddev=0.02,dtype=tf.float32))

hidden = tf.add(tf.matmul(x,W),b)
logits = tf.add(tf.matmul(hidden,W_outer),b_outer)
cost = tf.reduce_mean(tf.nn.softmax_cross_entropy_with_logits(logits=logits, labels=y))
optimizer = tf.train.AdamOptimizer(learning_rate=learning_rate).minimize(cost)

epochs,batch_size = 100,10
batch = len(x_train)//batch_size

# train for n_iter iterations
with tf.Session() as sess:
```



```

sess.run(tf.global_variables_initializer())
print 'was here'
for epoch in xrange(epochs):
    batch_index = 0
    for batch_num in xrange(batch):
        x_batch = x_train[batch_index: batch_index +batch_size]
        y_batch = y_train[batch_index: batch_index +batch_size]
        sess.run(optimizer,feed_dict={x: x_batch,y: y_batch})
        print('epoch:',epoch,'loss :', sess.run(cost,feed_dict={x: x_batch,y: y_batch}))
W_embed_trained = sess.run(W)

```

```

W_embedded = TSNE(n_components=2).fit_transform(W_embed_trained)
plt.figure(figsize=(10,10))
for i in xrange(len(W_embedded)):
    plt.text(W_embedded[i,0],W_embedded[i,1],ind2word[i])

plt.xlim(-150,150)
plt.ylim(-150,150)

```

--output--
('epoch:', 99, 'loss :', 1.0895648e-05)

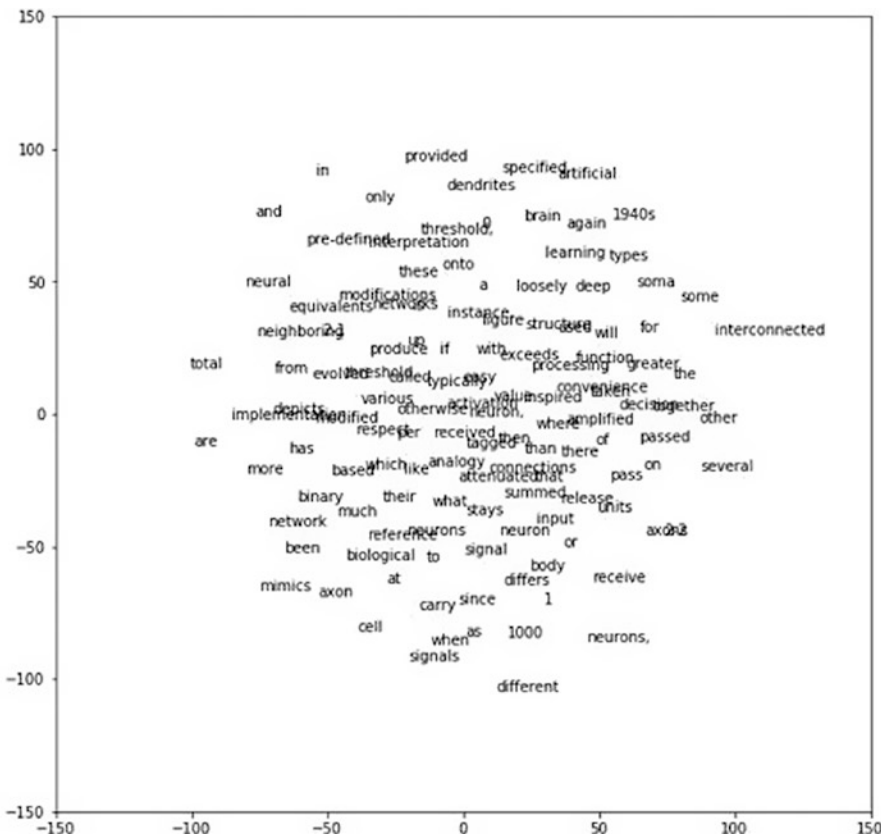

Figure 4-4. TSNE plot for the word-embeddings vectors learned from CBOw

The word embeddings learned have been projected to a 2D plane through the TSNE plot. The TSNE plot gives a rough idea of the neighborhood of a given word. We can see that the word-embeddings vectors learned are reasonable. For instance, the words *deep* and *learning* are very close to each other. Similarly, the words *biological* and *reference* are also very close to each other.

Skip-Gram Model for Word Embedding

Skip-gram models work the other way around. Instead of trying to predict the current word from the context words, as in Continuous Bag of Words, in Skip-gram models the context words are predicted based on the current word. Generally, given a current word, context words are taken in its neighborhood in each window. For a given window of five words there would be four context words that one needs to predict based on the current word. Figure 4-5 shows the high-level design of a Skip-gram model. Much like Continuous Bag of Words, in the Skip-gram model one needs to learn two sets of word embedding: one for the input words and one for the output context words. A Skip-gram model can be seen as a reversed Continuous Bag of Words model.

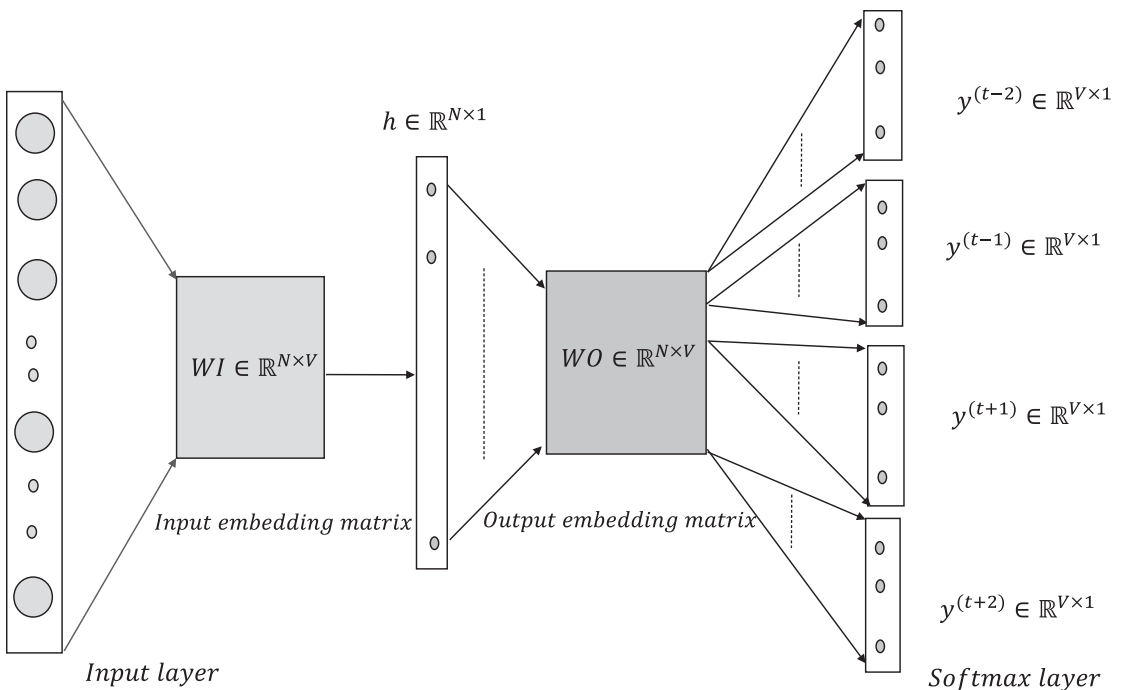

Figure 4-5. Skip-gram model for word embeddings

In the CBOW model the input to the model is a one-hot encoded vector $x^{(t)} \in \mathbb{R}^{V \times 1}$ for the current word, where V is the size of the vocabulary of the corpus. However, unlike CBOW, here the input is the current word and not the context words. The input $x^{(t)}$, when multiplied by the input word-embeddings matrix WI , produces the word-embedding vector $u^{(k)} \in \mathbb{R}^{N \times 1}$ given that $x^{(t)}$ represents the k th word in the vocabulary list. N , as before, represents the word-embeddings dimensionality. The hidden-layer output h is nothing but $u^{(k)}$.

The dot product of the hidden-layer output h is computed with every word vector $v^{(j)}$ of the outer embeddings matrix $WO \in \mathbb{R}^{V \times N}$ by computing $[WO][h]$ just as in CBOW. However, instead of one SoftMax output layer, there are multiple SoftMax layers based on the number of context words that we are going to predict. For example, in Figure 4-5 there are four SoftMax output layers corresponding to the four context words. The input to each of these SoftMax layers is the same set of dot products in $[WO][h]$ representing how similar the input word is to each word in the vocabulary.

$$[WO][h] = [v^{(1)T}h \quad v^{(2)T}h \dots \quad v^{(j)T}h \quad \dots \quad v^{(V)T}h]$$

Similarly, all the SoftMax layers would receive the same set of probabilities corresponding to all the vocabulary words, with the probability of the j th word $w^{(j)}$ given the current or the center word $w^{(k)}$ being given by the following:

$$P(w = w^{(j)} / w = w^{(k)}) = p^{(j)} = \frac{e^{v^{(j)T}h}}{\sum_{k=1}^V e^{v^{(k)T}h}} = \frac{e^{v^{(j)T}w^{(k)}}}{\sum_{k=1}^V e^{v^{(k)T}w^{(k)}}}$$

If there are four target words, and their one-hot encoded vectors are represented by $y^{(t-2)}, y^{(t-1)}, y^{(t+1)}, y^{(t+2)} \in \mathbb{R}^{V \times 1}$, then the total loss function C for the word combination would be the summation of all four SoftMax losses as represented here:

$$C = - \sum_{\substack{m=t-2 \\ m \neq t}}^{t+2} \sum_{j=1}^V y_j^{(m)} \log(p^{(j)})$$

Gradient descent using backpropagation can be used to minimize the cost function and derive the input and output embedding matrices' components.

Here are a few salient features about the Skip-gram and CBOW models:

- For Skip-gram models, the window size is not generally fixed. Given a maximum window size, the window size at each current word is randomly chosen so that smaller windows are chosen more frequently than larger ones. With Skip-gram, one can generate a lot of training samples from a limited amount of text, and infrequent words and phrases are also very well represented.
- CBOW is much faster to train than Skip-gram and has slightly better accuracy for frequent words.
- Both Skip-gram and CBOW look at local windows for word co-occurrences and then try to predict either the context words from the center word (as with Skip-gram) or the center word from the context words (as with CBOW). So, basically, if we observe in Skip-gram that locally within each window the probability of the co-occurrence of the context word w_c and the current word w_p , given by $P(w_c / w_p)$, is assumed to be proportional to the exponential of the dot product of their word-embedding vectors. For example:

$$P(w_c / w_p) \propto e^{u^T v}$$

where u and v are the input and output word-embedding vectors for the current and context words respectively. Since the co-occurrence is measured locally, these models miss utilizing the global co-occurrence statistics for word pairs within certain window lengths. Next, we are going to explore a basic method to look at the global co-occurrence statistics over a corpus and then use SVD (singular value decomposition) to generate word vectors.

Skip-gram Implementation in TensorFlow

In this section, we will illustrate the Skip-gram model for learning word-vector embeddings with a TensorFlow implementation. The model is trained on a small dataset for easy representation. However, the model can be used to train large corpuses as desired. As illustrated in the Skip-gram section, the model is trained as a classification network. However, we are more interested in the word-embeddings matrix than in the actual classification of words. The size of the word embeddings has been chosen to be 128. The detailed code is represented in Listing 4-1b. Once the word-embeddings vectors are learned, they are projected via TSNE on a two-dimensional surface for visual interpretation.

Listing 4-1b. Skip-gram Implementation in TensorFlow

```
import numpy as np
import tensorflow as tf
from sklearn.manifold import TSNE
import matplotlib.pyplot as plt
%matplotlib inline

#-----
# Function to one-hot encode the words
#-----
def one_hot(ind,vocab_size):
    rec = np.zeros(vocab_size)
    rec[ind] = 1
    return rec

#-----
# Function to create the training data from the corpus
#-----
def create_training_data(corpus_raw,WINDOW_SIZE = 2):
    words_list = []

    for sent in corpus_raw.split('.'):
        for w in sent.split():
            if w != '.':
                words_list.append(w.split('.')[0]) # Remove if delimiter is tied to the
                                                    # end of a word

    words_list = set(words_list) # Remove the duplicates for each word

    word2ind = {} # Define the dictionary for converting
                  # a word to index
    ind2word = {} # Define dictionary for retrieving a
                  # word from its index
```

```

vocab_size = len(words_list)                # Count of unique words in the
                                             vocabulary

for i,w in enumerate(words_list):          # Build the dictionaries
    word2ind[w] = i
    ind2word[i] = w

print word2ind
sentences_list = corpus_raw.split('.')
sentences = []

for sent in sentences_list:
    sent_array = sent.split()
    sent_array = [s.split('.')[0] for s in sent_array]
    sentences.append(sent_array)           # finally sentences would hold arrays of
                                         word array for sentences

data_recs = []                            # Holder for the input output record

for sent in sentences:
    for ind,w in enumerate(sent):
        for nb_w in sent[max(ind - WINDOW_SIZE, 0) : min(ind + WINDOW_SIZE,
len(sent)) + 1] :
            if nb_w != w:
                data_recs.append([w,nb_w])

x_train,y_train = [],[]

for rec in data_recs:
    x_train.append(one_hot(word2ind[ rec[0] ], vocab_size))
    y_train.append(one_hot(word2ind[ rec[1] ], vocab_size))

return x_train,y_train,word2ind,ind2word,vocab_size

```

corpus_raw = "Deep Learning has evolved from Artificial Neural Networks which has been there since the 1940s. Neural Networks are interconnected networks of processing units called artificial neurons, that loosely mimics axons in a biological brain. In a biological neuron, the Dendrites receive input signals from various neighboring neurons, typically greater than 1000. These modified signals are then passed on to the cell body or soma of the neuron where these signals are summed together and then passed on to the Axon of the neuron. If the received input signal is more than a specified threshold, the axon will release a signal which again will pass on to neighboring dendrites of other neurons. Figure 2-1 depicts the structure of a biological neuron for reference. The artificial neuron units are inspired from the biological neurons with some modifications as per convenience. Much like the dendrites the input connections to the neuron carry the attenuated or amplified input signals from other neighboring neurons. The signals are passed onto the neuron where the input signals are summed up and then a decision is taken what to output based on the total input received. For instance, for a binary threshold neuron output value of 1 is provided when the total input exceeds a pre-defined threshold, otherwise the output stays at 0. Several other types of neurons are used in artificial neural network and their implementation only differs

with respect to the activation function on the total input to produce the neuron output. In Figure 2-2 the different biological equivalents are tagged in the artificial neuron for easy analogy and interpretation."

```

corpus_raw = (corpus_raw).lower()
x_train,y_train,word2ind,ind2word,vocab_size= create_training_data(corpus_raw,2)

#-----
# Define TensorFlow ops and variable and invoke training
#-----
emb_dims = 128
learning_rate = 0.001
#-----
# Placeholders for Input output
#-----
x = tf.placeholder(tf.float32,[None,vocab_size])
y = tf.placeholder(tf.float32,[None,vocab_size])
#-----
# Define the embedding matrix weights and a bias
#-----
W = tf.Variable(tf.random_normal([vocab_size,emb_dims],mean=0.0,stddev=0.02,dtype=tf.
float32))
b = tf.Variable(tf.random_normal([emb_dims],mean=0.0,stddev=0.02,dtype=tf.float32))
W_outer = tf.Variable(tf.random_normal([emb_dims,vocab_size],mean=0.0,stddev=0.02,dtype=tf.
float32))
b_outer = tf.Variable(tf.random_normal([vocab_size],mean=0.0,stddev=0.02,dtype=tf.float32))

hidden = tf.add(tf.matmul(x,W),b)
logits = tf.add(tf.matmul(hidden,W_outer),b_outer)
cost = tf.reduce_mean(tf.nn.softmax_cross_entropy_with_logits(logits=logits, labels=y))
optimizer = tf.train.AdamOptimizer(learning_rate=learning_rate).minimize(cost)

epochs, batch_size = 100,10
batch = len(x_train)//batch_size

# train for n_iter iterations
with tf.Session() as sess:
    sess.run(tf.global_variables_initializer())
    print 'was here'
    for epoch in xrange(epochs):
        batch_index = 0
        for batch_num in xrange(batch):
            x_batch = x_train[batch_index: batch_index +batch_size]
            y_batch = y_train[batch_index: batch_index +batch_size]
            sess.run(optimizer,feed_dict={x: x_batch,y: y_batch})
            print('epoch:',epoch,'loss :', sess.run(cost,feed_dict={x: x_batch,y: y_batch}))
        W_embed_trained = sess.run(W)
W_embedded = TSNE(n_components=2).fit_transform(W_embed_trained)
plt.figure(figsize=(10,10))
for i in xrange(len(W_embedded)):
    plt.text(W_embedded[i,0],W_embedded[i,1],ind2word[i])

```

```
plt.xlim(-150,150)
plt.ylim(-150,150)

--output--

('epoch:', 99, 'loss :', 1.022735)
```

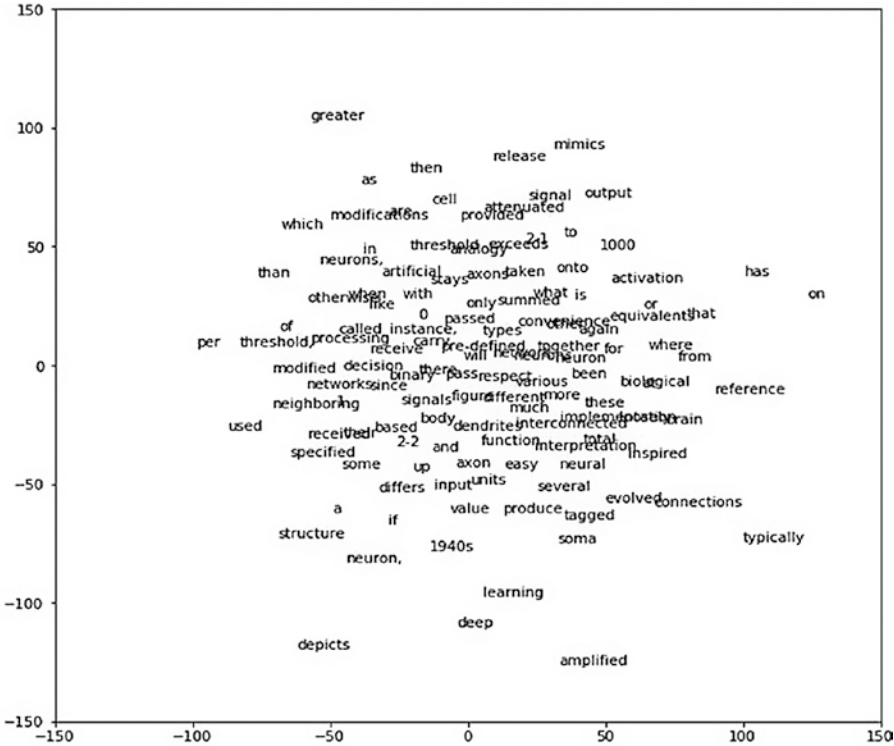

Figure 4-6. TSNE plot of word-embeddings vectors learned from Skip-gram model

Much like the word-embeddings vectors from the Continuous Bag of Words method, the embedding vectors learned from Skip-gram method are reasonable. For instance, the words *deep* and *learning* are very close to each other in Skip-grams too, as we can see from Figure 4-6. Also, we see other interesting patterns, such as the word *attenuated* being very close to the word *signal*.

Global Co-occurrence Statistics–based Word Vectors

The global co-occurrence methods, where the global counts of co-occurrences of words in each window over the whole corpus are collected, can be used to derive meaningful word vectors. Initially, we will look at a method that does matrix factorization through SVD (singular value decomposition) on the global co-occurrence matrix to derive a meaningful lower-dimensional representation of words. Later, we will look at the GloVe technique for word-vector representation, which combines the best of global co-occurrence statistics and the prediction methods of CBOW and/or Skip-gram to represent word vectors.

Let us consider a corpus:

'I like Machine Learning.'
'I like TensorFlow.'
'I prefer Python.'

We first collect the global co-occurrence counts for each word combination within a window of one. While processing the preceding corpus, we will get a co-occurrence matrix. Also, we make the co-occurrence matrix symmetric by assuming that whenever two words w_1 and w_2 appear together it would contribute to both probabilities $P(w_1/w_2)$ and $P(w_2/w_1)$, and hence we increment the count for both the count buckets $c(w_1/w_2)$ and $c(w_2/w_1)$ by one. The term $c(w_1/w_2)$ denotes the co-occurrence of the words w_1 and w_2 , where w_2 acts as the context and w_1 as the word. For word-occurrence pairs, the roles can be reversed so that the context can be treated as the word and the word as the context. For this precise reason, whenever we encounter a co-occurring word pair (w_1, w_2) , both count buckets $c(w_1/w_2)$ and $c(w_2/w_1)$ are incremented.

Coming to the incremental count, we need not always increment by 1 for a co-occurrence of two words. If we are looking at a window of K for populating the co-occurrence matrix, we can define a differential weighting scheme to provide more weight for words co-occurring at less distance from the context and penalize them as the distance increases. One such weighing scheme would be to increment the co-occurrence counter by $\left(\frac{1}{k}\right)$, where k is the offset between the word and the context. When the word and the context are next to each other, then the offset is 1 and the co-occurrence counter can be incremented by 1, while when the offset is at maximum for a window of K the counter increment is at minimum at $\left(\frac{1}{k}\right)$.

In the SVD method of generating the word-vector embedding the assumption is that the global co-occurrence count $c(w_i/w_j)$ between a word w_i and context w_j can be expressed as the dot product of the word-vector embeddings for the word w_i and for the context w_j . Generally, two sets of word embeddings are considered, one for the words and the other for the contexts. If $u_i \in \mathbb{R}^{D \times 1}$ and $v_i \in \mathbb{R}^{D \times 1}$ denote the word vector and the context vector for the i th word w_i in the corpus respectively, then the co-occurrence count can be expressed as follows:

$$c(w_i/w_j) = u_i^T v_j$$

Let's look at a three-word corpus and represent the co-occurrence matrix $X \in \mathbb{R}^{3 \times 3}$ in terms of the dot products of the words and the context vectors. Further, let the words be $w_i, \forall i = \{1, 2, 3\}$ and their corresponding word vectors and context vectors be $u_i, \forall i = \{1, 2, 3\}$ and $v_i, \forall i = \{1, 2, 3\}$ respectively.

$$\begin{aligned} X &= \begin{bmatrix} c(w_1/w_1) & c(w_1/w_2) & c(w_1/w_3) \\ c(w_2/w_1) & c(w_2/w_2) & c(w_2/w_3) \\ c(w_3/w_1) & c(w_3/w_2) & c(w_3/w_3) \end{bmatrix} \\ &= \begin{bmatrix} u_1^T v_1 & u_1^T v_2 & u_1^T v_3 \\ u_2^T v_1 & u_2^T v_2 & u_2^T v_3 \\ u_3^T v_1 & u_3^T v_2 & u_3^T v_3 \end{bmatrix} \\ &= \begin{bmatrix} u_1^T \rightarrow \\ u_2^T \rightarrow \\ u_3^T \rightarrow \end{bmatrix} \begin{bmatrix} v_1 & v_2 & v_3 \end{bmatrix} \\ &= [W][C] \end{aligned}$$

As we can see, the co-occurrence matrix turns out to be the product of two matrices, which are nothing but the word-vector embedding matrices for the words and contexts respectively. The word-vector embedding matrix $W \in \mathbb{R}^{3 \times D}$ and the context-word embeddings matrix $C \in \mathbb{R}^{D \times 3}$, where D is the dimension of the word and context embeddings vectors.

Now that we know that the word co-occurrences matrix is a product of the word-vector embedding matrix and the context embedding matrix, we can factorize the co-occurrence matrix by any applicable matrix factorization technique. Singular value decomposition (SVD) is a well-adopted method because it works, even if the matrices are not square or symmetric.

As we know from SVD, any rectangular matrix X can be decomposed into three matrices U , Σ , and V such that

$$X = [U][\Sigma][V^T]$$

The matrix U is generally chosen as the word-vector embeddings matrix W while ΣV^T is chosen as the context-vector embeddings matrix C , but there is no such restriction, and whichever works well on the given corpus can be chosen. One can very well chose W as $U\Sigma^{1/2}$ and C as $\Sigma^{1/2}V^T$. Generally, fewer dimensions in the data based on the significant singular values are chosen to reduce the size of U , Σ , and V . If $X \in \mathbb{R}^{m \times n}$, then $U \in \mathbb{R}^{m \times m}$. However, with truncated SVD we take only a few significant directions along which the data has maximum variability and ignore the rest as insignificant and/or noise. If we chose D dimensions, the new word-vector embeddings matrix $U' \in \mathbb{R}^{m \times D}$, where D is the dimension of every word-vector embedding.

The co-occurrence matrix $X \in \mathbb{R}^{m \times n}$ is generally obtained in a more generalized setting by making a pass through the entire corpus once. However, since the corpus might get new documents or contents over time, those new documents or contents can be processed incrementally. Figure 4-7 below illustrates the derivation of the word vectors or word embeddings in a three-step process.

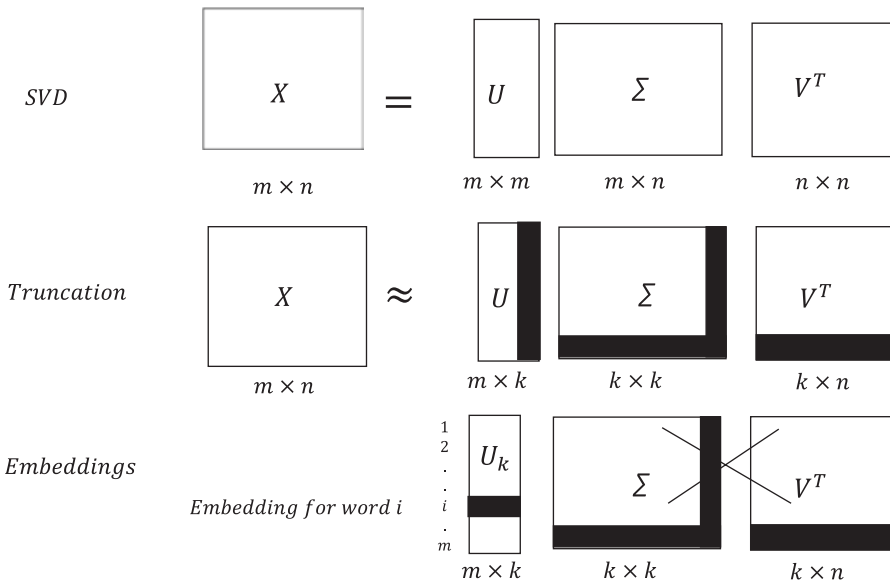

Figure 4-7. Extraction of word embeddings through SVD of word co-occurrence matrix

- In the first step, singular value decomposition (SVD) is performed on the co-occurrence matrix $X \in \mathbb{R}^{m \times n}$ to produce $U \in \mathbb{R}^{m \times m}$, which contains the left singular vectors, $\Sigma \in \mathbb{R}^{m \times n}$, which contains the singular values, and $V \in \mathbb{R}^{n \times n}$, which contains the right singular vectors.

$$[X]_{m \times n} = [U]_{m \times m} [\Sigma]_{m \times n} [V^T]_{n \times n}$$

- Generally, for word-to-word co-occurrence matrices, the dimensions m and n should be equal. However, sometimes instead of expressing words by words, words are expressed by contexts, and hence for generalization we have taken separate m and n .
- In the second step, the co-occurrence matrix is approximated by taking only k significant singular values from Σ that explain the maximum variance in data and by also choosing the corresponding k left singular and right singular vectors in U and V .

$$\text{If we start with } U = [u_1 u_2 \dots u_m], \Sigma = \begin{bmatrix} \sigma_1 & \dots & 0 \\ \vdots & \ddots & \vdots \\ 0 & \dots & \sigma_m \end{bmatrix}, V^T = \begin{bmatrix} v_1^T \rightarrow \\ v_2^T \rightarrow \\ \dots \\ v_n^T \rightarrow \end{bmatrix}$$

after truncation, we would have

$$U' = [u_1 u_2 \dots u_k], \Sigma' = \begin{bmatrix} \sigma_1 & \dots & 0 \\ \vdots & \ddots & \vdots \\ 0 & \dots & \sigma_k \end{bmatrix}, V'^T = \begin{bmatrix} v_1^T \rightarrow \\ v_2^T \rightarrow \\ \dots \\ v_k^T \rightarrow \end{bmatrix}$$

- In the third step, Σ' and V'^T are discarded and the matrix $U' \in \mathbb{R}^{m \times k}$ is taken to be the word-embeddings vector matrix. The word vectors have k dense dimensions corresponding to the chosen k singular values. So, from a sparse co-occurrence matrix we get a dense representation of the word-vector embeddings. There would be m word embeddings corresponding to each word of the processed corpus.

Mentioned in Listing 4-1c is the logic for building word vectors from a given corpus by factorizing the co-occurrence matrix of different words through SVD. Accompanying the listing is the plot of the derived word-vector embeddings in Figure 4-8.

Listing 4-1c.

```
import numpy as np

corpus = ['I like Machine Learning.', 'I like TensorFlow.', 'I prefer Python.']

corpus_words_unique = set()

corpus_processed_docs = []
for doc in corpus:
    corpus_words_ = []
    corpus_words = doc.split()
    print corpus_words
    for x in corpus_words:
        if len(x.split('.')) == 2:
            corpus_words_ += [x.split('.')[0]] + ['.']
        else:
            corpus_words_ += x.split('.')
    corpus_processed_docs.append(corpus_words_)
    corpus_words_unique.update(corpus_words_)
```

```

corpus_words_unique = np.array(list(corpus_words_unique))

co_occurrence_matrix = np.zeros((len(corpus_words_unique),len(corpus_words_unique)))
for corpus_words_ in corpus_processed_docs:
    for i in xrange(1,len(corpus_words_)) :

        index_1 = np.argwhere(corpus_words_unique == corpus_words_[i])
        index_2 = np.argwhere(corpus_words_unique == corpus_words_[i-1])

        co_occurrence_matrix[index_1,index_2] += 1
        co_occurrence_matrix[index_2,index_1] += 1

U,S,V = np.linalg.svd(co_occurrence_matrix,full_matrices=False)
print 'co_occurrence_matrix follows:'
print co_occurrence_matrix
import matplotlib.pyplot as plt
for i in xrange(len(corpus_words_unique)):
    plt.text(U[i,0],U[i,1],corpus_words_unique[i])
plt.xlim((-0.75,0.75))
plt.ylim((-0.75,0.75))
plt.show()

```

--output--

```

co_occurrence_matrix follows:
[[ 0.  2.  0.  0.  1.  0.  0.  1.]
 [ 2.  0.  1.  0.  0.  0.  0.  0.]
 [ 0.  1.  0.  0.  0.  1.  0.  0.]
 [ 0.  0.  0.  0.  0.  1.  1.  1.]
 [ 1.  0.  0.  0.  0.  0.  1.  0.]
 [ 0.  0.  1.  1.  0.  0.  0.  0.]
 [ 0.  0.  0.  1.  1.  0.  0.  0.]
 [ 1.  0.  0.  1.  0.  0.  0.  0.]]

```

Word-Embeddings Plot

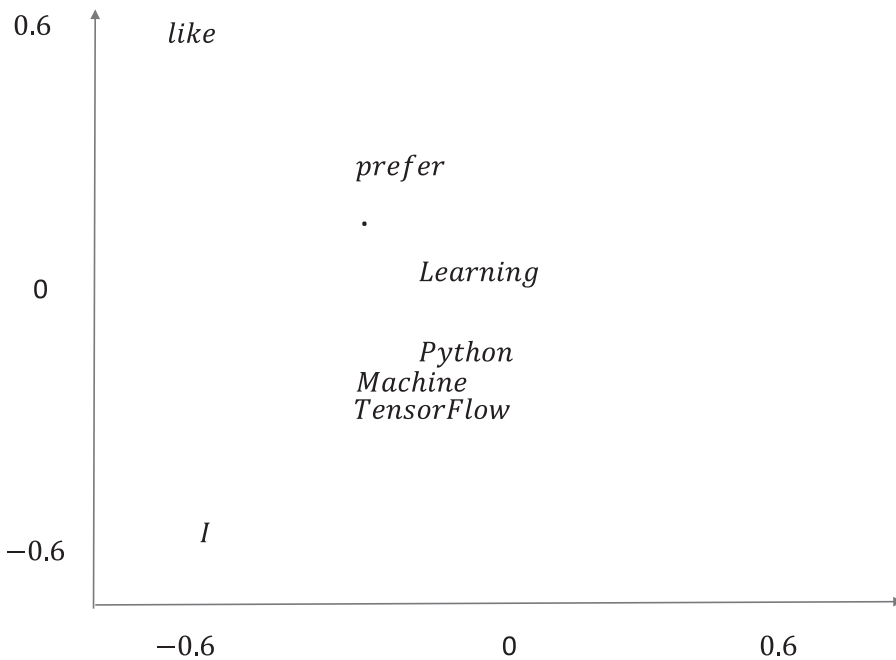

Figure 4-8. Word-embeddings plot

We can see a clear pattern in the plot of the word-vectors embedding in Figure 4-8, even with this small corpus. Here are a few of the findings:

- Common words like *I* and *like* are far away from others.
- *Machine*, *Learning*, *Python* and *Tensorflow*, being associated with different areas of learning, are clustered close to each other.

Next, we move on to global vectors, commonly known as GloVe, for generating word-vector embeddings.

GloVe

GloVe is a pre-trained, readily available word embedding vectors library from Stanford University. The training method for GloVe is significantly different from those for CBOW and Skip-gram. Instead of basing predictions on local-running windows for words, GloVe uses global word-to-word co-occurrence statistics from a corpus to train the model and derive the GloVe vectors. GloVe stands for *global vectors*. Pre-trained GloVe word embeddings are available at <https://nlp.stanford.edu/projects/glove/>. Jeffrey Pennington, Richard Socher, and Christopher D. Manning are the inventors of GloVe vectors, and they have documented GloVe vectors in their paper titled “GloVe: Global Vectors for Word Representation.” The paper can be located at <https://nlp.stanford.edu/pubs/glove.pdf>.

Like SVD methods, GloVe looks at the global co-occurrence statistics, but the relation of the word and context vectors with respect to the co-occurrences count is a little different. If there are two words w_i and w_j and a context word w_k , then the ratio of the probabilities $P(w_k/w_i)$ and $P(w_k/w_j)$ provide more information than the probabilities themselves.

Let's consider two words, $w_i = \text{"garden"}$ and $w_j = \text{"market"}$, and a couple of context words, $w_k \in \{\text{"plants"}, \text{"shops"}\}$. The individual co-occurrences probability might be low; however, if we take the ratio of the co-occurrences probabilities, for instance

$$\frac{P(w_k = \text{"plants"} / w_i = \text{"garden"})}{P(w_k = \text{"plants"} / w_j = \text{"market"})}$$

The preceding ratio is going to be much greater than one indicating that *plants* are much more likely to be associated with *garden* than with *market*.

Similarly, let's consider $w_k = \text{"shops"}$ and look at the ratio of the following co-occurrence probability:

$$\frac{P(w_k = \text{"shops"} / w_i = \text{"garden"})}{P(w_k = \text{"shops"} / w_j = \text{"market"})}$$

In this case, the ratio is going to be very small, signifying that the word *shop* is much more likely to be associated with the word *market* than with *garden*.

Hence, we can see that the ratio of the co-occurrence probabilities provides much more discrimination between words. Since we are trying to learn word vectors, this discrimination should be encoded by the difference of the word vectors, as in a linear vector space that's the best way to represent the discrimination between vectors. Similarly, the most convenient way to represent the similarity between vectors in a linear vector space is to consider their dot product, and hence the co-occurrence probability would be well represented by some function of the dot product between the word and the context vector. Taking all this into consideration helps one derive the logic for the GloVe vector derivation on a high level.

If u_i, u_j are the word-vector embeddings for the words w_i and w_j , and v_k is the context vector for word w_k , then the ratio of the two co-occurrence probabilities can be expressed as some function of the difference of the word vectors (i.e., $(u_i - u_j)$) and the context vector v_k . A logical function should work on the dot product of the difference of the word vector and the context vector, primarily because it preserves the linear structure between the vectors before it is manipulated by the function. Had we not taken the dot product, the function could have worked on the vectors in a way that would have disrupted the linear structure. Based on the preceding explanation, the ratio of the two co-occurrence probabilities can be expressed as follows:

$$\frac{P(w_k / w_i)}{P(w_k / w_j)} = f\left((u_i - u_j)^T v_k\right) \quad (4.1.1)$$

Where f is a given function that we seek to find out.

Also, as discussed, the co-occurrence probability $P(w_k / w_i)$ should be encoded by some form of similarity between vectors in a linear vector space, and the best operation to do so is to represent the co-occurrence probability by some function g of the dot product between the word vector w_i and context vector w_k , as expressed here:

$$P\left(\frac{w_k}{w_i}\right) = g(u_i^T v_k) \quad (4.1.2)$$

Combining (4.1.1) and (4.1.2), we have

$$\frac{g(u_i^T v_k)}{g(u_j^T v_k)} = f((u_i - u_j)^T v_k) \quad (4.1.3)$$

Now the task is to determine meaningful functions f and g for the preceding equation to make sense. If we choose f and g to be the exponential function, it enables the ratio of the probabilities to encode the difference of the word vectors and at the same time keeps the co-occurrence probability dependent on the dot product. The dot product and difference of vectors keep the notion of similarity and discrimination of vectors in a linear space. Had the functions f and g been some kind of kernel functions then the measure of similarity and dissimilarity wouldn't have been restricted to a linear vector space and would have made the interpretability of word vectors very difficult.

Replacing f and g with the exponential function in (4.1.3), we get

$$\frac{e^{(u_i^T v_k)}}{e^{(u_j^T v_k)}} = e^{(u_i - u_j)^T v_k}$$

which gives us

$$P(w_k / w_i) = e^{u_i^T v_k} \Rightarrow \log P(w_k / w_i) = u_i^T v_k \quad (4.1.4)$$

Interested readers with some knowledge of group theory in abstract algebra can see that the function $f(x) = e^x$ has been chosen so as to define a group homomorphism between the groups $(\mathbb{R}, +)$ and (\mathbb{R}^+, \times) .

The co-occurrence probability of the word w_i and the context word w_k can be denoted as follows:

$$P(w_k / w_i) = \frac{c(w_i, w_k)}{c(w_i)} \quad (4.1.5)$$

where $c(w_i, w_k)$ denotes the co-occurrence count of word w_i with the context word w_k and $c(w_i)$ denotes the total occurrences of the word w_i . The total count of any word can be computed by summing up its co-occurrences count with all other words in the corpus, as shown here:

$$c(w_i) = \sum_k c(w_i, w_k)$$

Combining (4.1.4) and (4.1.5), we get

$$\log c(w_i, w_k) - \log c(w_i) = u_i^T v_k$$

$\log c(w_i)$ can be expressed as a bias b_i for the word w_i , and an additional bias \tilde{b}_k for the word w_k is also introduced to make the equation symmetric. So, the final relation can be expressed as

$$\log c(w_i, w_k) = u_i^T v_k + \tilde{b}_k + b_i$$

Just as we have two sets of word-vector embeddings, similarly we see two sets of bias—one for context words given by \tilde{b}_i and the other for words given by b_i , where i indicates the i th word of the corpus.

The final aim is to minimize a sum of the squared error cost function between the actual $\log c(w_i, w_k)$ and the predicted $u_i^T v_k + \tilde{b}_k + b_i$ for all word-context pairs, as follows:

$$C(U, V, \tilde{B}, B) = \sum_{i,j=1}^V (u_i^T v_k + \tilde{b}_k + b_i - \log c(w_i, w_k))^2$$

U and V are the set of parameters for the word-vector embeddings and context-vector embeddings. Similarly, \tilde{B} and B are the parameters for the biases corresponding to the words and the contexts. The cost function $C(U, V, \tilde{B}, B)$ must be minimized with respect to these parameters in U, V, \tilde{B}, B .

One issue with this scheme of least square method is that it weights all co-occurrences equally in the cost function. This prevents the model from achieving good results since the rare co-occurrences carry very little information. One of the ways to handle this issue is to assign more weight to co-occurrences that have a higher count. The cost function can be modified to have a weight component for each co-occurrence pair that is a function of the co-occurrences count. The modified cost function can be expressed as follows:

$$C(U, V, \tilde{B}, B) = \sum_{i,j=1}^V h(c(w_i, w_k)) (u_i^T v_k + \tilde{b}_k + b_i - \log c(w_i, w_k))^2$$

where h is the newly introduced function.

The function $h(x)$ (see Figure 4-9) can be chosen as follows:

$$h(x) = \left(\frac{x}{x_{\max}} \right)^\alpha \quad \text{if } x < x_{\max}$$

$$= 1, \text{ elsewhere}$$

One can experiment with different values of α , which acts as a hyper parameter to the model.

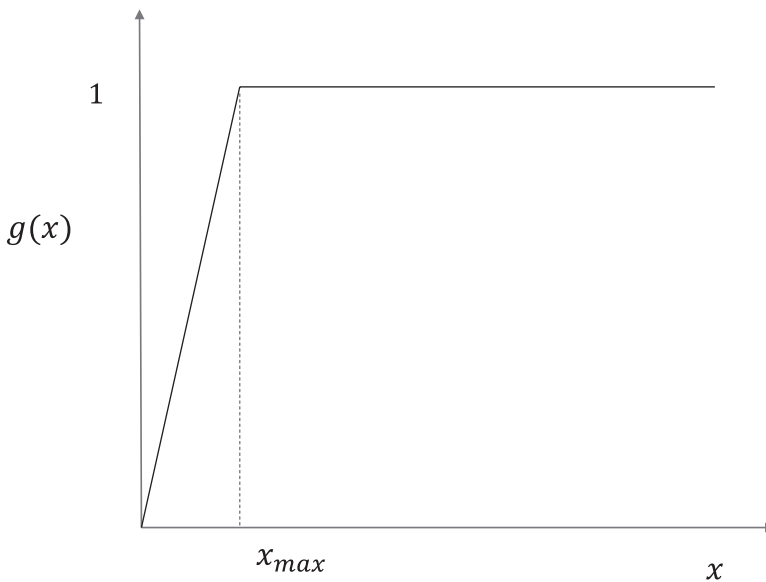

Figure 4-9. Weightage function for the co-occurrence counts

Word Analogy with Word Vectors

The good thing about word-vector embedding lies in its abilities to linearize analogies. We look at some analogies using the pre-trained GloVe vectors in Listing 4-2a, Listing 4-2b, and Listing 4-3c.

Listing 4-2a.

```
import numpy as np
import scipy
from sklearn.manifold import TSNE
import matplotlib.pyplot as plt
%matplotlib inline
#####
# Loading glove vector
#####
EMBEDDING_FILE = '~/Downloads/glove.6B.300d.txt'

print('Indexing word vectors')
embeddings_index = {}
f = open(EMBEDDING_FILE)
count = 0
for line in f:
    if count == 0:
        count = 1
        continue
    values = line.split()
    word = values[0]
    coefs = np.asarray(values[1:], dtype='float32')
    embeddings_index[word] = coefs
```



```
f.close()

print('Found %d word vectors of glove.' % len(embeddings_index))

-- output --
```

```
Indexing word vectors
Found 399999 word vectors of glove.
```

Listing 4-2b.

```
king_wordvec = embeddings_index['king']
queen_wordvec = embeddings_index['queen']
man_wordvec   = embeddings_index['man']
woman_wordvec = embeddings_index['woman']

pseudo_king = queen_wordvec - woman_wordvec + man_wordvec
cosine_simi = np.dot(pseudo_king/np.linalg.norm(pseudo_king),king_wordvec/np.linalg.
norm(king_wordvec))
print 'Cosine Similarity',cosine_simi
--output --
Cosine Similarity 0.663537
```

Listing 4-2c.

```
tsne = TSNE(n_components=2)
words_array = []
word_list = ['king','queen','man','woman']
for w in word_list:
    words_array.append(embeddings_index[w])
index1 = embeddings_index.keys()[0:100]
for i in xrange(100):
    words_array.append(embeddings_index[index1[i]])
words_array = np.array(words_array)
words_tsne = tsne.fit_transform(words_array)

ax = plt.subplot(111)
for i in xrange(4):
    plt.text(words_tsne[i, 0], words_tsne[i, 1],word_list[i])
    plt.xlim((-50,20))
    plt.ylim((0,50))

--output--
```

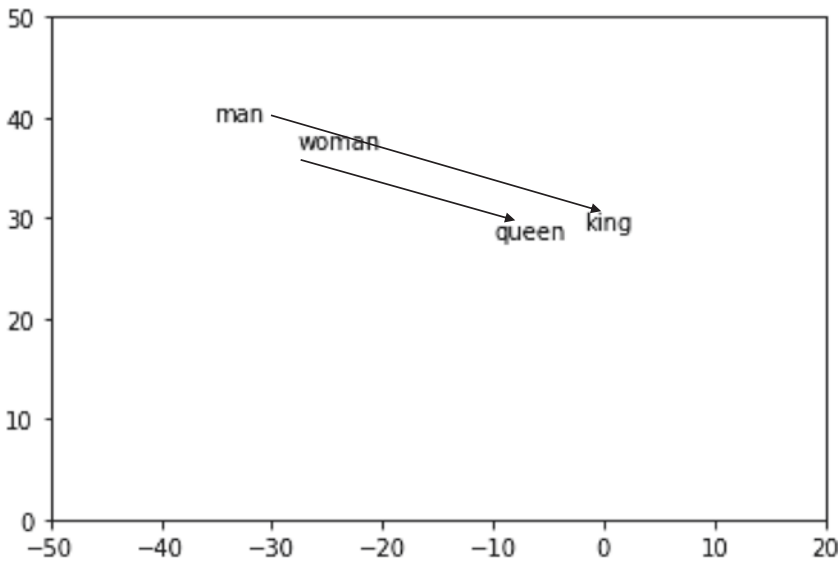

Figure 4-10. 2D TSNE vector plot for pre-trained GloVe vectors

In Listing 4-2a, the pre-trained GloVe vectors of dimensionality 300 are loaded and stored in a dictionary. We play around with the GloVe vectors for the words *king*, *queen*, *man*, and *woman* to find an analogy. Taking the word vectors for *queen*, *man*, and *woman*, a word vector *pseudo_king* is created as follows:

$$pseudo_king = queen - woman + man$$

The idea is to see whether the preceding created vector somewhat represents the concept of *king* or not. The cosine of the angle between the word vectors *pseudo_king* and *king* is high at around 0.67, which is an indication that $(queen - woman + man)$ very well represents the concept of *king*.

Next, in Listing 4-2c, we try to represent an analogy, and for that purpose, through TSNE, we represent the GloVe vectors of dimensionality 300 in a two-dimensional space. The results have been plotted in Figure 4-10. We can see that the word vectors for *king* and *queen* are close to each other and clustered together, and the word vectors for *man* and *woman* are clustered close to each other as well. Also, we see that the vector differences between *king* and *man* and those between *queen* and *woman* are almost parallel and of comparable lengths.

Before we move on to recurrent neural networks, one thing I want to mention is the importance of word embeddings for recurrent neural networks in the context of natural language processing. A recurrent neural network doesn't understand text, and hence each word in the text needs to have some form of number representation. Word-embeddings vectors are a great choice since words can be represented by multiple concepts given by the components of the word-embeddings vector. Recurrent neural networks can be made to work both ways, either by providing the word-embeddings vectors as input or by letting the network learn those embeddings vectors by itself. In the latter case, the word-embeddings vectors would be aligned more toward the ultimate problem's being solved through the recurrent neural network. However, at times the recurrent neural network might have a lot of other parameters to learn, or the network might have very little data to train on. In such cases, having to learn the word-embeddings vectors as parameters might lead to overfitting or sup-optimal results. Using the pre-trained word-vector embeddings might be a wiser option in such scenarios.

Introduction to Recurrent Neural Networks

Recurrent neural networks (RNNs) are designed to utilize and learn from sequential information. The RNN architecture is supposed to perform the same task for every element of a sequence, and hence the term *recurrent* in its nomenclature. RNNs have been of great use in the task of natural language processing because of the sequential dependency of words in any language. For example, in the task of predicting the next word in a sentence, the prior sequence of words that came before it is of paramount importance. Generally, at any time step of a sequence, RNNs compute some memory based on its computations thus far; i.e., prior memory and the current input. This computed memory is used to make predictions for the current time step and is passed on to the next step as an input. The basic architectural principal of a recurrent neural network is illustrated in Figure 4-11.

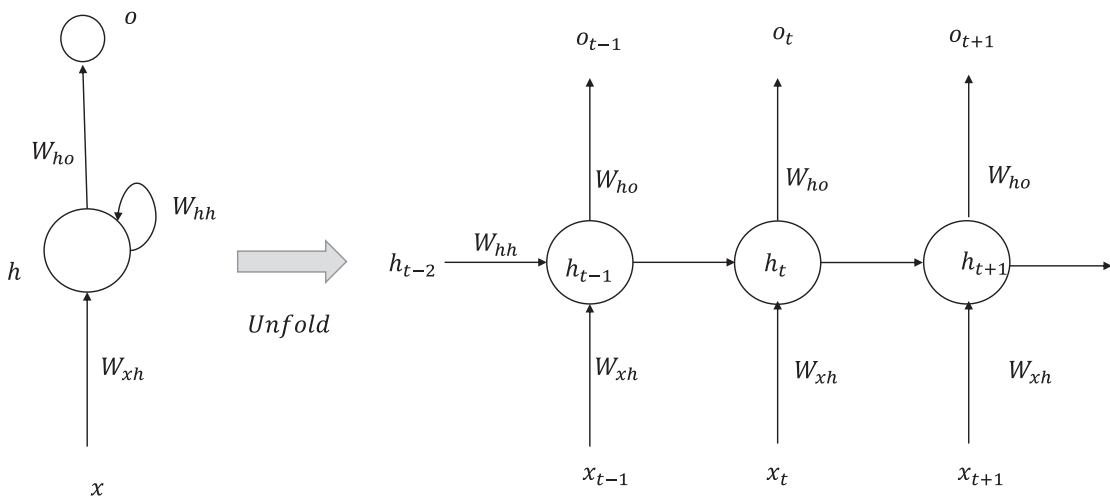

Figure 4-11. Folded and unfolded structure of an RNN

In Figure 4-11, the RNN architecture has been unrolled in time to depict the complete sequence. If we wish to process seven-word sequences of sentences, then the unfolded RNN architecture would represent a seven-layer feed-forward neural network, with the only difference being that the weights at each layer are common shared weights. This significantly reduces the number of parameters to learn in a recurrent neural network.

Just to get us familiar with the notations used, x_t , h_t , and o_t represent the input, computed memory or hidden states, and output respectively at time step t . W_{hh} represents the weights matrix from the memory states h_t at time t to the memory states h_{t+1} at time $(t+1)$. W_{xh} represents the weight matrix from the input x_t to the hidden states h_t , whereas W_{ho} represents the weight matrix from the memory states h_t to o_t . The weight matrix W_{xh} acts as some sort of word-vector embeddings matrix when the inputs are presented in a one-hot encoded form. Alternately, in cases of one-hot encoded inputs one may choose to have a learnable separate embedding matrix so that when the one-hot encoded input vector passes through the embeddings layer its desired embeddings vector is presented as an output.

Now, let's drill down to each component in detail:

- The input x_t is a vector representing the input word at step t . For example, it can be a one-hot encoded vector with the component set to 1 for the corresponding word index in the vocabulary. It can also be the word-vector embedding from some pre-trained repository such as GloVe. In general, we assume $x_t \in \mathbb{R}^{D \times 1}$. Also, if we are looking to predict V classes then the output $y_t \in \mathbb{R}^{V \times 1}$.
- The memory or the hidden state vector h_t can have any length as per the user's choice. If the number of states chosen is n then $h_t \in \mathbb{R}^{n \times 1}$ and the weight matrix $W_{hh} \in \mathbb{R}^{n \times n}$.
- The weight matrix connecting the input to the memory states $W_{xh} \in \mathbb{R}^{n \times D}$ and the weight matrix connecting the memory states to the output $W_{ho} \in \mathbb{R}^{n \times V}$.
- The memory h_t at step t is computed as follows:

$h_t = f(W_{hh}h_{t-1} + W_{xh}x_t)$, where f is a chosen non-linear activation function.

The dimension of $(W_{hh}h_{t-1} + W_{xh}x_t)$ is n ; i.e., $(W_{hh}h_{t-1} + W_{xh}x_t) \in \mathbb{R}^{n \times 1}$.

The function f works element-wise on $(W_{hh}h_{t-1} + W_{xh}x_t)$ to produce h_t , and hence

$(W_{hh}h_{t-1} + W_{xh}x_t)$ and h_t have the same dimension.

If $W_{hh}h_{t-1} + W_{xh}x_t = \begin{bmatrix} s_{1t} \\ s_{2t} \\ \cdot \\ \cdot \\ s_{nt} \end{bmatrix}$, then the following holds true for h_t :

$$h_t = \begin{bmatrix} f(s_{1t}) \\ f(s_{2t}) \\ \cdot \\ \cdot \\ f(s_{nt}) \end{bmatrix}$$

- The connections from the memory states to the output are just like the connections from a fully connected layer to the output layer. When a multi-class classification problem is involved, such as predicting the next word, then the output layer would be a huge SoftMax of the number of words in the vocabulary. In such cases the predicted output vector $o_t \in \mathbb{R}^{V \times 1}$ can be expressed as $SoftMax(W_{ho}h_t)$. Just to keep the notations simple, the biases have not been mentioned. In every unit, we can add bias to the input before it is acted upon by the different functions. So, o_t can be represented as

$$o_t = SoftMax(W_{ho}h_t + b_o)$$

where $b_o \in \mathbb{R}^{n \times 1}$ is the bias vector for the output units.

- Similarly, bias can be introduced in the memory units, and hence h_t can be expressed as

$$h_t = f(W_{hh}h_{t-1} + W_{xh}x_t + b_h)$$

where $b_h \in \mathbb{R}^{n \times 1}$ is the bias vector at the memory units.

- For a classification problem predicting the next word for a text sequence of T time steps, the output at each time step is a big SoftMax of V classes, where V is the size of the vocabulary. So, the corresponding loss at each time step is the negative log loss over all the vocabulary size V . The loss at each time step can be expressed as follows:

$$C_t = - \sum_{j=1}^V y_t^{(j)} \log o_t^{(j)}$$

- To get the overall loss over all the time steps T , all such C_t needs to be summed up or averaged out. Generally, the average of all C_t is more convenient for stochastic gradient descent so as to get a fair comparison when the sequence length varies. The overall cost function for all the time steps T can thus be represented by the following:

$$C = - \sum_{t=1}^T \sum_{j=1}^V y_t^{(j)} \log o_t^{(j)}$$

Language Modeling

In language modeling, the probability of a sequence of words is computed through the product rule of intersection of events. The probability of a sequence of words $w_1 w_2 w_3 \dots w_n$ of length n is given as follows:

$$\begin{aligned} P(w_1 w_2 w_3 \dots w_n) &= P(w_1) P(w_2 / w_1) P(w_3 / w_1 w_2) \dots P(w_n / w_1 w_2 \dots w_{n-1}) \\ &= P(w_1) \prod_{k=2}^n P(w_k / w_1 w_2 \dots w_{k-1}) \end{aligned}$$

In traditional approaches, the probability of a word at time step k is generally not conditioned on the whole sequence of length $(k-1)$ prior to that but rather on a small window L prior to t . Hence, the probability is generally approximated as follows:

$$P(w_1 w_2 w_3 \dots w_n) \cong P(w_1) \prod_{k=2}^n P(w_k / w_{k-L} \dots w_{k-1})$$

This method of conditioning a state based on L recent states is called the Markov assumption of chain rule probability. Although it is an approximation, it is a necessary one for traditional language models since the words cannot be conditioned on a large sequence of words because of memory constraints.

Language models are generally used for varied tasks related to natural language processing, such as sentence completion by predicting the next words, machine translation, speech recognition, and others. In machine translation, the words from another language might be translated to English but may not be correct syntactically. For example, a sentence in the Hindi language has been machine translated to produce the English sentence "*beautiful very is the sky*". If one computes the probability of the machine-translated sequence ($P(\text{"beautiful very is the sky"})$), it would be very much less than that of the arranged counterpart, ($P(\text{"The sky is very beautiful"})$). Through language modeling, such comparisons of the probability of text sequences can be carried out.

Predicting the Next Word in a Sentence Through RNN Versus Traditional Methods

In traditional language models, the probability of a word appearing next is generally conditioned on a window of a specified number of previous words, as discussed earlier. To estimate probabilities, different n -grams counts are usually computed. From bi-gram and tri-gram counts, the conditional probabilities can be computed as follows:

$$P(w = w_2 / w = w_1) = \frac{\text{count}(w_1, w_2)}{\text{count}(w_1)}$$

$$P(w = w_3 / w = w_1, w = w_2) = \frac{\text{count}(w_1, w_2, w_3)}{\text{count}(w_1, w_2)}$$

In a similar manner, we can condition the word probabilities on longer sequences of words by keeping count of larger n -grams. Generally, when a match is not found on a higher n -gram—let's say four-gram—then a lower n -gram such as a three-gram is tried. This method is called back off and gives some performance gain over a fixed n -gram approach.

Since word prediction is conditioned on only a few previous words based on the chosen window size, this traditional method of computing probabilities through n -gram counts doesn't do as well as those models in which the whole sequence of words is taken into consideration for the next word prediction.

In RNNs, the output at each step is conditioned on all previous words, and hence RNNs do a better job than the n -gram models at language-model tasks. To understand this, let's look at the working principals of a generative recurrent neural network while considering a sequence $(x_1, x_2, x_3, \dots, x_n)$ of length n .

The RNN updates its hidden state h_t recursively as $h_t = f(h_{t-1}, x_t)$. The hidden state h_{t-1} has information accumulated for sequence of words $(x_1, x_2, x_3, \dots, x_{t-1})$, and when the new word in the sequence x_t arrives the updated sequence information $(x_1, x_2, x_3, \dots, x_t)$ is encoded in h_t through the recursive update.

Now, if we must predict the next word based on the word sequence seen so far, i.e., $(x_1, x_2, x_3, \dots, x_t)$, the conditional probability distribution one needs to look at is

$$P(x_{n+1} = o_i / x_1, x_2, x_3, \dots, x_t)$$

where o_i represents any generalized word in the vocabulary.

For neural networks this probability distribution is governed by the computed hidden state h_t based on the sequence seen so far, i.e., $x_1, x_2, x_3, \dots, x_t$, and the model parameter V , which converts the hidden states to probabilities corresponding to every word in the vocabulary.

So,

$$P(x_{n+1} = o_i / x_1 x_2 x_3 \dots x_t)$$

$$= P(x_{n+1} = o_i / h_t) \text{ or } P(x_{n+1} = o_i / x_t; h_{t-1})$$

The vector of probabilities for $P(x_{n+1} = o_i / h_t)$ corresponding to all indices i over the vocabulary is given by $\text{Softmax}(W_{ho}h_t)$.

Backpropagation Through Time (BPTT)

Backpropagation for recurrent neural networks is same as that for feed-forward neural networks, with the only difference being that the gradient is the sum of the gradient with respect to the log loss at each step.

First, the RNN is unfolded in time, and then the forward step is executed to get the internal activations and the final predictions for output. Based on the predicted output and the actual output labels, the loss and the corresponding error at each time step is computed. The error at each time step is backpropagated to update the weights. So, any weight update is proportional to the sum of the gradients' contribution from errors at all the T time steps.

Let's look at a sequence of length T and at the weight updates through BPTT. We take the number of memory states as n (i.e., $h_t \in \mathbb{R}^{n \times 1}$) and choose the input vector length as D (i.e., $x_t \in \mathbb{R}^{D \times 1}$). At each sequence step t we predict the next word from a vocabulary of V words through a SoftMax function.

The total cost function for a sequence of length T is given as

$$C = - \sum_{t=1}^T \sum_{j=1}^V y_t^{(j)} \log o_t^{(j)}$$

Let's compute the gradient of the cost function with respect to the weights connecting the hidden memory states to the output states layers—i.e., the weights belonging to the matrix W_{ho} . The weight w_{ij} denotes the weight connecting the hidden state i to the output unit j .

The gradient of the cost function C_t with respect to w_{ij} can be broken down by the chain rule of partial derivatives as the product of the partial derivative of the cost function with respect to the output of the j th unit (i.e., $\frac{\partial C_t}{\partial o_t^{(j)}}$), the partial derivative of the output of the j th unit with respect to the net input $s_t^{(j)}$ at the j th

unit (i.e., $\frac{\partial o_t^{(j)}}{\partial s_t^{(j)}}$), and finally the partial derivative of the net input to the j th unit with respect to the

concerned weight from the i th memory unit to the j th hidden layer (i.e., $\frac{\partial s_t^{(j)}}{\partial w_{ij}}$).

$$\frac{\partial C_t}{\partial w_{ij}} = \frac{\partial C_t}{\partial o_t^{(j)}} \frac{\partial o_t^{(j)}}{\partial s_t^{(j)}} \frac{\partial s_t^{(j)}}{\partial w_{ij}} \tag{4.2.1}$$

$$\frac{\partial s_t^{(j)}}{\partial w_{ij}} = h_t^{(i)} \tag{4.2.2}$$

Considering the SoftMax over vocabulary V and the actual output at time t as $y_t = [y_t^{(1)} y_t^{(2)} \dots y_t^{(V)}]^T \in \mathbb{R}^{V \times 1}$,

$$\frac{\partial C_t}{\partial o_t^{(j)}} = -\frac{y_t^{(j)}}{o_t^{(j)}} \quad (4.2.3)$$

$$\frac{\partial o_t^{(j)}}{\partial s_t^{(j)}} = o_t^{(j)}(1 - o_t^{(j)}) \quad (4.2.4)$$

Substituting the expressions for individual gradients from (4.2.2), (4.2.3), and (4.2.4) into (4.2.1), we get

$$\frac{\partial C_t}{\partial w_{ij}} = -\frac{y_t^{(j)}}{o_t^{(j)}} o_t^{(j)}(1 - o_t^{(j)}) = -y_t^{(j)}(1 - o_t^{(j)})h_t^{(i)} \quad (4.2.5)$$

To get the expression of the gradient of the total cost function C with respect to w_{ij} , one needs to sum up the gradients at each sequence step. Hence, the expression for the gradient $\frac{\partial C}{\partial w_{ij}}$ is as follows:

$$\frac{\partial C}{\partial w_{ij}} = \sum_{t=1}^T \frac{\partial C_t}{\partial w_{ij}} = \sum_{t=1}^T -y_t^{(j)}(1 - o_t^{(j)})h_t^{(i)} \quad (4.2.6)$$

So, we can see that determining the weights of the connections from the memory state to the output layers is pretty much the same as doing so for the fully connected layers of feed-forward neural networks, the only difference being that the effect of each sequential step is summed up to get the final gradient.

Now, let's look at the gradient of the cost function with respect to the weights connecting the memory states in one step to the memory states in the next step—i.e., the weights of the matrix W_{hh} . We take the generalized weight $u_{ki} \in W_{hh}$, where k and i are indexes of the memory units in consecutive memory units.

This will get a little more involved because of the recurrent nature of the memory units' connections. To appreciate this fact, let's look at the output of the memory unit indexed by i at step t —i.e., $h_t^{(i)}$:

$$h_t^{(i)} = g \left(\sum_{l=1}^N u_{li} h_{t-1}^{(l)} + \sum_{m=1}^D v_{mi} x_t^{(m)} + b_{hi} \right) \quad (4.2.7)$$

Now, let's look at the gradient of the cost function at step t with respect to the weight u_{ki} :

$$\frac{\partial C_t}{\partial u_{ki}} = \frac{\partial C_t}{\partial h_t^{(i)}} \frac{\partial h_t^{(i)}}{\partial u_{ki}} \quad (4.2.8)$$

We are only interested in expressing $h_t^{(i)}$ as a function of u_{ki} , and hence we rearrange (4.2.7) as follows:

$$\begin{aligned} h_t^{(i)} &= g \left(u_{ki} h_{t-1}^{(k)} + u_{ii} h_{t-1}^{(i)} + \sum_{\substack{l=1 \\ l \neq k, i}}^N u_{li} h_{t-1}^{(l)} + \sum_{m=1}^D v_{mi} x_t^{(m)} + b_{hi} \right) \\ &= g \left(u_{ki} h_{t-1}^{(k)} + u_{ii} h_{t-1}^{(i)} + c_t^{(i)} \right) \end{aligned} \quad (4.2.9)$$

where

$$c_t^{(i)} = \sum_{l=1}^N u_{li} h_{t-1}^{(l)} + \sum_{m=1}^D v_{mi} x_t^{(m)}$$

We have rearranged $h_t^{(i)}$ to be a function that contains the required weight u_{ki} and kept $h_{t-1}^{(i)}$ since it can be expressed through recurrence as $g(u_{ki} h_{t-2}^{(k)} + u_{ii} h_{t-2}^{(i)} + c_{t-1}^{(i)})$.

This nature of recurrence at every time step t would continue up to the first step, and hence one needs to consider the summation effect of all associated gradients from $t=t$ to $t=1$. If the gradient of $h_t^{(i)}$ with respect to the weight u_{ki} follows the recurrence, and if we take the derivative of $h_t^{(i)}$ as expressed in (4.2.9) with respect to u_{ki} , then the following will hold true:

$$\frac{\partial h_t^{(i)}}{\partial u_{ki}} = \sum_{t'=1}^t \frac{\partial h_{t'}^{(i)}}{\partial h_{t'}^{(i)}} \frac{\bar{\partial} h_{t'}^{(i)}}{\partial u_{ki}} \quad (4.2.10)$$

Please note the bar for the expression $\frac{\bar{\partial} h_{t'}^{(i)}}{\partial u_{ki}}$. It denotes the local gradient of $h_{t'}^{(i)}$ with respect to u_{ki} , holding $h_{t'-1}^{(i)}$ constant.

Replacing (4.2.9) with (4.2.8) we get

$$\frac{\partial C_t}{\partial u_{ki}} = \sum_{t'=1}^t \frac{\partial C_t}{\partial h_{t'}^{(i)}} \frac{\partial h_{t'}^{(i)}}{\partial h_{t'}^{(i)}} \frac{\bar{\partial} h_{t'}^{(i)}}{\partial u_{ki}} \quad (4.2.11)$$

The equation (4.2.11) gives us the generalized equation of the gradient of the cost function at time t . Hence, to get the total gradient we need to sum up the gradients with respect to the cost at each time step. Therefore, the total gradient can be represented by

$$\frac{\partial C}{\partial u_{ki}} = \sum_{t=1}^T \sum_{t'=1}^t \frac{\partial C_t}{\partial h_{t'}^{(i)}} \frac{\partial h_{t'}^{(i)}}{\partial h_{t'}^{(i)}} \frac{\bar{\partial} h_{t'}^{(i)}}{\partial u_{ki}} \quad (4.2.12)$$

The expression $\frac{\partial h_{t'}^{(i)}}{\partial h_{t'}^{(i)}}$ follows a product recurrence and hence can be formulated as

$$\frac{\partial h_{t'}^{(i)}}{\partial h_{t'}^{(i)}} = \prod_{g=t'+1}^t \frac{\partial h_g^{(i)}}{\partial h_{g-1}^{(i)}} \quad (4.2.13)$$

Combining (4.2.12) and (4.2.13), we get

$$\frac{\partial C}{\partial u_{ki}} = \sum_{t=1}^T \sum_{t'=1}^t \frac{\partial C_t}{\partial h_{t'}^{(i)}} \left(\prod_{g=t'+1}^t \frac{\partial h_g^{(i)}}{\partial h_{g-1}^{(i)}} \right) \frac{\bar{\partial} h_{t'}^{(i)}}{\partial u_{ki}} \quad (4.2.14)$$

The computation of the gradient of the cost function C for the weights of the matrix W_{xh} can be computed in a manner similar to that for the weights corresponding to the memory states.

Vanishing and Exploding Gradient Problem in RNN

The aim of recurrent neural networks (RNNs) is to learn long dependencies so that the interrelations between words that are far apart are captured. For example, the actual meaning that a sentence is trying to convey may be captured well by words that are not in close proximity to each other. Recurrent neural networks should be able to learn those dependencies. However, RNNs suffer from an inherent problem: they fail to capture long-distance dependencies between words. This is because the gradients in instances of long sequences have a high chance of either going to zero or going to infinity very quickly. When the gradients drop to zero very quickly, the model is unable to learn the associations or correlations between events that are temporally far apart. The equations derived for the gradient of the cost function with respect to the weights of the hidden memory layers will help us understand why this vanishing-gradient problem might take place.

The gradient of the cost function C_t at step t for a generalized weight $u_{ki} \in W_{hh}$ is given by

$$\frac{\partial C_t}{\partial u_{ki}} = \sum_{t'=1}^t \frac{\partial C_t}{\partial h_t^{(i)}} \frac{\partial h_t^{(i)}}{\partial h_{t'}^{(i)}} \frac{\partial h_{t'}^{(i)}}{\partial u_{ki}}$$

where the notations comply with their original interpretations as mentioned in the “Backpropagation Through Time (BPTT)” section.

The components summed to form $\frac{\partial C_t}{\partial u_{ki}}$ are called its temporal components. Each of those components measures how the weight u_{ki} at step t' influences the loss at step t . The component $\frac{\partial h_t^{(i)}}{\partial h_{t'}^{(i)}}$ backpropagates the error at step t back to step t' .

Also,

$$\frac{\partial h_t^{(i)}}{\partial h_{t'}^{(i)}} = \prod_{g=t'+1}^t \frac{\partial h_g^{(i)}}{\partial h_{g-1}^{(i)}}$$

Combining the preceding two equations, we get

$$\frac{\partial C_t}{\partial u_{ki}} = \sum_{t'=1}^t \frac{\partial C_t}{\partial h_t^{(i)}} \left(\prod_{g=t'+1}^t \frac{\partial h_g^{(i)}}{\partial h_{g-1}^{(i)}} \right) \frac{\partial h_{t'}^{(i)}}{\partial u_{ki}}$$

Let's take the net input at a memory unit i at time step g to be $z_g^{(i)}$. So, if we take the activation at the memory units to be sigmoids, then

$$h_g^{(i)} = \sigma(z_g^{(i)})$$

where σ is the sigmoid function.

Now,

$$\frac{\partial h_g^{(i)}}{\partial h_{g-1}^{(i)}} = \sigma'(z_g^{(i)}) \frac{\partial z_g^{(i)}}{\partial h_{g-1}^{(i)}} = \sigma'(z_g^{(i)}) u_{ii}$$

Where $\sigma'(z_g^{(i)})$ denotes the gradient of $\sigma(z_g^{(i)})$ with respect to $z_g^{(i)}$.

If we have a long sequence, i.e., $t = T$ and $t' = k$, then the following quantity would have many derivatives of the sigmoid function, as shown here:

$$\frac{\partial h_t^{(i)}}{\partial h_k^{(i)}} = \prod_{g=k+1}^T \frac{\partial h_g^{(i)}}{\partial h_{g-1}^{(i)}} = \frac{\partial h_{k+1}^{(i)}}{\partial h_k^{(i)}} \frac{\partial h_{k+2}^{(i)}}{\partial h_{k+1}^{(i)}} \dots \frac{\partial h_t^{(i)}}{\partial h_{t-1}^{(i)}} = \sigma'(z_{k+1}^{(i)}) u_{ii} \sigma'(z_{k+2}^{(i)}) u_{ii} \dots \sigma'(z_t^{(i)}) u_{ii}$$

Combining the gradient expressions in product-notation form, this important equation can be rewritten as follows:

$$\frac{\partial h_t^{(i)}}{\partial h_k^{(i)}} = (u_{ii})^{t-k} \prod_{g=k+1}^t \sigma'(z_g^{(i)}) \quad (1)$$

Sigmoid functions have good gradients only within a small range of values and saturate very quickly. Also, the gradients of sigmoid activation functions are less than 1. So, when the error from a long-distance step at $t = T$ passes to a step at $t = 1$ there would be $(T - 1)$ sigmoid activation function gradients the error must pass through, and the multiplicative effect of $(T - 1)$ gradients of values less than 1 may make the gradient component $\frac{\partial h_t^{(i)}}{\partial h_1^{(i)}}$ vanish exponentially fast. As discussed, $\frac{\partial h_t^{(i)}}{\partial h_1^{(i)}}$ backpropagates the error at step $T = t$ back to step $t = 1$ so that the long-distance correlation between the words at steps $t = 1$ and $t = T$ is learned. However, because of the vanishing-gradient problem, $\frac{\partial h_t^{(i)}}{\partial h_1^{(i)}}$ may not receive enough gradient and may be close to zero, and hence it won't be possible to learn the correlation or dependencies between the long-distance words in a sentence.

RNNs can suffer from exploding gradients too. We see in the expression for $\frac{\partial h_t^{(i)}}{\partial h_1^{(i)}}$ the weight u_{ii} has been repeatedly multiplied $(T - 1)$ times. If $u_{ii} > 1$, and for simplicity we assume $u_{ii} = 2$, then after 50 steps of backpropagation from the sequence step T to sequence step $(T - 50)$ the gradient would magnify approximately 2^{50} times and hence would drive the model training into instability.

Solution to Vanishing and Exploding Gradients Problem in RNNs

There are several methods adopted by the deep-learning community to combat the vanishing-gradient problem. In this section, we will discuss those methods before moving on to a variant of RNN called long short-term memory (LSTM) recurrent neural networks. LSTMs are much more robust regarding vanishing and exploding gradients.

Gradient Clipping

Exploding gradients can be tackled by a simple technique called gradient clipping. If the magnitude of the gradient vector exceeds a specified threshold, then the magnitude of the gradient vector is set to the threshold while keeping the direction of the gradient vector intact. So, while doing backpropagation on a neural network at time t , if the gradient of the cost function C with respect to the weight vector w exceeds a threshold k , then the gradient g used for backpropagation is updated as follows:

- **Step 1:** Update $g \leftarrow \nabla C(w = w^{(t)})$
- **Step 2:** If $\|g\| > k$ then update $g \leftarrow \frac{k}{\|g\|} g$

Smart Initialization of the Memory-to-Memory Weight Connection Matrix and ReLU units

Instead of randomly initializing the weights in the weight matrix W_{hh} , initializing it as an identity matrix helps prevent the vanishing-gradient problem. One of the main reasons for the vanishing-gradient problem is the gradient of the hidden unit i at time t with respect to the hidden unit i at time t' where $t' \ll t$ is given by

$$\frac{\partial h_t^{(i)}}{\partial h_{t'}^{(i)}} = \prod_{g=t'+1}^t \frac{\partial h_g^{(i)}}{\partial h_{g-1}^{(i)}}$$

In the case of the sigmoid activation function, each of the terms $\frac{\partial h_g^{(i)}}{\partial h_{g-1}^{(i)}}$ can be expanded as follows:

$$\frac{\partial h_g^{(i)}}{\partial h_{g-1}^{(i)}} = \sigma'(z_g^{(i)}) u_{ii}$$

where $\sigma(\cdot)$ denotes the sigmoid function and $z_g^{(i)}$ denotes the net input to hidden unit i at step t . The parameter u_{ii} is the weight connecting the i th hidden memory state at any sequence step $t-1$ to the i th hidden unit memory at sequence step t .

The greater the distance is between sequence steps t' and t , the more sigmoid derivatives the error would go through in passing from t to t' . Since the sigmoid activation function derivatives are always less than 1 and saturate quickly, the chance of the gradient going to zero in cases of long dependencies is high.

If, however, we choose ReLU units, then the sigmoid gradients would be replaced by ReLU gradients, which have a constant value of 1 for positive net input. This would reduce the vanishing-gradient problem since when the gradient is 1 the gradients would flow unattenuated. Also, when the weight matrix is chosen to be identity then the weight connection u_{ii} would be 1, and hence the quantity $\frac{\partial h_t^{(i)}}{\partial h_{t'}^{(i)}}$ would be 1

irrespective of the distance between sequence step t and sequence step t' . This means that the error that would be propagated from hidden memory state $h_t^{(i)}$ at time t to the hidden memory state $h_{t'}^{(i)}$ at any prior time step t' would be constant irrespective of the distance from step t to t' . This will enable the RNN to learn associated correlations or dependencies between the long-distance words in a sentence.

Long Short-Term Memory (LSTM)

Long short-term memory recurrent neural networks, popularly known as LSTMs, are special versions of RNNs that can learn distant dependencies between words in a sentence. Basic RNNs are incapable of learning such correlations between distant words, as discussed earlier. The architecture of long short-term memory (LSTM) recurrent neural networks is quite a bit different than that of traditional RNNs. Represented in Figure 4-12 is a high-level representation of an LSTM.

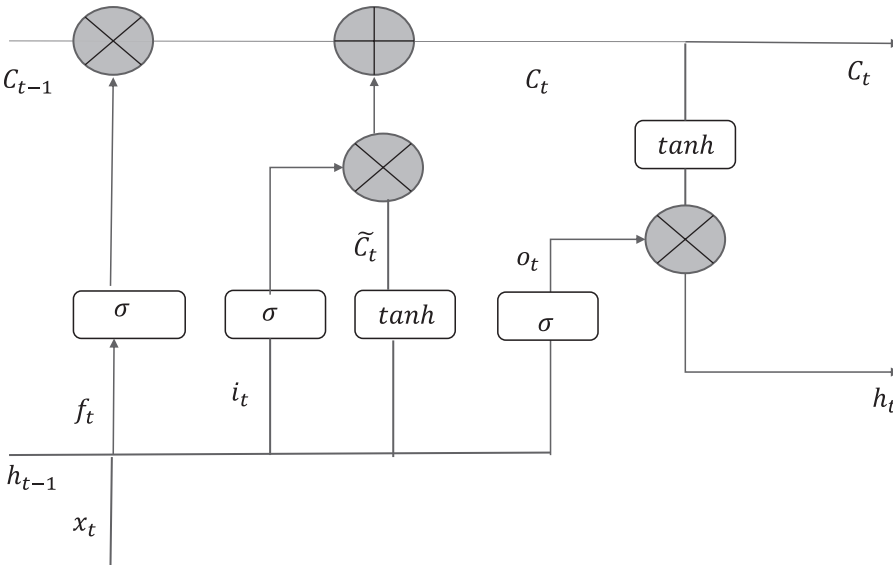

Figure 4-12. LSTM architecture

The basic building blocks of an LSTM and their functions are as follows:

- The new element in LSTMs is the introduction of the cell state C_t , which is regulated by three gates. The gates are composed of sigmoid functions so that they output values between 0 and 1.

At sequence step t the input x_t and the previous step's hidden states h_{t-1} decide what information to forget from cell state C_{t-1} through the forget-gate layer. The forget gate looks at x_t and h_{t-1} and assigns a number between 0 and 1 for each element in the cell state vector C_{t-1} . An output of 0 means totally forget the state while an output of 1 means keep the state completely. The forget gate output is computed as follows:

$$f_t = \sigma(W_f x_t + U_f h_{t-1})$$

- Next, the input gate decides which cell units should be updated with new information. For this, like the forget-gate output, a value between 0 to 1 is computed for each cell state component through the following logic:

$$i_t = \sigma(W_i x_t + U_i h_{t-1})$$

Then, a candidate set of new values is created for the cell state using x_t and h_{t-1} as input. The candidate cell state \tilde{C}_t is computed as follows:

$$\tilde{C}_t = \tanh(W_c x_t + U_c h_{t-1})$$

The new cell state C_t is updated as follows:

$$C_t = f_t * C_{t-1} + i_t * \tilde{C}_t$$

- The next job is to determine which cell states to output since the cell state contains a lot of information. For this, x_t and h_{t-1} are passed through an output gate, which outputs a value between 0 to 1 for each component in the cell state vector C_t . The output of this gate is computed as follows:

$$o_t = \sigma(W_o x_t + U_o h_{t-1})$$

- The updated hidden state h_t is computed from the cell state C_t by passing each of its elements through a *tanh* function and then doing an element-wise product with the output gate values:

$$h_t = o_t * \tanh(C_t)$$

Please note that the symbol * in the preceding equations denotes element-wise multiplication. This is done so that, based on the gate outputs, we can assign weights to each element of the vector it is operated on. Also, note that whatever gate output values are obtained they are multiplied as is. The gate outputs are not converted to discrete values of 0 and 1. Continuous values between 0 and 1 through sigmoid provide smooth gradients for backpropagation.

The forget gate plays a crucial role in the LSTM, when the forget gate units output zero then the recurrent gradients becomes zero and the corresponding old cell state units are discarded. This way, the LSTM throws away information that it thinks is not going to be useful in the future. Also, when the forget-gate units output 1, the error flows through the cell units unattenuated and the model can learn long-distance correlations between temporally distant words. We will discuss more about this in the next section.

Another important feature of the LSTM is the introduction of the output gates. The output-gate unit ensures that not all information the cell state C_t units have is exposed to the rest of the network, and hence only the relevant information is revealed in the form of h_t . This ensures that the rest of the network is not impacted by the unnecessary data while that data in the cell state is still held back in the cell state to help drive future decisions.

LSTM in Reducing Exploding- and Vanishing -Gradient Problems

LSTMs don't suffer much from vanishing- or exploding-gradient problems. The main reason for this is the introduction of the forget gate f_t and the way the current cell state is dependent on it through the following equation:

$$C_t = f_t * C_{t-1} + i_t * \tilde{C}_t$$

This equation can be broken down on a cell state unit-level that has a general index i as follows:

$$C_t^{(i)} = f_t^{(i)} C_{t-1}^{(i)} + i_t^{(i)} \tilde{C}_t^{(i)}$$

It is important to note here that $C_t^{(i)}$ is linearly dependent on $C_{t-1}^{(i)}$ and hence the activation function is the identity function with a gradient of 1.

The notorious component in recurrent neural network backpropagation that may lead to vanishing or exploding gradients is the component $\frac{\partial h_t^{(i)}}{\partial h_k^{(i)}}$ when $(t-k)$ is large. This component backpropagates the error at sequence step t to sequence step k so that the model learns long-distant dependencies or correlations.

The expression for $\frac{\partial h_t^{(i)}}{\partial h_k^{(i)}}$, as we have seen in the vanishing and exploding gradient section, is given by the following:

$$\frac{\partial h_t^{(i)}}{\partial h_k^{(i)}} = (u_{ii})^{t-k} \prod_{g=k+1}^t \sigma'(z_g^{(i)})$$

A vanishing-gradient condition will arise when the gradients and/or weights are less than 1 since the product of $(t-k)$ in them would force the overall product to near zero. Since sigmoid gradients and tanh gradients are most of the time less than 1 and saturate fast where they have near-zero gradients, this problem of vanishing gradients would be more severe with those. Similarly, exploding gradients can happen when the weight connection u_{ii} between the i th hidden to the i th hidden unit is greater than 1 since the product of $(t-k)$ in them would make the term $(u_{ii})^{t-k}$ exponentially large.

The equivalent of $\frac{\partial h_t^{(i)}}{\partial h_k^{(i)}}$ in LSTM is the component $\frac{\partial C_t^{(i)}}{\partial C_k^{(i)}}$, which can also be expressed in the product format as follows:

$$\frac{\partial C_t^{(i)}}{\partial C_k^{(i)}} = \prod_{g=t+1}^t \frac{\partial C_g^{(i)}}{\partial C_{g-1}^{(i)}} \tag{4.3.1}$$

On taking the partial derivative on both sides of the cell state update equation $C_t^{(i)} = f_t^{(i)} C_{t-1}^{(i)} + i_t^{(i)} \tilde{C}_t^{(i)}$, one gets the important expression

$$\frac{\partial C_t^{(i)}}{\partial C_{t-1}^{(i)}} = f_t^{(i)} \tag{4.3.2}$$

Combining (1) and (2), one gets

$$\frac{\partial C_t^{(i)}}{\partial C_k^{(i)}} = (f_t^{(i)})^{t-k} \tag{4.3.3}$$

The equation (4.3.3) says that if the forget-gate value is held near 1, LSTM will not suffer from vanishing- or exploding-gradient problems.

MNIST Digit Identification in TensorFlow Using Recurrent Neural Networks

We see an implementation of RNN in classifying the images in the MNIST dataset through LSTM. The images of MNIST dataset are 28×28 in dimension. Each image would be treated as having 28 sequence steps, and each sequence step would consist of a row in an image. There would not be outputs after each sequence step but rather only one output at the end of the 28 steps for each image. The output is one of the ten classes corresponding to the ten digits from 0 to 9. So, the output layer would be a SoftMax of ten classes. The hidden cell state of the final sequence step h_{28} would be fed through weights into the output layer. So, only the final sequence step would contribute to the cost function; there would be no cost function associated with the intermediate sequence steps. If you remember, backpropagation was with respect to the cost function C_t in each individual sequence step t when there was output involved at each sequence step, and finally the gradients with respect to each of those cost functions were summed together. Here, everything else remains the same and backpropagation would be done only with respect to the cost at sequence step 28, C_{28} . Also, as stated earlier, each row of an image would form data at a sequence step t and hence would be the input vector x_t . Finally, we would be processing images in a mini batch, and thus for each image in the batch a similar processing procedure would be followed, minimizing the average cost over the batch. One more important thing to note is that TensorFlow demands that there be separate tensors for each step within the mini-batch input tensor. The input tensor structure has been depicted in Figure 4-13 for ease of understanding.

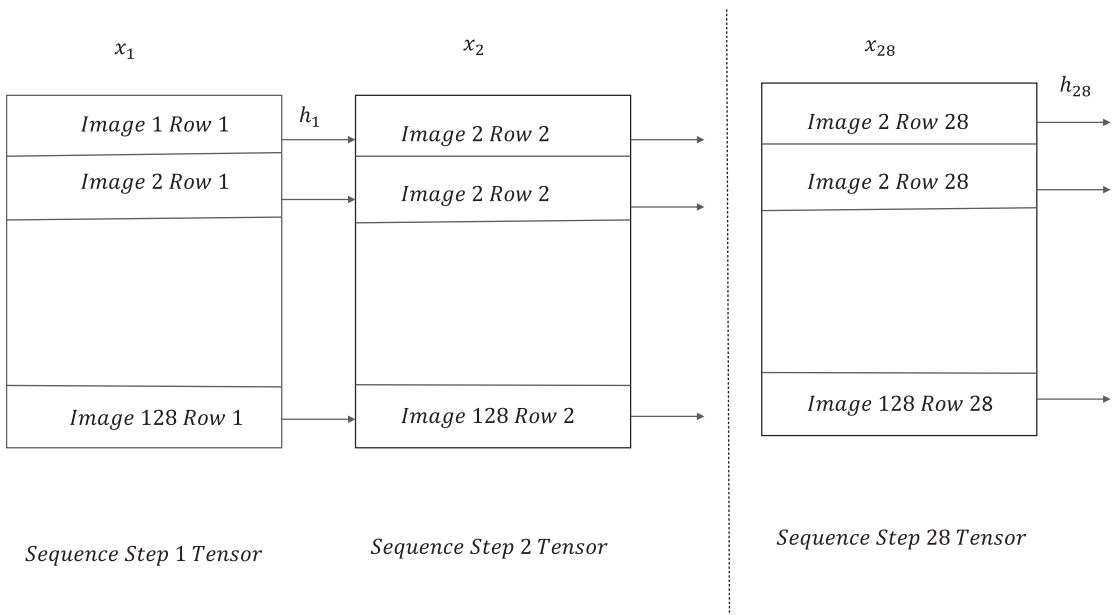

Figure 4-13. Input tensor shape for RNN LSTM network in TensorFlow

Now that we have some clarity about the problem and approach, we will proceed with the implementation in TensorFlow. The detailed code for training the model and validating it on the test dataset is illustrated in Listing 4-3.

Listing 4-3. TensorFlow Implementation of Recurrent Neural Network using LSTM for Classification

```
#Import the Required Libraries
import tensorflow as tf
from tensorflow.contrib import rnn
import numpy as np

# Import MNIST data
from tensorflow.examples.tutorials.mnist import input_data
mnist = input_data.read_data_sets("MNIST_data/", one_hot=True)

# Batch Learning Parameters
learning_rate = 0.001
training_iters = 100000
batch_size = 128
display_step = 50
num_train = mnist.train.num_examples
num_batches = (num_train//batch_size) + 1
epochs = 2

# RNN LSTM Network Parameters
n_input = 28 # MNIST data input (img shape: 28*28)
n_steps = 28 # timesteps
n_hidden = 128 # hidden layer num of features
n_classes = 10 # MNIST total classes (0-9 digits)

# Define the forward pass for the RNN
def RNN(x, weights, biases):

    # Unstack to get a list of n_stepstensors of shape (batch_size, n_input) as illustrated
    # in Figure 4-12
    x = tf.unstack(x, n_steps, 1)

    # Define a lstm cell
    lstm_cell = rnn.BasicLSTMCell(n_hidden, forget_bias=1.0)

    # Get lstm cell output
    outputs, states = rnn.static_rnn(lstm_cell, x, dtype=tf.float32)

    # Linear activation, using rnn inner loop last output
    return tf.matmul(outputs[-1], weights['out']) + biases['out']

# tf Graph input
x = tf.placeholder("float", [None, n_steps, n_input])
y = tf.placeholder("float", [None, n_classes])
```

```

# Define weights
weights = {
    'out': tf.Variable(tf.random_normal([n_hidden, n_classes]))
}
biases = {
    'out': tf.Variable(tf.random_normal([n_classes]))
}

pred = RNN(x, weights, biases)

# Define loss and optimizer
cost = tf.reduce_mean(tf.nn.softmax_cross_entropy_with_logits(logits=pred, labels=y))
optimizer = tf.train.AdamOptimizer(learning_rate=learning_rate).minimize(cost)

# Evaluate model
correct_pred = tf.equal(tf.argmax(pred,1), tf.argmax(y,1))
accuracy = tf.reduce_mean(tf.cast(correct_pred, tf.float32))

# Initializing the variables
init = tf.global_variables_initializer()

with tf.Session() as sess:
    sess.run(init)
    i = 0

    while i < epochs:
        for step in xrange(num_batches):
            batch_x, batch_y = mnist.train.next_batch(batch_size)
            batch_x = batch_x.reshape((batch_size, n_steps, n_input))
            # Run optimization op (backprop)
            sess.run(optimizer, feed_dict={x: batch_x, y: batch_y})
            if (step + 1) % display_step == 0:
                # Calculate batch accuracy
                acc = sess.run(accuracy, feed_dict={x: batch_x, y: batch_y})
                # Calculate batch loss
                loss = sess.run(cost, feed_dict={x: batch_x, y: batch_y})
                print "Epoch: " + str(i+1) + ", step:" + str(step+1) + ", Minibatch Loss= " + \
                    "{:.6f}".format(loss) + ", Training Accuracy= " + \
                    "{:.5f}".format(acc)

            i += 1
        print "Optimization Finished!"

# Calculate accuracy
test_len = 500
test_data = mnist.test.images[:test_len].reshape((-1, n_steps, n_input))
test_label = mnist.test.labels[:test_len]
print "Testing Accuracy:", \
    sess.run(accuracy, feed_dict={x: test_data, y: test_label})

```

```
xx--output--xx
```

```
Extracting MNIST_data/train-images-idx3-ubyte.gz
Extracting MNIST_data/train-labels-idx1-ubyte.gz
Extracting MNIST_data/t10k-images-idx3-ubyte.gz
Extracting MNIST_data/t10k-labels-idx1-ubyte.gz
Epoch: 1,step:50, Minibatch Loss= 0.822081, Training Accuracy= 0.69531
Epoch: 1,step:100, Minibatch Loss= 0.760435, Training Accuracy= 0.75781
Epoch: 1,step:150, Minibatch Loss= 0.322639, Training Accuracy= 0.89844
Epoch: 1,step:200, Minibatch Loss= 0.408063, Training Accuracy= 0.85156
Epoch: 1,step:250, Minibatch Loss= 0.212591, Training Accuracy= 0.93750
Epoch: 1,step:300, Minibatch Loss= 0.158679, Training Accuracy= 0.94531
Epoch: 1,step:350, Minibatch Loss= 0.205918, Training Accuracy= 0.92969
Epoch: 1,step:400, Minibatch Loss= 0.131134, Training Accuracy= 0.95312
Epoch: 2,step:50, Minibatch Loss= 0.161183, Training Accuracy= 0.94531
Epoch: 2,step:100, Minibatch Loss= 0.237268, Training Accuracy= 0.91406
Epoch: 2,step:150, Minibatch Loss= 0.130443, Training Accuracy= 0.94531
Epoch: 2,step:200, Minibatch Loss= 0.133215, Training Accuracy= 0.93750
Epoch: 2,step:250, Minibatch Loss= 0.179435, Training Accuracy= 0.95312
Epoch: 2,step:300, Minibatch Loss= 0.108101, Training Accuracy= 0.97656
Epoch: 2,step:350, Minibatch Loss= 0.099574, Training Accuracy= 0.97656
Epoch: 2,step:400, Minibatch Loss= 0.074769, Training Accuracy= 0.98438
Optimization Finished!
Testing Accuracy: 0.954102
```

As we can see from the Listing 4-3 output, just by running 2 epochs an accuracy of 95% is achieved on the Test Dataset.

Next-Word Prediction and Sentence Completion in TensorFlow Using Recurrent Neural Networks

We train a model on a small passage from *Alice in Wonderland* to predict the next word from the given vocabulary using LSTM. Sequences of three words have been taken as input, and the subsequent word has been taken as output for this problem. Also, a two-layered LSTM model has been chosen instead of one. The sets of inputs and outputs are chosen randomly from the corpus and fed as a mini batch of size 1. We see the model achieves good accuracy and is able to learn the passage well. Later, once the model is trained, we input a three-word sentence and let the model predict the next 28 words. Each time it predicts a new word it appends it to the updated sentence. For predicting the next word, the previous three words from the updated sentence are taken as input. The detailed implementation of the problem has been outlined in Listing 4-4.

Listing 4-4. Next-Word Prediction and Sentence Completion in TensorFlow Using Recurrent Neural Networks

```
# load the required libraries
import numpy as np
import tensorflow as tf
from tensorflow.contrib import rnn
import random
import collections
import time
```

```

# Parameters
learning_rate = 0.001
training_iters = 50000
display_step = 500
n_input = 3

# number of units in RNN cell
n_hidden = 512

# Function to read and process the input file
def read_data(fname):
    with open(fname) as f:
        data = f.readlines()
    data = [x.strip() for x in data]
    data = [data[i].lower().split() for i in range(len(data))]
    data = np.array(data)
    data = np.reshape(data, [-1, ])
    return data

# Function to build dictionary and reverse dictionary of words.
def build_dataset(train_data):
    count = collections.Counter(train_data).most_common()
    dictionary = dict()
    for word, _ in count:
        dictionary[word] = len(dictionary)
    reverse_dictionary = dict(zip(dictionary.values(), dictionary.keys()))
    return dictionary, reverse_dictionary

# Function to one-hot the input vectors
def input_one_hot(num):
    x = np.zeros(vocab_size)
    x[num] = 1
    return x.tolist()

# Read the input file and build the required dictionaries
train_file = 'alice in wonderland.txt'
train_data = read_data(train_file)
dictionary, reverse_dictionary = build_dataset(train_data)
vocab_size = len(dictionary)

# Place holder for Mini-batch input output
x = tf.placeholder("float", [None, n_input, vocab_size])
y = tf.placeholder("float", [None, vocab_size])

# RNN output node weights and biases
weights = {
    'out': tf.Variable(tf.random_normal([n_hidden, vocab_size]))
}
biases = {
    'out': tf.Variable(tf.random_normal([vocab_size]))
}

```

```

# Forward pass for the recurrent neural network
def RNN(x, weights, biases):

    x = tf.unstack(x, n_input, 1)

    # 2 layered LSTM Definition
    rnn_cell = rnn.MultiRNNCell([rnn.BasicLSTMCell(n_hidden),rnn.BasicLSTMCell(n_hidden)])

    # generate prediction
    outputs, states = rnn.static_rnn(rnn_cell, x, dtype=tf.float32)

    # there are n_input outputs but
    # we only want the last output
    return tf.matmul(outputs[-1], weights['out']) + biases['out']

pred = RNN(x, weights, biases)

# Loss and optimizer
cost = tf.reduce_mean(tf.nn.softmax_cross_entropy_with_logits(logits=pred, labels=y))
optimizer = tf.train.RMSPropOptimizer(learning_rate=learning_rate).minimize(cost)

# Model evaluation
correct_pred = tf.equal(tf.argmax(pred,1), tf.argmax(y,1))
accuracy = tf.reduce_mean(tf.cast(correct_pred, tf.float32))

# Initializing the variables
init = tf.global_variables_initializer()

# Launch the graph
with tf.Session() as session:
    session.run(init)
    step = 0
    offset = random.randint(0,n_input+1)
    end_offset = n_input + 1
    acc_total = 0
    loss_total = 0

    while step < training_iters:
        if offset > (len(train_data)-end_offset):
            offset = random.randint(0, n_input+1)

        symbols_in_keys = [ input_one_hot(dictionary[ str(train_data[i])]) for i in
            range(offset, offset+n_input) ]
        symbols_in_keys = np.reshape(np.array(symbols_in_keys), [-1, n_input,vocab_size])
        symbols_out_onehot = np.zeros([vocab_size], dtype=float)
        symbols_out_onehot[dictionary[str(train_data[offset+n_input])]] = 1.0
        symbols_out_onehot = np.reshape(symbols_out_onehot,[1,-1])

        _, acc, loss, onehot_pred = session.run([optimizer, accuracy, cost, pred], \
            feed_dict={x: symbols_in_keys, y: symbols_out_onehot})

```

```

loss_total += loss
acc_total += acc

if (step+1) % display_step == 0:
    print("Iter= " + str(step+1) + ", Average Loss= " + \
          "{:.6f}".format(loss_total/display_step) + ", Average Accuracy= " + \
          "{:.2f}%".format(100*acc_total/display_step))
    acc_total = 0
    loss_total = 0
    symbols_in = [train_data[i] for i in range(offset, offset + n_input)]
    symbols_out = train_data[offset + n_input]
    symbols_out_pred = reverse_dictionary[int(tf.argmax(onehot_pred, 1).eval())]
    print("%s - Actual word:[%s] vs Predicted word:[%s]" % (symbols_in,symbols_
    out,symbols_out_pred))
    step += 1
    offset += (n_input+1)
print("TrainingCompleted!")
# Feed a 3-word sentence and let the model predict the next 28 words
sentence = 'i only wish'
words = sentence.split(' ')
try:
    symbols_in_keys = [ input_one_hot(dictionary[ str(train_data[i])]) for i in
    range(offset, offset+n_input) ]
    for i in range(28):
        keys = np.reshape(np.array(symbols_in_keys), [-1, n_input,vocab_size])
        onehot_pred = session.run(pred, feed_dict={x: keys})
        onehot_pred_index = int(tf.argmax(onehot_pred, 1).eval())
        sentence = "%s %s" % (sentence,reverse_dictionary[onehot_pred_index])
        symbols_in_keys = symbols_in_keys[1:]
        symbols_in_keys.append(input_one_hot(onehot_pred_index))
    print "Complete sentence follows!"
    print(sentence)
except:
    print("Error while processing the sentence to be completed")

```

---output --

```

Iter= 30500, Average Loss= 0.073997, Average Accuracy= 99.40%
['only', 'you', 'can'] - Actual word:[find] vs Predicted word:[find]
Iter= 31000, Average Loss= 0.004558, Average Accuracy= 99.80%
['very', 'hopeful', 'tone'] - Actual word:[though] vs Predicted word:[though]
Iter= 31500, Average Loss= 0.083401, Average Accuracy= 99.20%
['tut', ',', 'tut'] - Actual word:[,] vs Predicted word:[,]
Iter= 32000, Average Loss= 0.116754, Average Accuracy= 99.00%
['when', 'they', 'met'] - Actual word:[in] vs Predicted word:[in]
Iter= 32500, Average Loss= 0.060253, Average Accuracy= 99.20%
['it', 'in', 'a'] - Actual word:[bit] vs Predicted word:[bit]
Iter= 33000, Average Loss= 0.081280, Average Accuracy= 99.00%
['perhaps', 'it', 'was'] - Actual word:[only] vs Predicted word:[only]
Iter= 33500, Average Loss= 0.043646, Average Accuracy= 99.40%
['you', 'forget', 'to'] - Actual word:[talk] vs Predicted word:[talk]

```

Iter= 34000, Average Loss= 0.088316, Average Accuracy= 98.80%
 [' ', 'and', 'they'] - Actual word:[walked] vs Predicted word:[walked]
 Iter= 34500, Average Loss= 0.154543, Average Accuracy= 97.60%
 ['a', 'little', 'startled'] - Actual word:[when] vs Predicted word:[when]
 Iter= 35000, Average Loss= 0.105387, Average Accuracy= 98.40%
 ['you', 'again', ','] - Actual word:[you] vs Predicted word:[you]
 Iter= 35500, Average Loss= 0.038441, Average Accuracy= 99.40%
 ['so', 'stingy', 'about'] - Actual word:[it] vs Predicted word:[it]
 Iter= 36000, Average Loss= 0.108765, Average Accuracy= 99.00%
 ['like', 'to', 'be'] - Actual word:[rude] vs Predicted word:[rude]
 Iter= 36500, Average Loss= 0.114396, Average Accuracy= 98.00%
 ['make', 'children', 'sweet-tempered'] - Actual word:[.] vs Predicted word:[.]
 Iter= 37000, Average Loss= 0.062745, Average Accuracy= 98.00%
 ['chin', 'upon', "alice's"] - Actual word:[shoulder] vs Predicted word:[shoulder]
 Iter= 37500, Average Loss= 0.050380, Average Accuracy= 99.20%
 ['sour', '\xe2\x80\x94', 'and'] - Actual word:[camomile] vs Predicted word:[camomile]
 Iter= 38000, Average Loss= 0.137896, Average Accuracy= 99.00%
 ['very', 'ugly', ';'] - Actual word:[and] vs Predicted word:[and]
 Iter= 38500, Average Loss= 0.101443, Average Accuracy= 98.20%
 ["", 'she', 'went'] - Actual word:[on] vs Predicted word:[on]
 Iter= 39000, Average Loss= 0.064076, Average Accuracy= 99.20%
 ['closer', 'to', "alice's"] - Actual word:[side] vs Predicted word:[side]
 Iter= 39500, Average Loss= 0.032137, Average Accuracy= 99.60%
 ['in', 'my', 'kitchen'] - Actual word:[at] vs Predicted word:[at]
 Iter= 40000, Average Loss= 0.110244, Average Accuracy= 98.60%
 [' ', 'tut', ','] - Actual word:[child] vs Predicted word:[child]
 Iter= 40500, Average Loss= 0.088653, Average Accuracy= 98.60%
 ["i'm", 'a', 'duchess'] - Actual word:[,] vs Predicted word:[,]
 Iter= 41000, Average Loss= 0.122520, Average Accuracy= 98.20%
 ["", "", 'perhaps'] - Actual word:[it] vs Predicted word:[it]
 Iter= 41500, Average Loss= 0.011063, Average Accuracy= 99.60%
 ['it', 'was', 'only'] - Actual word:[the] vs Predicted word:[the]
 Iter= 42000, Average Loss= 0.057289, Average Accuracy= 99.40%
 ['you', 'forget', 'to'] - Actual word:[talk] vs Predicted word:[talk]
 Iter= 42500, Average Loss= 0.089094, Average Accuracy= 98.60%
 ['and', 'they', 'walked'] - Actual word:[off] vs Predicted word:[off]
 Iter= 43000, Average Loss= 0.023430, Average Accuracy= 99.20%
 ['heard', 'her', 'voice'] - Actual word:[close] vs Predicted word:[close]
 Iter= 43500, Average Loss= 0.022014, Average Accuracy= 99.60%
 ['i', 'am', 'to'] - Actual word:[see] vs Predicted word:[see]
 Iter= 44000, Average Loss= 0.000067, Average Accuracy= 100.00%
 ["wouldn't", 'be', 'so'] - Actual word:[stingy] vs Predicted word:[stingy]
 Iter= 44500, Average Loss= 0.131948, Average Accuracy= 98.60%
 ['did', 'not', 'like'] - Actual word:[to] vs Predicted word:[to]
 Iter= 45000, Average Loss= 0.074768, Average Accuracy= 99.00%
 ['that', 'makes', 'them'] - Actual word:[bitter] vs Predicted word:[bitter]
 Iter= 45500, Average Loss= 0.001024, Average Accuracy= 100.00%
 [' ', 'because', 'she'] - Actual word:[was] vs Predicted word:[was]
 Iter= 46000, Average Loss= 0.085342, Average Accuracy= 98.40%
 ['new', 'kind', 'of'] - Actual word:[rule] vs Predicted word:[rule]
 Iter= 46500, Average Loss= 0.105341, Average Accuracy= 98.40%

```

['alice', 'did', 'not'] - Actual word:[much] vs Predicted word:[much]
Iter= 47000, Average Loss= 0.081714, Average Accuracy= 98.40%
['soup', 'does', 'very'] - Actual word:[well] vs Predicted word:[well]
Iter= 47500, Average Loss= 0.076034, Average Accuracy= 98.40%
['.', '"', "everything's"] - Actual word:[got] vs Predicted word:[got]
Iter= 48000, Average Loss= 0.099089, Average Accuracy= 98.20%
['.', '"', 'she'] - Actual word:[said] vs Predicted word:[said]
Iter= 48500, Average Loss= 0.082119, Average Accuracy= 98.60%
['.', '"', '"'] - Actual word:[perhaps] vs Predicted word:[perhaps]
Iter= 49000, Average Loss= 0.055227, Average Accuracy= 98.80%
['.', 'and', 'thought'] - Actual word:[to] vs Predicted word:[to]
Iter= 49500, Average Loss= 0.068357, Average Accuracy= 98.60%
['dear', ',', 'and'] - Actual word:[that] vs Predicted word:[that]
Iter= 50000, Average Loss= 0.043755, Average Accuracy= 99.40%
['affectionately', 'into', "alice's"] - Actual word:[,] vs Predicted word:[,]

```

Training Completed!

"Complete sentence follows!"

i only wish off together . alice was very glad to find her in such a pleasant temper , and thought to herself that perhaps it was only the pepper that

We can see from the output of Listing 4-4 that the model is able to predict the actual words while training quite nicely. In the sentence-completion task, although the prediction didn't start off well with the first two predictions, it did an excellent job for the rest of the 28 characters. The generated sentence is exceptionally rich in grammar and punctuation. The model accuracy can be increased by increasing the sequence length and also by introducing predictions after every word in the sequence. Also, the training corpus was small. Word-prediction and sentence-completion quality will be further enhanced if the model is trained on a larger corpus of data. Listing 4-5 shows the passage from *Alice in Wonderland* that was used to train the model.

Listing 4-5.

' You can't think how glad I am to see you again , you dear old thing ! ' said the Duchess , as she tucked her arm affectionately into Alice's , and they walked off together . Alice was very glad to find her in such a pleasant temper , and thought to herself that perhaps it was only the pepper that had made her so savage when they met in the kitchen . ' When I'm a Duchess , ' she said to herself , (not in a very hopeful tone though) , ' I won't have any pepper in my kitchen at all . Soup does very well without - Maybe it's always pepper that makes people hot-tempered , ' she went on , very much pleased at having found out a new kind of rule , ' and vinegar that makes them sour - and camomile that makes them bitter - and - and barley-sugar and such things that make children sweet-tempered . I only wish people knew that : then they wouldn't be so stingy about it , you know - 'She had quite forgotten the Duchess by this time , and was a little startled when she heard her voice close to her ear . ' You're thinking about something , my dear , and that makes you forget to talk . I can't tell you just now what the moral of that is , but I shall remember it in a bit . ' ' Perhaps it hasn't one , ' Alice ventured to remark . ' Tut , tut , child ! ' said the Duchess . ' Everything's got a moral , if only you can find it . ' And she squeezed herself up closer to Alice's side as she spoke . Alice did not much like keeping so close to her : first , because the Duchess was very ugly ; and secondly , because she was exactly the right height to rest her chin upon Alice's shoulder , and it was an uncomfortably sharp chin . However , she did not like to be rude , so she bore it as well as she could .

Gated Recurrent Unit (GRU)

Much like LSTM, the gates recurrent units, popularly known as GRU, have gating units that control the flow of information inside. However, unlike LSTM, they don't have separate memory cells. The hidden memory state h_t at any time step t is a linear interpolation between previous hidden memory states h_{t-1} and candidate new hidden state \tilde{h}_t . The architectural diagram of a GRU is presented in Figure 4-14.

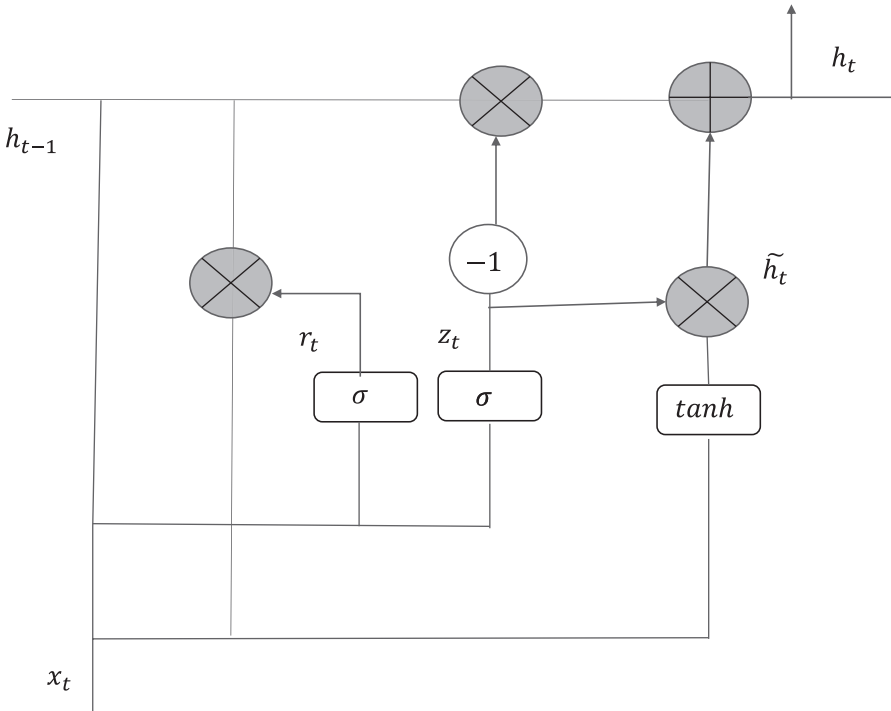

Figure 4-14. GRU architecture

The following are the high-level details as to how the GRU works:

- Based on the hidden memory state h_{t-1} and current input x_t , the reset gate r_t and the update gate z_t are computed as follows:

$$r_t = \sigma(W_r h_{t-1} + U_r x_t)$$

$$z_t = \sigma(W_z h_{t-1} + U_z x_t)$$

The reset gate determines how important h_{t-1} is in determining the candidate new hidden state. The update gate determines how much the new candidate state should influence the new hidden state.

- The candidate new hidden state \tilde{h}_t is computed as follows:

$$\tilde{h}_t = \tanh(r_t * U h_{t-1} + W x_t) \quad (4.4.1)$$

- Based on the candidate state and the previous hidden state, the new hidden memory state is updated as follows:

$$h_t = (1 - z_t) * h_{t-1} + z_t * \tilde{h}_t \quad (4.4.2)$$

The key point to stress in a GRU is the role of the gating functions, as discussed here:

- When the reset gate output units from r_t are close to zero, the previous hidden states for those units are ignored in the computation of the candidate new hidden state, as is evident from the equations in (4.4.1). This allows the model to drop information that would not be useful in the future.
- When the update gate output units from z_t are close to zero, then the previous step states for those units are copied over to the current step. As we have seen before, the notorious component in recurrent neural network backpropagation that may lead to vanishing or exploding gradients is the component $\frac{\partial h_t^{(i)}}{\partial h_k^{(i)}}$, which backpropagates the error at sequence step t to sequence step k so that the model learns long-distance dependencies or correlations. The expression for $\frac{\partial h_t^{(i)}}{\partial h_k^{(i)}}$, as we saw in the vanishing and exploding gradients section, is given by

$$\frac{\partial h_t^{(i)}}{\partial h_k^{(i)}} = (u_{ii})^{t-k} \prod_{g=k+1}^t \sigma'(z_g^{(i)})$$

When $(t - k)$ is large, a vanishing-gradient condition will arise when the gradients of the activations in the hidden state units and/or the weights are less than 1 since the product of $(t - k)$ in them would force the overall product to near zero. Sigmoid and tanh gradients are often less than 1 and saturate fast where they have near-zero gradients, thus making the problem of vanishing gradient more severe. Similarly, exploding gradients can happen when the weight connection u_{ii} between the i th hidden to the i th hidden unit is greater than 1 since the product of $(t - k)$ in them would make the term $(u_{ii})^{t-k}$ exponentially large for large values of $(t - k)$.

- Now, coming back to the GRU, when the update-gate output units in z_t are close to 0, then from the equation (4.4.2),

$$h_t^{(i)} \approx h_{t-1}^{(i)} \quad \forall i \in K \quad (4.4.3)$$

where K is the set of all hidden units for which $z_t^{(i)} \approx 0$.

On taking the partial derivative of $h_t^{(i)}$ with respect to $h_{t-1}^{(i)}$ in (4.4.3) we get the following:

$$\frac{\partial h_t^{(i)}}{\partial h_{t-1}^{(i)}} \approx 1$$

This will ensure that the notorious term $\frac{\partial h_t^{(i)}}{\partial h_k^{(i)}}$ is also close to 1 since it can be expressed as

$$\begin{aligned} \frac{\partial h_t^{(i)}}{\partial h_k^{(i)}} &= \prod_{g=t+1}^t \frac{\partial h_g^{(i)}}{\partial h_{g-1}^{(i)}} \\ &= 1.1.1.\dots 1(t-k) \text{ times} = 1 \end{aligned}$$

This allows the hidden states to be copied over many sequence steps without alteration, and hence the chances of a vanishing gradient diminish and the model is able to learn temporally long-distance association or correlation between words.

Bidirectional RNN

In a standard recurrent neural network we make predictions that take the past sequence states into account. For example, for predicting the next word in a sequence we take the words that appear before it into consideration. However, for certain tasks in natural language processing, such as parts of speech, tagging both past words and future words with respect to a given word is crucial in determining the given word's part of speech tag. Also, for parts of speech-tagging applications, the whole sentence would be available for tagging, and hence for each given word—barring the ones at the start and end of a sentence—its past and future words would be present to make use of.

Bidirectional RNNs are a special type of RNN that makes use of both the past and future states to predict the output label at the current state. A bidirectional RNN combines two RNNs, one of which runs forward from left to right and the other of which runs backward from right to left. A high-level architecture diagram of a bidirectional RNN is depicted in Figure 4-15.

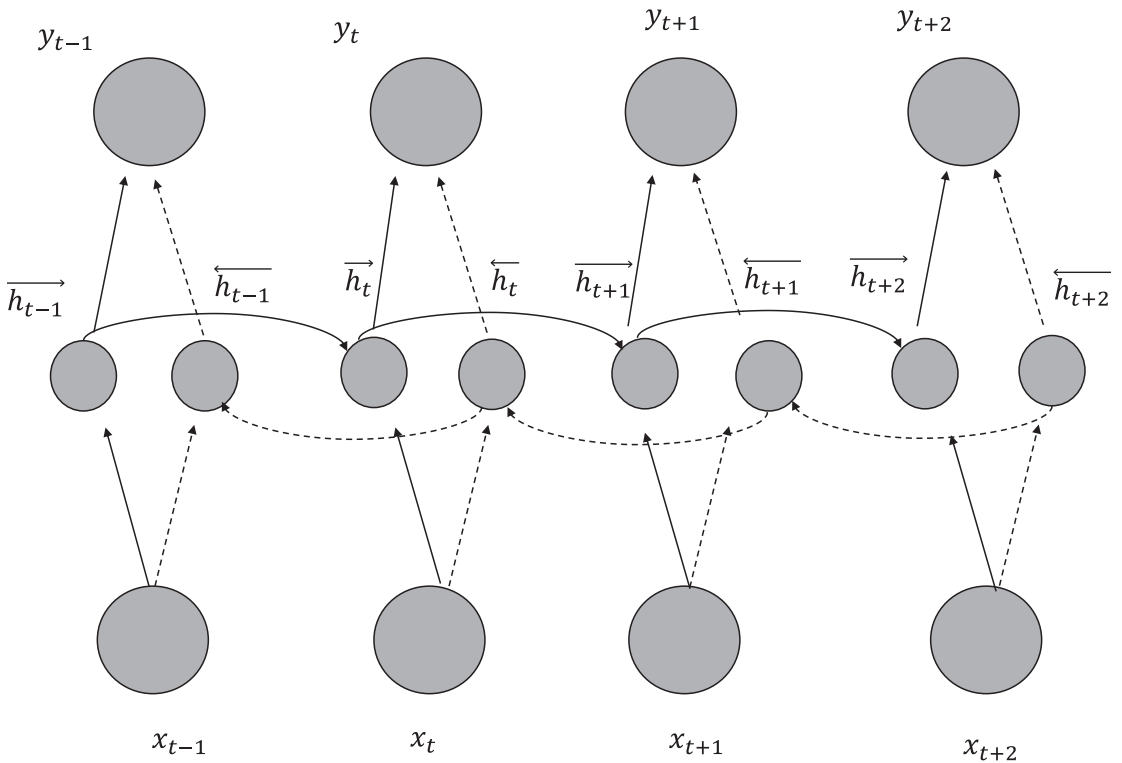

Figure 4-15. Bidirectional RNN architectural diagram

For a bidirectional RNN there are two hidden memory states for any sequence step t . The hidden memory states corresponding to the forward flow of information, as in standard RNN, can be represented as \overleftarrow{h}_t , and the ones corresponding to the backward flow of information can be denoted by \overrightarrow{h}_t . The output at any sequence step t depends on both the memory states \overleftarrow{h}_t and \overrightarrow{h}_t . The following are the governing equations for a bidirectional RNN.

$$\overleftarrow{h}_t = f(\overleftarrow{W}_{xh}x_t + \overleftarrow{W}_{hh}\overleftarrow{h}_{t-1} + \overleftarrow{b})$$

$$\overrightarrow{h}_t = f(\overrightarrow{W}_{xh}x_t + \overrightarrow{W}_{hh}\overrightarrow{h}_{t-1} + \overrightarrow{b})$$

$$y_t = g(U[\overleftarrow{h}_t; \overrightarrow{h}_t] + c)$$

The expression $[\overleftarrow{h}_t; \overrightarrow{h}_t]$ represents the combined memory state vector at time t . It can be obtained by concatenating the elements of the two vectors \overleftarrow{h}_t and \overrightarrow{h}_t .

\overleftarrow{W}_{hh} and \overrightarrow{W}_{hh} are the hidden state connection weights for the forward pass and the backward pass respectively. Similarly, \overleftarrow{W}_{xi} and \overrightarrow{W}_{xi} are the inputs to the hidden state weights for the forward and backward passes. The biases at the hidden memory state activations for forward and backward passes are given by \overrightarrow{b} and \overleftarrow{b} respectively. The term U represents the weight matrix from the combined hidden state to the output state, while c represents the bias at the output.

The function f is generally the non-linear activation function chosen at the hidden memory states. Chosen activation functions for f are generally sigmoid and tanh. However, ReLU activations are also being used now because they reduce the vanishing- and exploding-gradient problems. The function g would depend on the classification problem at hand. In cases of multiple classes, a SoftMax would be used, whereas for a two-class problem either a sigmoid or a two-class SoftMax could be used.

Summary

After this chapter, the reader is expected to have gained significant insights into the working principles of recurrent neural networks and their variants. Also, the reader should be able to implement RNN networks using TensorFlow with relative ease. Vanishing- and exploding-gradient problems with RNNs pose a key challenge in training them effectively, and thus many powerful versions of RNNs have evolved that take care of the problem. LSTM, being a powerful RNN architecture, is widely used in the community and has almost replaced the basic RNN. The reader is expected to know the uses and advantages of these advanced techniques, such as LSTM, GRU, and so forth, so that they can be accordingly implemented based on the problem. Pre-trained Word2Vec and GloVe word-vector embeddings are used by several RNN, LSTM, and other networks so that the input word to the model at each sequence step can be represented by its pre-trained Word2Vec or GloVe vector instead of learning these word-vector embeddings within the recurrent neural network itself.

In the next chapter, we will take up restricted Boltzmann machines (RBMs), which are energy-based neural networks, and various auto-encoders as part of unsupervised deep learning. Also, we will discuss deep-belief networks, which can be formed by stacking several restricted Boltzmann machines and training such networks in a greedy manner, and collaborative filtering through RBMs. I look forward to your participation in the next chapter.

CHAPTER 5



Unsupervised Learning with Restricted Boltzmann Machines and Auto-encoders

Unsupervised learning is a branch of machine learning that tries to find hidden structures within unlabeled data and derive insights from it. Clustering, data dimensionality-reduction techniques, noise reduction, segmentation, anomaly detection, fraud detection, and other rich methods rely on unsupervised learning to drive analytics. Today, with so much data around us, it is impossible to label all data for supervised learning. This makes unsupervised learning all the more important. Restricted Boltzmann machines and auto-encoders are unsupervised methods that are based on artificial neural networks. They have a wide range of uses in data compression and dimensionality reduction, noise reduction from data, anomaly detection, generative modeling, collaborative filtering, and initialization of deep neural networks, among other things. We will go through these topics in detail and then touch upon a couple of unsupervised pre-processing techniques for images, namely PCA (principal component analysis) whitening and ZCA (Mahalanobis) whitening. Also, since restricted Boltzmann machines use sampling techniques during training, I have briefly touched upon Bayesian inference and Markov Chain Monte Carlo sampling for reader's benefit.

Boltzmann Distribution

Restricted Boltzmann machines are energy models based on the Boltzmann Distribution Law of classical physics, where the state of particles of any system is represented by their generalized coordinates and velocities. These generalized coordinates and velocities form the phase space of the particles, and the particles can be in any location in the phase space with specific energy and probability. Let's consider a classical system that contains N gas molecules and let the generalized position and velocity of any particle be represented by $r \in \mathbb{R}^{3 \times 1}$ and $v \in \mathbb{R}^{3 \times 1}$ respectively. The location of the particle in the phase space can be represented by (r, v) . Every such possible value of (r, v) that the particle can take is called a *configuration* of the particle. Further, all the N particles are identical in the sense that they are equally likely to take up any state. Given such a system at thermodynamic temperature T , the probability of any such configuration is given as follows:

$$P(r, v) \propto e^{-\frac{E(r, v)}{kT}}$$

$E(r, v)$ is the energy of any particle at configuration (r, v) , and K is the Boltzmann Constant. Hence, we see that the probability of any configuration in the phase space is proportional to the exponential of the negative of the energy divided by the product of the Boltzmann Constant and the thermodynamic temperature. To convert the relationship into an equality, the probability needs to be normalized by the sum of the probabilities of all the possible configurations. If there are M possible phase-space configurations for the particles, then the probability of any generalized configuration (r, v) can be expressed as

$$P(r, v) = \frac{e^{-\frac{E(r, v)}{KT}}}{Z}$$

where Z is the partition function given by

$$Z = \sum_{i=1}^M e^{-\frac{E((r, v)_i)}{KT}}$$

There can be several values of r and v separately. However, M denotes all the unique combinations of r and v possible, which have been denoted by $(r, v)_i$ in the preceding equation. If r can take up n distinct coordinate values whereas v can take up m distinct velocity values, then the total number of possible configurations $M = n \times m$. In such cases, the partition function can also be expressed as follows:

$$Z = \sum_{j=1}^m \sum_{i=1}^n e^{-\frac{E(r_i, v_j)}{KT}}$$

The thing to note here is that the probability of any configuration is higher when its associated energy is low. For the gas molecules, it's intuitive as well given that high-energy states are always associated with unstable equilibrium and hence are less likely to retain the high-energy configuration for long. The particles in the high-energy configuration will always be in a pursuit to occupy much more stable low-energy states.

If we consider two configurations $s_1 = (r_1, v_1)$ and $s_2 = (r_2, v_2)$, and if the number of gas molecules in these two states are N_1 and N_2 respectively, then the probability ratio of the two states is a function of the energy difference between the two states:

$$\frac{N_1}{N_2} = \frac{P(r_1, v_1)}{P(r_2, v_2)} = e^{-\frac{E(r_1, v_1) - E(r_2, v_2)}{KT}}$$

We will digress a little now and briefly discuss Bayesian inference and Markov Chain Monte Carlo (MCMC) methods since restricted Boltzmann machines use sampling through MCMC techniques, especially Gibbs sampling, and some knowledge of these would go a long way toward helping the readers appreciate the working principles of restricted Boltzmann machines.

Bayesian Inference: Likelihood, Priors, and Posterior Probability Distribution

As discussed in Chapter 1, whenever we get data we build a model by defining a likelihood function over the data conditioned on the model parameters and then try to maximize that likelihood function. Likelihood is nothing but the probability of the seen or observed data given the model parameters:

$$\text{Likelihood} = P(\text{Data} / \text{Model})$$

To get the model defined by its parameters we maximize the likelihood of the seen data:

$$\text{Model} = \underbrace{\text{Arg max}}_{\text{Model}} P(\text{Data} / \text{Model})$$

Since we are only trying to fit a model based on the observed data, there is a high chance of overfitting and not generalizing to new data if we go for simple likelihood maximization.

If the data size is huge the seen data is likely to represent the population well and so maximizing the likelihood may suffice. On the other hand, if the seen data is small, there is a high chance that it might not represent the overall population well, and thus the model based on likelihood would not generalize well to new data. In that case, having a certain prior belief over the model and constraining the likelihood by that prior belief would lead to better results. Let's say that the prior belief is in the form of our knowing the uncertainty over the model parameters in the form of a probability distribution; i.e., $P(\text{Model})$ is known. We can in that case update our likelihood by the prior information to get a distribution over the model given the data. As per Bayes' Theorem of Conditional Probability,

$$P(\text{Model} / \text{Data}) = \frac{P(\text{Data} / \text{Model})P(\text{Model})}{P(\text{Data})}$$

$P(\text{Model}/\text{Data})$ is called the *posterior distribution* and is generally more informative since it combines one's prior knowledge about the data or model. Since this probability of data is independent of the model, the posterior is directly proportional to the product of the likelihood and the prior:

$$P(\text{Model} / \text{Data}) \propto P(\text{Data} / \text{Model})P(\text{Model})$$

One can build a model by maximizing the posterior probability distribution instead of the likelihood. This method of obtaining the model is called Maximize a Posterior, or MAP. Both likelihood and MAP are point estimates for the models and thus don't cover the whole uncertainty space. Taking the model that maximizes the posterior means taking the mode of the probability distribution of the model. Point estimates given by the maximum likelihood function don't correspond to any mode, since likelihood is not a probability-distribution function. If the probability distribution turns out to be multi-modal, these point estimates are going to perform even more poorly.

A better approach is to take the average of the model over the whole uncertainty space; i.e., to take the mean of the model based on the posterior distribution, as follows:

$$\text{Model} = E[\text{Model} / \text{Data}] = \int_{\text{Model}} \text{Model} P(\text{Model} / \text{Data}) d(\text{Model})$$

To motivate the ideas of likelihood and posterior and how they can be used to derive model parameters, let's get back to the coin problem again.

Suppose we toss a coin six times, out of which heads appears five times. If one is supposed to estimate the probability of heads, what would the estimate be?

Here, the model for us is to estimate the probability of heads θ in a throw of a coin. Each toss of a coin can be treated as an independent Bernoulli trial with the probability of heads being θ . The likelihood of the data, given the model, is given by

$$P(Data / \theta) = P(x_1, x_2, x_3, x_4, x_5, x_6 / \theta)$$

where $x_i \forall i \in \{1, 2, 3, 4, 5, 6\}$ denotes the event of either heads (H) or tails (T).

Since the throws of coins are independent, the likelihood can be factorized as follows:

$$P(Data / \theta) = P(x_1, x_2, x_3, x_4, x_5, x_6 / \theta) = \prod_{i=1}^6 P(x_i / \theta) \tag{5.1.1}$$

Each throw of dice follows the Bernoulli distribution, hence the probability of heads is θ and the probability of tails is $(1 - \theta)$, and in general its probability mass function is given by

$$P(x = j / \theta) = \theta^j (1 - \theta)^{(1-j)} \forall j \in \{0, 1\} \tag{5.1.2}$$

where $j=1$ denotes heads and $j=0$ denotes tails.

Since there are 5 heads and 1 tails combining (1) and (2), the likelihood L as a function of θ can be expressed as follows:

$$L(\theta) = \theta^5 (1 - \theta) \tag{5.1.3}$$

Maximum likelihood methods treat the $\hat{\theta}$ that minimizes $L(\theta)$ as the model parameter. Hence,

$$\hat{\theta} = \underbrace{Arg \max}_{\theta} L(\theta)$$

If we take the derivative of the computed likelihood in (5.1.3) and set it to zero, we will arrive at the likelihood estimate for θ :

$$\frac{dL(\theta)}{d\theta} = 5\theta^4 - 6\theta^5 = 0 \Rightarrow \theta = \frac{5}{6}$$

In general, if someone asks us our estimate of θ without our doing a similar maximization of likelihood, we at once answer the probability to be $\frac{5}{6}$ by the basic definition of probability that we learned in high school; i.e.,

$$P(event) = \frac{\text{no of events}}{\text{total number of events in the whole population}}$$

In a way, our head is thinking about likelihood and relying on the data seen thus far.

Now, let's suppose had we not seen the data and someone asked us to determine the probability of heads; what would have been a logical estimate?

Well, it depends on any prior belief that we hold about the coin that the probabilities would differ. If we assumed a fair coin, which in general is the most obvious assumption to make given that we have no information about the coin, $\theta = \frac{1}{2}$ would have been a good estimate. However, when we are assuming instead of doing a point estimate of prior for θ , it's better to have a probability distribution over θ with the probability maximum at $\theta = \frac{1}{2}$. The prior probability distribution is a distribution over the model parameter θ .

A Beta distribution with parameters $\alpha = 2$, $\beta = 2$ would be a good prior distribution in this case since it has a maximum probability at $\theta = \frac{1}{2}$ and is symmetrical around it.

$$P(\theta) = \text{Beta}(\alpha = 2, \beta = 2) = \frac{\theta^{\alpha-1}(1-\theta)^{\beta-1}}{B(\alpha, \beta)} = \frac{\theta(1-\theta)}{B(\alpha, \beta)}$$

For fixed values of α and β , $B(\alpha, \beta)$ is constant and is the normalizing or partition function to this probability distribution. It can be computed as follows:

$$B(\alpha, \beta) = \frac{\tau(\alpha)\tau(\beta)}{\tau(\alpha + \beta)} = \frac{\tau(2)\tau(2)}{\tau(4)} = \frac{1!1!}{3!} = \frac{1}{6}$$

Even if one doesn't remember the formula, it can be found out by just integrating $\theta(1-\theta)$ and taking the reciprocal of the same as the normalizing constant since the integral of the probability distribution should be 1.

$$P(\theta) = \frac{\theta(1-\theta)}{6} \quad (5.1.4)$$

If we combine the likelihood and the prior, we get the posterior probability distribution as follows:

$$P(\theta/D) \propto \theta^5(1-\theta) \frac{\theta(1-\theta)}{6} = \frac{\theta^6(1-\theta)^2}{6}$$

The proportional sign comes since we have ignored the probability of data. In fact, we can take the 6 out as well and express the posterior as follows:

$$P(\theta/D) \propto \theta^6(1-\theta)^2$$

Now, $0 \leq \theta \leq 1$ since θ is a probability. Integrating $\theta^6(1-\theta)^2$ in the range of 0 to 1 and taking the reciprocal would give us the normalizing factor of the posterior, which comes out to be 252. Hence, the posterior can be expressed as follows:

$$P(\theta/D) = \frac{\theta^6(1-\theta)^2}{252} \quad (5.1.5)$$

Now that we have the posterior, there are two ways we can estimate θ . We can maximize the posterior and get a MAP estimate of θ as follows:

$$\theta_{MAP} = \underset{\theta}{\text{Arg max}} P(\theta / D)$$

$$\frac{dP(\theta / D)}{d\theta} = 0 \Rightarrow \theta = \frac{3}{4}$$

We see the MAP estimate of $\frac{3}{4}$ is more conservative than the likelihood estimate of $\frac{5}{6}$ since it takes the prior into consideration and doesn't blindly believe the data.

Now, let's look at the second approach, the pure Bayesian approach, and take the mean of the posterior distribution to average over all the uncertainties for θ :

$$\begin{aligned} E[\theta / D] &= \int_{\theta=0}^1 \theta P(\theta / D) d\theta \\ &= \int_{\theta=0}^1 \frac{\theta^7 (1-\theta)^2}{252} d\theta \\ &= 0.7 \end{aligned}$$

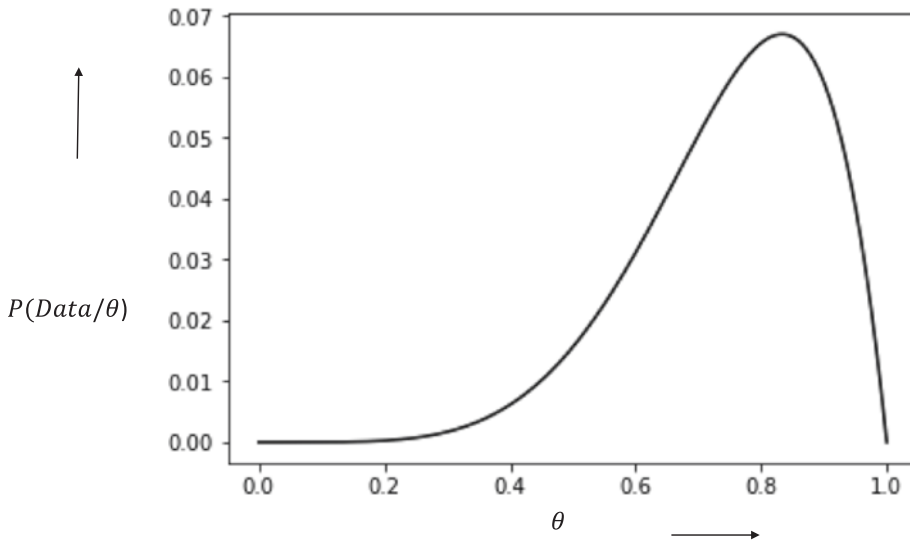

Figure 5-1a. Likelihood function plot

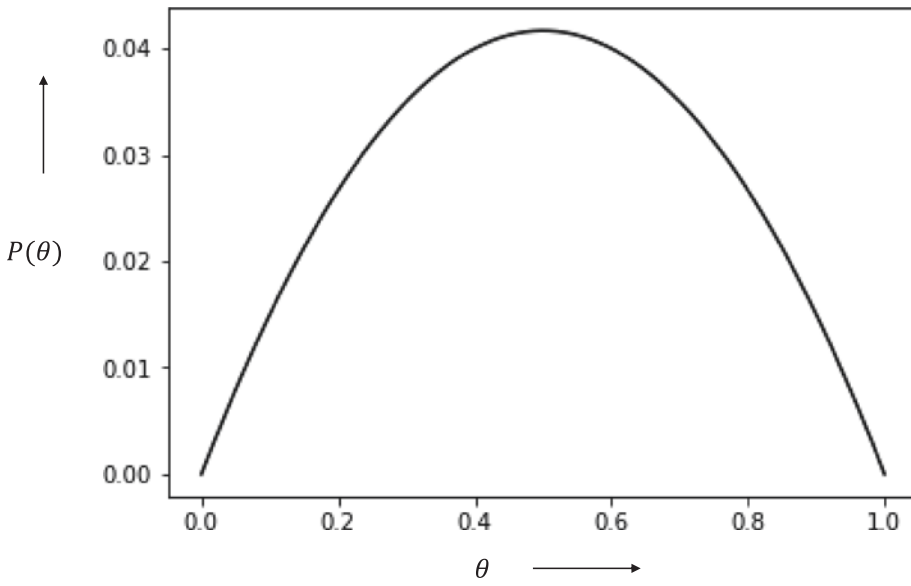

Figure 5-1b. Prior probability distribution

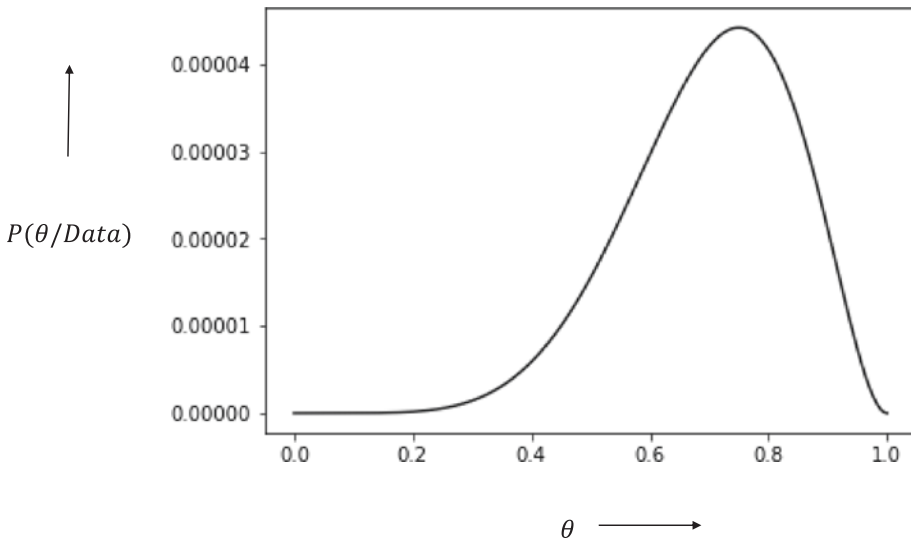

Figure 5-1c. Posterior probability distribution

Plotted in Figure 5-1a through Figure 5-1c are the likelihood function and the prior and posterior probability distributions for the coin problem. One thing to note is the fact that the likelihood function is not a probability density function or a probability mass function, whereas the prior and posteriors are probability mass or density functions.

For complicated distributions, the posterior probability distribution can turn out to be very complex with several parameters and is unlikely to represent known probability distribution forms such as normal, gamma, and so on. Thus, it may become seemingly impossible to compute the integral over the whole uncertainty space of the model in order to compute the mean of the posterior.

Markov Chain Monte Carlo methods of sampling can be used in such cases to sample model parameters, and then their mean is a fair estimate of the mean of the posterior distribution. If we sample n sets of model parameters M_i then

$$E[Model / Data] \approx \sum_{i=1}^n M_i$$

Generally, the mean of the distribution is taken since it minimizes the squared error that is of all c .

$E[(y - c)^2]$ is minimized when $c = E[y]$. Given that we are trying to represent the probability of the distribution by a single representative such that the squared error over the probability distribution is minimized, mean is the best candidate.

However, one can take the median of the distribution if the distribution is skewed and/or there is more noise in the data in the form of potential outliers. This estimated median can be based on the samples drawn from the posterior.

Markov Chain Monte Carlo Methods for Sampling

Markov Chain Monte Carlo methods, or MCMC, are some of the most popular techniques for sampling from complicated posterior probability distributions or in general from any probability distribution for multi-variate data. Before we get to MCMC, let's talk about Monte Carlo sampling methods in general. Monte Carlo sampling methods try to compute the area under a curve based on sampled points.

For example, the area of the transcendental number $Pi(\pi)$ can be computed by sampling points within a square of radius 1 and noting down the number of sampled points within one-fourth of the circle of diameter 2 enclosed within the square. As shown in Figure 5-2, the area of Pi can be computed as follows:

$$\frac{4 * Area(OAC)}{Area(OABC)} = 4 * \frac{\left(\frac{1}{4}\right) \pi r^2}{r^2} = \pi$$

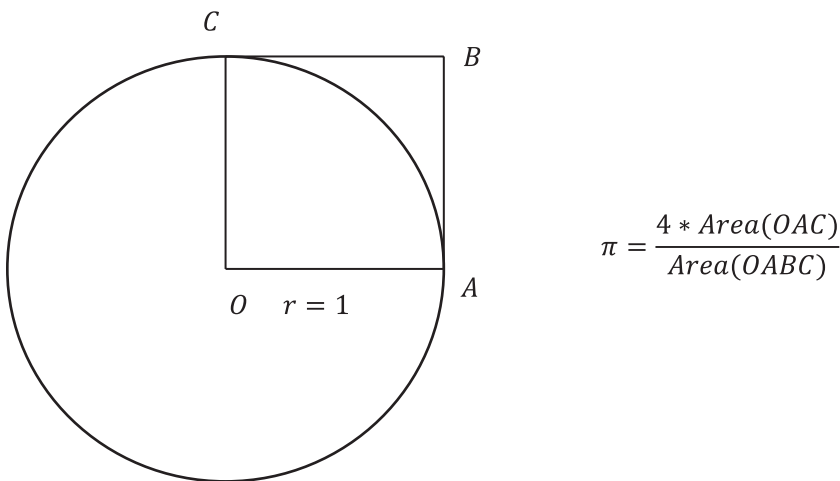

Figure 5-2. Area of Pi

In Listing 5-1, the Monte Carlo method for computing the value of π is illustrated. As we can see, the value comes out to nearly the value of π . The accuracy can be improved by sampling more points.

Listing 5-1. Computation of Pi Through Monte Carlo Sampling

```
import numpy as np
number_sample = 100000
inner_area,outer_area = 0,0
for i in range(number_sample):
    x = np.random.uniform(0,1)
    y = np.random.uniform(0,1)
    if (x**2 + y**2) < 1 :
        inner_area += 1
    outer_area += 1

print("The computed value of Pi:",4*(inner_area/float(outer_area)))
```

```
--Output--
('The computed value of Pi:', 3.142)
```

The simple Monte Carlo method is highly inefficient if the dimension space is large since the larger the dimensionality is the more prominent the effects of correlation are. Markov Chain Monte Carlo methods are efficient in such scenarios since they spend more time collecting samples from high-probability regions than from lower-probability regions. The normal Monte Carlo method explores the probability space uniformly and hence spends as much time exploring low-probability zones as it does high-probability zones. As we know, the contribution of a low-probability zone is insignificant when computing the expectation of functions through sampling, and hence when an algorithm spends a lot of time in such a zone it leads to significantly higher processing time. The main heuristic behind the Markov Chain Monte Carlo method is to explore the probability space not uniformly but rather to concentrate more on the high-probability zones. In high-dimensional space, because of correlation, most of the space is sparse, with high density found only at specific areas. So, the idea is to spend more time and collect more samples from those high-probability zones and spend as little time as possible exploring low-probability zones.

Markov Chain can be thought of as a stochastic/random process to generate a sequence of random samples evolving over time. The next value of the random variable is only determined by the prior value of the variable. Markov Chain, once it enters a high-probability zone, tries to collect as many points with a high-probability density as possible. It does so by generating the next sample, conditioned on the current sample value, so that points near the current sample are chosen with high probability and points far away are chosen with low probability. This ensures that the Markov Chain collects as many points as possible from a current high-probability zone. However, occasionally a long jump from the current sample is required to explore other potential high-probability zones far from the current zone where the Markov Chain is working.

The Markov Chain concept can be illustrated with the movement of gas molecules in an enclosed container at a steady state. A few parts of the container have a higher density of gas molecules than the other areas, and since the gas molecules are at a steady state, the probabilities of each state (determined by the position of a gas molecule) would remain constant even though there might be gas molecules moving from one position to another.

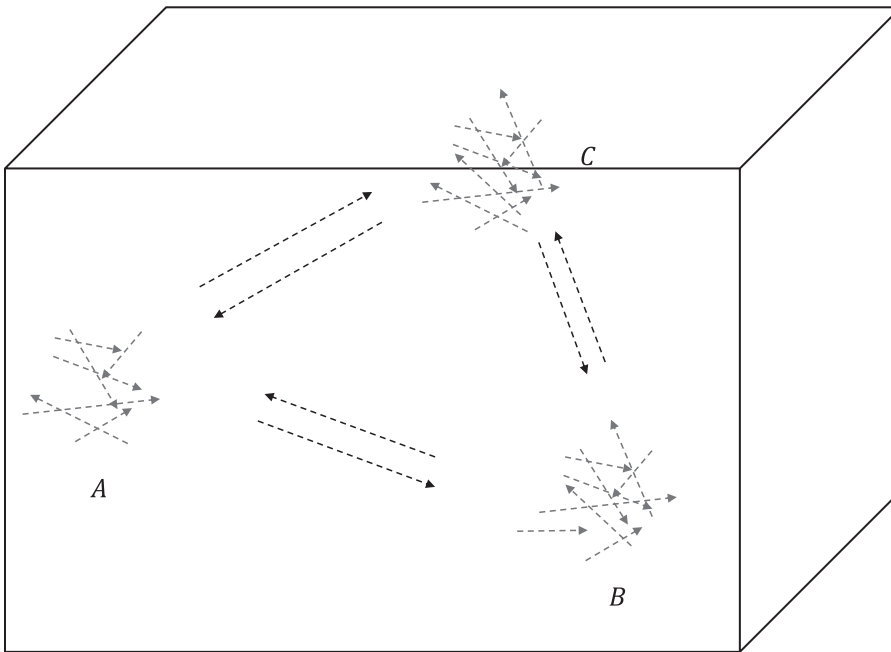

Figure 5-3. Movement of gases in an enclosed container at steady state with only three states: A, B, and C

For simplicity’s sake, let us assume there are only three states (position of the gas molecules, in this case) for the gas molecules, as shown in Figure 5-3. Let us denote those states by A, B, and C and their corresponding probabilities by P_A , P_B , and P_C .

Since the gas molecules are in steady state, if there are gas molecules transitioning to other states, equilibrium needs to be maintained to keep the probability distribution stationary. The simplest assumption to consider is that probability mass going from state A to state B should come back to A from B; i.e., pairwise, the states are in equilibrium.

Let’s say $P(B/A)$ determines the transition probability from A to B. So, probability mass going from A to B is given by

$$P(A)P(B/A) \tag{5.2.1}$$

Likewise, probability mass coming to A from B is given by

$$P(B)P(A/B) \quad (5.2.2)$$

So, in steady state from (5.2.1) and (5.2.2), we have

$$P(A)(B/A) = P(B)P(A/B) \quad (5.2.3)$$

to maintain the stationarity of the probability distribution. This is called a *detailed balance condition*, and it is a sufficient but not necessary condition for the stationarity of a probability distribution. The gas molecules can be in equilibrium in more complex ways, but since this form of detail balance is mathematically convenient when the possible state space is infinite, this approach has been widely used in Markov Chain Monte Carlo methods to sample the next point based on the current point and has a high acceptance probability. In short, movement of the Markov Chain is expected to behave like gas molecules at steady state spending more time in high probability region than in low probability keeping the detailed balance condition intact.

A few other conditions that need to be satisfied for a good implementation of Markov Chain are listed here:

Irreducibility — A desirable property of the Markov Chain is that we can go from one state to any other state. This is important since in Markov Chain, although we want to keep exploring nearby states of a given state with high probability, at times we might have to take a jump and explore some far neighborhood with the expectation that the new zone might be another high-probability zone.

Aperiodicity — The Markov Chain shouldn't repeat too often, as otherwise it won't be possible to traverse the whole space. Imagine a space with 20 states. If, after exploring five states, the chain repeats, it would not be possible to traverse all 20 states, thus leading to sub-optimal sampling.

Metropolis Algorithm

The Metropolis algorithm is a Markov Chain Monte Carlo method that uses the current accepted state to determine the next state. A sample at time $(t+1)$ is conditionally dependent upon the sample at time t . The proposed state at time $(t+1)$ is drawn from a normal distribution with a mean equal to the current sample at time t with a specified variance. Once drawn, the ratio of the probability is checked between the sample at time $(t+1)$ and time t . If $P(x^{(t+1)})/(Px^{(t)})$ is greater than or equal to 1 then the sample $x^{(t+1)}$ is chosen with a probability of 1; if it is less than 1 then the sample is chosen randomly. Mentioned next are the detailed implementation steps.

- Start with any random sample point $X^{(1)}$.
- Choose the next point $X^{(2)}$ that is conditionally dependent on $X^{(1)}$. You can choose $X^{(2)}$ from a normal distribution with a mean of $X^{(1)}$ and some finite variance, let's say $S^{(2)}$. So, $X^{(2)} \sim \text{Normal}(X^{(1)}, S^2)$. A key deciding factor for good sampling is to choose the variance S^2 very judiciously. The variance shouldn't be too large, since in that case the next sample $X^{(2)}$ has less of a chance of staying near the current sample $X^{(1)}$, in which case a high-probability region might not be explored as much since the next sample is selected far away from the current sample most of the time. At the same time, the variance shouldn't be too small. In such cases, the next samples would almost always stay near the current point and hence the probability of exploring a different high-probability zone far from the current zone would reduce.

- Some special heuristics are used in determining whether to accept $X^{(2)}$ once it has been generated from the preceding step.
 - If the ratio $P(X^{(2)})/P(X^{(1)}) \geq 1$ then accept $X^{(2)}$ and keep it as a valid sample point. The accepted sample becomes the $X^{(1)}$ for generating the next sample.
 - If the ratio $P(X^{(2)})/P(X^{(1)}) < 1$, $X^{(2)}$ is accepted if the ratio is greater than a randomly generated number from the uniform distribution between 0 and 1; i.e., $U[0, 1]$.

As we can see, if we move to a higher-probability sample then we accept the new sample, and if we move to a lower-probability sample we sometimes accept and sometimes reject the new sample. The probability of rejection increases if the ratio $P(X^{(2)})/P(X^{(1)})$ is small. Let's say the ratio of $P(X^{(2)})/P(X^{(1)}) = 0.1$. When we generate a random number r_u between 0 and 1 from a uniform distribution, then the probability of $r_u > 0.1$ is 0.9, which in turn implies that the probability of the new sample's getting rejected is 0.9. In general,

$$P(r_u > r) = 1 - r$$

where r is the ratio of the probability of the new sample and the old sample.

Let's try to intuit why such heuristics work for Markov Chain Monte Carlo methods. As per detailed balance,

$$P(X^{(1)})P(X^{(2)} / X^{(1)}) = P(X^{(2)})P(X^{(1)} / X^{(2)})$$

We are assuming that the transition probabilities follow normal distribution. We are not checking whether the transition probability framework we have taken is enough to maintain the stationarity of the probability distribution in the form of detailed balance that we wish to adhere to. Let us consider that the ideal transition probabilities between the two states X_1 and X_2 to maintain the stationarity of the distribution is given by $P(X_1/X_2)$ and $P(X_2/X_1)$. Hence, as per detailed balance, the following condition must be satisfied:

$$P(X_1 / X_2)P(X_1) = P(X_2 / X_1)P(X_2)$$

However, discovering such an ideal transition probability function that ensures stationarity by imposing a detailed balance condition is hard. We start off with a suitable transition probability function, let's say $T(x/y)$, where y denotes the current state and x denotes the next state to be sampled based on y . For the two states X_1 and X_2 the assumed transition probabilities are thus given by $T(X_1/X_2)$ for a move from state X_2 to X_1 and by $T(X_2/X_1)$ for a move from state X_1 to X_2 . Since the assumed transition probabilities are different than the ideal transition probabilities required to maintain stationarity through detailed balance, we get the opportunity to accept or reject samples based on how good the next move is. To cover up this opportunity, an acceptance probability for the transition of states is considered such that for a transition of a state from X_1 to X_2

$$P(X_2 / X_1) = T(X_2 / X_1)A(X_2 / X_1)$$

where $A(X_2/X_1)$ is the acceptance probability of the move from X_1 to X_2 .

As per detailed balance,

$$P(X_1 / X_2)P(X_1) = P(X_2 / X_1)P(X_2)$$

Replacing the ideal transition probability as the product of the assumed transition probability and the acceptance probability we get

$$T(X_2 / X_1)A(X_2 / X_1)P(X_1) = T(X_1 / X_2)A(X_1 / X_2)P(X_2)$$

Rearranging this, we get the acceptance probability ratio as

$$\frac{A(X_2 / X_1)}{A(X_1 / X_2)} = \frac{T(X_1 / X_2)P(X_2)}{T(X_2 / X_1)P(X_1)}$$

One simple proposal that satisfies this is given by the Metropolis algorithm as

$$A(X_2 / X_1) = \min\left(1, \frac{T(X_1 / X_2)P(X_2)}{T(X_2 / X_1)P(X_1)}\right)$$

In the Metropolis algorithm, the assumed transitional probability is generally assumed to be a normal distribution that is symmetric, and hence $T(X_1 / X_2) = T(X_2 / X_1)$. This simplifies the acceptance probability of the move from X_1 to X_2 as

$$A(X_2 / X_1) = \min\left(1, \frac{P(X_2)}{P(X_1)}\right)$$

If the acceptance probability is 1, then we accept the move with probability 1, while if the acceptance probability is less than 1, let's say r , then we accept the new sample with probability r and reject the sample with probability $(1-r)$. This rejection of samples with the probability $(1-r)$ is achieved by comparing the ratio with the randomly generated sample r_u from a uniform distribution between 0 and 1 and rejecting the sample in cases where $r_u > r$. This is because for a uniform distribution probability $P(r_u > r) = 1-r$, which ensures the desired rejection probability is maintained.

In Listing 5-2 we illustrate the sampling from a bivariate Gaussian distribution through the Metropolis algorithm.

Listing 5-2. Bivariate Gaussian Distribution Through Metropolis Algorithm

```
import numpy as np
import matplotlib.pyplot as plt
#Now let's generate this with one of the Markov Chain Monte Carlo methods called Metropolis
Hastings algorithm
# Our assumed transition probabilities would follow normal distribution X2 ~
N(X1,Covariance= [[0.2 , 0],[0,0.2]])

import time
start_time = time.time()
```

```

# Set up constants and initial variable conditions
num_samples=100000
prob_density = 0
## Plan is to sample from a Bivariate Gaussian Distribution with mean (0,0) and covariance of
## 0.7 between the two variables
mean = np.array([0,0])
cov = np.array([[1,0.7],[0.7,1]])
cov1 = np.matrix(cov)
mean1 = np.matrix(mean)
x_list,y_list = [],[]
accepted_samples_count = 0
## Normalizer of the Probability distribution
## This is not actually required since we are taking ratio of probabilities for inference
normalizer = np.sqrt( ((2*np.pi)**2)*np.linalg.det(cov))
## Start with initial Point (0,0)
x_initial, y_initial = 0,0
x1,y1 = x_initial, y_initial

for i in xrange(num_samples):
    ## Set up the Conditional Probability distribution, taking the existing point
    ## as the mean and a small variance = 0.2 so that points near the existing point
    ## have a high chance of getting sampled.
    mean_trans = np.array([x1,y1])
    cov_trans = np.array([[0.2,0],[0,0.2]])
    x2,y2 = np.random.multivariate_normal(mean_trans,cov_trans).T
    X = np.array([x2,y2])
    X2 = np.matrix(X)
    X1 = np.matrix(mean_trans)
    ## Compute the probability density of the existing point and the new sampled
    ## point
    mahalnobis_dist2 = (X2 - mean1)*np.linalg.inv(cov)*(X2 - mean1).T
    prob_density2 = (1/float(normalizer))*np.exp(-0.5*mahalnobis_dist2)
    mahalnobis_dist1 = (X1 - mean1)*np.linalg.inv(cov)*(X1 - mean1).T
    prob_density1 = (1/float(normalizer))*np.exp(-0.5*mahalnobis_dist1)
    ## This is the heart of the algorithm. Comparing the ratio of probability density
    ## of the new
    ## point and the existing point(acceptance_ratio) and selecting the new point if it is
    ## to have more probability
    ## density. If it has less probability it is randomly selected with the probability
    ## of getting
    ## selected being proportional to the ratio of the acceptance ratio
    acceptance_ratio = prob_density2[0,0] / float(prob_density1[0,0])

    if (acceptance_ratio >= 1) | ((acceptance_ratio < 1) and (acceptance_ratio >= np.random.
uniform(0,1)) ):
        x_list.append(x2)
        y_list.append(y2)
        x1 = x2
        y1 = y2
        accepted_samples_count += 1

```

```

end_time = time.time()

print ('Time taken to sample ' + str(accepted_samples_count) + ' points ==> ' + str(end_time -
start_time) + ' seconds' )
print 'Acceptance ratio ==> ' , accepted_samples_count/float(100000)
## Time to display the samples generated
plt.xlabel('X')
plt.ylabel('Y')
plt.scatter(x_list,y_list,color='black')
print "Mean of the Sampled Points"
print np.mean(x_list),np.mean(y_list)
print "Covariance matrix of the Sampled Points"
print np.cov(x_list,y_list)

```

-Output-

```

Time taken to sample 71538 points ==> 30.3350000381 seconds
Acceptance ratio ==> 0.71538
Mean of the Sampled Points
-0.0090486292629 -0.008610932357
Covariance matrix of the Sampled Points
[[ 0.96043199  0.66961286]
 [ 0.66961286  0.94298698]]

```

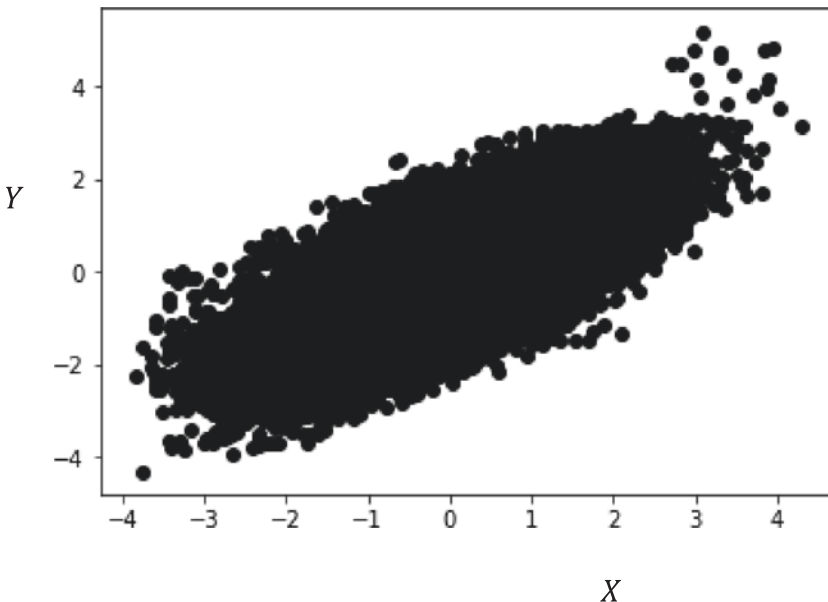

Figure 5-4. Plot of sampled points from multi-variate Gaussian distribution using Metropolis algorithm

We see from the output that the mean and the covariance of the sampled points closely represent the mean and covariance of the bivariate Gaussian distribution from which we are sampling. Also, the scatter plot in Figure 5-4 closely resembles the bivariate Gaussian distribution.

Now that we are aware of the Markov Chain Monte Carlo methods of sampling from probability distribution, we will learn about another MCMC method called Gibbs sampling while examining restricted Boltzmann machines.

Restricted Boltzmann Machines

Restricted Boltzmann machines (RBMs) belong to the unsupervised class of machine-learning algorithms that utilize the Boltzmann Equation of Probability Distribution. Illustrated in Figure 5-5 is a two-layer restricted Boltzmann machine architecture that has a hidden layer and a visible layer. There are weight connections between all the hidden and visible layers' units. However, there are no hidden-to-hidden or visible-to-visible unit connections. The term *restricted* in RBM refers to this constraint on the network. The hidden units of an RBM are conditionally independent from one another given the set of visible units. Similarly, the visible units of an RBM are conditionally independent from one another given the set of hidden units. Restricted Boltzmann machines are most often used as a building block for deep networks rather than as an individual network itself. In terms of probabilistic graphic models, restricted Boltzmann machines can be defined as undirected probabilistic graphic models containing a visible layer and a single hidden layer. Much like PCA, RBMs can be thought of as a way of representing data in one dimension (given by the visible layer v) into a different dimension (given by the hidden or latent layer h). When the size of the hidden layer is less than the size of the visible layer then RBMs perform a dimensionality reduction of data. RBMs are generally trained on binary data.

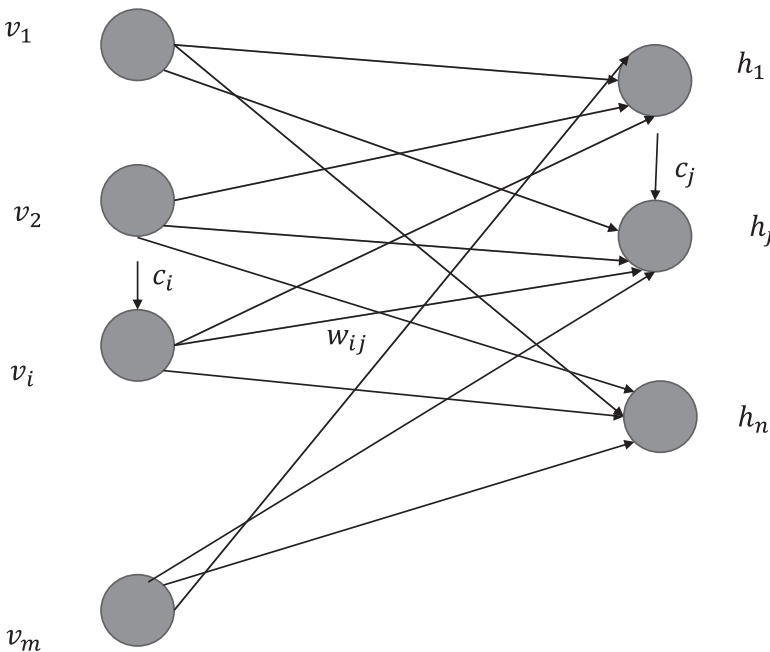

Figure 5-5. Restricted Boltzmann machine visible and hidden layers architecture

Let the visible units of the RBM be represented by vector $v = [v_1 v_2 \dots v_m]^T \in \mathbb{R}^{m \times 1}$ and the hidden units be represented by $h = [h_1 h_2 \dots h_n]^T \in \mathbb{R}^{n \times 1}$. Also, let the weight connecting the i th visible unit to the j th hidden unit be represented by w_{ij} , $\forall i \in \{1, 2, \dots, m\}$, $\forall j \in \{1, 2, \dots, n\}$. Let the matrix containing the weights w_{ij} be represented by $W \in \mathbb{R}^{m \times n}$.

The energy of the joint probability distribution's having hidden state h and visible state v is given by

$$P(v, h) = \frac{e^{-E(h, v)}}{Z} \quad (5.3.1)$$

where $E(v, h)$ is the energy of the joint configuration (v, h) and Z is the normalizing factor, commonly known as the partition function. This probability is based on the Boltzmann distribution and assumes the Boltzmann Constant and thermal temperature as 1.

$$Z = \sum_v \sum_h e^{-E(v, h)} \quad (5.3.2)$$

The energy $E(v, h)$ of the joint configuration (v, h) is given by

$$E(v, h) = -b^T v - c^T h - v^T W h \quad (5.3.3)$$

$$E(v, h) = -\sum_{i=1}^m b_i v_i - \sum_{j=1}^n c_j h_j - \sum_{j=1}^n \sum_{i=1}^m v_i w_{ij} h_j \quad (5.3.4)$$

The vectors $b \in [b_1 b_2 \dots b_m]^T \in \mathbb{R}^{m \times 1}$ and $c \in [c_1 c_2 \dots c_n]^T \in \mathbb{R}^{n \times 1}$ are biases at the visible and hidden units respectively, as we will see later.

In any graphical probabilistic model, the idea is to compute the joint probability distribution over various sets of events. Combining (5.3.1) and (5.3.3), we get

$$P(v, h) = \frac{e^{b^T v + c^T h + v^T W h}}{Z} \quad (5.3.5)$$

The partition function Z is hard to compute, which makes the computation of $P(v, h)$ hard to compute. For a small set of events, it is possible to compute the partition function. If there are many variables in v and h , the number of possible joint events will be exceedingly large; considering all such combinations becomes hard.

However, the conditional probability distribution $P(h/v)$ is easy to compute and sample from. The following deduction will justify this:

$$\begin{aligned}
 P(h/v) &= \frac{P(v,h)}{P(v)} \\
 &= \frac{P(v,h)}{\sum_h P(v,h)} \\
 &= \frac{e^{b^T v + c^T h + v^T W h}}{Z} \\
 &= \frac{e^{b^T v + c^T h + v^T W h}}{\sum_h \frac{e^{b^T v + c^T h + v^T W h}}{Z}} \\
 &= \frac{e^{b^T v + c^T h + v^T W h}}{\sum_h e^{b^T v + c^T h + v^T W h}} \\
 &= \frac{e^{b^T v} e^{c^T h} e^{v^T W h}}{e^{b^T v} \sum_h e^{c^T h} e^{v^T W h}} \\
 &= \frac{e^{c^T h} e^{v^T W h}}{\sum_h e^{c^T h} e^{v^T W h}}
 \end{aligned}$$

We can expand the numerator and denominator in terms of the components of the different vectors involved, as follows:

$$\begin{aligned}
 e^{c^T h} e^{v^T W h} &= e^{c^T h + v^T W h} \\
 &= e^{\sum_{j=1}^n (c_j h_j + v^T W_{[:j]} h_j)}
 \end{aligned}$$

Since the exponential of a sum is equal to the product of the exponentials, the preceding equation can be written in product form as follows:

$$e^{c^T h} e^{v^T W h} = \prod_{j=1}^n e^{c_j h_j + v^T W_{[:j]} h_j} \tag{5.3.6}$$

Now, let's look at the denominator, which looks similar to the numerator only with a sum of all possible hidden states h . Using the expression for $e^{c^T h} e^{v^T W h}$ in (5.3.6), the denominator can be expressed as

$$\sum_h e^{c^T h} e^{v^T W h} = \sum_h \prod_{j=1}^n e^{c_j h_j + v^T W_{[:j]} h_j} \tag{5.3.7}$$

The sum over vector means the sum over all combinations of its components. Each hidden unit h_i can have a binary state of 0 or 1, and hence $h_j \in \{0,1\} \forall j \in \{1,2,3,..,n\}$. So, the summation over vector h in (5.3.7) can be expanded into multiple summations corresponding to each of its components:

$$\begin{aligned} \sum_h e^{c^T h} e^{v^T W h} &= \sum_{h_1=0}^1 \sum_{h_2=0}^1 \dots \sum_{h_n=0}^1 \prod_{j=1}^n e^{c_j h_j + v^T W[:,j] h_j} \\ &= \sum_{h_1=0}^1 \sum_{h_2=0}^1 \dots \sum_{h_n=0}^1 \left(e^{c_1 h_1 + v^T W[:,1] h_1} \right) \left(e^{c_2 h_2 + v^T W[:,2] h_2} \right) \dots \left(e^{c_n h_n + v^T W[:,n] h_n} \right) \end{aligned} \quad (5.3.8)$$

Now, let's look at a very simple manipulation involving products and sums with two discrete variables a and b :

$$\begin{aligned} \sum_{j=1}^2 \sum_{i=1}^3 a_i b_j &= a_1 b_1 + a_2 b_1 + a_3 b_1 + a_1 b_2 + a_2 b_2 + a_3 b_2 \\ &= b_1 (a_1 + a_2 + a_3) + b_2 (a_1 + a_2 + a_3) \\ &= (a_1 + a_2 + a_3) (b_1 + b_2) \\ &= \left(\sum_{i=1}^3 a_i \right) \left(\sum_{j=1}^2 b_j \right) \end{aligned}$$

So, we see that when we take elements of variables with independent indices the sum of the products of the variables can be expressed as the product of the sum of the variables. Similar to this example, the elements of h (i.e., h_i) in general are involved in the product $\left(e^{c_1 h_1 + v^T W[:,1] h_1} \right) \left(e^{c_2 h_2 + v^T W[:,2] h_2} \right) \dots \left(e^{c_n h_n + v^T W[:,n] h_n} \right)$ independently, and hence the expression in (5.3.8) can be simplified as follows:

$$\begin{aligned} \sum_h e^{c^T h} e^{v^T W h} &= \sum_{h_1=0}^1 \left(e^{c_1 h_1 + v^T W[:,1] h_1} \right) \sum_{h_2=0}^1 \left(e^{c_2 h_2 + v^T W[:,2] h_2} \right) \dots \sum_{h_n=0}^1 \left(e^{c_n h_n + v^T W[:,n] h_n} \right) \\ &= \prod_{j=1}^n \sum_{h_j=0}^1 \left(e^{c_j h_j + v^T W[:,j] h_j} \right) \end{aligned} \quad (5.3.9)$$

Combining the expressions for numerator and denominator from (5.3.6) and (5.3.9), we have

$$P(h/v) = \frac{\prod_{j=1}^n e^{c_j h_j + v^T W[:,j] h_j}}{\prod_{j=1}^n \sum_{h_j=0}^1 e^{c_j h_j + v^T W[:,j] h_j}}$$

Simplifying this in terms of components of h on both sides, we get

$$\begin{aligned}
 P(h_1 h_2 \dots h_n / v) &= \prod_{j=1}^n \left(\frac{e^{c_j h_j + v^T W[:,j] h_j}}{\sum_{h_j=0}^1 e^{c_j h_j + v^T W[:,j] h_j}} \right) \\
 &= \left(\frac{e^{c_1 h_1 + v^T W[:,1] h_1}}{\sum_{h_1=0}^1 e^{c_1 h_1 + v^T W[:,1] h_1}} \right) \left(\frac{e^{c_2 h_2 + v^T W[:,2] h_2}}{\sum_{h_2=0}^1 e^{c_2 h_2 + v^T W[:,2] h_2}} \right) \dots \left(\frac{e^{c_n h_n + v^T W[:,n] h_n}}{\sum_{h_n=0}^1 e^{c_n h_n + v^T W[:,n] h_n}} \right) \tag{5.3.10}
 \end{aligned}$$

The joint probability distribution of elements of h conditioned on v has factored into the product of expressions independent of each other conditioned on v . This leads to the fact that the components of h (i.e., $h_i \forall i \in \{1, 2, \dots, n\}$) are conditionally independent of each other given v . This gives us

$$P(h_1 h_2 \dots h_n / v) = P(h_1 / v) P(h_2 / v) \dots P(h_n / v) \tag{5.3.11}$$

$$P(h_j / v) = \frac{e^{c_j h_j + v^T W[:,j] h_j}}{\sum_{h_j=0}^1 e^{c_j h_j + v^T W[:,j] h_j}} \tag{5.3.12}$$

Replacing $h_j = 1$ and $h_j = 0$ in (5.3.12), we get

$$P(h_j = 1 / v) = \frac{e^{c_j + v^T W[:,j]}}{1 + e^{c_j + v^T W[:,j]}} \tag{5.3.13}$$

$$P(h_j = 0 / v) = \frac{1}{1 + e^{c_j + v^T W[:,j]}} \tag{5.3.14}$$

The expressions for (5.3.13) and (5.3.14) illustrate the fact that the hidden units $h_i \forall i \in \{1, 2, \dots, n\}$ are independent sigmoid units:

$$P(h_j = 1 / v) = \sigma(c_j + v^T W[:,j]) \tag{5.3.15}$$

Expanding the components of v and $W[:,j]$, we can rewrite (5.3.15) as

$$P(h_j = 1 / v) = \sigma\left(c_j + \sum_{i=1}^m v_i w_{ij}\right) \tag{5.3.16}$$

where $\sigma(\cdot)$ represents the sigmoid function such that

$$\sigma(x) = \frac{1}{(1 + e^{-x})}$$

Proceeding in a similar fashion, it can be proved that

$$P(v_1 v_2 \dots v_m / h) = P(v_1 / h) P(v_2 / h) \dots P(v_m / h)$$

which means the hidden units are conditionally independent of each other given the visible states. Since RBM is a symmetrical undirected network, like the visible units, the probability of the visible units given the hidden states can be similarly expressed as

$$P(v_i = 1 / h) = \sigma \left(b_i + \sum_{j=1}^n h_j w_{ij} \right) \quad (5.3.17)$$

From (5.3.16) and (5.3.17) we can clearly see that the visible and hidden units are actually binary sigmoid units with the vectors b and c providing the biases at the visible and hidden units respectively. This symmetrical and independent conditional dependence of the hidden and visible units can be useful while training the model.

Training a Restricted Boltzmann Machine

We need to train the Boltzmann machine in order to derive the model parameters b, c, W , where b and c are the bias vectors at the visible and hidden units respectively and W is the weight-connections matrix between the visible and hidden layers. For ease of reference, the model parameters can be collectively referred to as

$$\theta = [b; c; W]$$

The model can be trained by maximizing the log likelihood function of the input data points with respect to the model parameters. The input is nothing but the data corresponding to the visible units for each data point. The likelihood function is given by

$$L(\theta) = P(v^{(1)} v^{(2)} \dots v^{(m)} / \theta)$$

Since the input's data points are independent given the model,

$$L(\theta) = P(v^{(1)} / \theta) P(v^{(2)} / \theta) \dots P(v^{(m)} / \theta) = \prod_{t=1}^m P(v^{(t)} / \theta) \quad (5.3.18)$$

Taking the log on both sides to get the log likelihood expression of the function in (5.3.18), we have

$$C = \log L(\theta) = \sum_{t=1}^m \log P(v^{(t)} / \theta) \quad (5.3.19)$$

Expanding the probabilities in (5.3.19) by its joint probability form, we get

$$\begin{aligned}
 C &= \sum_{t=1}^m \log P(v^{(t)} / \theta) \\
 &= \sum_{t=1}^m \log \sum_h P(v^{(t)}, h / \theta) \\
 &= \sum_{t=1}^m \log \sum_h \frac{e^{-E(v^{(t)}, h)}}{Z} \\
 &= \sum_{t=1}^m \log \frac{\sum_h e^{-E(v^{(t)}, h)}}{Z} \\
 &= \sum_{t=1}^m \log \sum_h e^{-E(v^{(t)}, h)} - \sum_{t=1}^m \log Z \\
 &= \sum_{t=1}^m \log \sum_h e^{-E(v^{(t)}, h)} - m \log Z
 \end{aligned} \tag{5.3.20}$$

The partition function Z is not constrained by visible-layer inputs $v^{(t)}$ unlike the first term in (5.3.20). Z is the sum of the negative exponentials of the energies over all possible combinations of v and h and so can be expressed as

$$Z = \sum_v \sum_h e^{-E(v, h)}$$

Replacing Z with this expression in (5.3.20), we get

$$C = \sum_{t=1}^m \log \sum_h e^{-E(v^{(t)}, h)} - m \log \sum_v \sum_h e^{-E(v, h)} \tag{5.3.21}$$

Now, let's take the gradient of the cost function with respect to the combined parameter θ . We can think of C as comprising two components, ρ^+ and ρ^- , where

$$\begin{aligned}
 \rho^+ &= \sum_{t=1}^m \sum_h e^{-E(v^{(t)}, h)} \\
 \rho^- &= m \log \sum_v \sum_h e^{-E(v, h)}
 \end{aligned}$$

Taking the gradient of ρ^+ with respect to θ , we have

$$\nabla_{\theta}(\rho^+) = \sum_{t=1}^m \frac{\sum_h e^{-E(v^{(t)}, h)} \nabla_{\theta}(-E(v^{(t)}, h))}{\sum_h e^{-E(v^{(t)}, h)}} \tag{5.3.22}$$

Now, let's simplify $\frac{\sum_h e^{-E(v^{(t)}, h)} \nabla_{\theta} (-E(v^{(t)}, h))}{\sum_h e^{-E(v^{(t)}, h)}}$ by dividing both the numerator and the denominator by Z :

$$\nabla_{\theta}(\rho^+) = \frac{\sum_{t=1}^m \sum_h \frac{e^{-E(v^{(t)}, h)}}{Z} \nabla_{\theta} (-E(v^{(t)}, h))}{\frac{\sum_h e^{-E(v^{(t)}, h)}}{Z}} \quad (5.3.23)$$

$\frac{e^{-E(v^{(t)}, h)}}{Z} = P(v^{(t)}, h/\theta)$ and $\frac{\sum_h e^{-E(v^{(t)}, h)}}{Z} = P(v^{(t)}/\theta)$. Using these expressions for the probabilities in (5.3.23), we get

$$\begin{aligned} \nabla_{\theta}(\rho^+) &= \frac{\sum_{t=1}^m \sum_h P(v^{(t)}, h/\theta) \nabla_{\theta} (-E(v^{(t)}, h))}{P(v^{(t)}/\theta)} \\ &= \sum_{t=1}^m \sum_h \frac{P(v^{(t)}, h/\theta)}{P(v^{(t)}/\theta)} \nabla_{\theta} (-E(v^{(t)}, h)) \\ &= \sum_{t=1}^m \sum_h P(h/v^{(t)}, \theta) \nabla_{\theta} (-E(v^{(t)}, h)) \end{aligned} \quad (5.3.24)$$

One can remove the θ from the probability notations, such as $P(v^{(t)}, h/\theta)$, $P(v^{(t)}, h/\theta)$, and so forth, for ease of notation if one wishes to, but it is better to keep them since it makes the deductions more complete, which allows for better interpretability of the overall training process.

Let us look at the expectation of functions, which gives us the expression seen in (5.3.24) in a more meaningful form ideal for training purposes. The expectation of $f(x)$, given x , follows probability mass function $P(x)$ and is given by

$$E[f(x)] = \sum_x P(x) f(x)$$

If $x = [x_1, x_2, \dots, x_n]^T \in \mathbb{R}^{n \times 1}$ is multi-variate, then the preceding expression holds true and

$$E[f(x)] = \sum_x P(x) f(x) = \sum_{x_1} \sum_{x_2} \dots \sum_{x_n} P(x_1, x_2, \dots, x_n) f(x_1, x_2, \dots, x_n)$$

Similarly, if $f(x)$ is a vector of functions such that $f(x) = [f_1(x), f_2(x)]^T$, one can use the same expression as for expectation. Here, one would get a vector of expectations, as follows:

$$E[f(x)] = \sum_x P(x) f(x) = \begin{bmatrix} \sum_{x_1} \sum_{x_2} \dots \sum_{x_n} P(x_1, x_2, \dots, x_n) f_1(x_1, x_2, \dots, x_n) \\ \sum_{x_1} \sum_{x_2} \dots \sum_{x_n} P(x_1, x_2, \dots, x_n) f_2(x_1, x_2, \dots, x_n) \end{bmatrix} \quad (5.3.25)$$

To explicitly mention the probability distribution in the expectation notation, one can rewrite the expectation of functions or expectation of vector of functions whose variables x follow probability distribution $P(x)$ as follows:

$$E_{P(x)}[f(x)] = \sum_x P(x) f(x)$$

Since we are working with gradients, which are vectors of different partial derivatives, and each of the partial derivatives is a function of h for given values of θ and v , the expression in (5.3.24) can be expressed in terms of expectation of the gradient $\nabla_{\theta}(-E(v^{(t)}, h))$ with respect to the probability distribution $P(h/v^{(t)}, \theta)$ as

$$\nabla_{\theta}(\rho^+) = \sum_{t=1}^m E_{P(h/v^{(t)}, \theta)} \left[\nabla_{\theta}(-E(v^{(t)}, h)) \right] \quad (5.3.26)$$

Note that the expectation $E_{P(h/v^{(t)}, \theta)} \left[\nabla_{\theta}(-E(v^{(t)}, h)) \right]$ is a vector of expectations, as has been illustrated in (5.3.25).

Now, let's get to the gradient of $\rho^- = m \log \sum_v \sum_h e^{-E(v, h)}$ with respect to the θ :

$$\begin{aligned} \nabla_{\theta}(\rho^-) &= m \frac{\sum_v \sum_h e^{-E(v, h)} \nabla_{\theta}(-E(v, h))}{\sum_v \sum_h e^{-E(v, h)}} \\ &= m \frac{\sum_v \sum_h e^{-E(v, h)} \nabla_{\theta}(-E(v, h))}{Z} \\ &= m \sum_v \sum_h \frac{e^{-E(v, h)}}{Z} \nabla_{\theta}(-E(v, h)) \\ &= m \sum_v \sum_h P(v, h / \theta) \nabla_{\theta}(-E(v, h)) \\ &= m E_{P(h, v / \theta)} \left[\nabla_{\theta}(-E(v, h)) \right] \end{aligned} \quad (5.3.27)$$

The expectation in (5.3.27) is over the joint distribution of h and v whereas the expectation in (5.3.26) is over the h given a seen v . Combining (5.3.26) and (5.3.27), we get

$$\nabla_{\theta}(C) = \sum_{t=1}^m E_{P(h/v^{(t)}, \theta)} \left[\nabla_{\theta}(-E(v^{(t)}, h)) \right] - m E_{P(h, v / \theta)} \left[\nabla_{\theta}(-E(v, h)) \right] \quad (5.3.28)$$

If we look at the gradient with respect to all the parameters in (5.3.28) it has two terms. The first term is dependent on the seen data $v^{(t)}$, while the second term depends on samples from the model. The first term increases the likelihood of the given observed data while the second term reduces the likelihood of data points from the model.

Now, let's do some simplification of the gradient for each of the parameter sets in θ ; i.e. b , c , and W .

$$\nabla_b(-E(v, h)) = \nabla_b(b^T v + c^T h + v^T W h) = v \quad (5.3.29)$$

$$\nabla_c(-E(v, h)) = \nabla_c(b^T v + c^T h + v^T W h) = h \quad (5.3.30)$$

$$\nabla_w(-E(v, h)) = \nabla_w(b^T v + c^T h + v^T W h) = v h^T \quad (5.3.31)$$

Using (5.3.28) through (5.3.31), the expression for the gradient with respect to each of the parameter sets is given by

$$\nabla_b(C) = \sum_{t=1}^m E_{P(h/v^{(t)}, \theta)}[v^{(t)}] - m E_{P(h, v/\theta)}[v] \quad (5.3.32)$$

Since the probability distribution of the first term is conditioned on $v^{(t)}$, the expectation of $v^{(t)}$ with respect to $P(h/v^{(t)}, \theta)$ is $v^{(t)}$.

$$\nabla_b(C) = \sum_{t=1}^m v^{(t)} - m E_{P(h, v/\theta)}[v] \quad (5.3.33)$$

$$\nabla_c(C) = \sum_{t=1}^m E_{P(h/v^{(t)}, \theta)}[h] - m E_{P(h, v/\theta)}[h] \quad (5.3.34)$$

The expectation of h over the probability distribution $P(h/v^{(t)}, \theta)$ can be easily computed since each of the units of h (i.e., h_j) given $v^{(t)}$ is independent. Each of them is a sigmoid unit with two possible outcomes, and their expectation is nothing but the output of the sigmoid units; i.e.,

$$E_{P(h/v^{(t)}, \theta)}[h] = \hat{h}^{(t)} = \sigma(c + W^T v^{(t)})$$

If we replace the expectation with \hat{h} then the expression in (5.3.34) can be written as

$$\nabla_c(C) = \sum_{t=1}^m \hat{h}^{(t)} - m E_{P(h, v/\theta)}[h] \quad (5.3.35)$$

Similarly,

$$\begin{aligned} \nabla_w(C) &= \sum_{t=1}^m E_{P(h/v^{(t)}, \theta)}[v^{(t)} h^T] - m E_{P(h, v/q)}[h] \\ &= \sum_{t=1}^m v^{(t)} \hat{h}^{(t)T} - m E_{P(h, v/\theta)}[h] \end{aligned} \quad (5.3.36)$$

So, the expressions in (5.3.33), (5.3.35), and (5.3.36) represent the gradients with respect to the three parameter sets. For easy reference:

$$\begin{cases} \nabla_b(C) = \sum_{t=1}^m v^{(t)} - mE_{P(h,v/\theta)}[v] \\ \nabla_c(C) = \sum_{t=1}^m \hat{h}^{(t)} - mE_{P(h,v/\theta)}[h] \\ \nabla_w(C) = \sum_{t=1}^m v^{(t)} \hat{h}^{(t)\top} - mE_{P(h,v/\theta)}[hv] \end{cases} \tag{5.3.37}$$

Based on these gradients, gradient-descent techniques can be invoked to iteratively get the parameter values that maximize the likelihood function. However, there is a little complexity involved to compute the expectations with respect to the joint probability distribution $P(h, v/\theta)$ at each iteration of gradient descent. The joint distribution is hard to compute because of the seemingly large number of combinations for h and v in cases where they are moderate to large dimensionality vectors. Markov Chain Monte Carlo sampling (MCMC) techniques, especially Gibbs Sampling, can be used to sample from the joint distribution and compute the expectations in (5.3.37) for the different parameter sets. However, MCMC techniques take a long time to converge to a stationary distribution, after which they provide good samples. Hence, to invoke MCMC sampling at each iteration of gradient descent would make the learning very slow and impractical.

Gibbs Sampling

Gibbs sampling is a Markov Chain Monte Carlo method that can be used to sample observations from a multi-variate probability distribution. Suppose we want to sample from a multi-variate joint probability distribution $P(x)$ where $x = [x_1, x_2, \dots, x_n]^T$.

Gibbs sampling generates the next value of a variable x_i conditioned on all the current values of the other variables. Let the t -th sample drawn be represented by $x^{(t)} = [x_1^{(t)}, x_2^{(t)}, \dots, x_n^{(t)}]^T$. To generate the $(t+1)$ sample seen next, follow this logic:

- Draw the variable $x_j^{(t+1)}$ by sampling it from a probability distribution conditioned on the rest of the variables. In other words, draw $x_j^{(t+1)}$ from

$$P\left(x_j^{(t+1)} / x_1^{(t+1)}, x_1^{(t+1)}, \dots, x_{j-1}^{(t+1)}, x_{j+1}^{(t)}, \dots, x_n^{(t)}\right)$$

So basically, for sampling x_j conditioned on the rest of the variables, for the $j-1$ variables before x_j their values for the $(t+1)$ instance are considered since they have already been sampled, while for the rest of the variables their values at instance t are considered since they are yet to be sampled. This step is repeated for all the variables.

If each x_j is discrete and can take, let's say, two values 0 and 1, then we need to compute the probability $p_1 = P\left(x_j^{(t+1)} = 1 / x_1^{(t+1)}, x_2^{(t+1)}, \dots, x_{j-1}^{(t+1)}, x_{j+1}^{(t)}, \dots, x_n^{(t)}\right)$. We can then draw a sample u from a uniform probability distribution between 0 and 1 (i.e., $U[0, 1]$), and if $p_1 \geq u$ set $x_j^{(t+1)} = 1$, else set $x_j^{(t+1)} = 0$. This kind of random heuristics ensure that the higher the probability p_1 is, the greater the chances are of $x_j^{(t+1)}$ getting selected as 1. However, it still leaves room for 0 getting selected

with very low probability, even if p_1 is relatively large, thus ensuring that the Markov Chain doesn't get stuck in a local region and can explore other potential high-density regions as well. There are the same kind of heuristics that we saw for the Metropolis algorithm as well.

- If one wishes to generate m samples from the joint probability distribution $P(x)$ the preceding step has to be repeated m times.

The conditional distributions for each variable based on the joint probability distribution are to be determined before the sampling can proceed. If one is working on Bayesian networks or restricted Boltzmann machines, there are certain constraints within the variables that help determine these conditional distributions in an efficient manner.

As an example, if one needs to do Gibbs sampling from a bivariate normal distribution with mean $[0\ 0]$ and covariance matrix $\begin{bmatrix} 1 & \rho \\ \rho & 1 \end{bmatrix}$, then the conditional probability distributions can be computed as follows:

$$P(x_2 / x_1) = P(x_1, x_2) / P(x_1)$$

$$P(x_1 / x_2) = P(x_1, x_2) / P(x_2)$$

If one derives the marginal distributions $P(x_1)$ and $P(x_2)$ as $\int_{x_2} P(x_1, x_2) dx_2$ and $\int_{x_1} P(x_1, x_2) dx_1$, then

$$x_2 / x_1 \sim \text{Normal}(\rho x_1, 1 - \rho^2)$$

$$x_1 / x_2 \sim \text{Normal}(\rho x_2, 1 - \rho^2)$$

Block Gibbs Sampling

There are several variants of Gibbs sampling. Block Gibbs sampling is one of them. In Block Gibbs sampling, more than one variable is grouped together, and then the group of variables is sampled together conditioned on the rest of the variables, as opposed to sampling for individual variables separately. For example, in a restricted Boltzmann machine the hidden unit state variables $h = [h_1\ h_2 \dots h_n]^T \in \mathbb{R}^{n \times 1}$ can be sampled together conditioned on the visible unit states $v = [v_1\ v_2 \dots v_m]^T \in \mathbb{R}^{m \times 1}$ and vice versa. Hence, for sampling from the joint probability distribution over $P(v, h)$, through Block Gibbs sampling one can sample all the hidden states given the visible unit states through the conditional distribution $P(h/v)$ and sample all the visible unit states given the hidden unit states through the conditional distribution $P(v/h)$. The samples at the $(t+1)$ iteration of Gibbs sampling can be generated as

$$h^{(t+1)} \sim P(h/v^{(t)})$$

$$v^{(t+1)} \sim P(v/h^{(t+1)})$$

Therefore, $(v^{(t+1)}, h^{(t+1)})$ is the combined sample at iteration $(t+1)$.

If we must compute the expectation of a function $f(h, v)$, it can be computed as follows:

$$E[f(h, v)] \approx \frac{1}{M} \sum_{t=1}^M f(h^{(t)}, v^{(t)})$$

where M denotes the number of samples generated from the joint probability distribution $P(v, h)$.

Burn-in Period and Generating Samples in Gibbs Sampling

To consider the samples as independent as possible for expectation computation or otherwise based on the joint probability distribution, generally the samples are picked up at an interval of k samples. The larger the value of k the better at removing the auto-correlation among the generated samples. Also, the samples generated at the beginning of the Gibbs sampling are ignored. These ignored samples are said to have been generated in the burn-in period.

The burn-in period uses the Markov Chain to settle down to an equilibrium distribution before we can start drawing samples from it. This is required because we generate the Markov Chain from an arbitrary sample that might be a low-probability zone with respect to the actual distribution, and so we can throw away those unwanted samples. The low-probability samples don't contribute much to the actual expectation, and thus having plenty of them in the sample would obscure the expectation. Once the Markov Chain has run long enough, it will have settled to some high-probability zone, at which point we can start collecting the samples.

Using Gibbs Sampling in Restricted Boltzmann Machines

Block Gibbs sampling can be used to compute the expectations with respect to the joint probability distribution $P(v, h/\theta)$ as mentioned in the equations in (5.3.37) for computing the gradient with respect to the model parameters b , c , and W . Here are the equations from (5.3.37) for easy reference:

$$\begin{cases} \nabla_b(C) = \sum_{t=1}^m v^{(t)} - mE_{P(h,v/\theta)}[v] \\ \nabla_c(C) = \sum_{t=1}^m \hat{h} - mE_{P(h,v/\theta)}[h] \\ \nabla_W(C) = \sum_{t=1}^m v^{(t)} \hat{h}^T - mE_{P(h,v/\theta)}[vh^T] \end{cases}$$

The expectations $E_{P(h,v/\theta)}[v]$, $E_{P(h,v/\theta)}[h]$, and $E_{P(h,v/\theta)}[vh^T]$ all require sampling from the joint probability distribution $P(v, h/\theta)$. Through Block Gibbs sampling, samples (v, h) can be drawn as follows based on their conditional probabilities, where t denotes the iteration number of Gibbs sampling:

$$h^{(t+1)} \sim P(h/v^{(t)}, \theta)$$

$$v^{(t+1)} \sim P(v/h^{(t+1)}, \theta)$$

What makes sampling even easier is the fact that the hidden units' h_j s are independent given the visible unit states, and vice versa:

$$P(h/v) = P(h_1/v)P(h_2/v)..P(h_n/v) = \prod_{j=1}^n P(h_j/v)$$

This allows the individual hidden units' h_j s to be sampled independently in parallel given the values of the visible unit states. The parameter θ has been removed from the preceding notation since θ would remain constant for a step of gradient descent when we perform Gibbs sampling.

Now, each of the hidden unit output states h_j can be either 0 or 1, and its probability of assuming state 1 is given by (5.3.16) as

$$P(h_j = 1/v) = \sigma \left(c_j + \sum_{i=1}^m v_i w_{ij} \right)$$

This probability can be computed based on the current value of $v = v^{(t)}$ and model parameters $c, W \in \theta$. The computed probability $P(h_j = 1/v^{(t)})$ is compared to a random sample u generated from a uniform distribution $U[0, 1]$. If $P(h_j = 1/v^{(t)}) > u$, then the sampled $h_j = 1$, else $h_j = 0$. All such h_j s sampled in this fashion form the combined hidden unit state vector $h^{(t+1)}$.

Similarly, the visible units are independent given the hidden unit states:

$$P(v/h) = P(v_1/h)P(v_2/h)..P(v_n/h) = \prod_{i=1}^m P(v_i/h)$$

Each of the visible units can be sampled independently given $h^{(t+1)}$ to get the combined $v^{(t+1)}$ in the same way as for the hidden units. The required sample thus generated in the $(t+1)$ iteration is given by $(v^{(t+1)}, h^{(t+1)})$.

All the expectations $E_{P(h,v/\theta)}[v]$, $E_{P(h,v/\theta)}[h]$, and $E_{P(h,v/\theta)}[vh^T]$ can be computed by taking the averages of the samples generated through Gibbs sampling. Through Gibbs sampling, if we take N samples after considering burn-in periods and auto-correlation as discussed earlier, the required expectation can be computed as follows:

$$E_{P(h,v/\theta)}[v] \approx \frac{1}{N} \sum_{i=1}^N v^{(i)}$$

$$E_{P(h,v/\theta)}[h] \approx \frac{1}{N} \sum_{i=1}^N h^{(i)}$$

$$E_{P(h,v/\theta)}[vh^T] \approx \frac{1}{N} \sum_{i=1}^N v^{(i)} h^{(i)T}$$

However, doing Gibbs sampling for the joint distribution to generate N samples in each iteration of gradient descent becomes a tedious task and is often impractical. There is an alternate way of approximating these expectations, called *contrastive divergence*, which we will discuss in the next section.

Contrastive Divergence

Performing Gibbs sampling on the joint probability distribution $P(h, v/\theta)$ at each step of gradient descent becomes challenging since Markov Chain Monte Carlo methods such as Gibbs sampling take a long time to converge, which is required in order to produce unbiased samples. These unbiased samples drawn from the joint probability distribution are used to compute the expectations terms $E_{P(h,v/\theta)}[v]$, $E_{P(h,v/\theta)}[h]$, and $E_{P(h,v/\theta)}[vh^T]$, which are nothing but components of the term $E_{P(h,v/\theta)}[\nabla_{\theta}(-E(v, h))]$ in the combined expression for gradients as deduced in (5.3.28).

$$\nabla_{\theta}(C) = \sum_{t=1}^m E_{P(h/v^{(t)}, \theta)}[\nabla_{\theta}(-E(v^{(t)}, h))] - m E_{P(h,v/\theta)}[\nabla_{\theta}(-E(v, h))]$$

The second term in the preceding equation can be rewritten as a summation over the m data points, and hence

$$\nabla_{\theta}(C) = \sum_{t=1}^m E_{P(h/v^{(t)}, \theta)}[\nabla_{\theta}(-E(v^{(t)}, h))] - \sum_{t=1}^m E_{P(h,v/\theta)}[\nabla_{\theta}(-E(v, h))]$$

Contrastive divergence approximates the overall expectation $E_{P(h,v/\theta)}[\nabla_{\theta}(-E(v, h))]$ by a point estimate at a candidate sample (\bar{v}, \bar{h}) obtained by performing Gibbs sampling for only a couple of iterations.

$$E_{P(h,v/\theta)}[\nabla_{\theta}(-E(v, h))] \approx \nabla_{\theta}(-E(\bar{v}, \bar{h}))$$

This approximation is done for every data point $v^{(t)}$, and hence the expression for the overall gradient can be rewritten as follows:

$$\nabla_{\theta}(C) \approx \sum_{t=1}^m E_{P(h/v^{(t)}, \theta)}[\nabla_{\theta}(-E(v^{(t)}, h))] - \sum_{t=1}^m [\nabla_{\theta}(-E(\bar{v}^{(t)}, \bar{h}^{(t)}))]$$

Figure 5-6 below illustrates how Gibbs sampling is performed for each input data point $v^{(t)}$ to get the expectation approximation over the joint probability distribution by a point estimate. The Gibbs sampling starts with $v^{(t)}$ and, based on the conditional probability distribution $P(h/v^{(t)})$, the new hidden state h' is obtained. As discussed earlier, each of the hidden units h_j can be sampled independently and then be combined to form the hidden state vector h' . Then v' is sampled based on the conditional probability distribution $P(v/h')$. This iterative process is generally run for couple of iterations, and the final v and h sampled are taken as the candidate sample (\bar{v}, \bar{h}) .

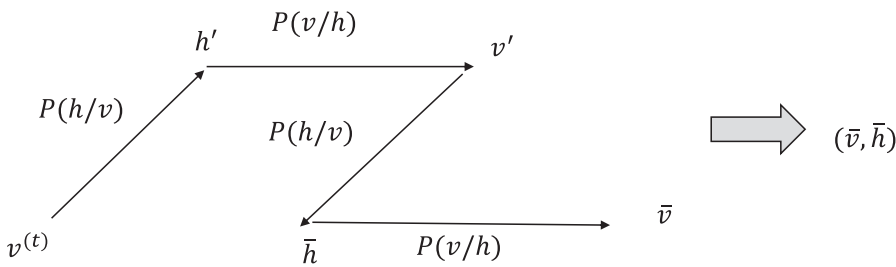

Figure 5-6. Gibbs sampling for two iterations to get one sample for Contrastive Divergence

The contrastive divergence method makes the gradient descent faster since the Gibbs sampling in each step of gradient descent is limited to only a few iterations, mostly one or two per data point.

A Restricted Boltzmann Implementation in TensorFlow

In this section, we will go through the implementation of restricted Boltzmann machines using the MNIST dataset. Here, we try to model the structure of the MNIST images by defining a restricted Boltzmann machine network that consists of the image pixels as the visible units and 500 hidden layers in order to decipher the internal structure of each image. Since the MNIST images are 28×28 in dimension, when flattened as a vector we have 784 visible units. We try to capture the hidden structures properly by training the Boltzmann machines. Images that represent the same digit should have similar hidden states, if not the same, when said hidden states are sampled given the visible representations of the input images. When the visible units are sampled, given their hidden structure, the visible unit values when structured in an image form should correspond to the label of the image. The detailed code is illustrated in Listing 5-3a.

Listing 5-3a. Restricted Boltzmann Machine Implementation with MNIST Dataset

```
##Import the Required libraries
import numpy as np
import pandas as pd
import tensorflow as tf
import matplotlib.pyplot as plt
%matplotlib inline

## Read the MNIST files
from tensorflow.examples.tutorials.mnist import input_data
mnist = input_data.read_data_sets("MNIST_data", one_hot=True)

## Set up the parameters for training

n_visible    = 784
n_hidden     = 500
display_step = 1
num_epochs   = 200
batch_size   = 256
lr           = tf.constant(0.001, tf.float32)
```

```

## Define the tensorflow variables for weights and biases as well as placeholder for input
x = tf.placeholder(tf.float32, [None, n_visible], name="x")
W = tf.Variable(tf.random_normal([n_visible, n_hidden], 0.01), name="W")
b_h = tf.Variable(tf.zeros([1, n_hidden], tf.float32, name="b_h"))
b_v = tf.Variable(tf.zeros([1, n_visible], tf.float32, name="b_v"))

## Converts the probability into discrete binary states; i.e., 0 and 1
def sample(probs):
    return tf.floor(probs + tf.random_uniform(tf.shape(probs), 0, 1))

## Gibbs sampling step
def gibbs_step(x_k):
    h_k = sample(tf.sigmoid(tf.matmul(x_k, W) + b_h))
    x_k = sample(tf.sigmoid(tf.matmul(h_k, tf.transpose(W)) + b_v))
    return x_k

## Run multiple Gibbs sampling steps starting from an initial point
def gibbs_sample(k,x_k):
    for i in range(k):
        x_out = gibbs_step(x_k)
# Returns the Gibbs sample after k iterations
    return x_out

# Contrastive Divergence algorithm
# 1. Through Gibbs sampling locate a new visible state x_sample based on the current visible
state x
# 2. Based on the new x sample a new h as h_sample
x_s = gibbs_sample(2,x)
h_s = sample(tf.sigmoid(tf.matmul(x_s, W) + b_h))

# Sample hidden states based given visible states
h = sample(tf.sigmoid(tf.matmul(x, W) + bh))
# Sample visible states based given hidden states
x_ = sample(tf.sigmoid(tf.matmul(h, tf.transpose(W)) + b_v))

# The weight updated based on gradient descent
size_batch = tf.cast(tf.shape(x)[0], tf.float32)
W_add = tf.multiply(1r/size_batch, tf.subtract(tf.matmul(tf.transpose(x), h), tf.matmul(tf.
transpose(x_s), h_s)))
bv_add = tf.multiply(1r/size_batch, tf.reduce_sum(tf.subtract(x, x_s), 0, True))
bh_add = tf.multiply(1r/size_batch, tf.reduce_sum(tf.subtract(h, h_s), 0, True))
updt = [W.assign_add(W_add), b_v.assign_add(bv_add), b_h.assign_add(bh_add)]

# TensorFlow graph execution

with tf.Session() as sess:
    # Initialize the variables of the Model
    init = tf.global_variables_initializer()
    sess.run(init)

```

```

total_batch = int(mnist.train.num_examples/batch_size)
# Start the training
for epoch in range(num_epochs):
    # Loop over all batches
    for i in range(total_batch):
        batch_xs, batch_ys = mnist.train.next_batch(batch_size)
        # Run the weight update
        batch_xs = (batch_xs > 0)*1
        _ = sess.run([updt], feed_dict={x:batch_xs})
    # Display the running step
    if epoch % display_step == 0:
        print("Epoch:", '%04d' % (epoch+1))

print("RBM training Completed !")

## Generate hidden structure for 1st 20 images in test MNIST

out = sess.run(h,feed_dict={x:(mnist.test.images[:20]> 0)*1})
label = mnist.test.labels[:20]

## Take the hidden representation of any of the test images; i.e., the 3rd record
## The output level of the 3rd record should match the image generated
plt.figure(1)
for k in range(20):
    plt.subplot(4, 5, k+1)
    image = (mnist.test.images[k]> 0)*1
    image = np.reshape(image,(28,28))
    plt.imshow(image,cmap='gray')

plt.figure(2)

for k in range(20):
    plt.subplot(4, 5, k+1)
    image = sess.run(x_,feed_dict={h:np.reshape(out[k],(-1,n_hidden))})
    image = np.reshape(image,(28,28))
    plt.imshow(image,cmap='gray')
    print(np.argmax(label[k]))

sess.close()

--Output --

```

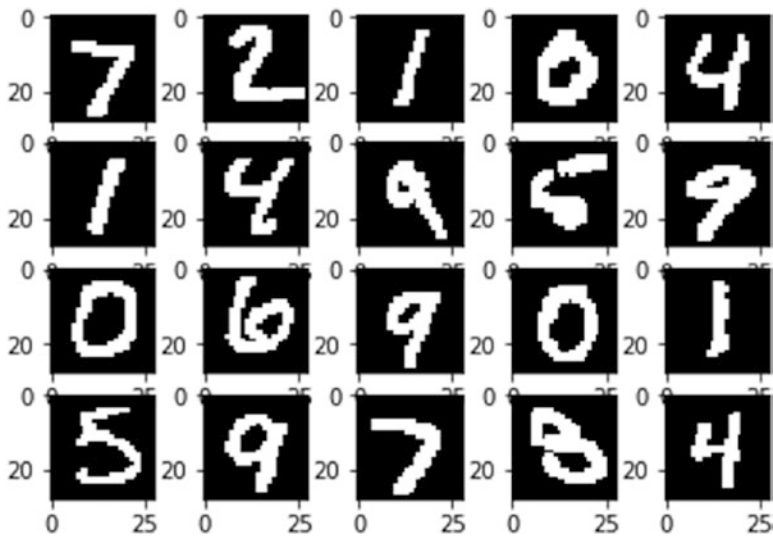

Figure 5-7. Actual test images

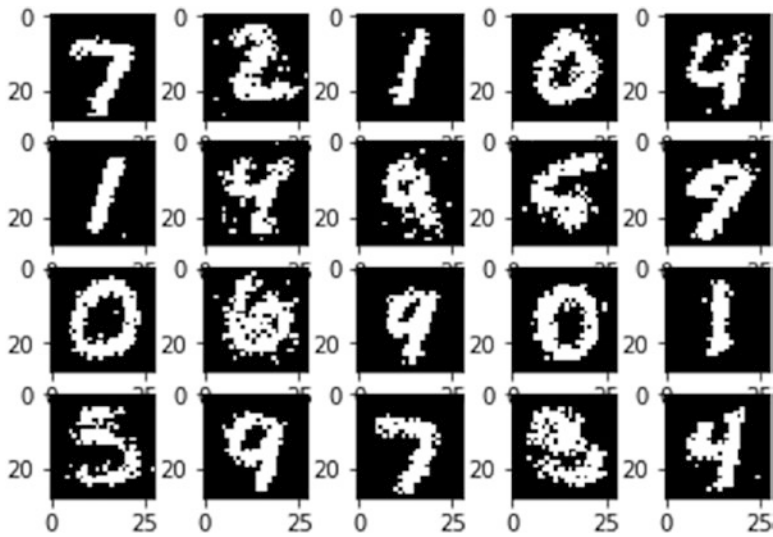

Figure 5-8. Simulated images given the hidden states

We can see from Figure 5-7 and Figure 5-8 that the RBM model did a good job of simulating the input images given their hidden representations. Hence, restricted Boltzmann machines can be used as generative models as well.

Collaborative Filtering Using Restricted Boltzmann Machines

Restricted Boltzmann machines can be used for collaborative filtering in making recommendations. Collaborative filtering is the method of predicting the preference of a user for an item by analyzing the preferences of many users for items. Given a set of items and users along with the ratings the users have provided for a variety of items, the most common method for collaborative filtering is the matrix factorization method, which determines a set of vectors for the items as well as for the users. The rating assigned by a user to an item can then be computed as the dot product of the user vector $u^{(j)}$ with the item vector $v^{(k)}$. Hence, the rating can be expressed as

$$r^{(jk)} = \mathbf{u}^{(j)T} \mathbf{v}^{(k)}$$

where j and k represent the j th user and the k th item respectively. Once the vectors for each item and each user have been learned, the expected ratings a user would assign to a product they haven't rated yet can be found out by the same method. Matrix factorization can be thought of as decomposing a big matrix of ratings into user and item vectors.

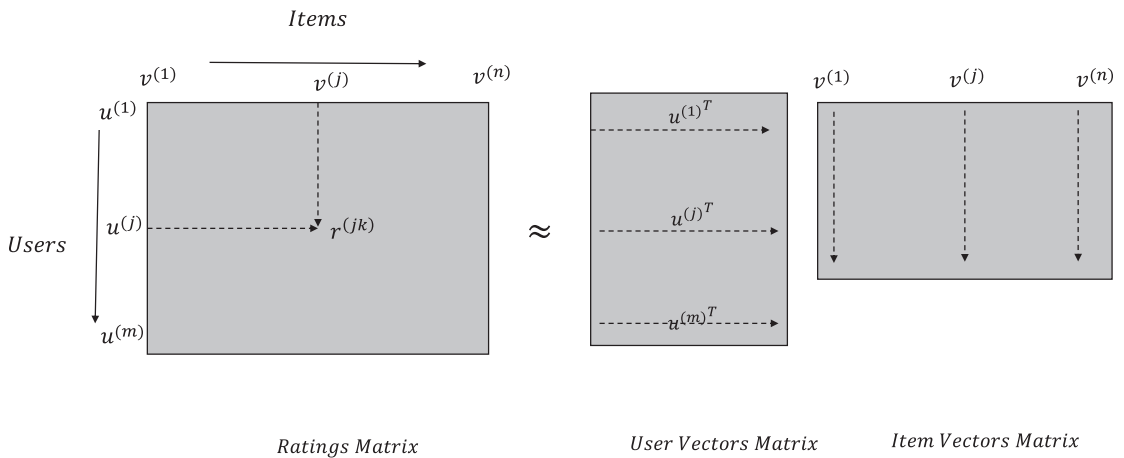

Figure 5-9. Schematic diagram of a matrix factorization method for collaborative filtering

Illustrated in Figure 5-9 is a schematic diagram of a matrix factorization method that decomposes a user item rating matrix into two matrices consisting of user vectors and item vectors. The dimensionality of the user and rating vectors must be equal for their dot product to hold true, which gives an estimate of what rating the user might assign to a particular item. There are several matrix factorization methods, such as singular value decomposition (SVD), non-negative matrix factorization, alternating least squares, and so on. Any of the suitable methods can be used for matrix factorization depending on the use. Generally, SVD requires filling in the missing ratings (where the users have not rated the items) in the matrix, which might be a difficult task, and hence methods such as alternating least squares, which only takes the provided ratings and not the missing values, works well for collaborative filtering.

Now, we will look at a different method of collaborative filtering that uses restricted Boltzmann machines. Restricted Boltzmann machines were used by the winning team in the Netflix Challenge of Collaborative Filtering, and so let's consider the items as movies for this discussion. The visible units for this RBM network would correspond to movie ratings, and instead of being binary, each movie would be a five-way SoftMax unit to account for the five possible ratings from 1 to 5. The number of hidden units can be chosen arbitrarily; we chose d here. There would be several missing values for different movies since all the movies would not be rated by all the users. The way to handle them is to train a separate RBM for each user based on only the movies that user has rated. The weights from the movies to the hidden units would be shared by all users. For instance, let's say *User A* and *User B* rate the same movie; they would use the same weights connecting the movie unit to the hidden units. So, all the RBMs would have the same hidden units, and of course their activation of the hidden units may be very different.

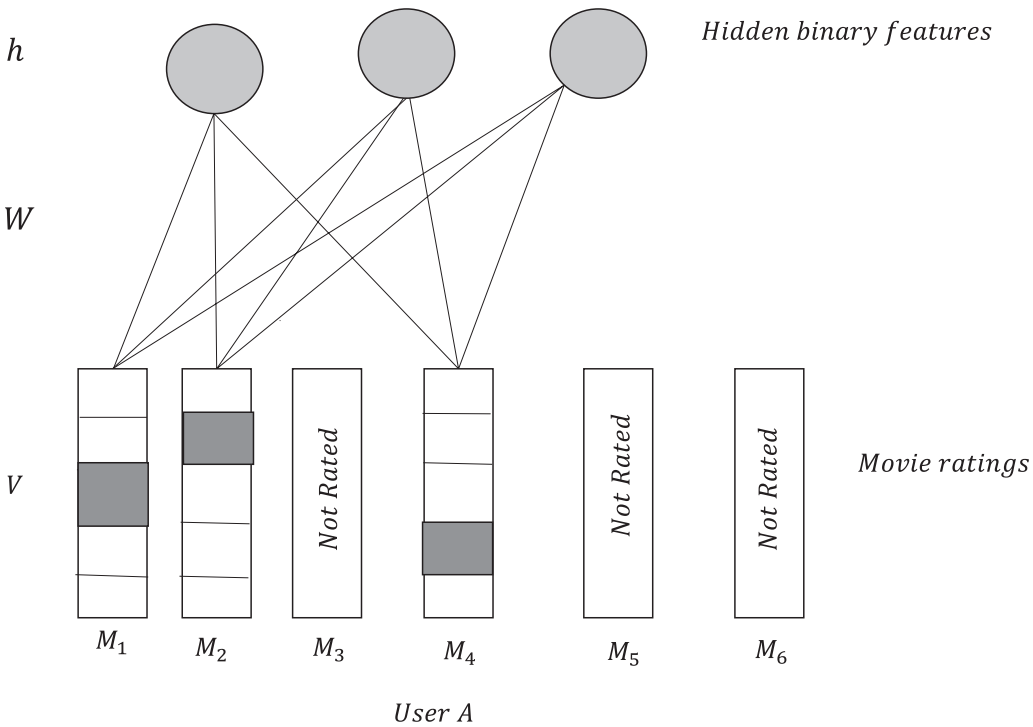

Figure 5-10. Restricted Boltzmann view for User A

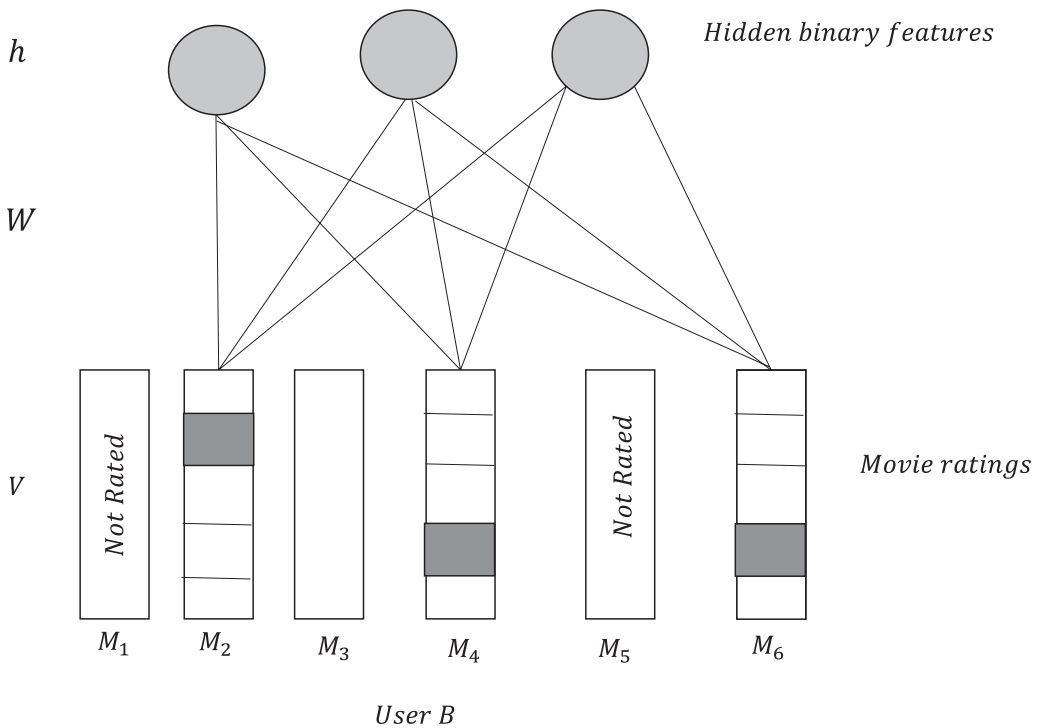

Figure 5-11. Restricted Boltzmann view for User B

As we can see from Figure 5-10 and Figure 5-11, the restricted Boltzmann views for User A and User B are different since they differ in the selection of movies they have rated. However, for the movies they both have rated, the weight connections are the same. This kind of architecture—where each user’s RBM is trained separately while the RBMs share weights for same movies—helps overcome the problem of missing ratings and at the same time allows generalized weights for a movie to hidden layer connection for all the users. From each movie to the hidden unit and vice versa there are actually five connections, one for each of the possible ratings for a movie. However, to keep the representation simple, only one combined connection has been shown in the diagrams. Each of the models can be trained separately through gradient descent using contrastive divergence, and the model weights can be averaged across the different RBMs so that all the RBMs share the same weights.

From 5.3.17, we have for the binary visible unit the following:

$$P(v_i = 1/h) = \sigma \left(b_i + \sum_{j=1}^n h_j w_{ij} \right)$$

Now that the visible units have K possible ratings, the visible units are K dimensional vectors with only one index corresponding to the actual rating set to 1, and the rest all are set to zero. So, the new expression of the probability of a rating over K possible ratings would be given by a SoftMax function. Also, do note that the m in this case is the number of movies a user has watched and would vary for different RBMs for different users. The constant n denotes the number of hidden units in the hidden layer for each RBM.

$$P(v_i^{(k)} = 1/h) = \frac{e^{\left(b_i^{(k)} + \sum_{j=1}^n h_j w_{ij}^{(k)}\right)}}{\sum_{l=1}^K e^{\left(b_l^{(k)} + \sum_{j=1}^n h_j w_{lj}^{(k)}\right)}} \quad (5.4.1)$$

where $w_{ij}^{(k)}$ is the weight connecting the k th rating index for visible unit i to the j th hidden unit and $b_i^{(k)}$ represents the bias at the visible unit i for its k th rating.

The energy of a joint configuration $E(v, h)$ is given by

$$E(v, h) = -\sum_{k=1}^K \sum_{i=1}^m b_i^{(k)} v_i^{(k)} - \sum_{j=1}^n c_j h_j - \sum_{k=1}^K \sum_{j=1}^n \sum_{i=1}^m v_i^{(k)} w_{ij}^{(k)} h_j \quad (5.4.2)$$

So,

$$P(v, h) \propto e^{-E(v, h)} = e^{\sum_{k=1}^K \sum_{i=1}^m b_i^{(k)} v_i^{(k)} + \sum_{j=1}^n c_j h_j + \sum_{k=1}^K \sum_{j=1}^n \sum_{i=1}^m v_i^{(k)} w_{ij}^{(k)} h_j} \quad (5.4.3)$$

The probability of the hidden unit given the input v is

$$P(h_j = 1/v) = \frac{e^{\left(c_j + \sum_{i=1}^m \sum_{k=1}^K v_i^{(k)} w_{ij}^{(k)}\right)}}{1 + e^{\left(c_j + \sum_{i=1}^m \sum_{k=1}^K v_i^{(k)} w_{ij}^{(k)}\right)}} \quad (5.4.4)$$

Now, the obvious question: How do we predict the rating for a movie a user has not seen? As it turns out, the computation for this is not that involved and can be computed in linear time. The most informative way of making that decision is to condition the probability of the user, provided rating r to a movie q is conditioned on the movie ratings the user has already provided. Let the movie ratings the user has already provided be denoted by V . So, we need to compute the probability $P(v_q^{(k)}/V)$ as follows:

$$P(v_q^{(k)}/V) = \sum_h P(v_q^{(k)}, h/V) = \frac{\sum_h P(v_q^{(k)}, h, V)}{P(V)} \quad (5.4.5)$$

Since $P(V)$ is fixed for all movie ratings k , from (5.4.5) we have

$$\begin{aligned} P(v_q^{(k)}/V) &\propto \sum_h P(v_q^{(k)}, h, V) \\ &\propto \sum_h e^{-E(v_q^{(k)}, h, V)} \end{aligned} \quad (5.4.6)$$

This is a three-way energy configuration and can be computed easily by adding the contribution of $v_q^{(k)}$ in (5.4.2), as shown here:

$$E(v_q^{(k)}, V, h) = - \sum_{k=1}^K \sum_{i=1}^m b_i^{(k)} v_i^{(k)} - \sum_{j=1}^n c_j h_j - \sum_{k=1}^K \sum_{j=1}^n \sum_{i=1}^m v_i^{(k)} w_{ij}^{(k)} h_j - \sum_{j=1}^n v_s^{(k)} w_{sj}^{(k)} h_j - v_s^{(k)} b^{(k)} \quad (5.4.7)$$

Substituting $v_q^{(k)} = 1$ in (5.4.7), one can find the value of $E(v_q^{(k)} = 1, V, h)$, which is proportional to

$$P(v_q^{(k)} = 1, V, h)$$

For all K values of rating k the preceding quantity $E(v_q^{(k)} = 1, V, h)$ needs to be computed and then normalized to form probabilities. One can then either take the value of k for which the probability is maximum or compute the expected value of k from the derived probabilities, as shown here:

$$\hat{k} = \underbrace{\operatorname{argmax}}_k P(v_q^{(k)} = 1 / V)$$

$$\hat{k} = \sum_{k=1}^5 k \times P(v_q^{(k)} = 1 / V)$$

The expectation way of deriving the rating turns out to give better predictions than a hard assignment of a rating based on the maximum probability.

Also, one simple way to derive the probability of the rating k for a specific unrated movie q by a user with rating matrix V is to first sample the hidden states h given the visible ratings input V ; i.e., draw $h \sim P(h/V)$. The hidden units are common to all and hence carry information about patterns for all movies. From the sampled hidden units we try to sample the value of $v_q^{(k)}$; i.e., draw $v_q^{(k)} \sim P(v_q^{(k)}/h)$. This back-to-back sampling, first from $V \rightarrow h$ and then from $h \rightarrow v_q^{(k)}$, is equivalent to sampling $v_q^{(k)} \sim P(v_q^{(k)}/V)$. I hope this helps in providing an easier interpretation.

Deep Belief Networks (DBNs)

Deep belief networks are based on the restricted Boltzmann machine but, unlike an RBN, a DBN has multiple hidden layers. The weights in each hidden layer K are trained by keeping all the weights in the prior $(K-1)$ layers constant. The activities of the hidden units in the $(K-1)$ layer are taken as input for the K th layer. At any particular time during training two layers are involved in learning the weight connections between them. The learning algorithm is the same as that of restricted Boltzmann machines. Illustrated in Figure 5-12 is a high-level schematic diagram for a deep belief network.

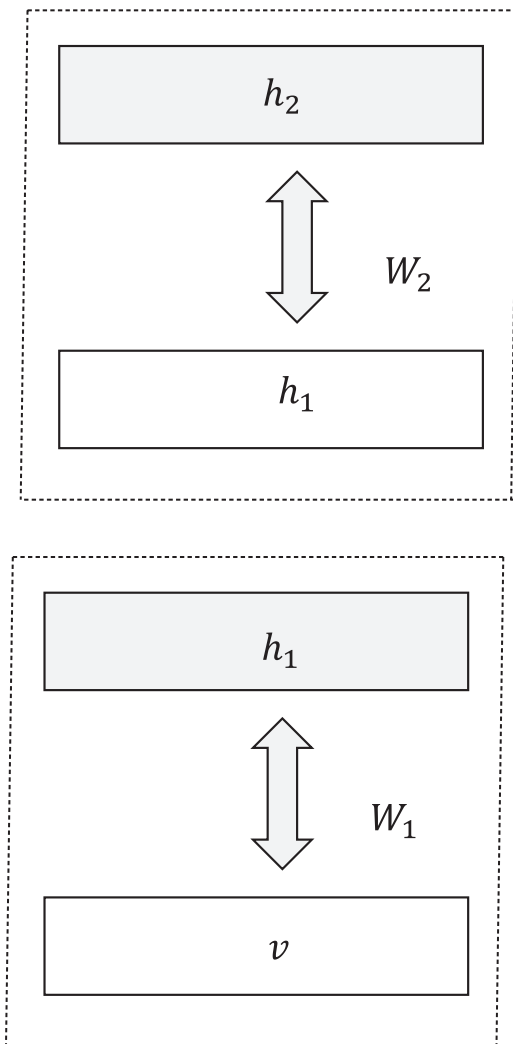

Figure 5-12. Deep belief network using RBMs

Like RBM, in DBN each layer can be trained by gradient descent using contrastive divergence. The DBN learning algorithm is used to learn the initial weights of a deep network being used for supervised learning so that the network has a good set of initial weights to start with. Once the pre-training is done for the deep belief network, we can add an output layer to the DBN based on the supervised problem at hand. Let's say we want to train a model to perform classification on the MNIST dataset. In that case, we would have to append a ten-class SoftMax layer. We can then fine-tune the model by using backpropagation of error. Since the model already has an initial set of weights from unsupervised DBN learning, the model would have a good chance of converging faster when backpropagation is invoked.

Whenever we have sigmoid units in a network, if the network weights are not initialized properly there is a high chance that one might have a vanishing-gradient problem. This is because the output of sigmoid units are linear within a small range, after which the output saturates, leading to near-zero gradients. Since the backpropagation is essentially a chain rule of derivatives, the gradient of the cost function with respect to any weight would have sigmoid gradients from the layers prior to it from a backpropagation order. So, if few

of the gradients in the sigmoid layers are operating in the saturated regions and producing gradients close to zero, the latter layers, gradients of the cost function with respect to the weights, would be close to zero, and there is a high chance that the learning would stop. When the weights are not properly initialized, there is a high chance that the network sigmoid units could go into the unsaturated region and lead to near-zero gradients in the sigmoid units. However, when the network weights are initialized by DBN learning, there is less of a chance of the sigmoid units' operating in the saturated zone. This is because the network has learned something about the data while it was pre-training, and there is a smaller chance that the sigmoid units will operate in saturated zones. Such problems with the activation unit saturating are not present for ReLU activation functions since they have a constant gradient of 1 for input values greater than zero.

We now look at an implementation of DBN pre-training of weights followed by the training of a classification network by appending the output layer to the hidden layer of the RBM. In Listing 5-3a we implemented RBM, wherein we learned the weights of the visible-to-hidden connections, assuming all the units are sigmoid. To that RBM we are going to stack the output layer of ten classes for the MNIST dataset and train the classification model using the weights from the visible-to-hidden units learned as the initial weights for the classification network. Of course, we would have a new set of weights corresponding to the connection of the hidden layer to the output layer. See the detailed implementation in Listing 5-3b.

Listing 5-3b. Basic Implementation of DBN

```
##Import the Required libraries
import numpy as np
import pandas as pd
import tensorflow as tf
import matplotlib.pyplot as plt
%matplotlib inline

## Read the MNIST files
from tensorflow.examples.tutorials.mnist import input_data
mnist = input_data.read_data_sets("MNIST_data", one_hot=True)

## Set up the parameters for training

n_visible      = 784
n_hidden       = 500
display_step   = 1
num_epochs     = 200
batch_size     = 256
lr             = tf.constant(0.001, tf.float32)
learning_rate_train = tf.constant(0.01, tf.float32)
n_classes     = 10
training_iters = 200
## Define the tensorflow variables for weights and biases as well as placeholder for input
x = tf.placeholder(tf.float32, [None, n_visible], name="x")
y = tf.placeholder(tf.float32, [None,10], name="y")

W = tf.Variable(tf.random_normal([n_visible, n_hidden], 0.01), name="W")
b_h = tf.Variable(tf.zeros([1, n_hidden], tf.float32, name="b_h"))
b_v = tf.Variable(tf.zeros([1, n_visible], tf.float32, name="b_v"))
W_f = tf.Variable(tf.random_normal([n_hidden,n_classes], 0.01), name="W_f")
b_f = tf.Variable(tf.zeros([1, n_classes], tf.float32, name="b_f"))
## Converts the probability into discrete binary states i.e. 0 and 1
def sample(probs):
```

```

    return tf.floor(probs + tf.random_uniform(tf.shape(probs), 0, 1))

## Gibbs sampling step
def gibbs_step(x_k):
    h_k = sample(tf.sigmoid(tf.matmul(x_k, W) + b_h))
    x_k = sample(tf.sigmoid(tf.matmul(h_k, tf.transpose(W)) + b_v))
    return x_k

## Run multiple Gibbs Sampling steps starting from an initial point
def gibbs_sample(k,x_k):
    for i in range(k):
        x_out = gibbs_step(x_k)
# Returns the gibbs sample after k iterations
    return x_out

# Contrastive Divergence algorithm
# 1. Through Gibbs sampling locate a new visible state x_sample based on the current visible
state x
# 2. Based on the new x sample a new h as h_sample
x_s = gibbs_sample(2,x)
h_s = sample(tf.sigmoid(tf.matmul(x_s, W) + b_h))

# Sample hidden states based given visible states
h = sample(tf.sigmoid(tf.matmul(x, W) + b_h))
# Sample visible states based given hidden states
x_ = sample(tf.sigmoid(tf.matmul(h, tf.transpose(W)) + b_v))

# The weight updated based on gradient descent
size_batch = tf.cast(tf.shape(x)[0], tf.float32)
W_add = tf.multiply(lr/size_batch, tf.subtract(tf.matmul(tf.transpose(x), h), tf.matmul(tf.
transpose(x_s), h_s)))
bv_add = tf.multiply(lr/size_batch, tf.reduce_sum(tf.subtract(x, x_s), 0, True))
bh_add = tf.multiply(lr/size_batch, tf.reduce_sum(tf.subtract(h, h_s), 0, True))
updt = [W.assign_add(W_add), b_v.assign_add(bv_add), b_h.assign_add(bh_add)]
#####
## Ops for the Classification Network
#####
h_out = tf.sigmoid(tf.matmul(x, W) + b_h)
logits = tf.matmul(h_out,W_f) + b_f
prob = tf.nn.softmax(logits)
cost = tf.reduce_mean(tf.nn.softmax_cross_entropy_with_logits(logits=logits, labels=y))
optimizer = tf.train.AdamOptimizer(learning_rate=learning_rate_train).minimize(cost)
correct_pred = tf.equal(tf.argmax(logits,1), tf.argmax(y, 1))
accuracy = tf.reduce_mean(tf.cast(correct_pred, tf.float32))

## Ops for the hidden unit activation

# TensorFlow graph execution

with tf.Session() as sess:
    # Initialize the variables of the Model
    init = tf.global_variables_initializer()

```

```

sess.run(init)

total_batch = int(mnist.train.num_examples/batch_size)
# Start the training
for epoch in range(num_epochs):
    # Loop over all batches
    for i in range(total_batch):
        batch_xs, batch_ys = mnist.train.next_batch(batch_size)
        # Run the weight update
        batch_xs = (batch_xs > 0)*1
        _ = sess.run([updt], feed_dict={x:batch_xs})

    # Display the running step
    if epoch % display_step == 0:
        print("Epoch:", '%04d' % (epoch+1))

print("RBM training Completed !")

out = sess.run(h,feed_dict={x:(mnist.test.images[:20]> 0)*1})
label = mnist.test.labels[:20]

plt.figure(1)
for k in range(20):
    plt.subplot(4, 5, k+1)
    image = (mnist.test.images[k]> 0)*1
    image = np.reshape(image,(28,28))
    plt.imshow(image,cmap='gray')

plt.figure(2)

for k in range(20):
    plt.subplot(4, 5, k+1)
    image = sess.run(x_,feed_dict={h:np.reshape(out[k],(-1,n_hidden))})
    image = np.reshape(image,(28,28))
    plt.imshow(image,cmap='gray')
    print(np.argmax(label[k]))
#####
### Invoke the Classification Network training now
#####
for i in xrange(training_iters):
    batch_x, batch_y = mnist.train.next_batch(batch_size)
    # Run optimization op (backprop)
    sess.run(optimizer, feed_dict={x: batch_x, y: batch_y})
    if i % 10 == 0:
        # Calculate batch loss and accuracy
        loss, acc = sess.run([cost, accuracy], feed_dict={x: batch_x,
                                                         y: batch_y})
        print "Iter " + str(i) + ", Minibatch Loss= " + \
            "{:.6f}".format(loss) + ", Training Accuracy= " + \
            "{:.5f}".format(acc)

```



```

print "Optimization Finished!"

# Calculate accuracy for 256 mnist test images
print "Testing Accuracy:", \
    sess.run(accuracy, feed_dict={x: mnist.test.images[:256],
                                   y: mnist.test.labels[:256]})

sess.close()

```

--output--

```

Iter 0, Minibatch Loss= 11.230852, Training Accuracy= 0.06641
Iter 10, Minibatch Loss= 2.809783, Training Accuracy= 0.60938
Iter 20, Minibatch Loss= 1.450730, Training Accuracy= 0.75000
Iter 30, Minibatch Loss= 0.798674, Training Accuracy= 0.83594
Iter 40, Minibatch Loss= 0.755065, Training Accuracy= 0.87891
Iter 50, Minibatch Loss= 0.946870, Training Accuracy= 0.82812
Iter 60, Minibatch Loss= 0.768834, Training Accuracy= 0.89062
Iter 70, Minibatch Loss= 0.445099, Training Accuracy= 0.92188
Iter 80, Minibatch Loss= 0.390940, Training Accuracy= 0.89062
Iter 90, Minibatch Loss= 0.630558, Training Accuracy= 0.90234
Iter 100, Minibatch Loss= 0.633123, Training Accuracy= 0.89844
Iter 110, Minibatch Loss= 0.449092, Training Accuracy= 0.92969
Iter 120, Minibatch Loss= 0.383161, Training Accuracy= 0.91016
Iter 130, Minibatch Loss= 0.362906, Training Accuracy= 0.91406
Iter 140, Minibatch Loss= 0.372900, Training Accuracy= 0.92969
Iter 150, Minibatch Loss= 0.324498, Training Accuracy= 0.91797
Iter 160, Minibatch Loss= 0.349533, Training Accuracy= 0.93750
Iter 170, Minibatch Loss= 0.398226, Training Accuracy= 0.90625
Iter 180, Minibatch Loss= 0.323373, Training Accuracy= 0.93750
Iter 190, Minibatch Loss= 0.555020, Training Accuracy= 0.91797
Optimization Finished!
Testing Accuracy: 0.945312

```

As we can see from the preceding output, with the pre-trained weights from RBM used as initial weights for the classification network we can get good accuracy of around 95 percent on the MNIST test dataset by just running it for 200 batches. This is impressive given that the network does not have any convolutional layers.

Auto-encoders

Auto-encoders are unsupervised artificial neural networks that are used to generate a meaningful internal representation of the input data. The auto-encoder network generally consists of three layers—the input layer, the hidden layer, and the output layer. The input layer and hidden layer combination acts as the encoder while the hidden layer and output layer combination acts as the decoder. The encoder tries to represent the input as a meaningful representation at the hidden layer while the decoder reconstructs the input back into its original dimension at the output layer. Typically, some cost function between the reconstructed input and the original input is minimized as part of the training process.

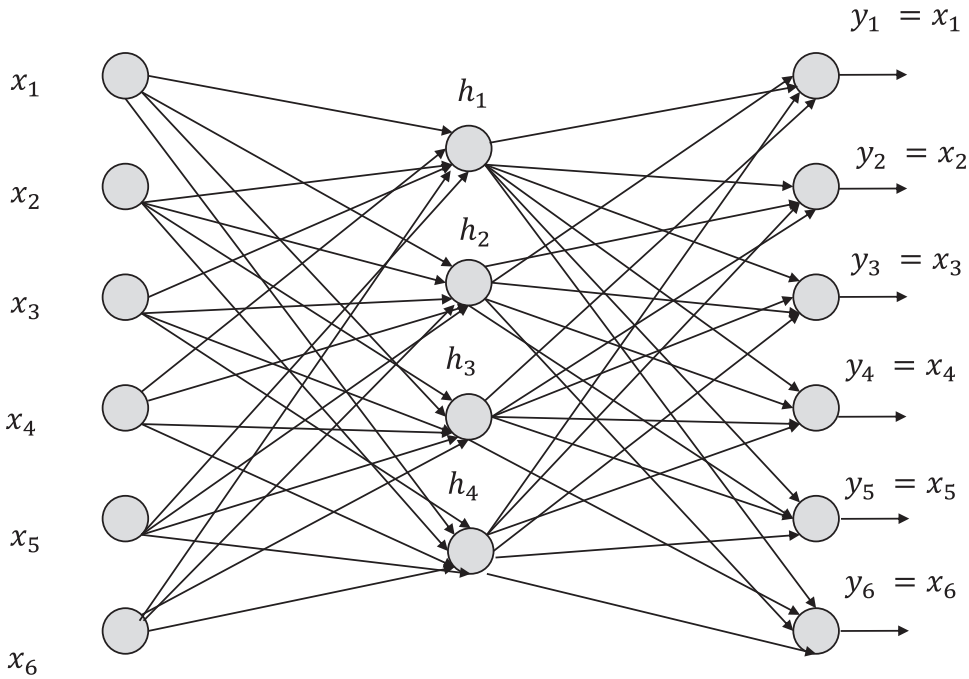

Figure 5-13. Architecture of a basic auto-encoder

Figure 5-13 represents a basic auto-encoder with one hidden layer and the input and the output layers. The input $x = [x_1 x_2 x_3 \dots x_6]^T \in \mathbb{R}^{6 \times 1}$ while the hidden layer $h = [h_1 h_2 h_3 h_4]^T \in \mathbb{R}^{4 \times 1}$. The output y is chosen to be equal to x so that the error between the reconstructed input \hat{y} can be minimized so as to get a meaningful representation of the input in the hidden layer. For generality purposes, let's take

$$x = [x_1 x_2 x_3 \dots x_n]^T \in \mathbb{R}^{n \times 1}$$

$$h = [h_1 h_2 h_3 \dots h_d]^T \in \mathbb{R}^{d \times 1}$$

$$y = x = [y_1 y_2 y_3 \dots y_n]^T \in \mathbb{R}^{n \times 1}$$

Let the weights from x to h be represented by the weight matrix $W \in \mathbb{R}^{d \times n}$ and the biases at the hidden unit be represented by $b = [b_1 b_2 b_3 \dots b_d]^T \in \mathbb{R}^{d \times 1}$.

Similarly, let the weights from h to y be represented by the weight matrix $W' \in \mathbb{R}^{n \times d}$ and the biases at the output units be represented as $b' = [b'_1 b'_2 b'_3 \dots b'_n]^T \in \mathbb{R}^{n \times 1}$.

The output of the hidden unit can be expressed as

$$h = f_1(Wx + b)$$

where f_1 is the element-wise activation function at the hidden layer. The activation function can be linear, ReLU, sigmoid, and so forth depending on its use.

Similarly, the output of the output layer can be expressed as

$$\hat{y} = f_2(W'h + b')$$

If the input features are of a continuous nature, one can minimize a least square-based cost function as follows to derive the model weights and biases based on the training data:

$$C = \sum_{k=1}^m \|\hat{y}^{(k)} - y^{(k)}\|_2^2 = \sum_{k=1}^m \|\hat{y}^{(k)} - x^{(k)}\|_2^2$$

where $\|\hat{y}^{(k)} - x^{(k)}\|_2^2$ is the Euclidean or the L^2 norm distance between the reconstructed output vector and the original input vector and m is the number of data points on which the model is trained on.

If we represent all the parameters of the model by the vector $\theta = [W; b; W'; b']$ then the cost function C can be minimized with respect to all the parameters of the model θ to derive the model

$$\hat{\theta} = \underbrace{\text{Arg Min}}_{\theta} C(\theta) = \underbrace{\text{Arg Min}}_{\theta} \sum_{k=1}^m \|\hat{y}^{(k)} - x^{(k)}\|_2^2$$

The learning rule of the model as per gradient descent is

$$\theta^{(t+1)} = \theta^{(t)} - \epsilon \nabla_{\theta} C(\theta^{(t)})$$

where ϵ is the learning rate, t represents the iteration number, and $\nabla_{\theta} C(\theta^{(t)})$ is the gradient of the cost function with respect to θ at $\theta = \theta^{(t)}$.

Now, let us consider several cases as follows:

- When the dimension of the hidden layer is less than that of the input layer, i.e., ($d < n$) where d is the hidden layer and n is the dimension of input layer, then the auto-encoder works as a data-compression network that projects the data from a high-dimension space to a lower-dimension space given by the hidden layer. This is a lossy data-compression technique. It can also be used for noise reduction in the input signal.
- When ($d < n$) and all the activation functions are linear then the network learns to do a linear PCA (principal component analysis).
- When ($d \geq n$) and the activation functions are linear then the network may learn an identity function, which might not be of any use. However, if the cost function is regularized to produce a sparse hidden representation then the network may still learn an interesting representation of the data.
- Complex non-linear representations of input data can be learned by having more hidden layers in the network and by making the activation functions non-linear. A schematic diagram of such a model is represented in Figure 5-14. When taking multiple hidden layers, it is a must that one takes non-linear activation functions to learn non-linear representations of data since several layers of linear activations are equivalent to a single linear activation layer.

Feature Learning Through Auto-encoders for Supervised Learning

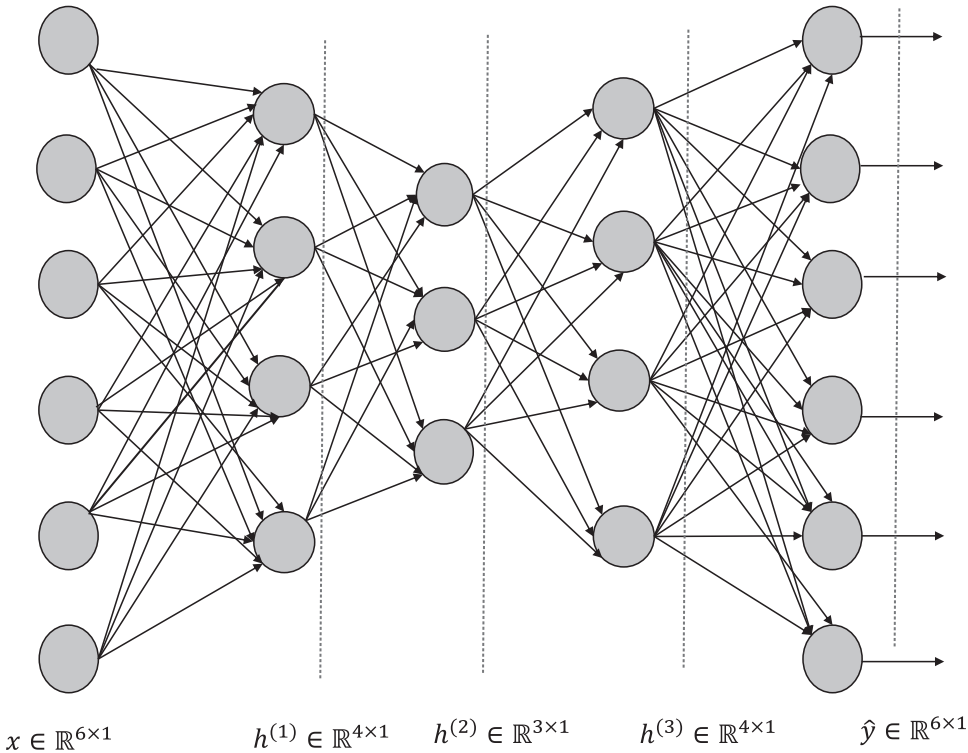

Figure 5-14. Auto-encoder with multiple hidden layers

When we deal with multiple hidden layers, as shown in Figure 5-14, and have a non-linear activation function in the neural units, then the hidden layers learn non-linear relations between the variables of the input data. If we are working on a classification-related problem of two classes where the input data is represented by $x \in \mathbb{R}^{6 \times 1}$ we can learn interesting non-linear features by training the auto-encoder as in Figure 5-14 and then using the output of the second hidden layer vector $h^{(2)} \in \mathbb{R}^{3 \times 1}$. This new non-linear feature representation given by $h^{(2)}$ can be used as the input to a classification model, as shown in Figure 5-15. When the hidden layer whose output we are interested in has a dimensionality less than that of the input, it is equivalent to the non-linear version of principal component analysis wherein we are just consuming the important non-linear features and discarding the rest as noise.

$$h^{(2)} \in \mathbb{R}^{3 \times 1}$$

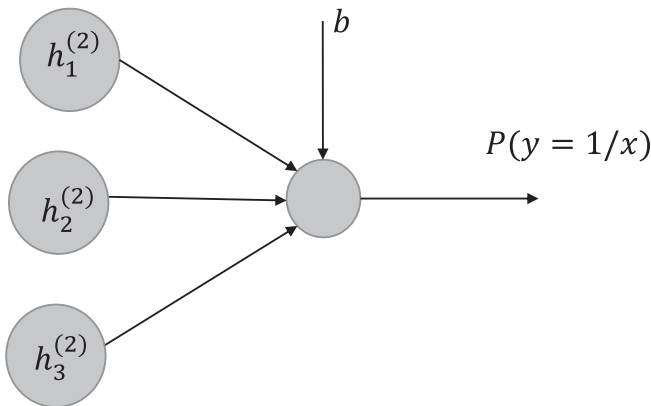

Figure 5-15. Classifier with features learned from auto-encoder

The overall network can be combined into a single network for class-prediction purpose at test time by combining the two networks as shown in Figure 5-16. From the auto-encoder, only the part of the network up to the second hidden layer that is producing output $h^{(2)}$ needs to be considered, and then it needs to be combined with the classification network as in Figure 5-15.

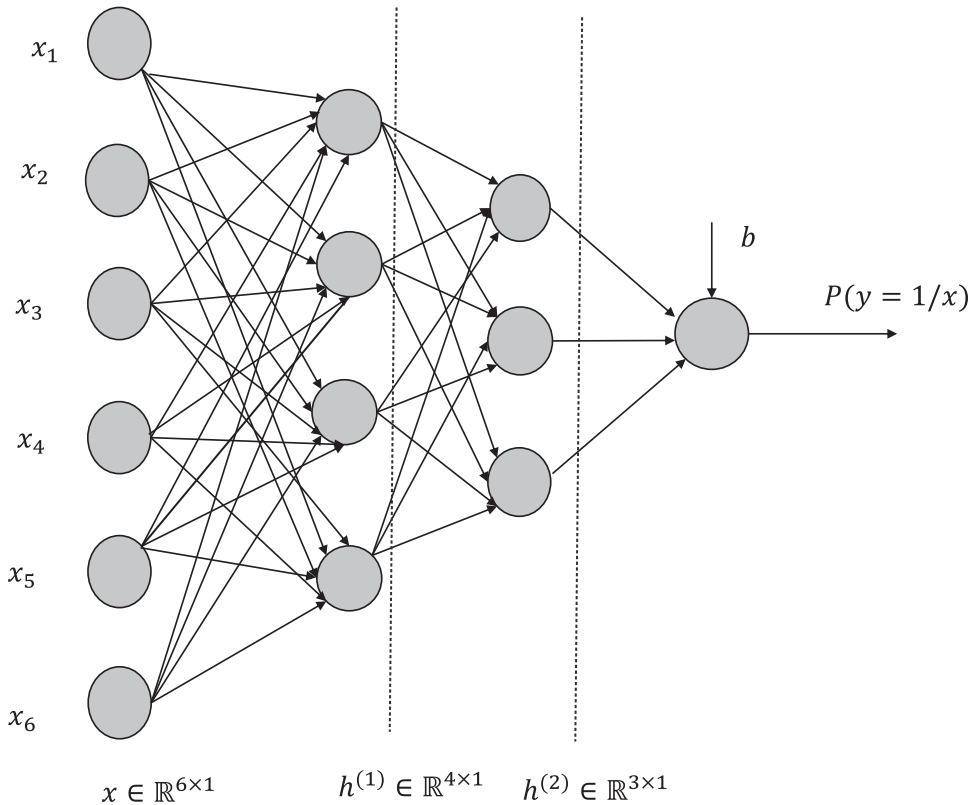

Figure 5-16. Combined classification network for prediction of classes

One might ask the obvious question: Why would linear PCA not suffice for the task the auto-encoder is performing in this example? Linear PCA or Principal Component Analysis only takes care of the capturing the linear relationship between input variables and tries to decompose the input variables into components that are not linearly dependent on each other. These components are called *principal components* and are uncorrelated with each other, unlike the original input variables. However, the input variables are not always going to be related in a linear fashion that leads to linear correlation. Input variables might be correlated in much more complex, non-linear ways, and such non-linear structures within the data can be captured only through non-linear hidden units in the auto-encoders.

Kullback-Leibler (KL) Divergence

The KL divergence measures the disparity or divergence between two random Bernoulli variables. If two random Bernoulli variables X and Y have means of ρ_1 and ρ_2 respectively, then the KL divergence between the variables X and Y is given by

$$KL(\rho_1 \parallel \rho_2) = \rho_1 \log\left(\frac{\rho_1}{\rho_2}\right) + (1 - \rho_1) \log\left(\frac{1 - \rho_1}{1 - \rho_2}\right)$$

From the preceding expression, we can see that the KL divergence is 0 when $\rho_1 = \rho_2$; i.e., when both distributions are identical. When $\rho_1 \neq \rho_2$, the KL divergence increases monotonically with the difference of the means. If ρ_1 is chosen to be 0.2 then the KL divergence versus the ρ_2 plot is as expressed in Figure 5-17.

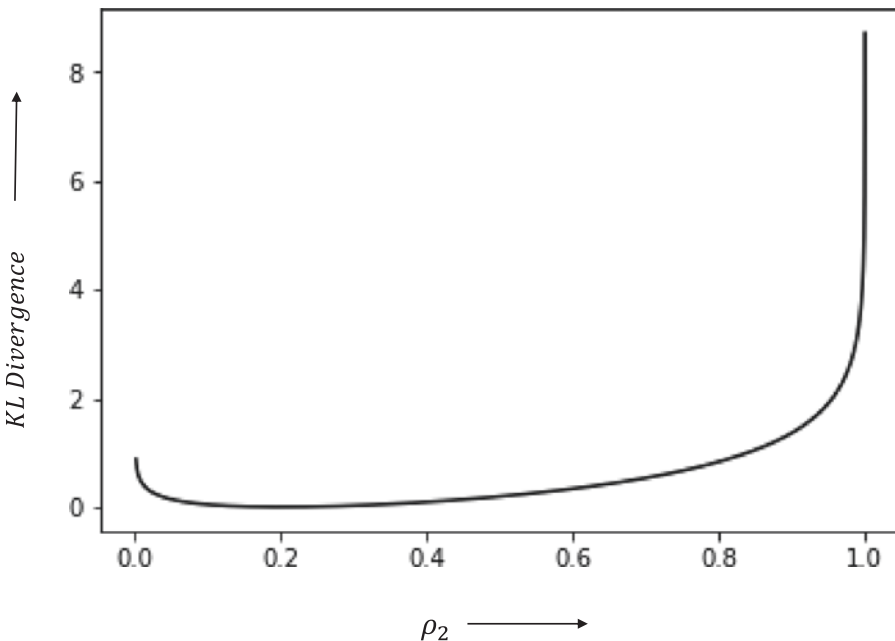

Figure 5-17. KL divergence plot for mean $\rho_1 = 0.2$

As we can see, the KL divergence is at its minimum at $\rho_2 = \rho_1 = 0.2$ and increases monotonically on either side of $\rho_2 = 0.2$. We will be using KL divergence to introduce sparsity in the hidden layer for sparse auto-encoders in the next section.

Sparse Auto-encoders

The purpose of auto-encoders, as we discussed earlier, is to learn interesting hidden structures of the input data or, more specifically, to learn interesting relations among the different variables in the input. The most common way to derive these hidden structures is to make the hidden layer dimension smaller than the input data dimension so that the auto-encoder is forced to learn a compressed representation of the input data. This compressed representation is forced to reconstruct the original data, and hence the compressed representation should have enough information to capture the input sufficiently well. This compressed representation will only be able to capture the input data efficiently if there is redundancy in the data in the form of correlation and other non-linear associations between the input variables. If the input features are relatively independent, then such compression would not be able to represent the original data well. So, for the auto-encoder to give an interesting low-dimensional representation of the input data, the data should have enough structure in it in the form of correlation and other non-linear associations between input variables.

One thing that we touched upon earlier is that when the number of hidden layer units is larger than the dimensionality of the input, there is a high possibility that the auto-encoder will learn identity transform after setting the weights corresponding to the extra hidden layers to zero. In fact, when the number of input and hidden layers are the same, the optimal solution for the weight matrix connecting the input to the hidden layer is the identity matrix. However, even when the number of hidden units is larger than the dimensionality of the input, the auto-encoder can still learn interesting structures within the data, provided some constraints. One such constraint is to restrict the hidden layer output to be sparse so that those activations in the hidden layer units on average are close to zero. We can achieve this sparsity by adding a regularization term to the cost function based on KL divergence. Here, the ρ_1 will be very close to zero, and the average activation in the hidden unit over all training samples would act as the ρ_2 for that hidden unit. Generally, ρ_1 is selected to be very small, to the order of 0.04, and hence if the average activation in each of the hidden units is not close to 0.04 then the cost function would be penalized.

Let $h \in \mathbb{R}^{d-1}$ be the hidden layer sigmoid activations of the input $x \in \mathbb{R}^{n-1}$ where $d > n$. Further, let the weights connecting the inputs to the hidden layer be given by $W \in \mathbb{R}^{d \times n}$ and the weights connecting the hidden layer to the output layer be given by $W' \in \mathbb{R}^{n \times d}$. If the bias vectors at the hidden and output layers are given by b and b' respectively, then the following relationship holds true:

$$h^{(k)} = \sigma(Wx^{(k)} + b)$$

$$\hat{y}^{(k)} = f(W'h^{(k)} + b')$$

where $h^{(k)}$ and $y^{(k)}$ are the hidden layer output vector and the reconstructed input vector for the k th input training data point. The cost function to be minimized with respect to the parameters of the model (i.e., W, W', b, b') is given by

$$C = \sum_{k=1}^m \left\| \hat{y}^{(k)} - x^{(k)} \right\|_2^2 + \lambda \sum_{j=1}^d KL(\rho \| \hat{\rho}_j)$$

where $\hat{\rho}_j$ is the average activation in the j th unit of the hidden layer over all the training samples and can be represented as follows. Also, $h_j^{(k)}$ represents the hidden layer activation at unit j for the k th training sample.

$$\hat{\rho}_j = \frac{1}{m} \sum_{k=1}^m h_j^{(k)}$$

$$KL(\rho \parallel \hat{\rho}_j) = \rho \log \left(\frac{\rho}{\hat{\rho}_j} \right) + (1 - \rho) \log \left(\frac{1 - \rho}{1 - \hat{\rho}_j} \right)$$

Generally, ρ is selected as 0.04 to 0.05 so that the model learns to produce average hidden layer unit activations very close to 0.04, and in the process the model learns sparse representation of the input data in the hidden layer.

Sparse auto-encoders are useful in computer vision to learn low-level features that represent the different kinds of edges at different locations and orientations within the natural images. The hidden layer output gives the weight of each of these low-level features, which can be combined to reconstruct the image. If 10×10 images are processed as 100-dimensional input, and if there are 200 hidden units, then the weights connecting input to hidden units—i.e., W or hidden units to the output reconstruction layer W' —would comprise 200 images of size 100 (10×10). These images can be displayed to see the nature of the features they represent. Sparse encoding works well when supplemented with PCA whitening, which we will discuss briefly later in this chapter.

Sparse Auto-Encoder Implementation in TensorFlow

In this section, we will implement a sparse auto-encoder that has more hidden units than the input dimensionality. The dataset for this implementation is the MNIST dataset. Sparsity has been introduced in the implemented network through KL divergence. Also, the weights of the encoder and decoder are used for L2 regularization to ensure that in the pursuit of sparsity these weights don't adjust themselves in undesired ways. The auto-encoder and decoder weights represent over-represented basis, and each of these basis tries to learn some low-level feature representations of the images, as discussed earlier. The encoder and the decoder are taken to be the same. These weights that make up the low-level feature images have been displayed to highlight what they represent. The detailed implementation has been outlined in Listing 5-4.

Listing 5-4.

```
## Import the required libraries and data

import tensorflow as tf
import numpy as np
import matplotlib.pyplot as plt
%matplotlib inline
import time
# Import MNIST data
from tensorflow.examples.tutorials.mnist import input_data
mnist = input_data.read_data_sets("MNIST_data", one_hot=True)

# Parameters for training the Network
learning_rate = 0.001
```



```

training_epochs = 200
batch_size = 1000
display_step = 1
examples_to_show = 10

# Network Parameters
# Hidden units are more than the input dimensionality since the intention
# is to learn sparse representation of hidden units
n_hidden_1 = 32*32
n_input = 784 # MNIST data input (img shape: 28*28)

X = tf.placeholder("float", [None, n_input])

weights = {
    'encoder_h1': tf.Variable(tf.random_normal([n_input, n_hidden_1])),
}
biases = {
    'encoder_b1': tf.Variable(tf.random_normal([n_hidden_1])),
    'decoder_b1': tf.Variable(tf.random_normal([n_input])),
}

# Building the encoder
def encoder(x):
    # Encoder Hidden layer with sigmoid activation #1
    layer_1 = tf.nn.sigmoid(tf.add(tf.matmul(x, weights['encoder_h1']),
                                   biases['encoder_b1']))

    return layer_1

# Building the decoder
def decoder(x):
    layer_1 = tf.nn.sigmoid(tf.add(tf.matmul(x, tf.transpose(weights['decoder_h1'])),
                                   biases['decoder_b1']))

    return layer_1

## Define the log-based function to be used in computing the KL Divergence
def log_func(x1, x2):
    return tf.multiply(x1, tf.log(tf.div(x1,x2)))

def KL_Div(rho, rho_hat):
    inv_rho = tf.subtract(tf.constant(1.), rho)
    inv_rho_hat = tf.subtract(tf.constant(1.), rho_hat)
    log_rho = logfunc(rho,rho_hat) + log_func(inv_rho, inv_rho_hat)
    return log_rho

# Model definition
encoder_op = encoder(X)
decoder_op = decoder(encoder_op)
rho_hat = tf.reduce_mean(encoder_op,1)
# Reconstructed output

```

```

y_pred = decoder_op
# Targets in the input data.
y_true = X

# Define the TensorFlow Ops for loss and optimizer, minimize the combined error
# Squared Reconstruction error
cost_m = tf.reduce_mean(tf.pow(y_true - y_pred, 2))
# KL Divergence Regularization to introduce sparsity
cost_sparse = 0.001*tf.reduce_sum(KL_Div(0.2,rho_hat))
# L2 Regularization of weights to keep the network stable
cost_reg = 0.0001* (tf.nn.l2_loss(weights['decoder_h1']) + tf.nn.l2_loss(weights
['encoder_h1']))
# Add up the costs
cost = tf.add(cost_reg,tf.add(cost_m,cost_sparse))

optimizer = tf.train.RMSPropOptimizer(learning_rate).minimize(cost)

# Initializing the variables
init = tf.global_variables_initializer()

# Launch the Session graph
start_time = time.time()
with tf.Session() as sess:
    sess.run(init)
    total_batch = int(mnist.train.num_examples/batch_size)

    for epoch in range(training_epochs):
        for i in range(total_batch):
            batch_xs, batch_ys = mnist.train.next_batch(batch_size)
            _, c = sess.run([optimizer, cost], feed_dict={X: batch_xs})
            if epoch % display_step == 0:
                print("Epoch:", '%04d' % (epoch+1),
                    "cost=", "{:.9f}".format(c))

    print("Optimization Finished!")

# Applying encode and decode over test set
encode_decode = sess.run(
    y_pred, feed_dict={X: mnist.test.images[:10]})
# Compare original images with their reconstructions
f, a = plt.subplots(2, 10, figsize=(10, 2))
for i in range(10):
    a[0][i].imshow(np.reshape(mnist.test.images[i], (28, 28)))
    a[1][i].imshow(np.reshape(encode_decode[i], (28, 28)))
# Store the Decoder and Encoder Weights
dec = sess.run(weights['decoder_h1'])
enc = sess.run(weights['encoder_h1'])
end_time = time.time()
print('elapsed time:',end_time - start_time)

-- Output --

```

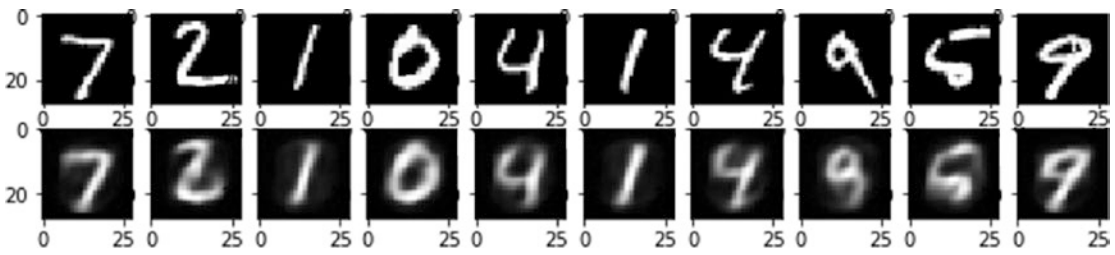

Figure 5-18. Display of the original image followed by the reconstructed image

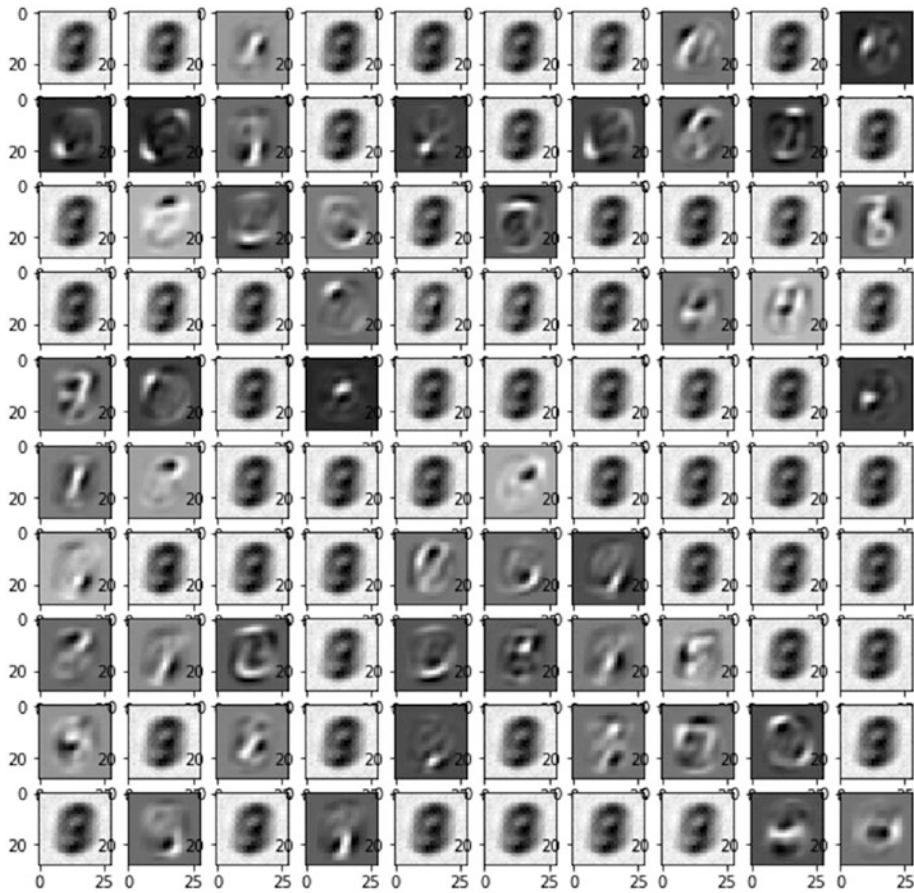

Figure 5-19. Display of a few encoder/decoder weights as images

Figure 5-18 shows the reconstruction of the images by sparse encoders while Figure 5-19 shows the decoder weights in the form of images. The weights corresponding to hidden unit layers are images being displayed in Figure 5-19. This gives you some idea as to the kind of features the sparse encoders are learning. The final image that is reconstructed is the linear combination of these images, with the hidden layer activations acting as the linear weights. Essentially, each of these images is detecting low-level features in the form of hand strokes for the written digits. In terms of linear algebra, these images form a basis for representing the reconstructed images.

Denoising Auto-Encoder

Denoising auto-encoders works like a standard auto-encoder, with non-linear activations in the hidden layers, the only difference being that instead of the original input x , a noisy version of x , say x' , is fed to the network. The reconstructed image at the output layer is compared with the actual input x while computing the error in reconstruction. The idea is that the hidden structure learned from the noisy data is rich enough to reconstruct the original data. Hence, this form of auto-encoder can be used for reducing noise in the data since it learns a robust representation of the data from the hidden layer. For example, if an image has been blurred by some distortion then a denoising auto-encoder can be used to remove the blur. An auto-encoder can be converted into a denoising auto-encoder by just introducing a stochastic noise addition unit.

For images, denoising auto-encoders can have hidden layers as convolutional layers instead of standard neural units. This ensures that the topological structure of the image is not compromised when defining the auto-encoder network.

A Denoising Auto-Encoder Implementation in TensorFlow

In this section, we will work through the implementation of a denoising auto-encoder that learns to remove noise from input images. Two kinds of noise have been introduced to the input images—namely, Gaussian and salt and pepper noise—and the implemented denoising auto-encoder can remove both of these efficiently. The detailed implementation is illustrated in Listing 5-5.

Listing 5-5. Denoising Auto-Encoder Using Convolution and Deconvolution Layers

```
# Import the required library
import tensorflow.contrib.layers as lays
import numpy as np
from skimage import transform
import tensorflow as tf
from tensorflow.examples.tutorials.mnist import input_data
import matplotlib.pyplot as plt

# Define the Network with Encoder and Decoder
def autoencoder(inputs):
    # encoder
    net = lays.conv2d(inputs, 32, [5, 5], stride=2, padding='SAME')
    net = lays.conv2d(net, 16, [5, 5], stride=2, padding='SAME')
    net = lays.conv2d(net, 8, [5, 5], stride=4, padding='SAME')
    # decoder
```

```

net = layers.conv2d_transpose(net, 16, [5, 5], stride=4, padding='SAME')
net = layers.conv2d_transpose(net, 32, [5, 5], stride=2, padding='SAME')
net = layers.conv2d_transpose(net, 1, [5, 5], stride=2, padding='SAME', activation_fn=tf.
nn.tanh)
return net

def resize_batch(imgs):
# Function to resize the image to 32x32 so that the dimensionality can be reduced in
# multiples of 2
img = imgs.reshape((-1, 28, 28, 1))
resized_imgs = np.zeros((imgs.shape[0], 32, 32, 1))
for i in range(imgs.shape[0]):
    resized_imgs[i, ..., 0] = transform.resize(imgs[i, ..., 0], (32, 32))
return resized_imgs

## Function to introduce Gaussian Noise
def noisy(image):
    row,col= image.shape
    mean = 0
    var = 0.1
    sigma = var**0.5
    gauss = np.random.normal(mean,sigma,(row,col))
    gauss = gauss.reshape(row,col)
    noisy = image + gauss
    return noisy

## Function to define Salt and Pepper Noise
def s_p(image):
    row,col = image.shape
    s_vs_p = 0.5
    amount = 0.05
    out = np.copy(image)
# Salt mode
    num_salt = np.ceil(amount * image.size * s_vs_p)
    coords = [np.random.randint(0, i - 1, int(num_salt)) for i in image.shape]
    out[coords] = 1

    # Pepper mode
    num_pepper = np.ceil(amount* image.size * (1. - s_vs_p))
    coords = [np.random.randint(0, i - 1, int(num_pepper)) for i in image.shape]
    out[coords] = 0
    return out
# Defining the ops

# input to which the reconstucted signal is compared to
a_e_inputs = tf.placeholder(tf.float32, (None, 32, 32, 1))
# input to the network (MNIST images)
a_e_inputs_noise = tf.placeholder(tf.float32, (None, 32, 32, 1))
a_e_outputs = autoencoder(a_e_inputs_noise) # create the Auto-encoder network

```

```

# calculate the loss and optimize the network
loss = tf.reduce_mean(tf.square(a_e_outputs - a_e_inputs)) # calculate the mean square
error loss
train_op = tf.train.AdamOptimizer(learning_rate=0.001).minimize(loss)

# initialize the network
init = tf.global_variables_initializer()

# Invoking the TensorFlow Graph for Gaussian Noise reduction auto-encoder training and
validation

batch_size = 1000 # Number of samples in each batch
epoch_num = 10 # Number of epochs to train the network
lr = 0.001 # Learning rate

# read MNIST dataset
mnist = input_data.read_data_sets("MNIST_data", one_hot=True)

# calculate the number of batches per epoch
batch_per_ep = mnist.train.num_examples // batch_size

with tf.Session() as sess:
    sess.run(init)
    for epoch in range(epoch_num):
        for batch_num in range(batch_per_ep):
            batch_img, batch_label = mnist.train.next_batch(batch_size) # read a batch
            batch_img = batch_img.reshape((-1, 28, 28, 1)) # reshape each
sample to an (28, 28) image
            batch_img = resize_batch(batch_img) # reshape the
images to (32, 32)
            ## Introduce noise in the input images
            image_arr = []
            for i in xrange(len(batch_img)):
                img = batch_img[i,:,:,:0]
                img = noisy(img)
                image_arr.append(img)
            image_arr = np.array(image_arr)
            image_arr = image_arr.reshape(-1,32,32,1)
            _, c = sess.run([train_op, loss], feed_dict={a_e_inputs_noise:image_arr,a_e_
inputs: batch_img})
            print('Epoch: {} - cost= {:.5f}'.format((ep + 1), c))

# test the trained network
batch_img, batch_label = mnist.test.next_batch(50)
batch_img = resize_batch(batch_img)
image_arr = []

for i in xrange(50):
    img = batch_img[i,:,:,:0]
    img = noisy(img)

```

```

    image_arr.append(img)
image_arr = np.array(image_arr)
image_arr = image_arr.reshape(-1,32,32,1)

reconst_img = sess.run([ae_outputs], feed_dict={ae_inputs_noise: image_arr})[0]

# plot the reconstructed images and the corresponding Noisy images
plt.figure(1)
plt.title('Input Noisy Images')
for i in range(50):
    plt.subplot(5, 10, i+1)
    plt.imshow(image_arr[i, ..., 0], cmap='gray')

plt.figure(2)
plt.title('Re-constructed Images')
for i in range(50):
    plt.subplot(5, 10, i+1)
    plt.imshow(reconst_img[i, ..., 0], cmap='gray')
plt.show()

```

--Output--

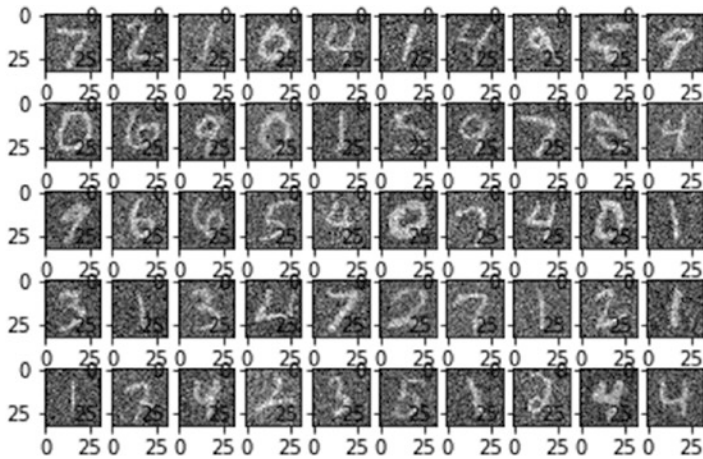

Figure 5-20. Images with Gaussian noise

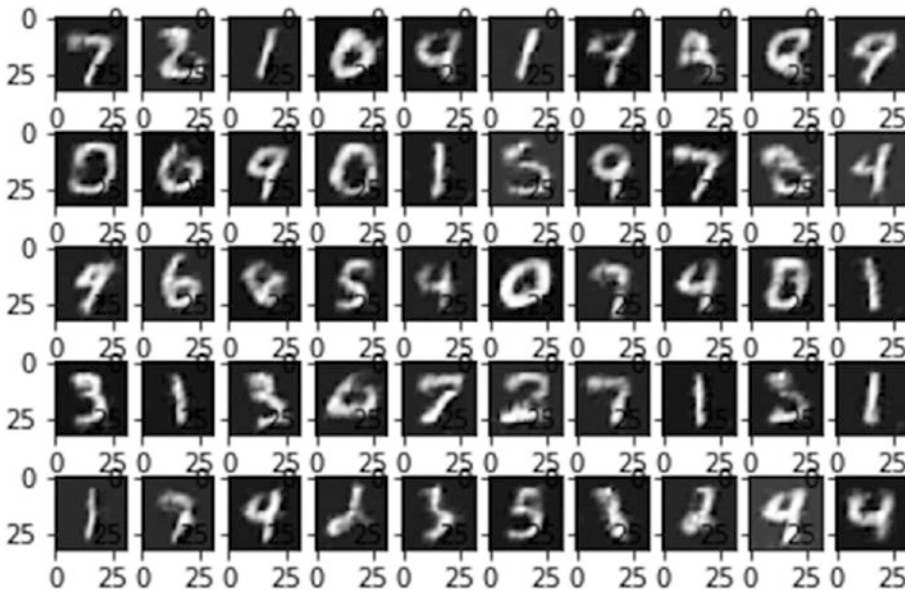

Figure 5-21. Reconstructed Images (without Gaussian Noise) generated by the Denoising Auto Encoder

We can see from Figure 5-20 and Figure 5-21 that the Gaussian noise has been removed by the denoising auto-encoders.

Invoking the TensorFlow Graph for Salt and Pepper Noise reduction auto-encoder training and validation

```
batch_size = 1000 # Number of samples in each batch
epoch_num = 10 # Number of epochs to train the network
lr = 0.001 # Learning rate
```

```
# read MNIST dataset
mnist = input_data.read_data_sets("MNIST_data", one_hot=True)
```

```
# calculate the number of batches per epoch
batch_per_ep = mnist.train.num_examples // batch_size
```

```
with tf.Session() as sess:
    sess.run(init)
    for epoch in range(epoch_num):
        for batch_num in range(batch_per_ep):
            batch_img, batch_label = mnist.train.next_batch(batch_size) # read a batch
            batch_img = batch_img.reshape((-1, 28, 28, 1)) # reshape each
            # sample to an (28, 28) image
            batch_img = resize_batch(batch_img) # reshape the
            # images to (32, 32)
            ## Introduce noise in the input images
            image_arr = []
            for i in xrange(len(batch_img)):
```



```

        img = batch_img[i,:,:0]
        img = noisy(img)
        image_arr.append(img)
    image_arr = np.array(image_arr)
    image_arr = image_arr.reshape(-1,32,32,1)
    _, c = sess.run([train_op, loss], feed_dict={a_e_inputs_noise:image_arr,a_e_
inputs: batch_img})
    print('Epoch: {} - cost= {:.5f}'.format((ep + 1), c))

# test the trained network
batch_img, batch_label = mnist.test.next_batch(50)
batch_img = resize_batch(batch_img)
image_arr = []

for i in xrange(50):
    img = batch_img[i,:,:0]
    img = noisy(img)
    image_arr.append(img)
image_arr = np.array(image_arr)
image_arr = image_arr.reshape(-1,32,32,1)

reconst_img = sess.run([ae_outputs], feed_dict={ae_inputs_noise: image_arr})[0]

# plot the reconstructed images and the corresponding Noisy images
plt.figure(1)
plt.title('Input Noisy Images')
for i in range(50):
    plt.subplot(5, 10, i+1)
    plt.imshow(image_arr[i, ..., 0], cmap='gray')

plt.figure(2)
plt.title('Re-constructed Images')
for i in range(50):
    plt.subplot(5, 10, i+1)
    plt.imshow(reconst_img[i, ..., 0], cmap='gray')
plt.show()

--Output--

```

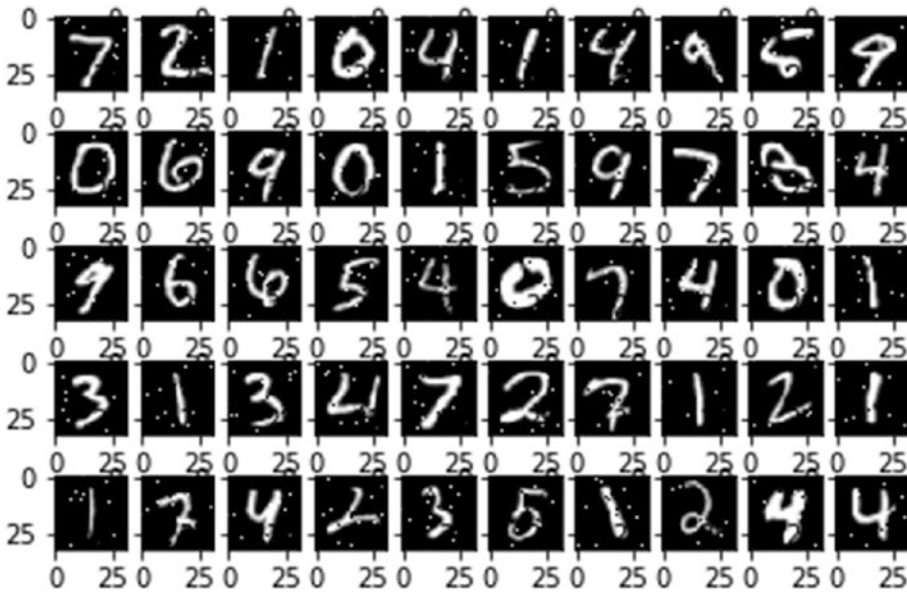

Figure 5-22. Salt and pepper noisy images

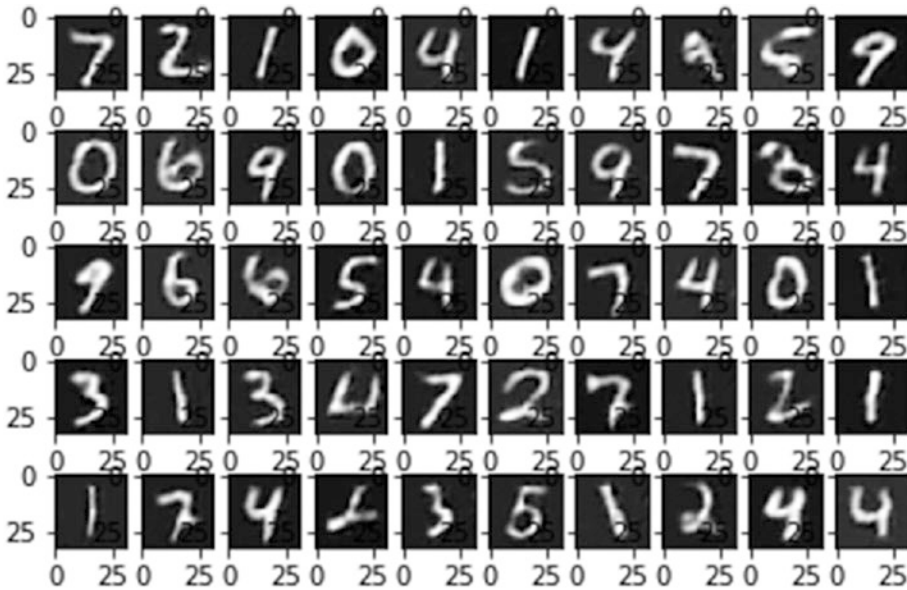

Figure 5-23. Reconstructed images without the salt and pepper noise generated by the denoising auto-encoder

From Figure 5-22 and Figure 5-23 it is evident that the denoising auto-encoder does a good job of removing the salt and pepper noise. Do note that the auto-encoders are trained separately, once for handling Gaussian noise and once for handling salt and pepper noise.

PCA and ZCA Whitening

Generally, images contain pixels whose intensities are highly correlated in any neighborhood of the image, and hence such correlation is highly redundant to a learning algorithm. These dependencies in the form of correlation between nearby pixels is generally of little use to any algorithm. Thus, it makes sense to remove this two-way correlation so that the algorithm puts more emphasis on higher-order correlations. Similarly, the mean intensity of an image might not be of any use to a learning algorithm in cases where the image is a natural image. Therefore, it makes sense to remove the mean intensity of an image. Do note that we are not subtracting the mean per-pixel location, but rather the mean of pixel intensities of each image. This kind of mean normalization is different from the other mean normalization we do in machine learning where we subtract the mean per feature computed over a training set. Coming back to the concept of whitening, the advantages of whitening are two-fold:

- Remove the correlation among features in the data
- Make the variance equal along each feature direction

PCA and ZCA whitening are two techniques generally used to pre-process images before the images are processed through artificial neural networks. These techniques are almost the same, with a subtle difference. The steps involved in PCA whitening are illustrated first, followed by ZCA.

- Remove the mean pixel intensity from each image separately. So, if a 2D image is converted into a vector, one can subtract the mean of the elements in the image vector from itself. If each image is represented by the vector $x^{(i)} \in \mathbb{R}^{n \times 1}$, where i represents the i th image in the training set, then the mean normalized image for $x^{(i)}$ is given by

$$x^{(i)} = x^{(i)} - \frac{1}{n} \sum_{j=1}^n x_j^{(i)}$$

- Once we have the mean normalized images we can compute the covariance matrix as follows:

$$C = \frac{1}{m} \sum_{i=1}^m x^{(i)} x^{(i)T}$$

- Next, we need to decompose the covariance matrix through singular value decomposition (SVD) as follows:

$$C = UDU^T$$

- In general, SVD decomposes as $C = UDV^T$, but since C is a symmetric matrix, $U = V$ in this case. U gives the Eigen vectors of the covariance matrix. The Eigen vectors are aligned in a column-wise fashion in U . The variances of the data along the direction of the Eigen vectors are given by the Eigen values housed along the diagonals of D , while the rest of the entries in D are zero since D is the covariance matrix for the uncorrelated directions given by the Eigen vectors.

- In PCA whitening, we project the data along the Eigen vectors, or one may say principal components, and then divide the projection value in each direction by the square root of the Eigen value—i.e., the standard deviation along that direction on which the data is projected. So, the PCA whitening transformation is as follows:

$$T = D^{-\frac{1}{2}}U^T$$

- Once this transformation is applied to the data, the transformed data has zero correlation and unit variance along the newly transformed components. The transformed data for original mean-corrected image $x^{(i)}$ is

$$x^{(i)}_{PW} = Tx^{(i)}$$

The problem with PCA whitening is that although it decorrelates the data and makes the new feature variances unity, the features are no longer in the original space but rather are in a transformed rotated space. This makes the structure of objects such as images lose a lot of information in terms of their spatial orientation, because in the transformed feature space each feature is the linear combination of all the features. For algorithms that make use of the spatial structure of the image, such as convolutional neural networks, this is not a good thing. So, we need some way to whiten the data such that the data is decorrelated and of unit variances along its features but the features are still in the original feature space and not in some transformed rotated feature space. The transformation that provides all these relevant properties is called ZCA transform. Mathematically, any orthogonal matrix R (the column vectors of which are orthogonal to each other) when multiplied by the PCA whitening transform T produces another whitening transform. If one chooses, $R=U$, and the transform

$$Z = UT = UD^{-\frac{1}{2}}U^T$$

is called the ZCA transform. The advantage of ZCA transform is that the image data still resides in the same feature space of pixels, and hence, unlike in PCA whitening, the original pixel doesn't get obscured by the creation of new features. At the same time, the data is whitened—i.e., decorrelated—and of unit variance for each of the features. The unit variance and decorrelated features may help several machine-learning or deep-learning algorithms achieve faster convergence. At the same time, since the features are still in the original space they retain their topological or spatial orientation, and algorithms such as convolutional neural networks that make use of the spatial structure of the image can make use of the information.

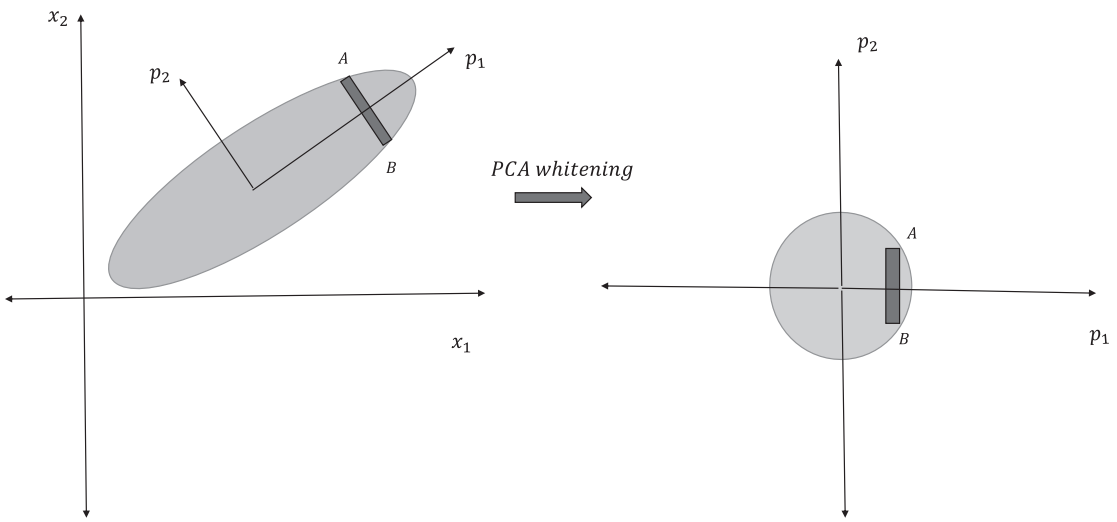

Figure 5-24. PCA whitening illustration

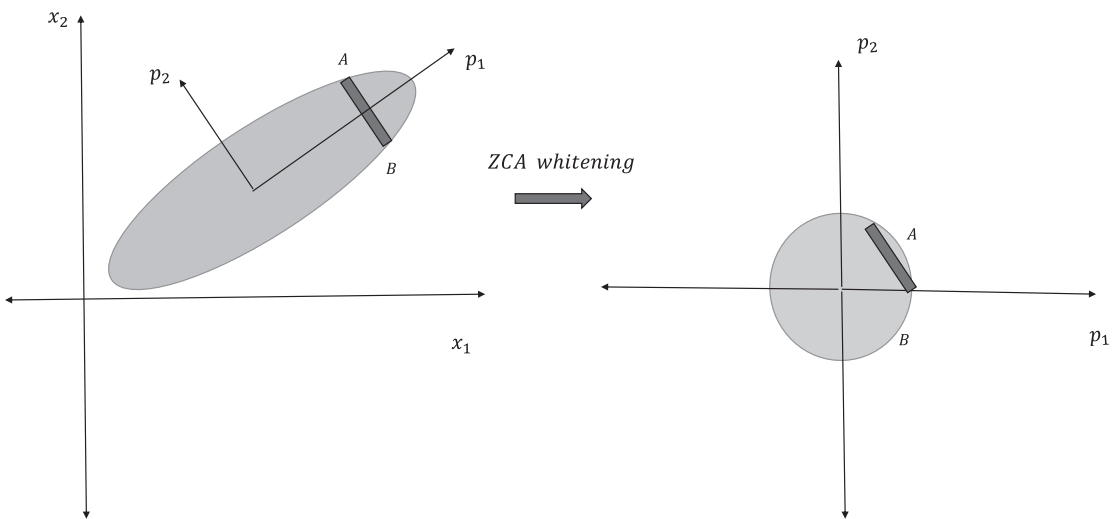

Figure 5-25. ZCA whitening illustration

The key difference between PCA whitening and ZCA whitening is illustrated in Figure 5-24 and Figure 5-25. As we can see, in both case the 2D correlated data is transformed into uncorrelated new data. However, there is a major difference. While in PCA whitening, the new axes have changed from the original axes based on the principal components given by p_1 and p_2 , the axes remain same as those of the original with ZCA whitening. The p_1 and p_2 are the Eigen vectors of the co-variance matrix for the data. Also, we see the orientation of the marker AB has changed in the new axes for PCA whitening while it remains intact for ZCA whitening. In both cases, the idea is to get rid of the not-so-useful two-way covariances between the input variables so that the model can concentrate on learning about higher-order correlations.

Summary

In this chapter, we went through the most popular unsupervised techniques in deep learning, namely, restricted Boltzmann machines and auto-encoders. Also, we discussed the different applications of using these methods and the training process related to each of these algorithms. Finally, we ended with PCA and ZCA whitening techniques, which are relevant pre-processing techniques used in several supervised deep-learning methods. By the end of this chapter, we had touched upon all the core methodologies in deep learning. Other improvised methods in deep learning can be easily comprehended and implemented given the methods and mathematics touched upon thus far.

In the next and final chapter, we will discuss several improvised deep-learning networks that have gained popularity in recent times, such as generative adversarial networks, R-CNN, and so forth, and touch upon aspects of taking a TensorFlow application into production with ease.

CHAPTER 6



Advanced Neural Networks

In this chapter, we will look at some of the advanced concepts and models in deep learning being used recently. Image segmentation and object localization and detection are some of the key areas that have garnered a lot of importance lately. Image segmentation plays a crucial role in detecting diseases and abnormalities through the processing of medical images. At the same time, it is equally crucial in industries such as aviation, manufacturing, and other domains to detect anomalies such as cracks or other unwanted conditions in machinery. Similarly images of the night sky can be segmented to detect previously unknown galaxies, stars and planets. Object detection and localization has profound use in places requiring constant automated monitoring of activities, such as in shopping malls, local stores, industrial plants, and so on. Also, it can be used to count objects and people in an area of interest and estimate various densities, such as traffic conditions at various signals.

We will begin this chapter by going through a few of the traditional methods of image segmentation so that we can appreciate how neural networks are different from their traditional counterparts. Then, we will look at object detection and localization techniques, followed by generative adversarial networks, which have gained a lot of popularity recently because of their use and potential as a generative model to create synthetic data. This synthetic data can be used for training and inference in case there is not much data available or the data is expensive to procure. Alternatively, generative models can be used for style transfer from one domain to another. Finally, we end with some guidelines as to how TensorFlow models can be implemented in production with ease using TensorFlow's serving capabilities.

Image Segmentation

Image segmentation is a computer-vision task involving the partitioning of an image into pertinent segments, such as pixels within the same segment that share some common attributes. The attributes can differ from domain to domain and from task to task, with the major attributes being pixel intensity, texture, and color. In this section, we will go through some basic segmentation techniques, such as thresholding methods based on a histogram of pixel intensities, watershed thresholding techniques, and so on, to get some insights about image segmentation before we start with the deep learning-based image-segmentation methods.

Binary Thresholding Method Based on Histogram of Pixel Intensities

Often in an image there are only two significant regions of interest—the object and the background. In such a scenario, a histogram of pixel intensities would represent a probability distribution that is bimodal; i.e., have high density around two-pixel intensity values. It would be easy to segment the object and the background by choosing a threshold pixel and setting all pixel intensities below the threshold as 255 and those above the threshold as 00. This activity would ensure that we have a background and an object

represented by white and black colors, not necessarily in that order. If an image is represented as $I(x, y)$ and a threshold t is selected based on the histogram of pixel intensities, then the new segmented image $I'(x, y)$ can be represented as

$$I'(x, y) = 0 \text{ when } I(x, y) > t \\ = 255 \text{ when } I(x, y) \leq t$$

When the bimodal histogram is not distinctly separated by a region of zero density in between, then a good strategy to choose a threshold t is to take the average of the pixel intensities at which the bimodal regions peak. If those peak intensities are represented by p_1 and p_2 then the threshold t can be chosen as

$$t = \frac{(p_1 + p_2)}{2}$$

Alternately, one may use the pixel intensity between p_1 and p_2 at which histogram density is minimum as the thresholding pixel intensity. If the histogram density function is represented by $H(p)$, where $p \in \{0, 1, 2, \dots, 255\}$ represents the pixel intensities, then

$$t = \underbrace{\text{Arg Min}}_{p \in [p_1, p_2]} H(p)$$

This idea of binary thresholding can be extended to multiple thresholding based on the histogram of pixel intensities.

Otsu's Method

Otsu's method determines the threshold by maximizing the variance between the different segments of the images. If using binary thresholding via Otsu's method, here are the steps to be followed:

- Compute the probability of each pixel intensity in the image. Given that N pixel intensities are possible, the normalized histogram would give us the probability distribution of the image.

$$P(i) = \frac{\text{count}(i)}{M} \quad \forall i \in \{0, 1, 2, \dots, N-1\}$$

- If the image has two segments C_1 and C_2 based on the threshold t , then the set of pixels $\{0, 2, \dots, t\}$ belong to C_1 while the set of pixels $\{t+1, t+2, \dots, L-1\}$ belong to C_2 . The variance between the two segments is determined by the sum of the square deviation of the mean of the clusters with respect to the global mean. The square deviations are weighted by the probability of each cluster.

$$\text{var}(C_1, C_2) = P(C_1)(u_1 - u)^2 + P(C_2)(u_2 - u)^2$$

where u_1, u_2 are the means of cluster 1 and cluster 2 while u is the overall global mean.

$$u_1 = \sum_{i=0}^t P(i)i \quad u_2 = \sum_{i=t+1}^{L-1} P(i)i \quad u = \sum_{i=0}^{L-1} P(i)i$$

The probability of each of the segments is the number of pixels in the image belonging to that class. The probability of segment C_1 is proportional to the number of pixels that have intensities less than or equal to the threshold intensity t , while that of segment C_2 is proportional to the number of pixels with intensities greater than threshold t . Hence,

$$P(C_1) = \sum_{i=0}^t P(i) \quad P(C_2) = \sum_{i=t+1}^{L-1} P(i)$$

- If we observe the expressions for $u_1, u_2, P(C_1)$, and $P(C_2)$, each of them is a function of the threshold t while the overall mean u is constant given an image. Hence, the between-segment variance $var(C_1, C_2)$ is a function of the threshold pixel intensity t . The threshold \hat{t} that maximizes the variance would provide us with the optimal threshold to use for segmentation using Otsu's method:

$$\hat{t} = \underset{t}{\text{Arg max}} \text{var}(C_1, C_2)$$

Instead of computing a derivative and then setting it to zero to obtain \hat{t} , one can evaluate the $var(C_1, C_2)$ at all values of $t = \{0, 1, 2, \dots, L-1\}$ and then choose the \hat{t} at which the $var(C_1, C_2)$ is maximum.

Otsu's method can also be extended to multiple segments where instead of one threshold one needs to determine $(k-1)$ thresholds corresponding to k segments for an image.

The logic for both methods just illustrated—i.e., binary thresholding based on histogram of pixel intensities as well as Otsu's method—has been illustrated in Listing 6-1 for reference. Instead of using an image-processing package to implement these algorithms, the core logic has been used for ease of interpretability. Also, one thing to note is that these processes for segmentation are generally applicable on grayscale images or if one is performing segmentation per color channel.

Listing 6-1. Python Implementation of Binary Thresholding Method Based on Histogram of Pixel Intensities and Otsu's Method

```
## Binary thresholding Method Based on Histogram of Pixel Intensities
import cv2
import matplotlib.pyplot as plt
##matplotlib inline
import numpy as np
img = cv2.imread("coins.jpg")
gray = cv2.cvtColor(img, cv2.COLOR_BGR2GRAY)
plt.imshow(gray, cmap='gray')
row, col = np.shape(gray)
gray_flat = np.reshape(gray, (row*col, 1))[:, 0]
ax = plt.subplot(222)
ax.hist(gray_flat, color='gray')
gray_const = []
## 150 pixel intensity seems a good threshold to choose since the density is minimum
## round 150
for i in xrange(len(gray_flat)):
    if gray_flat[i] < 150 :
        gray_const.append(255)
    else:
```

```

        gray_const.append(0)
gray_const = np.reshape(np.array(gray_const),(row,col))
bx = plt.subplot(333)
bx.imshow(gray_const,cmap='gray')

## Otsu's thresholding Method

img = cv2.imread("otsu.jpg")
gray = cv2.cvtColor(img,cv2.COLOR_BGR2GRAY)
plt.imshow(gray,cmap='gray')
row,col = np.shape(gray)
hist_dist = 256*[0]
## Compute the frequency count of each of the pixels in the image
for i in xrange(row):
    for j in xrange(col):
        hist_dist[gray[i,j]] += 1
# Normalize the frequencies to produce probabilities
hist_dist = [c/float(row*col) for c in hist_dist]
plt.plot(hist_dist)
## Compute the between segment variance
def var_c1_c2_func(hist_dist,t):
    u1,u2,p1,p2,u = 0,0,0,0,0
    for i in xrange(t+1):
        u1 += hist_dist[i]*i
        p1 += hist_dist[i]
    for i in xrange(t+1,256):
        u2 += hist_dist[i]*i
        p2 += hist_dist[i]
    for i in xrange(256):
        u += hist_dist[i]*i
    var_c1_c2 = p1*(u1 - u)**2 + p2*(u2 - u)**2
    return var_c1_c2
## Iteratively run through all the pixel intensities from 0 to 255 and choose the one that
## maximizes the variance

variance_list = []
for i in xrange(256):
    var_c1_c2 = var_c1_c2_func(hist_dist,i)
    variance_list.append(var_c1_c2)
## Fetch the threshold that maximizes the variance
t_hat = np.argmax(variance_list)

## Compute the segmented image based on the threshold t_hat
gray_recons = np.zeros((row,col))
for i in xrange(row):
    for j in xrange(col):
        if gray[i,j] <= t_hat :
            gray_recons[i,j] = 255
        else:
            gray_recons[i,j] = 0
plt.imshow(gray_recons,cmap='gray')

```

--output --

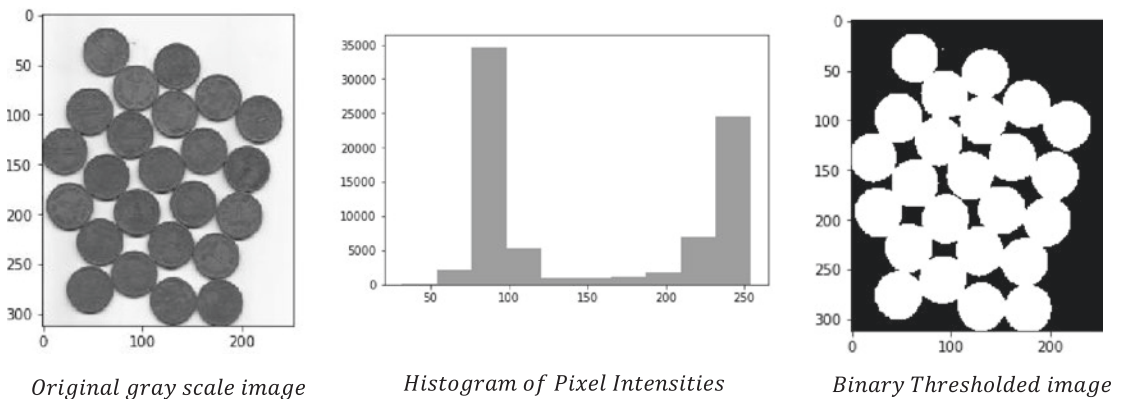

Figure 6-1. Binary thresholding method based on histogram of pixel intensities

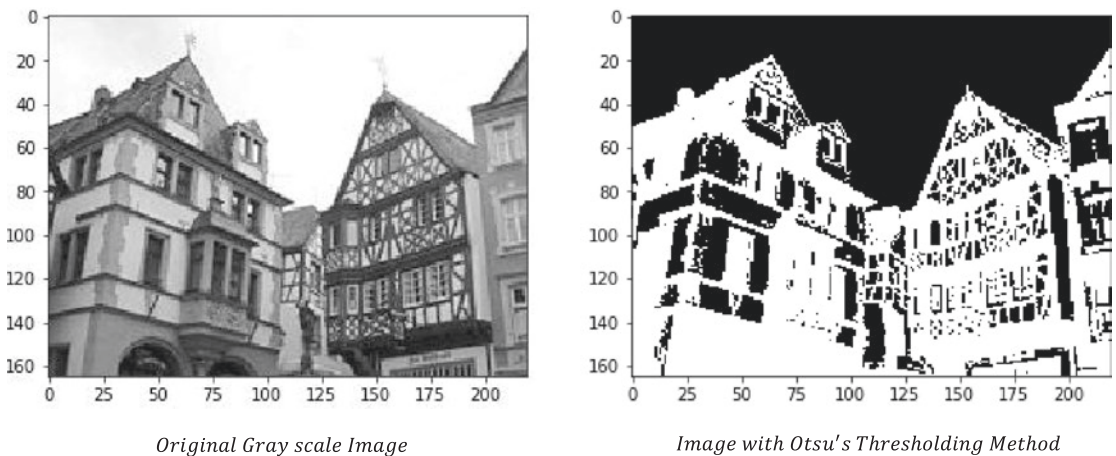

Figure 6-2. Otsu's method of thresholding

In Figure 6-1, the original grayscale image of the coin has been binary thresholded based on the histogram of pixel intensities to separate the objects (i.e., the coins) from the background. Based on the histogram of pixel intensities, the pixel intensity of 150 has been chosen as the thresholding pixel intensity. Pixel intensities below 150 have been set to 255 to represent the objects, while pixel intensities above 150 have been set to 0 to represent the background.

Figure 6-2 illustrates Otsu's method of thresholding for an image to produce two segments determined by the black and white colors. The black color represents the background while white represents the house. The optimal threshold for the image is a pixel intensity of 143.

Watershed Algorithm for Image Segmentation

The Watershed algorithm aims at segmenting topologically-placed local regions around local minima of pixel intensities. If a grayscale image pixel intensity value is considered a function of its horizontal and vertical coordinates, then this algorithm tries to find regions around local minima called basins of attraction or catchment basins. Once these basins are identified, the algorithm tries to separate them by constructing separations or watersheds along high peaks or ridges. To get a better idea of the method, let's show this algorithm with a simple illustration as represented in Figure 6-3.

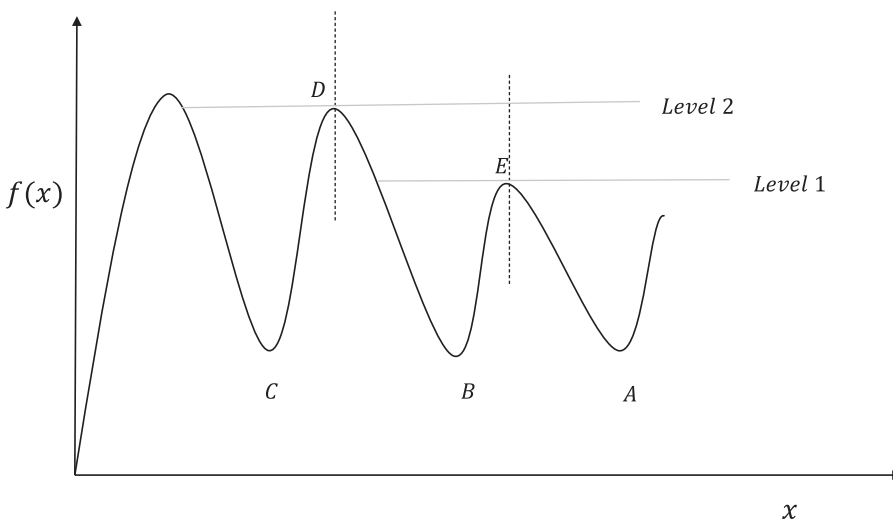

A, B, C – Minima of Catchment Basins

D, E – Peaks or Maximas where watersheds need to be constructed

Figure 6-3. Watershed algorithm illustration

If we start filling water in the catchment basin with its minima as *B*, water would keep on filling the basin up to Level 1, at which point an extra drop of water has a chance of spilling over to the catchment basin at *A*. To prevent the spilling of water, one needs to build a dam or watershed at *E*. Once we have built a watershed at *E*, we can continue filling water in the catchment basin *B* till Level 2, at which point an extra drop of water has a chance of spilling over to the catchment basin *C*. To prevent this spilling of water to *C*, one needs to build a watershed at *D*. Using this logic, we can continue to build watersheds to separate such catchment basins. This is the principal idea behind the Watershed algorithm. Here, the function is univariate, whereas in the case of a grayscale image the function representing the pixel intensities would be a function of two variables: the vertical and the horizontal coordinates.

The Watershed algorithm is particularly useful in detecting objects when there is overlap between them. Thresholding techniques are unable to determine distinct object boundaries. We will work through illustrating this in Listing 6-2 by applying Watershed techniques to an image containing overlapping coins.

Listing 6-2. Image Segmentation Using Watershed Algorithm

```
import numpy as np
import cv2
import matplotlib.pyplot as plt
from scipy import ndimage
from skimage.feature import peak_local_max
from skimage.morphology import watershed

## Load the coins image
im = cv2.imread("coins.jpg")
## Convert the image to grayscale
imgray = cv2.cvtColor(im, cv2.COLOR_BGR2GRAY)
plt.imshow(imgray, cmap='gray')
# Threshold the image to convert it to Binary image based on Otsu's method
```

```

thresh = cv2.threshold(imgray, 0, 255,
    cv2.THRESH_BINARY | cv2.THRESH_OTSU)[1]
## Detect the contours and display them
im2, contours, hierarchy = cv2.findContours(thresh,cv2.RETR_TREE,cv2.CHAIN_APPROX_SIMPLE)
y = cv2.drawContours(imgray, contours, -1, (0,255,0), 3)
## If we see the contour plots in the display of "y"
## we see that the coins have a common contour and hence it is not possible to separate them
plt.imshow(y,cmap='gray')
## Hence we will proceed with the Watershed algorithm so that each of the coins form its own
## cluster and thus it's possible to have separate contours for each coin.
## Relabel the thresholded image to be consisting of only 0 and 1
## as the input image to distance_transform_edt should be in this format.
thresh[thresh == 255] = 5
thresh[thresh == 0] = 1
thresh[thresh == 5] = 0
## The distance_transform_edt and the peak_local_max functions help building the markers by
## detecting
## points near the center points of the coins. One can skip these steps and create a marker
## manually by setting one pixel within each coin with a random number representing its
## cluster
D = ndimage.distance_transform_edt(thresh)
localMax = peak_local_max(D, indices=False, min_distance=10,
    labels=thresh)
markers = ndimage.label(localMax, structure=np.ones((3, 3)))[0]
# Provide the EDT distance matrix and the markers to the watershed algorithm to detect the
# cluster's
# labels for each pixel. For each coin, the pixels corresponding to it will be filled with
# the cluster number
labels = watershed(-D, markers, mask=thresh)
print("[INFO] {} unique segments found".format(len(np.unique(labels)) - 1))
# Create the contours for each label(each coin) and append to the plot
for k in np.unique(labels):
    if k != 0 :
        labels_new = labels.copy()
        labels_new[labels == k] = 255
        labels_new[labels != k] = 0
        labels_new = np.array(labels_new,dtype='uint8')
        im2, contours, hierarchy = cv2.findContours(labels_new,cv2.RETR_TREE,cv2.CHAIN_
APPROX_SIMPLE)
        z = cv2.drawContours(imgray,contours, -1, (0,255,0), 3)
        plt.imshow(z,cmap='gray')

--output --

```

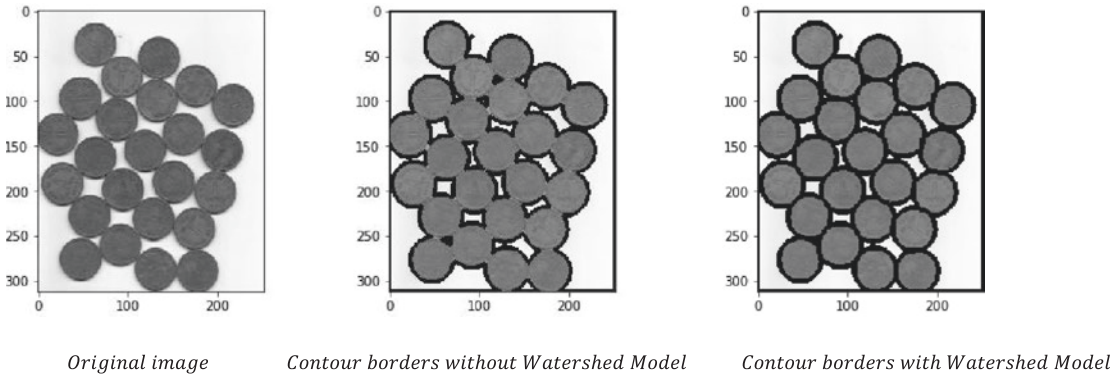

Figure 6-4. Illustration of Watershed algorithm for image segmentation)

As we can see from Figure 6-4, the borders for overlapping coins are distinct after applying the Watershed algorithm, whereas the other thresholding methods are not able provide a distinct border to each of the coins.

Image Segmentation Using K-means Clustering

The famous *K*-means algorithm can be used to segment images, especially medical images. The term *K* is a parameter to the algorithm which determines the number of distinct clusters to be formed. The algorithm works by forming clusters, and each such cluster is represented by its cluster centroids based on specific input features. For image segmentation through *K*-means, generally the segmentation is based on input features such as pixel intensity and its three spatial dimensions; i.e., horizontal and vertical coordinates and the color channel. So, the input feature vector can be represented as $u \in \mathbb{R}^{4 \times 1}$, where

$$u = [I(x, y, z), x, y, z]^T$$

Similarly, one can ignore the spatial coordinates and take the pixel intensities along the three color channels as the input feature vector; i.e.,

$$u = [I_R(x, y), I_G(x, y), I_B(x, y)]^T$$

where $I_R(x, y)$, $I_G(x, y)$, and $I_B(x, y)$ represent the pixel intensities along the Red, Green, and Blue channels respectively at the spatial coordinates (x, y) .

The algorithm uses a distance measure such as an L^2 or L^1 norm, as shown here:

$$D(u^{(i)}, u^{(j)} / L^2) = \|u^{(i)} - u^{(j)}\|_2 = \sqrt{u^{(i)} - u^{(j)} \cdot (u^{(i)} - u^{(j)})^T}$$

$$D(u_i, u_j / L^1) = \|u^{(i)} - u^{(j)}\|_1$$

The following are the working details of the K -means algorithm

- *Step 1* – Start with K randomly selected cluster centroids C_1, C_2, \dots, C_k corresponding to the K clusters S_1, S_2, \dots, S_k .
- *Step 2* – Compute the distance of each pixel feature vector $u^{(i)}$ from the cluster centroids and tag it to the cluster S_j if the pixel has a minimum distance from its cluster centroid C_j :

$$j = \underbrace{\text{Arg Min}}_j \left\| u^{(i)} - C_j \right\|_{l_2}$$

- This process needs to be repeated for all the pixel-feature vectors so that in one iteration of K -means all the pixels are tagged to one of the K clusters.
- *Step 3* – Once the new centroids clusters have been assigned for all the pixels, the centroids are recomputed by taking the mean of the pixel-feature vectors in each cluster:

$$C_j = \sum_{u^{(i)} \in S_j} u^{(i)}$$

- Repeat *Step 2* and *Step 3* for several iterations until the centroids no longer change. Through this iterative process, we are reducing the sum of the intra-cluster distances, as represented here:

$$L = \sum_{j=1}^K \sum_{u^{(i)} \in S_j} \left\| u^{(i)} - C_j \right\|_2$$

A simple implementation of the K -means algorithm is shown in Listing 6-3, taking the pixel intensities in the three color channels as features. The image segmentation is implemented with $K = 3$. The output is shown in grayscale and hence may not reveal the actual quality of the segmentation. However, if the same segmented image as produced in Listing 6-3 is displayed in a color format, it would reveal the finer details of the segmentation. One more thing to add: the cost or loss functions minimized—i.e., the sum of the intra-cluster distances—is a non-convex function and hence might suffer from local minima problems. One can trigger the segmentation several times with different initial values for the cluster centroids and then take the one that minimizes the cost function the most or produces a reasonable segmentation.

Listing 6-3. Image Segmentation Using K -means

```
import cv2
import numpy as np
import matplotlib.pyplot as plt
#np.random.seed(0)
img = cv2.imread("kmeans.jpg")
imggray_ori = cv2.cvtColor(img,cv2.COLOR_BGR2GRAY)
plt.imshow(imggray_ori,cmap='gray')
## Save the dimensions of the image
row,col,depth = img.shape
## Collapse the row and column axis for faster matrix operation.
img_new = np.zeros(shape=(row*col,3))
glob_ind = 0
for i in xrange(row):
    for j in xrange(col):
        u = np.array([img[i,j,0],img[i,j,1],img[i,j,2]])
```

```

    img_new[glob_ind,:] = u
    glob_ind += 1
# Set the number of clusters
K = 5
# Run the K-means for
num_iter = 20
for g in xrange(num_iter):
# Define cluster for storing the cluster number and out_dist to store the distances from
centroid
    clusters = np.zeros((row*col,1))
    out_dist = np.zeros((row*col,K))
    centroids = np.random.randint(0,255,size=(K,3))
    for k in xrange(K):
        diff = img_new - centroids[k,:]
        diff_dist = np.linalg.norm(diff,axis=1)
        out_dist[:,k] = diff_dist
# Assign the cluster with minimum distance to a pixel location
    clusters = np.argmin(out_dist,axis=1)
# Recompute the clusters
    for k1 in np.unique(clusters):
        centroids[k1,:] = np.sum(img_new[clusters == k1,:],axis=0)/np.sum([clusters == k1])
# Reshape the cluster labels in two-dimensional image form
clusters = np.reshape(clusters,(row,col))
out_image = np.zeros(img.shape)
#Form the 3D image with the labels replaced by their corresponding centroid pixel intensities
for i in xrange(row):
    for j in xrange(col):
        out_image[i,j,0] = centroids[clusters[i,j],0]
        out_image[i,j,1] = centroids[clusters[i,j],1]
        out_image[i,j,2] = centroids[clusters[i,j],2]

out_image = np.array(out_image,dtype="uint8")
# Display the output image after converting into grayscale
# Readers advised to display the image as it is for better clarity
imggray = cv2.cvtColor(out_image,cv2.COLOR_BGR2GRAY)
plt.imshow(imggray,cmap='gray')

```

---Output ---

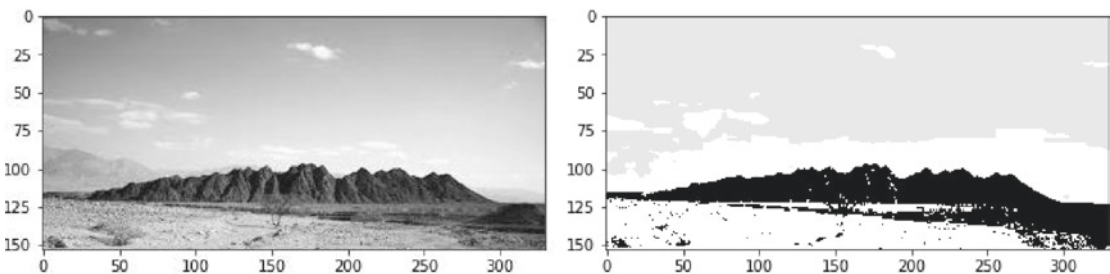

Original Image

Segmented Image with K = 3

Figure 6-5. Illustration of segmentation through the K-means algorithm

We can see from Figure 6-5 that K -means clustering has done a good job segmenting the image for $K = 3$.

Semantic Segmentation

Image segmentation through convolutional neural networks has gained a lot of popularity in recent years. One of the things significantly different when segmenting an image through neural networks is the annotation process of assigning each pixel to an object class so that the training of such a segmentation network is totally supervised. Although the process of annotating images is a costly affair, it simplifies the problem by having a ground truth to compare to. The ground truth would be in the form of an image with the pixels holding a representative color for a specific object. For example, if we are working with a cats and dogs image and the images can have a background, then each pixel for an image can belong to one of the three classes—cat, dog, and background. Also, each class of object is generally represented by a representative color so that the ground truth can be displayed as a segmented image. Let's go through some convolutional neural networks that can perform semantic segmentation.

Sliding-Window Approach

One can extract patches of images from the original image by using a sliding window and then feeding those patches to a classification convolutional neural network to predict the class of the central pixel for each of the image patches. Training such a convolutional neural network with this sliding-window approach is going to be computationally intensive, both at training and at test time, since at least N number of patches per image need to be fed to the classification CNN, where N denotes the number of pixels in the image.

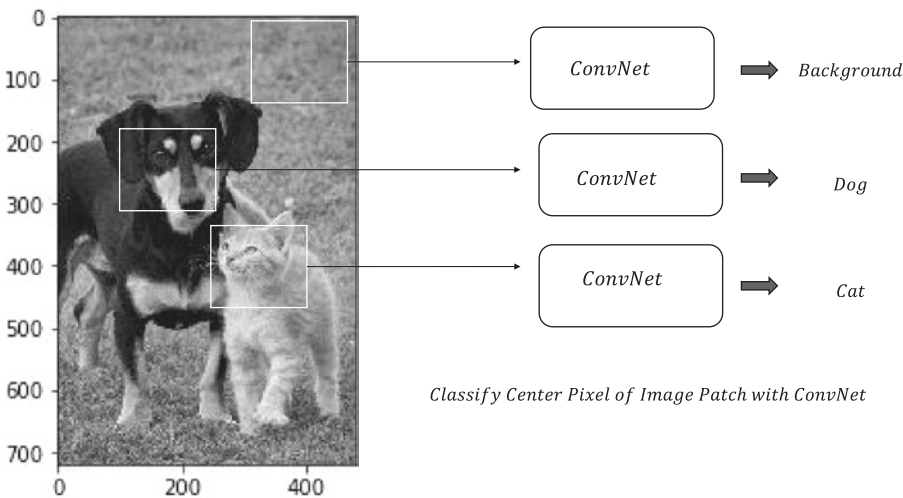

Figure 6-6. Sliding-window semantic segmentation

Illustrated in Figure 6-6 is a sliding-window semantic segmentation network for segmenting images of cat, dog, and background. It crops out patches from the original image and feeds it through the classification CNN for classifying the center pixel in the patch. A pre-trained network such as AlexNet, VGG19, Inception V3, and so forth can be used as the classification CNN, with the output layer replaced to have only three classes pertaining to the labels for dog, cat, and background. The CNN can then be fine-tuned through backpropagation, with the image patches as input and the class label of the center pixel of the input image patch as output. Such a network is highly inefficient from a convolution of images standpoint since image patches next to each other will have significant overlap and re-processing them every time independently leads to unwanted computational overhead. To overcome the shortcomings of the above Network one can use a Fully Convolutional Network which is our next topic of discussion.

Fully Convolutional Network (FCN)

A fully convolutional network consists of a series of convolutional layers without any fully connected layers. The convolutions are chosen such that the input image is transmitted without any change in the spatial dimensions; i.e., the height and width of the image remains the same. Rather than having individual patches from an image independently evaluated for pixel category, as in the sliding-window approach, a fully convolutional network predicts all the pixel categories at once. The output layer of this network consists of C feature maps, where C is the number of categories, including the background, that each pixel can be classified into. If the height and width of the original image are h and w respectively, then the output consists of C number of $h \times w$ feature maps. Also, for the ground truth there should be C number of segmented images corresponding to the C classes. At any spatial coordinate (h_1, w_1) , each of the feature maps contains the score of that pixel pertaining to the class the feature map is tied to. These scores across the feature maps for each spatial pixel location (h_1, w_1) form a SoftMax over the different classes.

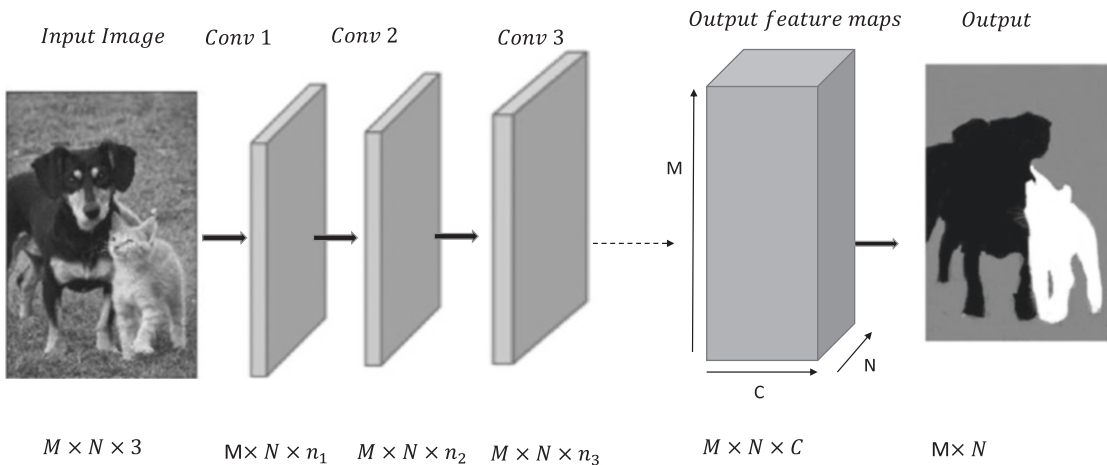

Figure 6-7. Fully convolutional network architecture

Figure 6-7 contains the architectural design of a fully convolutional network. The number of output feature maps as well as ground truth feature maps would be three, corresponding to the three classes. If the input net activation or score at the spatial coordinate (i, j) for the k th class is denoted by $s_k^{(i, j)}$, then the probability of the k th class for the pixel at spatial coordinate (i, j) is given by the SoftMax probability, as shown here:

$$P_k(i, j) = \frac{e^{s_k^{(i, j)}}}{\sum_{k'=1}^C e^{s_{k'}^{(i, j)}}}$$

Also, if the ground truth labels at the spatial coordinate (i, j) for the k th class are given by $y_k(i, j)$, then the cross-entropy loss of the pixel at spatial location (i, j) can be denoted by

$$L(i, j) = - \sum_{k=1}^C y_k(i, j) \log P_k(i, j)$$

If the height and width of the images fed to the network are M and N respectively, then the total loss for an image is

$$L = - \sum_{i=0}^{M-1} \sum_{j=0}^{N-1} \sum_{k=1}^C y_k(i, j) \log P_k(i, j)$$

The images can be fed as a mini batch to the network, and hence the average loss per image can be taken as the loss or cost function to be optimized in each epoch of mini-batch learning through gradient descent.

The output class \hat{k} for a pixel at spatial location (i, j) can be determined by taking the class k for which the probability $P_k(i, j)$ is maximum; i.e.,

$$\hat{k} = \underset{k}{\text{Arg max}} P_k(i, j)$$

The same activity needs to be performed for pixels at all spatial locations of an image to get the final segmented image.

In Figure 6-8, the output feature maps of a network for segmenting images of cats, dogs, and background are illustrated. As we can see, for each of the three categories or classes there is a separate feature map. The spatial dimensions of the feature maps are the same as those of the input image. The net input activation, the associated probability, and the corresponding ground label have been shown at the spatial coordinate (i, j) for all the three classes.

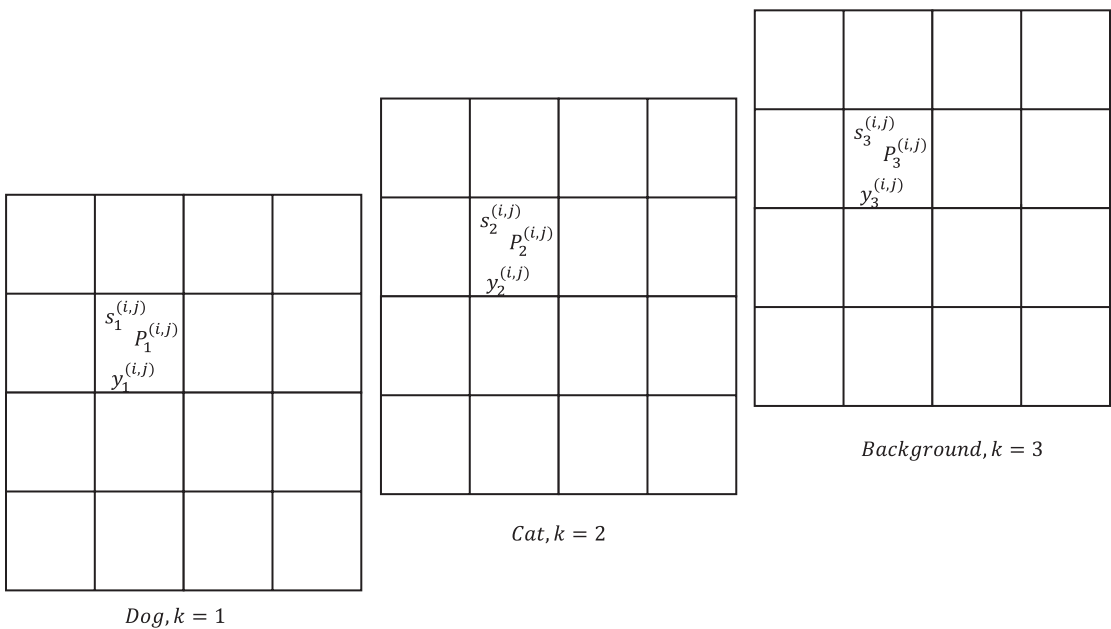

Figure 6-8. Output feature maps corresponding to each of the three classes for dog, cat, and background

All the convolutions in this network retain the spatial dimensions of the input image. So, for high-resolution images the network would be computationally intensive, especially if the number of feature maps or channels in each convolution is high. To address this problem, a different variant of a fully convolutional neural network is more widely used that both downsamples the image in the first half of the network and then upsamples the images within the second half of the network. This modified version of the fully convolutional network is going to be our next topic of discussion.

Fully Convolutional Network with Downsampling and Upsampling

Instead of preserving the spatial dimensions of the images in all convolutional layers as in the previous network, this variant of the fully convolutional network uses a combination of convolutions where the image is downsampled in the first half of the network and then upsampled in the final layers to restore the spatial dimensions of the original image. Generally, such a network consists of several layers of downsampling through strided convolutions and/or pooling operations and then a few layers of upsampling. Until now, through the convolution operation we have either downsampled the image or kept the spatial dimensions of the output image the same as those of the input. In this network, we would need to upsample an image, or rather the feature maps. Illustrated in Figure 6-9 is a high-level architectural design of such a network.

Similarly, one may choose to populate only one pixel in the neighborhood and set the rest to zero, as illustrated in Figure 6-10 (B).

Max Unpooling

Many of the fully convolutional layers are symmetric, as a pooling operation in the first half of the network would have a corresponding unpooling in the second half of the network to restore the image size. Whenever pooling is performed, minute spatial information about the input image is lost because of the summarizing of the results of neighboring pixels by one representative element. For instance, when we do max pooling by a 2x2 kernel, the maximum pixel value of each neighborhood is passed on to the output to represent the 2x2 neighborhood. From the output, it would not be possible to infer the location of the maximum pixel value. So, in this process we are missing the spatial information about the input. In semantic segmentation, we want to classify each pixel as close to its true label as possible. However, because of max pooling, a lot of information about edges and other finer details of the image is lost. While we are trying to rebuild the image through unpooling, one way we can restore a bit of this lost spatial information is to place the value of the input pixel in the output location corresponding to the one where the max pooling output got its input from. To visualize it better, let's look at the illustration in Figure 6-11.

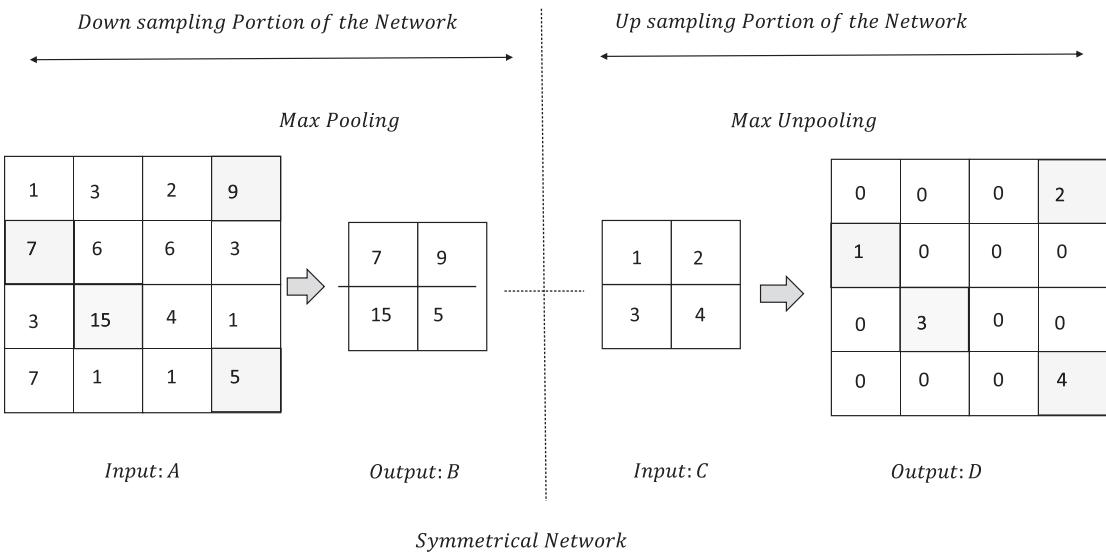

Figure 6-11. Max unpooling illustration for a symmetric fully connected segmentation network

As we can see from the Figure 6-11 while Unpooling only the locations in output map D corresponding to the location of the maximal elements in Input A with respect to MaxPooling are populated with values. This method of unpooling is generally called *max unpooling*.

Transpose Convolution

The upsampling done through unpooling or max unpooling are fixed transformations. These transformations don't involve any parameters that the network needs to learn while training the network. A learnable way to do upsampling is to perform upsampling through transpose convolution, which is much like convolution operations that we know of. Since transpose convolution involves parameters that would be learned by the network, the network would learn to do the upsampling in such a way that the overall cost function on which the network is trained reduces. Now, let's get into the details of how transpose convolution works.

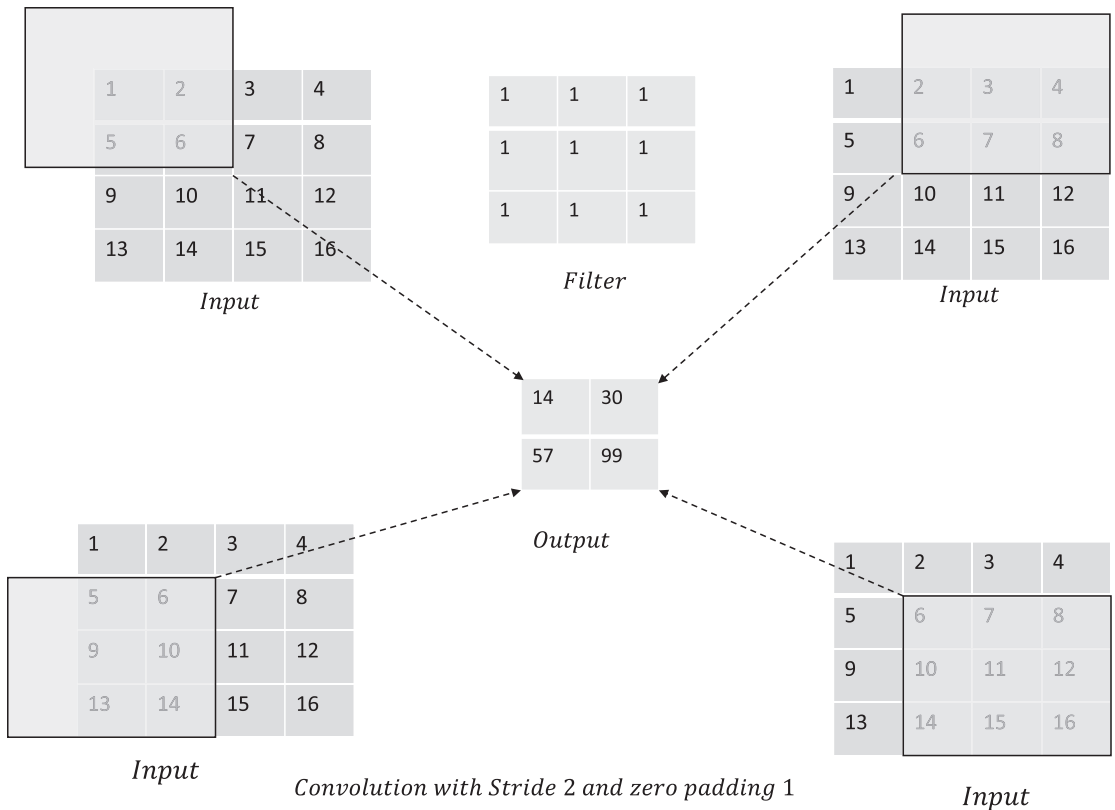

Figure 6-12. Strided convolution operation for downsampling an image

In strided convolution, the output dimensions are almost half those of the input for each spatial dimension for a stride of 2. Figure 6-12 illustrates the operation of convolving a 2D input of dimension 5x5 with a 4x4 kernel with a stride of 2 and zero padding of 1. We slide the kernel over the input, and at each position the kernel is on, the dot product of the kernel is computed with the portion of the input the kernel is overlapping with.

In transpose convolution, we use the same kind of logic, but instead of downsampling, strides greater than 1 provide upsampling. So, if we use a stride of 2, then the input size is doubled in each spatial dimension. Figures 6-13a, 6-13b, and 6-13c illustrate the operation of transpose convolution for an input of dimension 2×2 by a filter or kernel size of 3×3 to produce a 4×4 output. Unlike the dot product between the filter and the portions of input as in convolution, in transpose convolution, at a specific location the filter values are weighted by the input value at which the filter is placed, and the weighted filter values are populated in the corresponding locations in the output. The outputs for successive input values along the same spatial dimension are placed at a gap determined by the stride of the transpose convolution. The same is performed for all input values. Finally, the outputs corresponding to each of the input values are added to produce the final output, as shown in Figure 6-13c.

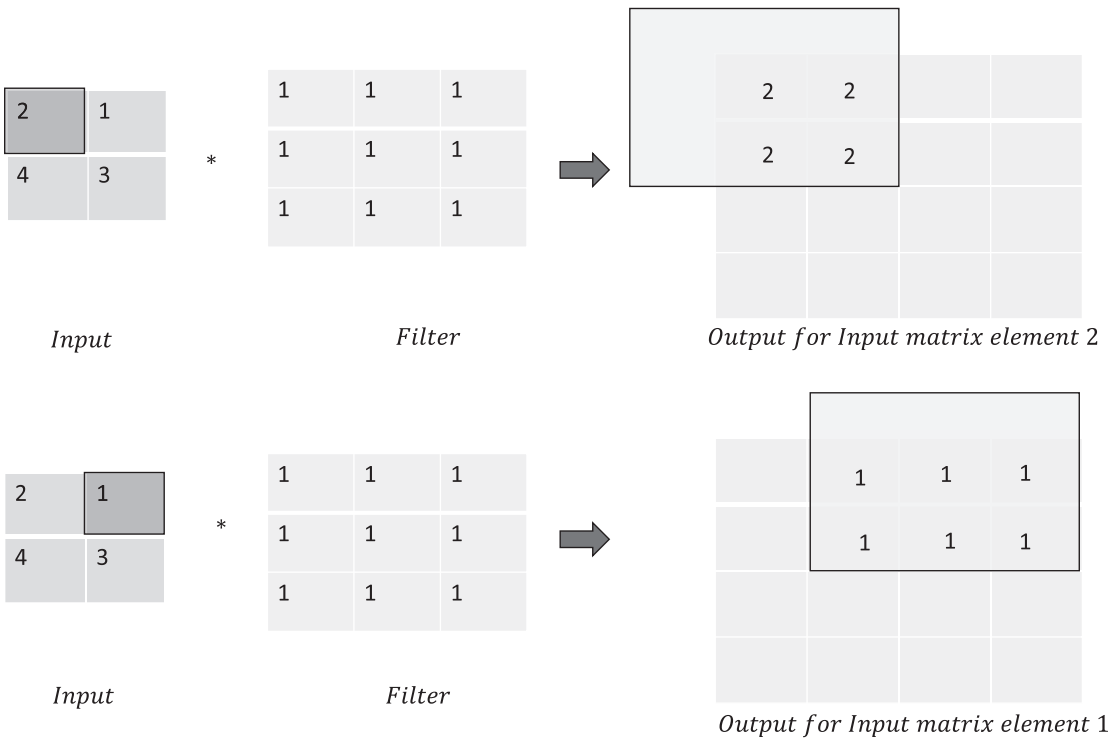

Figure 6-13a. Transpose convolution for upsampling

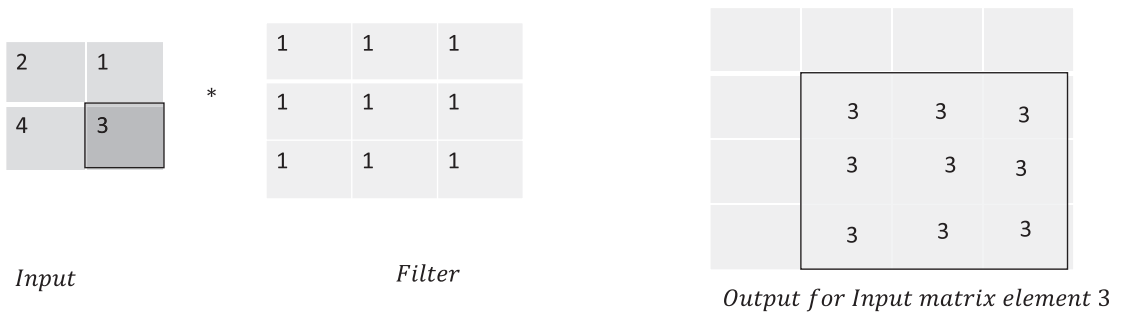
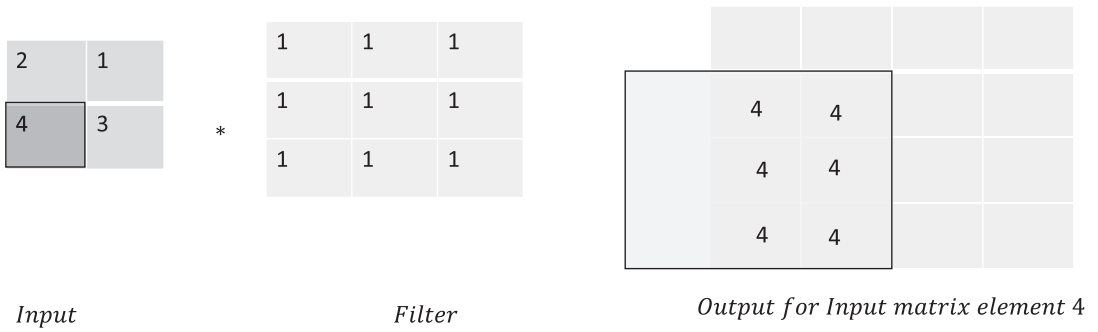

Figure 6-13b. Transpose convolution for upsampling

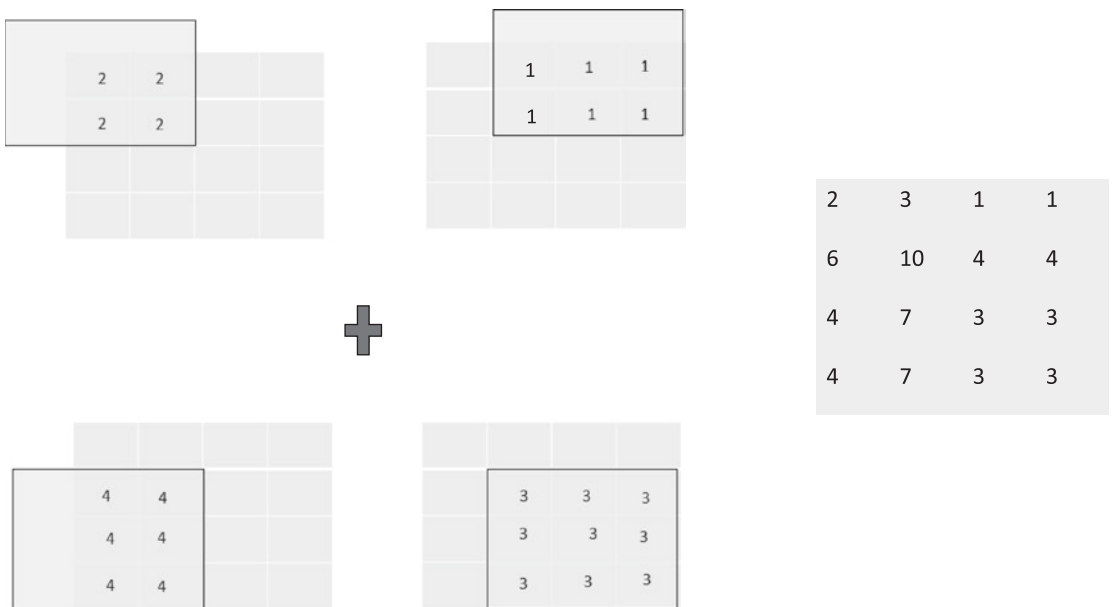

Figure 6-13c. Transpose convolution for upsampling

In TensorFlow, the function `tf.nn.conv2d_transpose` can be used to perform upsampling through transpose convolution.

U-Net

The U-Net convolutional neural network is one of the most efficient architectures in recent times for the segmentation of images, especially medical images. This U-Net architecture won the Cell Tracking Challenge at ISBI 2015. The network topology follows a U-shape pattern from the input to the output layers, hence the name U-Net. [Olaf Ronneberger](#), [Philipp Fischer](#), and [Thomas Brox](#) came up with this convolutional neural network for segmentation, and the details of the model are illustrated in the white paper “U-Net: Convolutional Networks for Biomedical Image Segmentation.” The paper can be located at <https://arxiv.org/abs/1505.04597>.

In the first part of the network, the images undergo downsampling through a combination of convolution and max-pooling operations. The convolutions are associated with pixel-wise ReLU activations. Every convolution operation is with 3×3 filter size and without zero padding, which leads to a reduction of two pixels in each spatial dimension for the output feature maps. In the second part of the network, the downsampled images are upsampled till the final layer, where output feature maps correspond to specific classes of objects being segmented. The cost function per image would be pixel-wise categorical cross-entropy or log loss for classification summed over the whole image, as we saw earlier. One thing to note is that the output feature maps in a U-Net have less spatial dimension than those of the input. For example, an input image having spatial dimensions of 572×572 produces output feature maps of spatial dimension 388×388 . One might ask how the pixel-to-pixel class comparison is done for loss computation for training. The idea is simple—the segmented output feature maps are compared to a ground truth segmented image of patch size 388×388 extracted from the center of the input image. The central idea is that if one has images of higher resolution, say 1024×1024 , one can randomly create many images of spatial dimensions 572×572 from it for training purposes. Also, the ground truth images are created from these 572×572 sub-images by extracting the central 388×388 patch and labeling each pixel with its corresponding class. This helps train the network with a significant amount of data even if there are not many images around for training. Illustrated in Figure 6-14 is the architecture diagram of a U-Net.

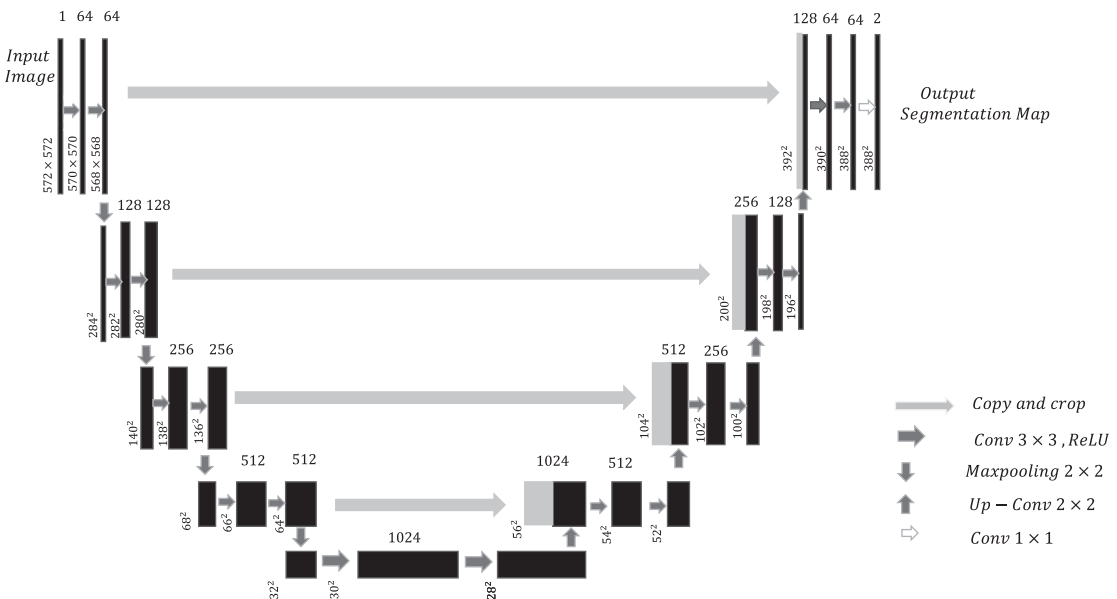

Figure 6-14. U-Net architecture diagram

We can see from the architecture diagram that in the first part of the network the images undergo convolution and max pooling to reduce the spatial dimensions and at the same time increase the channel depth; i.e., to increase the number of feature maps. Every two successive convolutions, along with their associated ReLU activations, are followed by a max-pooling operation, which reduces the image size by $\frac{1}{4}$.

Every max-pooling operation brings the network down to the next set of convolutions and contributes to the U-shape in the first part of the network. Similarly, the upsampling layers increase the spatial dimensions by two in each dimension and hence increase the image size by four times. Also, it provides the U structure to the network in the second part. After every upsampling, the image goes through two convolutions and their associated ReLU activations.

The U-Net is a very symmetric network as far as the operations of max pooling and upsampling are concerned. However, for a corresponding pair of max pooling and upsampling, the image size before the max pooling is not the same as the image size after upsampling, unlike with other fully convolutional layers. As discussed earlier, when a max-pooling operation is done a lot of spatial information is lost by having a representative pixel in the output corresponding to a local neighborhood of the image. It becomes difficult to recover this lost spatial information when the image is upsampled back to its original dimensions, and hence the new image lacks a lot of information around the edges and other finer aspects of the image too. This leads to sub-optimal segmentation. Had the upsampled image been of the same spatial dimensions as the image before its corresponding max-pooling operation, one could have just appended a random number of feature maps before max pooling with the output feature maps after upsampling to help the network recover a bit of the lost spatial information. Since in the case of U-Net these feature-map dimensions don't match, U-Net crops the feature maps before max pooling to be of the same spatial dimensions as the output feature maps from upsampling and concatenates them. This leads to better segmentation of images, as it helps recover some spatial information lost during max pooling. One more thing to note is that upsampling can be done by any of the methods that we have looked at thus far, such as unpooling, max unpooling, and transpose convolution, which is also known as deconvolution.

Few of the big wins with U-Net Segmentation are as below:

- A significant amount of training data can be generated with only a few annotated or hand-labeled segmented images.
- The U-Net does good segmentation even when there are touching objects of the same class that need to be separated. As we saw earlier with traditional image-processing methods, separating touching objects of the same class is tough, and methods such as the Watershed algorithm require a lot of input in terms of object markers to come up with reasonable segmentation. The U-Net does good separation between touching segments of the same class by introducing high weights for misclassification of pixels around the borders of touching segments.

Semantic Segmentation in TensorFlow with Fully Connected Neural Networks

In this section, we will go through the working details of a TensorFlow implementation for the segmentation of car images from the background based on the Kaggle Competition named Carvana. The input images, along with their ground truth segmentation, are available for training purposes. We train the model on 80 percent of the training data and validate the performance of the model on the remaining 20 percent of the data. For training, we use a fully connected convolutional network with a U-Net-like structure in the first half of the network followed by upsampling through transpose convolution. A couple of things different in this network from a U-Net is that the spatial dimensions are kept intact while performing convolution by using padding as *SAME*. The other thing different is that this model doesn't use the skip connections to concatenate feature maps from the downsampling stream to the upsampling stream. The detailed implementation is provided in Listing 6-4.

Listing 6-4. Semantic Segmentation in TensorFlow with Fully Connected Neural Network

```

## Load the required packages
import tensorflow as tf
from sklearn.model_selection import train_test_split
import matplotlib.pyplot as plt
%matplotlib inline
import os
from subprocess import check_output
import numpy as np
from keras.preprocessing.image import array_to_img, img_to_array, load_img,
ImageDataGenerator
from scipy.misc import imresize

# Define downsampling - 2 (Conv+ReLU) and 1 Maxpooling
# Maxpooling can be set to False when needed

x = tf.placeholder(tf.float32,[None,128,128,3])
y = tf.placeholder(tf.float32,[None,128,128,1])

def down_sample(x,w1,b1,w2,b2,pool=True):
    x = tf.nn.conv2d(x,w1, strides=[1,1,1,1],padding='SAME')
    x = tf.nn.bias_add(x,b1)
    x = tf.nn.relu(x)
    x = tf.nn.conv2d(x,w2, strides=[1,1,1,1],padding='SAME')
    x = tf.nn.bias_add(x,b2)
    x = tf.nn.relu(x)
    if pool:
        y = tf.nn.max_pool(x, ksize=[1,2,2,1],strides=[1,2,2,1],padding='SAME')
        return y,x
    else:
        return x

# Define upsampling
def up_sample(x,w,b):
    output_shape = x.get_shape().as_list()
    output_shape[0] = 32
    output_shape[1] *= 2
    output_shape[2] *= 2
    output_shape[1] = np.int(output_shape[1])
    output_shape[2] = np.int(output_shape[2])
    output_shape[3] = w.get_shape().as_list()[2]
    conv_tf = tf.nn.conv2d_transpose(value=x,filter=w,output_shape=output_shape,strides=
[1,2,2,1],padding="SAME")
    conv_tf = tf.nn.bias_add(conv_tf,b)
    return tf.nn.relu(conv_tf)

```

```

## Define weights

weights = {
    'w11': tf.Variable(tf.random_normal([3,3,3,64],mean=0.0,stddev=0.02)),
    'w12': tf.Variable(tf.random_normal([3,3,64,64],mean=0.0,stddev=0.02)),
    'w21': tf.Variable(tf.random_normal([3,3,64,128],mean=0.0,stddev=0.02)),
    'w22': tf.Variable(tf.random_normal([3,3,128,128],mean=0.0,stddev=0.02)),
    'w31': tf.Variable(tf.random_normal([3,3,128,256],mean=0.0,stddev=0.02)),
    'w32': tf.Variable(tf.random_normal([3,3,256,256],mean=0.0,stddev=0.02)),
    'w41': tf.Variable(tf.random_normal([3,3,256,512],mean=0.0,stddev=0.02)),
    'w42': tf.Variable(tf.random_normal([3,3,512,512],mean=0.0,stddev=0.02)),
    'w51': tf.Variable(tf.random_normal([3,3,512,1024],mean=0.0,stddev=0.02)),
    'w52': tf.Variable(tf.random_normal([3,3,1024,1024],mean=0.0,stddev=0.02)),
    'wu1': tf.Variable(tf.random_normal([3,3,1024,1024],mean=0.0,stddev=0.02)),
    'wu2': tf.Variable(tf.random_normal([3,3,512,1024],mean=0.0,stddev=0.02)),
    'wu3': tf.Variable(tf.random_normal([3,3,256,512],mean=0.0,stddev=0.02)),
    'wu4': tf.Variable(tf.random_normal([3,3,128,256],mean=0.0,stddev=0.02)),
    'wf': tf.Variable(tf.random_normal([1,1,128,1],mean=0.0,stddev=0.02))
}

biases = {
    'b11': tf.Variable(tf.random_normal([64],mean=0.0,stddev=0.02)),
    'b12': tf.Variable(tf.random_normal([64],mean=0.0,stddev=0.02)),
    'b21': tf.Variable(tf.random_normal([128],mean=0.0,stddev=0.02)),
    'b22': tf.Variable(tf.random_normal([128],mean=0.0,stddev=0.02)),
    'b31': tf.Variable(tf.random_normal([256],mean=0.0,stddev=0.02)),
    'b32': tf.Variable(tf.random_normal([256],mean=0.0,stddev=0.02)),
    'b41': tf.Variable(tf.random_normal([512],mean=0.0,stddev=0.02)),
    'b42': tf.Variable(tf.random_normal([512],mean=0.0,stddev=0.02)),
    'b51': tf.Variable(tf.random_normal([1024],mean=0.0,stddev=0.02)),
    'b52': tf.Variable(tf.random_normal([1024],mean=0.0,stddev=0.02)),
    'bu1': tf.Variable(tf.random_normal([1024],mean=0.0,stddev=0.02)),
    'bu2': tf.Variable(tf.random_normal([512],mean=0.0,stddev=0.02)),
    'bu3': tf.Variable(tf.random_normal([256],mean=0.0,stddev=0.02)),
    'bu4': tf.Variable(tf.random_normal([128],mean=0.0,stddev=0.02)),
    'bf': tf.Variable(tf.random_normal([1],mean=0.0,stddev=0.02))
}

## Create the final model

def unet_basic(x,weights,biases,dropout=1):

    ## Convolutional 1
    out1,res1 = down_sample(x,weights['w11'],biases['b11'],weights['w12'],biases['b12'],
    pool=True)
    out1,res1 = down_sample(out1,weights['w21'],biases['b21'],weights['w22'],biases['b22'],
    pool=True)
    out1,res1 = down_sample(out1,weights['w31'],biases['b31'],weights['w32'],biases['b32'],
    pool=True)
    out1,res1 = down_sample(out1,weights['w41'],biases['b41'],weights['w42'],biases['b42'],
    pool=True)

```

```

out1      = down_sample(out1,weights['w51'],biases['b51'],weights['w52'],biases['b52'],
pool=False)
up1       = up_sample(out1,weights['wu1'],biases['bu1'])
up1       = up_sample(up1,weights['wu2'],biases['bu2'])
up1       = up_sample(up1,weights['wu3'],biases['bu3'])
up1       = up_sample(up1,weights['wu4'],biases['bu4'])
out       = tf.nn.conv2d(up1,weights['wf'],strides=[1,1,1,1],padding='SAME')
out       = tf.nn.bias_add(out,biases['bf'])
return out

## Create generators for pre-processing the images and making a batch available at runtime
## instead of loading all the images and labels in memory
# set the necessary directories
data_dir = "/home/santanu/Downloads/Carvana/train/" # Contains the input training data
mask_dir = "/home/santanu/Downloads/Carvana/train_masks/" # Contains the growth truth labels
all_images = os.listdir(data_dir)
# pick which images we will use for testing and which for validation
train_images, validation_images = train_test_split(all_images, train_size=0.8, test_
size=0.2)
# utility function to convert grayscale images to rgb
def grey2rgb(img):
    new_img = []
    for i in range(img.shape[0]):
        for j in range(img.shape[1]):
            new_img.append(list(img[i][j])*3)
    new_img = np.array(new_img).reshape(img.shape[0], img.shape[1], 3)
    return new_img

# generator that we will use to read the data from the directory
def data_gen_small(data_dir, mask_dir, images, batch_size, dims):
    """
    data_dir: where the actual images are kept
    mask_dir: where the actual masks are kept
    images: the filenames of the images we want to generate batches from
    batch_size: self explanatory
    dims: the dimensions in which we want to rescale our images
    """
    while True:
        ix = np.random.choice(np.arange(len(images)), batch_size)
        imgs = []
        labels = []
        for i in ix:
            # images
            original_img = load_img(data_dir + images[i])
            resized_img = imresize(original_img, dims+[3])
            array_img = img_to_array(resized_img)/255
            imgs.append(array_img)

            # masks
            original_mask = load_img(mask_dir + images[i].split(".")[0] + '_mask.gif')
            resized_mask = imresize(original_mask, dims+[3])

```

```

        array_mask = img_to_array(resized_mask)/255
        labels.append(array_mask[:, :, 0])
    imgs = np.array(imgs)
    labels = np.array(labels)
    yield imgs, labels.reshape(-1, dims[0], dims[1], 1)

train_gen = data_gen_small(data_dir, mask_dir, train_images,32, [128, 128])
validation_gen = data_gen_small(data_dir, mask_dir, validation_images,32, [128, 128])

display_step=10
learning_rate=0.0001

keep_prob = tf.placeholder(tf.float32)
logits = unet_basic(x,weights,biases)
flat_logits = tf.reshape(tensor=logits, shape=(-1, 1))
flat_labels = tf.reshape(tensor=y,shape=(-1, 1))
cross_entropies = tf.nn.sigmoid_cross_entropy_with_logits(logits=flat_logits,
                                                           labels=flat_labels)

cost = tf.reduce_mean(cross_entropies)
optimizer = tf.train.AdamOptimizer(learning_rate=learning_rate).minimize(cost)

# Evaluate model

## initializing all variables

init = tf.global_variables_initializer()

## Launch the execution Graph

with tf.Session() as sess:
    sess.run(init)
    for batch in xrange(500):
        batch_x,batch_y= next(train_gen)
        sess.run(optimizer, feed_dict={x:batch_x,y:batch_y})
        loss = sess.run([cost],feed_dict={x:batch_x,y:batch_y})
        ## Validation loss and store the result for display at the end
        val_x,val_y = next(validation_gen)
        loss_val = sess.run([cost],feed_dict={x:val_x,y:val_y})
        out_x = sess.run(logits,feed_dict={x:val_x})
        print('batch:',batch,'train loss:',loss,'validation loss:',loss_val)

## To judge the segmentation quality of the Model we plot the segmentation for couple of the
validation images.
## These validation images were evaluated in the last batch of training. Bear in mind that
the model hasn't been
## trained on these validation images.

img = (out_x[1] > 0.5)*1.0
plt.imshow(grey2rgb(img),alpha=0.5)
plt.imshow(val_x[1])
plt.imshow(grey2rgb(val_y[1]), alpha=0.5)

```

```
img = (out_x[2] > 0.5)*1.0
plt.imshow(grey2rgb(img),alpha=0.5)
plt.imshow(val_x[2])
plt.imshow(grey2rgb(val_y[2]), alpha=0.5)
```

-output-

```
'batch:', 400, 'train loss:', [0.044453222], 'validation loss:', [0.058442257])
('batch:', 401, 'train loss:', [0.049510699], 'validation loss:', [0.055530164])
('batch:', 402, 'train loss:', [0.048047166], 'validation loss:', [0.055518236])
('batch:', 403, 'train loss:', [0.049462996], 'validation loss:', [0.049190756])
('batch:', 404, 'train loss:', [0.047011156], 'validation loss:', [0.051120583])
('batch:', 405, 'train loss:', [0.046235155], 'validation loss:', [0.052921098])
('batch:', 406, 'train loss:', [0.051339123], 'validation loss:', [0.054767497])
('batch:', 407, 'train loss:', [0.050004266], 'validation loss:', [0.052718181])
('batch:', 408, 'train loss:', [0.048425209], 'validation loss:', [0.054115709])
('batch:', 409, 'train loss:', [0.05234601], 'validation loss:', [0.053246532])
('batch:', 410, 'train loss:', [0.054224499], 'validation loss:', [0.05121265])
('batch:', 411, 'train loss:', [0.050268434], 'validation loss:', [0.056970511])
('batch:', 412, 'train loss:', [0.046658799], 'validation loss:', [0.058863375])
('batch:', 413, 'train loss:', [0.048009872], 'validation loss:', [0.049314644])
('batch:', 414, 'train loss:', [0.053399611], 'validation loss:', [0.050949663])
('batch:', 415, 'train loss:', [0.047932044], 'validation loss:', [0.049477436])
('batch:', 416, 'train loss:', [0.054921247], 'validation loss:', [0.059221379])
('batch:', 417, 'train loss:', [0.053222295], 'validation loss:', [0.061699588])
('batch:', 418, 'train loss:', [0.047465689], 'validation loss:', [0.051628478])
('batch:', 419, 'train loss:', [0.055220582], 'validation loss:', [0.056656662])
('batch:', 420, 'train loss:', [0.052862987], 'validation loss:', [0.048487194])
('batch:', 421, 'train loss:', [0.052869596], 'validation loss:', [0.049040388])
('batch:', 422, 'train loss:', [0.050372943], 'validation loss:', [0.052676879])
('batch:', 423, 'train loss:', [0.048104074], 'validation loss:', [0.05687784])
('batch:', 424, 'train loss:', [0.050506901], 'validation loss:', [0.055646997])
('batch:', 425, 'train loss:', [0.042940177], 'validation loss:', [0.047789834])
('batch:', 426, 'train loss:', [0.04780338], 'validation loss:', [0.05711592])
('batch:', 427, 'train loss:', [0.051617432], 'validation loss:', [0.051806655])
('batch:', 428, 'train loss:', [0.047577277], 'validation loss:', [0.052631289])
('batch:', 429, 'train loss:', [0.048690431], 'validation loss:', [0.044696849])
('batch:', 430, 'train loss:', [0.046005826], 'validation loss:', [0.050702494])
('batch:', 431, 'train loss:', [0.05022176], 'validation loss:', [0.053923506])
('batch:', 432, 'train loss:', [0.041961089], 'validation loss:', [0.047880188])
('batch:', 433, 'train loss:', [0.05004932], 'validation loss:', [0.057072558])
('batch:', 434, 'train loss:', [0.04603707], 'validation loss:', [0.049482994])
('batch:', 435, 'train loss:', [0.047554974], 'validation loss:', [0.050586618])
('batch:', 436, 'train loss:', [0.046048313], 'validation loss:', [0.047748547])
('batch:', 437, 'train loss:', [0.047006462], 'validation loss:', [0.059268739])
('batch:', 438, 'train loss:', [0.045432612], 'validation loss:', [0.051733252])
('batch:', 439, 'train loss:', [0.048241541], 'validation loss:', [0.04774794])
('batch:', 440, 'train loss:', [0.046124499], 'validation loss:', [0.048809234])
('batch:', 441, 'train loss:', [0.049743906], 'validation loss:', [0.051254783])
('batch:', 442, 'train loss:', [0.047674596], 'validation loss:', [0.048125759])
('batch:', 443, 'train loss:', [0.048984651], 'validation loss:', [0.04512443])
```



```

('batch:', 444, 'train loss:', [0.045365792], 'validation loss:', [0.042732101])
('batch:', 445, 'train loss:', [0.046680171], 'validation loss:', [0.050935686])
('batch:', 446, 'train loss:', [0.04224021], 'validation loss:', [0.052455597])
('batch:', 447, 'train loss:', [0.045161027], 'validation loss:', [0.045499101])
('batch:', 448, 'train loss:', [0.042469904], 'validation loss:', [0.050128322])
('batch:', 449, 'train loss:', [0.047899902], 'validation loss:', [0.050441738])
('batch:', 450, 'train loss:', [0.043648213], 'validation loss:', [0.048811793])
('batch:', 451, 'train loss:', [0.042413067], 'validation loss:', [0.051744446])
('batch:', 452, 'train loss:', [0.047555752], 'validation loss:', [0.04977461])
('batch:', 453, 'train loss:', [0.045962822], 'validation loss:', [0.047307629])
('batch:', 454, 'train loss:', [0.050115541], 'validation loss:', [0.050558448])
('batch:', 455, 'train loss:', [0.045722887], 'validation loss:', [0.049715079])
('batch:', 456, 'train loss:', [0.042583987], 'validation loss:', [0.048713747])
('batch:', 457, 'train loss:', [0.040946022], 'validation loss:', [0.045165032])
('batch:', 458, 'train loss:', [0.045971408], 'validation loss:', [0.046652604])
('batch:', 459, 'train loss:', [0.045015588], 'validation loss:', [0.055410333])
('batch:', 460, 'train loss:', [0.045542594], 'validation loss:', [0.047741935])
('batch:', 461, 'train loss:', [0.04639449], 'validation loss:', [0.046171311])
('batch:', 462, 'train loss:', [0.047501944], 'validation loss:', [0.046123035])
('batch:', 463, 'train loss:', [0.043643478], 'validation loss:', [0.050230302])
('batch:', 464, 'train loss:', [0.040434662], 'validation loss:', [0.046641909])
('batch:', 465, 'train loss:', [0.046465941], 'validation loss:', [0.054901786])
('batch:', 466, 'train loss:', [0.049838047], 'validation loss:', [0.048461676])
('batch:', 467, 'train loss:', [0.043582849], 'validation loss:', [0.052996978])
('batch:', 468, 'train loss:', [0.050299261], 'validation loss:', [0.048585847])
('batch:', 469, 'train loss:', [0.046049926], 'validation loss:', [0.047540378])
('batch:', 470, 'train loss:', [0.042139661], 'validation loss:', [0.047782935])
('batch:', 471, 'train loss:', [0.046433724], 'validation loss:', [0.049313426])
('batch:', 472, 'train loss:', [0.047063917], 'validation loss:', [0.045388222])
('batch:', 473, 'train loss:', [0.045556825], 'validation loss:', [0.044953942])
('batch:', 474, 'train loss:', [0.046181824], 'validation loss:', [0.045763671])
('batch:', 475, 'train loss:', [0.047123503], 'validation loss:', [0.047637179])
('batch:', 476, 'train loss:', [0.046167117], 'validation loss:', [0.051462833])
('batch:', 477, 'train loss:', [0.043556783], 'validation loss:', [0.044357236])
('batch:', 478, 'train loss:', [0.04773742], 'validation loss:', [0.046332739])
('batch:', 479, 'train loss:', [0.04820114], 'validation loss:', [0.045707334])
('batch:', 480, 'train loss:', [0.048089884], 'validation loss:', [0.052449297])
('batch:', 481, 'train loss:', [0.041174423], 'validation loss:', [0.050378591])
('batch:', 482, 'train loss:', [0.049479648], 'validation loss:', [0.047861829])
('batch:', 483, 'train loss:', [0.041197944], 'validation loss:', [0.051383432])
('batch:', 484, 'train loss:', [0.051363751], 'validation loss:', [0.050520841])
('batch:', 485, 'train loss:', [0.047751397], 'validation loss:', [0.046632469])
('batch:', 486, 'train loss:', [0.049832929], 'validation loss:', [0.048640732])
('batch:', 487, 'train loss:', [0.049518026], 'validation loss:', [0.048658002])
('batch:', 488, 'train loss:', [0.051349726], 'validation loss:', [0.051405452])
('batch:', 489, 'train loss:', [0.041912809], 'validation loss:', [0.046458714])
('batch:', 490, 'train loss:', [0.047130216], 'validation loss:', [0.052001398])
('batch:', 491, 'train loss:', [0.041481428], 'validation loss:', [0.046243563])
('batch:', 492, 'train loss:', [0.042776003], 'validation loss:', [0.042228915])
('batch:', 493, 'train loss:', [0.043606419], 'validation loss:', [0.048132997])
('batch:', 494, 'train loss:', [0.047129884], 'validation loss:', [0.046108384])

```

```

('batch:', 495, 'train loss:', [0.043634158], 'validation loss:', [0.046292961])
('batch:', 496, 'train loss:', [0.04454672], 'validation loss:', [0.044108659])
('batch:', 497, 'train loss:', [0.048068151], 'validation loss:', [0.044547819])
('batch:', 498, 'train loss:', [0.044967934], 'validation loss:', [0.047069982])
('batch:', 499, 'train loss:', [0.041554678], 'validation loss:', [0.051807735])
    
```



Figure 6-15a. Segmentation results on the validation dataset with model trained on 128×128 -size images

The average training loss and the validation loss are almost the same, which indicates that the model is not overfitting and is generalizing well. As we can see from Figure 6-15a, the results of segmentation look convincing based on the provided ground truths. The spatial dimensions of the images used for this network are 128×128 . On increasing the spatial dimensions of the input images to 512×512 , the accuracy and segmentation increase significantly. Since it’s a fully convolutional network with no fully connected layers, very few changes in the network are required to handle the new image size. The output of segmentation for a couple of validation dataset images are presented in Figure 6-15b to illustrate the fact that bigger image sizes are most of the time beneficial for image segmentation problems since it helps capture more context.

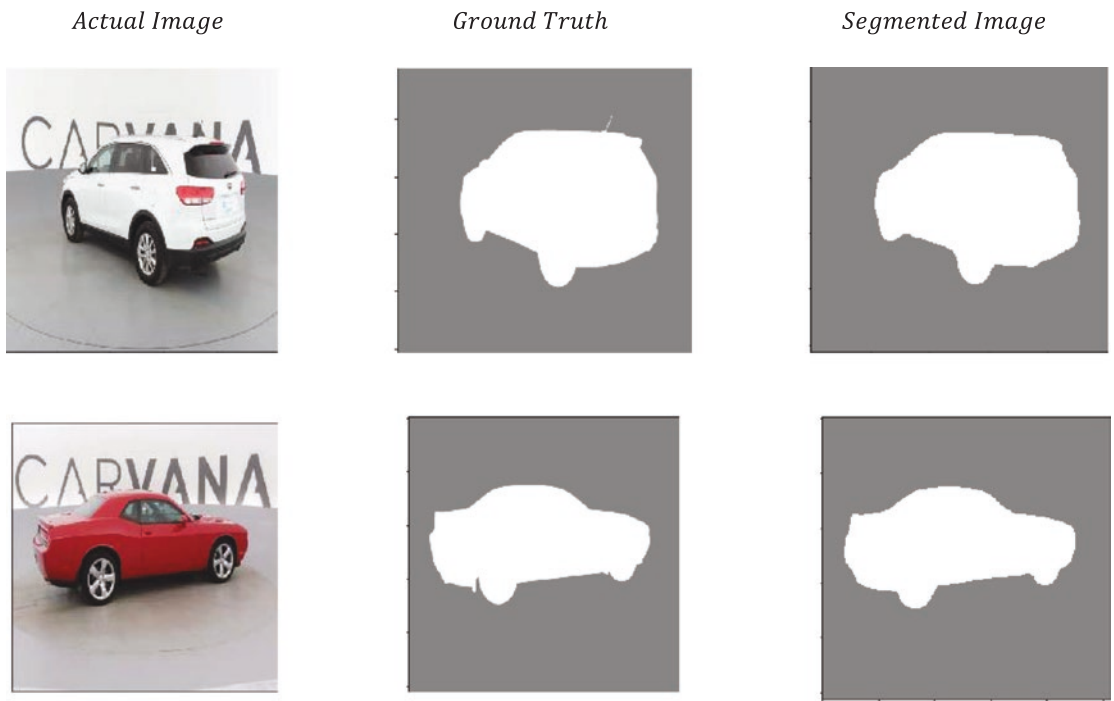

Figure 6-15b. Segmentation results from the validation dataset with model trained on 512×512 -size images

Image Classification and Localization Network

All the classification models predict the class of the object in the image but don't really tell us the location of the object. A bounding box can be used to represent the location of the object in the image. If the images are annotated with bounding boxes and information about them is available with the output class, it would be possible to train the model to predict these bounding boxes along with the class of the object. These bounding boxes can be represented by four numbers, two corresponding to the spatial coordinates of the leftmost upper part of the bounding box and the other two to denote the height and width of the bounding box. Then, these four numbers can be predicted by regression. One can use one convolutional neural network for classification and another for predicting these bounding-box attributes through regression. However, generally the same convolutional neural network is used for predicting the class of the object as well as for predicting the bounding-box location. The CNN up to the last fully connected dense layers would be the same, but in the output, along with the different classes for objects, there would be four extra units corresponding to the bounding-box attributes. This technique of predicting bounding boxes around objects within an image is known as *localization*. Illustrated in Figure 6-16 is an image classification and localization network pertaining to images of dogs and cats. The *Apriori* assumption in this type of neural network is that there is only one class object in an image.

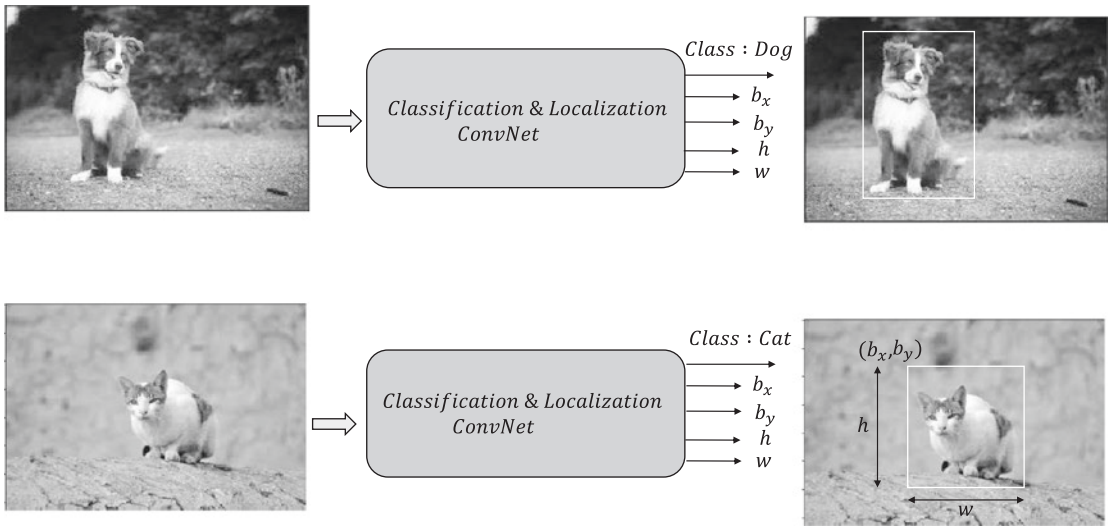

Figure 6-16. Classification and localization network

The cost function for this network would be a combination of classification loss/cost over the different object classes and the regression cost associated with the prediction of the bounding-box attributes. Since the cost to optimize is a multi-task objective function, one needs to determine how much weight to assign to each task. This is important since the different costs associated with these tasks—let’s say categorical cross-entropy for classification and RMSE for regression—would have different scales and hence could drive the optimization haywire if the costs are not weighed properly to form the total cost. The costs need to be normalized to a common scale and then assigned weights based on the complexity of the tasks. Let the parameters of the convolutional neural network that deals with n classes and a bounding box determined by the four numbers be represented by θ . Let the output class be represented by the vector $y = [y_1, y_2 \dots y_n]^T \in \{0,1\}^{n \times 1}$ since each of the $y_j \in \{0,1\}$. Also, let the bounding-box numbers be represented by the vector $s = [s_1, s_2, s_3, s_4]^T$ where s_1 and s_2 denote bounding-box coordinates for the upper leftmost pixel while s_3 and s_4 denote the height and width of the bounding box. If the predicted probabilities of the classes are represented by $p = [p_1, p_2 \dots p_n]^T$ while the predicted bounding-box attributes are represented by $t = [t_1, t_2, t_3, t_4]^T$, then the loss or cost function associated with an image can be expressed as

$$c(\theta) = -\alpha \sum_{j=1}^n y_j \log p_j + \beta \sum_{j=1}^4 (s_j - t_j)^2$$

The first term in the preceding expression denotes categorical cross-entropy for the SoftMax over the n classes while the second term is the regression cost associated with predicting the bounding-box attributes. The parameters α and β are the hyper-parameters of the network and should be fine-tuned for obtaining reasonable results. For a mini batch over m data points the cost function can be expressed as follows:

$$C(\theta) = \frac{1}{m} \left[-\alpha \sum_{i=1}^m \sum_{j=1}^n y_j^{(i)} \log p_j^{(i)} + \beta \sum_{i=1}^m \sum_{j=1}^4 (s_j^{(i)} - t_j^{(i)})^2 \right]$$

where the suffix over i represents different images. The preceding cost function can be minimized through gradient descent. Just as an aside, when comparing the performance of different versions of this network with different hyper-parameter values for (α, β) , one should not compare the cost associated with these networks as criteria for selecting the best network. Rather, one should use some other metrics such as precision, recall, F1-score, area under the curve, and so on for the classification task and metrics such as overlap area of the predicted and the ground truth bounding boxes, and so on for the localization task.

Object Detection

An image in general doesn't contain one object but several objects of interest. There are a lot of applications that benefit from being able to detect multiple objects in images. For example, object detection can be used to count the number of people in several areas of a store for crowd analytics. Also, at an instant the traffic load on a signal can be detected by getting a rough estimate of the number of cars passing through the signal. Another area in which object detection is being leveraged is in the automated supervision of industrial plants to detect events and generate alarms in case there has been a safety violation. Continuous images can be captured in critical areas of the plant that are hazardous and critical events can be captured from those images based on multiple objects detected within the image. For instance, if a worker is working with machinery that requires him to wear safety gloves, eye glasses, and helmet, a safety violation can be captured based on whether the objects mentioned were detected in the image or not.

The task of detecting multiple objects in images is a classical problem in computer vision. To begin with, we cannot use the classification and localization network or any variants of it since images can have varying numbers of objects within them. To get ourselves motivated toward solving the problem of object detection, let's get started with a very naïve approach. We can randomly take image patches from the existing image by a brute-force sliding-window technique and then feed it to a pre-trained object classification and localization network. Illustrated in Figure 6-17 is a sliding-window approach to detecting multiple objects within an image.

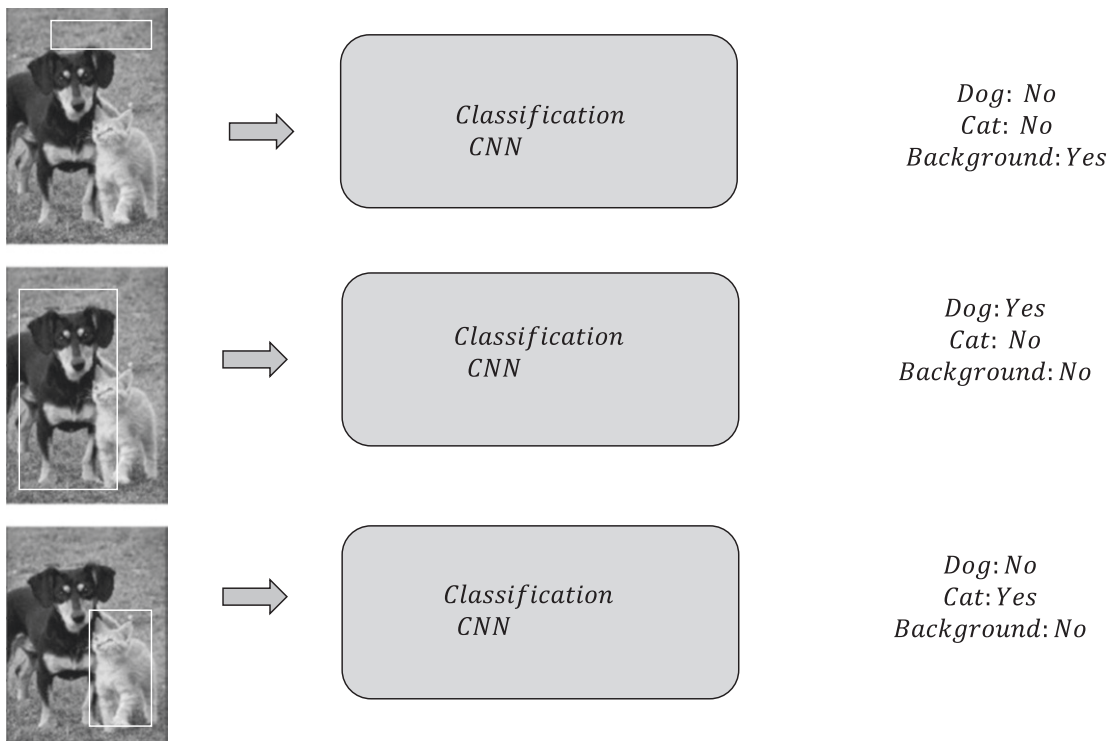

Figure 6-17. Sliding-window technique to object detection

Although this method would work, it would be computationally very expensive, or rather computationally intractable, since one would have to try thousands of image patches at different locations and scales in the absence of good region proposals. The current advanced methods in object detection propose several regions in which objects can be located and then feeds those image-proposal regions to the classification and localization network. One such object-detection technique is called R-CNN, which we will discuss next.

R-CNN

In an R-CNN, *R* stands for *region* proposals. The region proposals are usually derived in through an algorithm called *selective search*. A selective search on an image generally provides around 2000 region proposals of interest. Selective search usually utilizes traditional image-processing techniques to locate blobby regions in an image as prospective areas likely to contain objects. The following are the processing steps for selective search on a broad level:

- Generate many regions within the image, each of which can belong to only one class.
- Recursively combine smaller regions into larger ones through a greedy approach. At each step, the two regions merged should be most similar. This process needs to be repeated until only one region remains. This process yields a hierarchy of successively larger regions and allows the algorithm to propose a wide variety of likely regions for object detection. These generated regions are used as the candidate region proposals.

These 2000 regions of interest are then fed to the classification and localization network to predict the class of the object along with associated bounding boxes. The classification network is a convolutional neural network followed by a support-vector machine for the final classification. Illustrated in Figure 6-18 is a high-level architecture for an R-CNN.

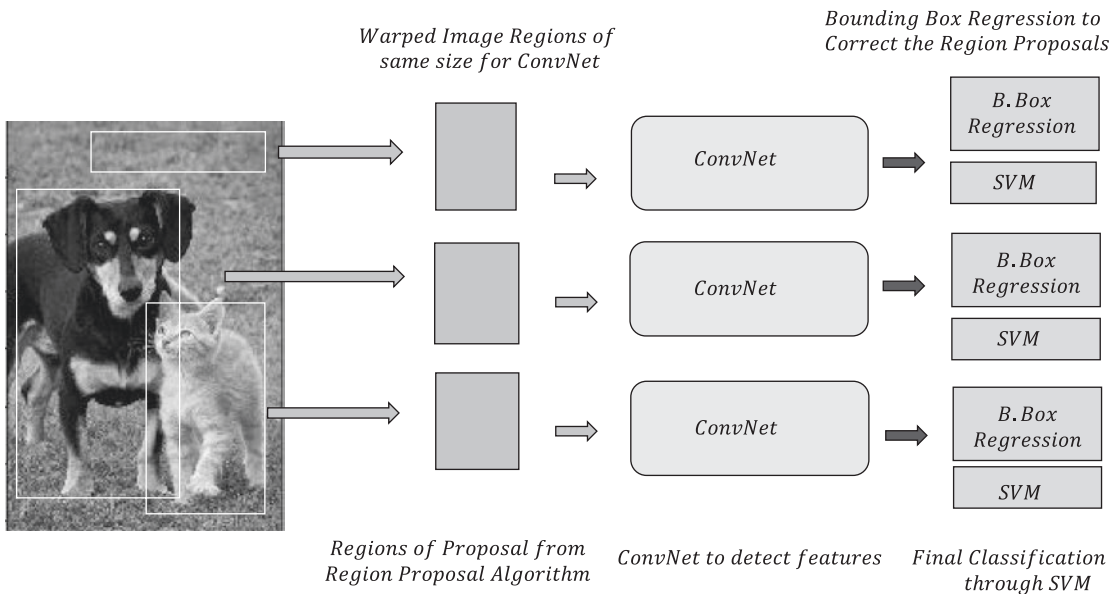

Figure 6-18. R-CNN network

The following are the high-level steps associated with training an R-CNN:

- Take a pre-trained ImageNet CNN such as AlexNet and retrain the last fully connected layer with the objects that need to be detected, along with backgrounds.
- Get all the region proposals per image (2000 per image as per selective search), warp or resize them to match the CNN input size, process them through CNN, and then save the features on disk for further processing. Generally, the pooling layer output maps are saved as features to disk.
- Train SVM to classify either object or background based on the features from CNN. For each class of objects there should be one SVM that learns to distinguish between the specific object and background.
- Finally, bounding-box regression is done to correct the region proposals.

Although the R-CNN does a good job in at object detection, the following are some of its drawbacks:

- One of the problems with R-CNN is the huge number of proposals, which makes the network very slow since each of these 2000 proposals would have independent flows through convolution neural networks. Also, the region proposals are fixed; the R-CNN is not learning them.
- The localization and bounding boxes predicted are from separate models and hence during model training we are not learning anything specific to localization of the objects based on the training data.
- For the classification task, the features generated out of the convolutional neural network are used to fine-tune SVMs, leading to a higher processing cost.

Fast and Faster R-CNN

Fast R-CNN overcomes some of the computational challenges of R-CNN by having a common convolution path for the whole image up to a certain number of layers, at which point the region proposals are projected to the output feature maps and relevant regions are extracted for further processing through fully connected layers and then the final classification. The extraction of relevant region proposals from the output feature maps from convolution and resizing of them to a fixed size for the fully connected layer is done through a pooling operation known as ROI pooling. Illustrated in Figure 6-19 is an architecture diagram for Fast R-CNN.

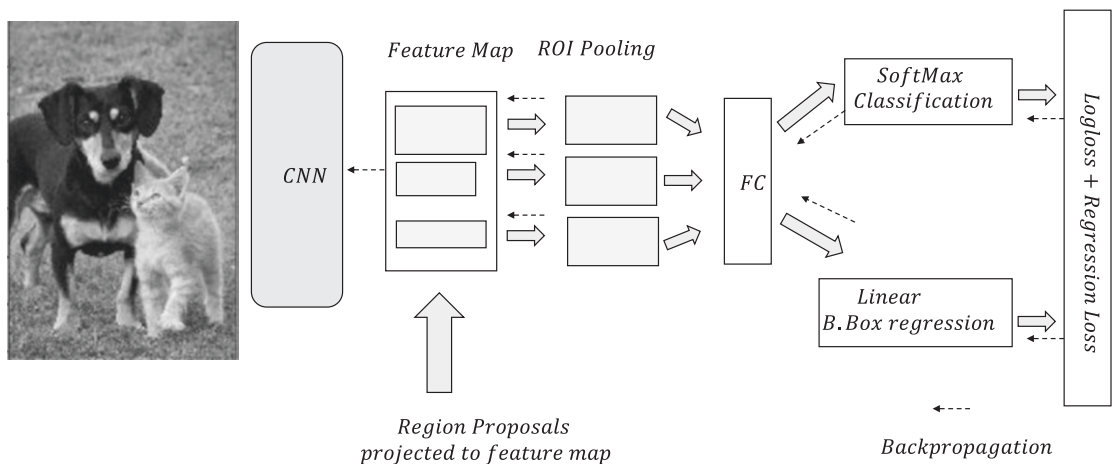

Figure 6-19. Fast R-CNN schematic diagram

Fast R-CNN saves a lot of costs associated with multiple convolution operations (2000 per image per selective search) in R-CNN. However, the region proposals are still dependent on the external region-proposal algorithms such as selective search. Because of this dependency on external region-proposal algorithms, Fast R-CNN is bottlenecked by the computation of these region proposals. The network must wait for these external proposals to be made before it can move forward. These bottleneck issues are eliminated by Faster R-CNN, where the region proposals are done within the network itself instead of depending on external algorithms. The architecture diagram for Faster R-CNN is almost like that of Fast R-CNN, but with a new addition—a region-proposal network that eliminates the dependency on an external region-proposal scheme such as selective search.

Generative Adversarial Networks

Generative adversarial networks, or GANs, are one of the biggest advances in deep learning in recent times. Ian Goodfellow and colleagues first introduced this network in 2014 in an NIPS paper titled “Generative Adversarial Networks.” The paper can be located at <https://arxiv.org/abs/1406.2661>. Since then, there has been a lot of interest and development in generative adversarial networks. In fact, Yann LeCun, one of the most prominent deep-learning experts, considers the introduction of generative adversarial networks to be the most important breakthrough in deep learning in recent times. GANs are used as generative models for producing synthetic data like the data produced by a given distribution. GAN has usages and potential in several fields, such as image generation, image inpainting, abstract reasoning, semantic segmentation, video generation, style transfer from one domain to another, and text-to-image generation applications, among others.

Generative adversarial networks are based on the two agents zero-sum game from game theory. A generative adversarial network has two neural networks, the generator (G) and the discriminator (D), competing against each other. The generator (G) tries to fool the discriminator (D) such that the discriminator is not able to distinguish between real data from a distribution and the fake data generated by the generator (G). Similarly, the discriminator (D) learns to distinguish the real data from the fake data generated by the generator (G). Over a certain period, both the discriminator and the generator improve on their own tasks while competing with each other. The optimal solution to this game-theory problem is given by the Nash equilibrium wherein the generator learns to produce fake data that has a distribution the same as that of the original data distribution, and at the same time the discriminator outputs $\frac{1}{2}$ probability for both real and fake data points.

Now, the most obvious question is how are the fake data constructed. The fake data is constructed through the generative neural network model (G) by sampling noise z from a prior distribution P_z . If the actual data x follows distribution P_x and the fake data $G(z)$ generated by the generator follows distribution P_g , then at equilibrium $P_x(x)$ should equal $P_g(G(z))$; i.e.,

$$P_g(G(z)) \sim P_x(x)$$

Since at equilibrium the distribution of the fake data would be almost the same as the real data distribution, the generator would learn to sample fake data that would be hard to distinguish from the real data. Also, at equilibrium the discriminator D should output $\frac{1}{2}$ as the probability for both classes—the real data and the fake data. Before we go through the math for a generative adversarial network, it is worthwhile to gain some understanding about the zero-sum game, Nash equilibrium, and Minimax formulation.

Illustrated in Figure 6-20 is a generative adversarial network in which there are two neural networks, the generator (G) and the discriminator (D), that compete against each other.

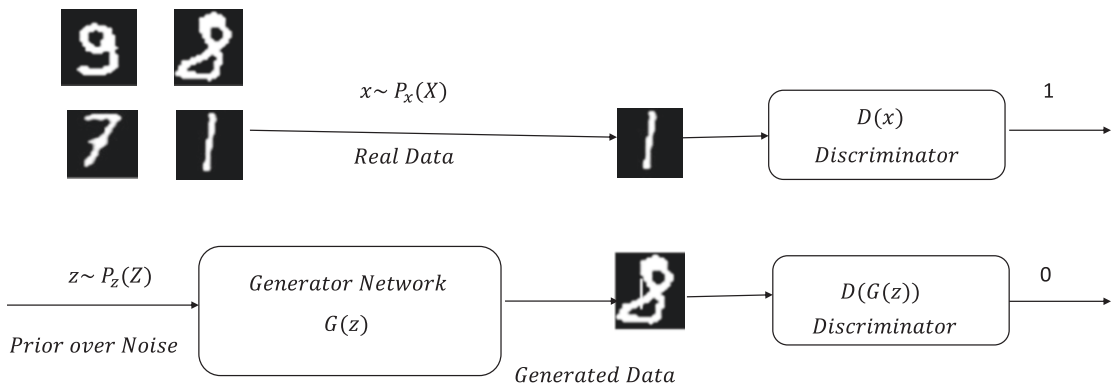

Figure 6-20. Basic illustration of adversarial network

Maximin and Minimax Problem

In a game between participants, each one would try to maximize their payoff and enhance their chance of winning. Considering a game played by N competitors, the maximin strategy of candidate i is the one that maximizes his or her payoff given the other $N-1$ participants are playing to take candidate i down. The payoff of candidate i corresponding to the maximin strategy is the maximum value the candidate i is sure to get without knowing the others' moves. Hence, the maximin strategy s_i^* and the maximin value L_i^* can be expressed as

$$s_i^* = \underbrace{\operatorname{argmax}}_{s_i} \underbrace{\min}_{s_{-i}} L_i(s_i, s_{-i})$$

$$L_i^* = \underbrace{\max}_{s_i} \underbrace{\min}_{s_{-i}} L_i(s_i, s_{-i})$$

An easy way to interpret the maximin strategy for candidate i is to consider that i already has knowledge of his opponents' moves and that they would try to minimize his maximum payoff possible in each of his moves. Hence, with this assumption, i will play a move that would be the maximum of all the minima in each of his moves.

It is easier to explain minimax strategy in this paradigm instead of in its more technical terms. In minimax strategy, the candidate i would assume that the other candidates denoted by $-i$ would allow the minimum in each of their moves. In such a case, it is logical for i to select a move that would provide him the maximum of all the minimum payoffs that other candidates have set for i in each of their moves. Under the minimax strategy, candidate i 's payoff is given by

$$L_i^* = \underbrace{\min}_{s_{-i}} \underbrace{\max}_{s_i} L_i(s_i, s_{-i})$$

Do note that the final payoffs or losses when all the players have made their moves might be different from the maximin or minimax values.

Let us try to motivate a maximin problem with an intuitive example in which two agents *A* and *B* are competing against each other to maximize their profit from the game. Also, let's assume that *A* can make three moves, L_1, L_2, L_3 , while *B* can make two moves, M_1 and M_2 . The payoff table for this is shown in Figure 6-21. In each cell, the first entry corresponds to *A*'s payoff while the second entry denotes *B*'s payoff.

		<i>B</i>	
		M_1	M_2
<i>A</i>	L_1	(6,2)	(4, -41)
	L_2	(10,0.5)	(-20.5,2)
	L_3	(-201,4.1)	(8,8)

Figure 6-21. Maximin and minimax illustration between two players

Let us first assume that both *A* and *B* are playing maximin strategy; that is, they should make a move to maximize their payoffs with the expectation that the other is going to minimize their payoff as much as possible.

A's maximin strategy would be to select move L_1 , in which case the minimum *A* would get is 4. If he chooses L_2 , *A* runs the risk of ending up with -20, while if he chooses L_3 he may end up with even worse at -201. So, the maximin value for *A* is the maximum of all the minimums possible in each row; i.e., 4, corresponding to the strategy L_1 .

B's maximin strategy would be to select M_1 since along M_1 the minimum *B* would get is 0.5. If *B* chooses M_2 , then *B* runs the risk of ending up with -41. So, the minimax value for *B* is the maximum of all the possible minimums along the columns; i.e., 0.5, corresponding to M_1 .

Now, let's say both *A* and *B* play their minimax strategy, i.e., (L_1, M_1) , in which case *A*'s payoff is 6 and that of *B* is 2. So, we see that the maximin values are different from the actual payoff values once the players play their maximin strategies.

Now, let's look at the situation where both players wish to play minimax strategy. In minimax strategy, one selects a strategy to arrive at a maximum that is the minimum of all the possible maxima in each of the opponent's moves.

Let's look at *A*'s minimax value and strategy. If *B* selects M_1 , the maximum *A* can get is 10, while if *B* selects M_2 the maximum *A* can get is 8. Obviously, *B* would allow *A* to take only the minimum of each of the maxima possible in each of *B*'s moves, and so, thinking of *B*'s mindset, the minimax value that *A* can expect is 8, corresponding to his move L_2 .

Similarly, *B*'s minimax value would be the minimum of all the maxima possible for *B* in each of *A*'s moves; i.e., minima of 2, and 8. Hence, *B*'s minimax value is 2.

One thing to notice is that the minimax value is always larger than rather than equal to the maximin value for a candidate solely because of how the maximin and minimax are defined.

Zero-sum Game

In game theory, a zero-sum game is a mathematical formulation of a situation in which every participant's gain or loss is equally offset by other participants' loss or gain. So, as a system, the net gain or loss of the group of participants is zero. Consider a zero-sum game played by two players *A* and *B* against each other. The zero-sum game can be represented by a structure called a payoff matrix, as shown in Figure 6-22.

		<i>B</i>		
		M_1	M_2	M_3
<i>A</i>	L_1	4	-2	-6
	L_2	0	-10	12
	L_3	8	6	10

Figure 6-22. Payoff matrix for a two-player zero-sum game

Figure 6-22 is an illustration of the two-player payoff matrix where each cell in the matrix represents the payoff of player *A*'s game for every combination of moves for *A* and *B*. Since this is a zero-sum game, the payoff of *B* is not explicitly mentioned; it's just the negative of the payoff of player *A*. Let's say *A* plays a maximin game. It would choose the maximum of the minima in each row and hence would select strategy L_3 with its corresponding payoff of the maximum of $\{-2, -10, 6\}$; i.e., 6. The payoff of 6 corresponds to the move M_2 for *B*. Similarly, had *A* played the minimax strategy, *A* would have been forced to get a payoff equal to the minimum of the maxima of the payoffs along each column; i.e., for each of *B*'s moves. In that case, *A*'s payoff would have been the minimum of $\{8, 6, 10\}$, i.e., 6, corresponding to the minimax strategy of L_3 . Again, this payoff of 6 corresponds to move M_2 for *B*. So, we can see in the case of a zero-sum game the maximin payoff of a participant is equal to the minimax payoff.

Now, let's look at the maximin payoff of player *B*. The maximin payoff of *B* is the maximum of the minima of *B* in each move; i.e., the maximum of $(-8, -6, -12) = -6$, which corresponds to the move M_2 . Also, this value corresponds to the move L_3 for *A*. Similarly, the minimax payoff of *B* is the minimum of the maxima *B* can have for each of *A*'s moves; i.e., $(6, 10, -6) = -6$. Again, for *B* the minimax value is the same as the maximin value and the corresponding move for *B* is M_2 . The corresponding move for *A* in this scenario is also L_3 .

So, the learnings from a zero-sum game are as follows:

- Irrespective of whether *A* and *B* play maximin strategy or minimax strategy they are going to end up with the moves L_3 and M_2 respectively, corresponding to payoffs of 6 for *A* and -6 for *B*. Also, the minimax and maximin values for the players coincided with the actual payoff values the player got when they went with the minimax strategy.
- The preceding point leads to one important fact: in a zero-sum game the minimax strategy for one player would yield the actual strategies for both players had they both employed pure minimax or maximin strategies. Hence, both the moves can be determined by considering the moves of either *A* or *B*. If we consider *A*'s minimax strategy, then both the players' moves are embedded in it. If the payoff utility of *A* is $U(S_1, S_2)$ then the moves of *A* and *B*—i.e., S_1 and S_2 respectively—can be found out by applying the minimax strategy of *A* or *B* alone.

Minimax and Saddle Points

For zero-sum minimax problems involving two players A and B , the payoff $U(x,y)$ of player A can be expressed as

$$\hat{U} = \min_y \max_x U(x,y)$$

where x denotes the move of A while y denotes the move of B .

Also, the values of x,y corresponding to \hat{U} are the equilibrium strategies of A and B respectively; i.e., they would not change the move if they continue to believe in the minimax or the maximin strategy. For a zero-sum two-player game, minimax or maximin would yield the same results, and hence this equilibrium holds true if the players are playing with either the minimax or the maximin strategy. Also, since the minimax value is equal to the maximin value, the order in which the minimax or maximin are defined doesn't matter. We might just as well let A and B independently select their best strategies for each strategy of the other, and we will see that for a zero-sum game one of the combinations of strategies will overlap. This overlapping condition is the best strategy for both A and B and is identical to their minimax strategy. This is also the Nash Equilibrium for the game.

Up to now we have kept the strategies discrete for easy interpretability using the payoff matrix, but they can be of continuous values. As for the GAN, the strategies are the continuous parameter values of the generator and the discriminator neural networks, and so before we go into the details of the GAN utility function it makes sense to look at the payoff utility function $f(x,y)$ for A , which is a function of two continuous variables in x and y . Further, let x be the move of A and y be the move of B . We need to find the equilibrium point, which is also the minimax or the maximin of the payoff utility function of either player. The payoff corresponding to the minimax of A would provide the strategy of both A and B . Since for the zero-sum two-player game the minimax and maximin are the same, the order of minimax doesn't matter; i.e.,

$$\min_y \max_x f(x,y) = \max_x \min_y f(x,y) = \min_y \max_x f(x,y)$$

For a continuous function this is only possible when the solution to the preceding function is a saddle point. A saddle point is a point at which the gradient with respect to each of the variables is zero; however, it is not a local minima or maxima. Instead, it tends to a local minimum in some directions of input vector and a local maximum with respect to the other directions of input vector. So, one can just use the methods of finding a saddle point using multi-variate calculus. Without loss of generality for a multi-variate function $f(x)$ with $\forall x \in \mathbb{R}^{n \times 1}$ we can determine the saddle point by the following test:

- Compute the gradient of $f(x)$ with respect to the vector x , i.e., $\nabla_x f(x)$, and set it to zero.
- Evaluate the Hessian $\nabla_x^2 f(x)$ of the function i.e. the matrix of second order derivatives at each of the points at which the gradient vector $\nabla_x f(x)$ is zero. If the Hessian Matrix has both positive and negative Eigen values at the evaluated point then the point is a saddle point.

Coming back to the two-variable payoff utility function $f(x,y)$, for A let us define it as follows to illustrate an example:

$$f(x,y) = x^2 - y^2$$

Hence, the utility function for B would automatically be $-x^2 + y^2$.

We now investigate whether the utility function provides for an equilibrium if both players play a zero-sum minimax or maximin strategy. The game would have an equilibrium beyond which the players won't be able to improve their payoffs due to their strategies' being optimal if the function $f(x, y)$ has a saddle point. The equilibrium condition is the Nash Equilibrium of the game.

Setting the gradient of $f(x, y)$ to zero we get

$$\nabla f(x, y) = \begin{bmatrix} \frac{\partial f}{\partial x} \\ \frac{\partial f}{\partial y} \end{bmatrix} = \begin{bmatrix} 2x \\ -2y \end{bmatrix} = 0 \Rightarrow (x, y) = (0, 0)$$

The Hessian of the function is given by

$$\nabla^2 f(x, y) = \begin{bmatrix} \frac{\partial^2 f}{\partial x^2} & \frac{\partial^2 f}{\partial x \partial y} \\ \frac{\partial^2 f}{\partial y \partial x} & \frac{\partial^2 f}{\partial y^2} \end{bmatrix} = \begin{bmatrix} 2 & 0 \\ 0 & -2 \end{bmatrix}$$

The Hessian of the function is $\begin{bmatrix} 2 & 0 \\ 0 & -2 \end{bmatrix}$ for any value of (x, y) including $(x, y) = (0, 0)$. Since the Hessian has

both positive and negative Eigen values i.e. 2 and -2 , hence the point $(x, y) = (0, 0)$ is a saddle point. The strategies at equilibrium for A should be to set $x = 0$ while that of y should be to set $y = 0$ in a zero-sum minimax or maximin game.

GAN Cost Function and Training

In generative adversarial networks, both the generator and the discriminator networks try to outdo each other by playing the minimax strategy in a zero-sum game. The moves in this case are parameter values that the networks choose. For ease of notation, to begin with let us represent the model parameters by the model notations themselves; i.e., G for the generator and D for the discriminator. Now, let's frame the utility of the payoff function for each of the networks. The discriminator would try to classify both the fake or synthetically generated samples and the real data samples correctly. In other words, it would try to maximize the utility function

$$U(D, G) = E_{x \sim P_x(x)} [\log D(x)] + E_{z \sim P_z(z)} [\log(1 - D(G(z)))]$$

where x denotes the real data samples drawn from the probability distribution $P_x(x)$ and z is the noise drawn from a prior noise distribution $P_z(z)$. Also, the discriminator is trying to output 1 for real data sample x and 0 for generator-created fake or synthetic data based on the noise samples z . Hence, the discriminator would like to play a strategy that maximizes $D(x)$ to be as close as possible to 1, which would make $\log D(x)$ near a 0 value. The more $D(x)$ is less than 1 the smaller the value for $\log D(x)$ would be and hence the smaller the utility value for the discriminator would be. Similarly, the discriminator would like to catch the fake or

synthetic data by setting its probability close to zero; i.e., set $D(G(z))$ as close to zero as possible to identify it as a fake image. When $D(G(z))$ is near zero, the expression $\left[\log(1-D(G(z)))\right]$ tends to zero. As the value of $D(G(z))$ diverges from zero, the payoff for the discriminator becomes smaller since $\log(1-D(G(z)))$ gets smaller. The discriminator would like to do it over the whole distribution of x and z , and hence the terms for expectation or mean in its payoff function. Of course, the generator G has a say in the payoff function for D in the form of $G(z)$ —i.e., the second term—and so it would also try to play a move that minimizes the payoff for D . The more the payoff for D is, the worse the situation is for G . So, we can think of G as having the same utility function as D has, only with a negative sign in it, which makes this a zero-sum game where the payoff for G is given by

$$V(D, G) = -E_{x \sim P_x(x)}[\log D(x)] - E_{z \sim P_z(z)}[\log(1 - D(G(z)))]$$

The generator G would try to choose its parameters so that $V(D, G)$ is maximized; i.e., it produces fake data samples $G(z)$ such that the discriminator is fooled into classifying them with a 0 label. In other words, it wants the discriminator to think $G(z)$ is real data and assign high probability to them. High values of $D(G(z))$ away from 0 would make $\log(1 - D(G(z)))$ a negative value with a high magnitude, and when multiplied by the negative sign at the beginning of the expression it would produce a high value of $-E_{z \sim P_z(z)}[\log(1 - D(G(z)))]$, thus increasing the generator’s payoff. Unfortunately, the generator would not be able to influence the first term in $V(D, G)$ involving real data since it doesn’t involve the parameters in G .

The generator G and the discriminator D models are trained by letting them play the zero-sum game with the minimax strategy. The discriminator would try to maximize its payoff $U(D, G)$ and would try to reach its minimax value.

$$u^* = \min_D \max_G E_{x \sim P_x(x)}[\log D(x)] + E_{z \sim P_z(z)}[\log(1 - D(G(z)))]$$

Similarly, the generator G would like to maximize its payoff $V(D, G)$ by selecting a strategy.

$$v^* = \min_D \max_G -E_{x \sim P_x(x)}[\log D(x)] - E_{z \sim P_z(z)}[\log(1 - D(G(z)))]$$

Since the first term is something that is not in the control of G to maximize,

$$v^* = \min_D \max_G -E_{z \sim P_z(z)}[\log(1 - D(G(z)))]$$

As we have seen, in a zero-sum game of two players one need not consider separate minimax strategies, as both can be derived by considering the minimax strategy of one of the players’ payoff utility functions. Considering the minimax formulation of the discriminator, we get the discriminator’s payoff at equilibrium (or Nash Equilibrium) as

$$u^* = \min_G E_{x \sim P_x(x)}[\log D(x)] + E_{z \sim P_z(z)}[\log(1 - D(G(z)))]$$

The values of \hat{G} and \hat{D} at u^* would be the optimized parameters for both networks beyond which they can't improve their scores. Also (\hat{G}, \hat{D}) gives the saddle point of D 's utility function

$$E_{x \sim P_x(x)}[\log D(x)] + E_{z \sim P_z(z)}[\log(1 - D(G(z)))]$$

The preceding formulation can be simplified by breaking down the optimization in two parts; i.e., let D maximize its payoff utility function with respect to its parameters and let G minimize D 's payoff utility function with respect to its parameters in each move.

$$\max_D E_{x \sim P_x(x)}[\log D(x)] + E_{z \sim P_z(z)}[\log(1 - D(G(z)))]$$

$$\min_G E_{z \sim P_z(z)}[\log(1 - D(G(z)))]$$

Each would consider the other's move as fixed while optimizing its own cost function. This iterative way of optimization is nothing but the gradient-descent technique for computing the saddle point. Since machine-learning packages are mostly coded to minimize rather than maximize, the discriminator's objective can be multiplied by -1 and then D can minimize it rather than maximizing it.

Presented next is the mini-batch approach generally used for training the GAN based on the preceding heuristics:

- for N number of epochs:
- for k steps:
 - Draw m samples $\{z^{(1)}, z^{(2)}, \dots, z^{(m)}\}$ from the noise distribution $z \sim P_z(z)$
 - Draw m samples $\{x^{(1)}, x^{(2)}, \dots, x^{(m)}\}$ from the data distribution $x \sim P_x(x)$
 - Update the discriminator D parameters by using stochastic gradient descent. If the parameters of the discriminator D are represented by θ_D , then update θ_D as

$$\theta_D \rightarrow \theta_D - \nabla_{\theta_D} \left[-\frac{1}{m} \sum_{i=1}^m (\log D(x^{(i)})) + \log(1 - D(G(z^{(i)}))) \right]$$

- end
 - Draw m samples $\{z^{(1)}, z^{(2)}, \dots, z^{(m)}\}$ from the noise distribution $z \sim P_z(z)$
 - Update the generator G by stochastic gradient descent. If the parameters of the generator G are represented by θ_G , then update θ_G as

$$\theta_G \rightarrow \theta_G - \nabla_{\theta_G} \left[\frac{1}{m} \sum_{i=1}^m \log(1 - D(G(z^{(i)}))) \right]$$

- end

Vanishing Gradient for the Generator

Generally, in the initial part of training the samples produced by the generator are very different from the original data and hence the discriminator can easily tag them as fake. This leads to close-to-zero values for

$D(G(z))$, and so the gradient $\nabla_{\theta_G} \left[\frac{1}{m} \sum_{i=1}^m \log(1 - D(G(z^{(i)}))) \right]$ saturates, leading to a vanishing-gradient

problem for parameters of the network of G . To overcome this problem, instead of minimizing

$E_{z \sim p_z} \left[\log(1 - D(G(z))) \right]$, the function $E_{z \sim p_z} \left[\log G(z) \right]$ is maximized or, to adhere to gradient descent,

$E_{z \sim p_z} \left[-\log G(z) \right]$ is minimized. This alteration makes the training method no longer a pure minimax game

but seems to be a reasonable approximation that helps overcome saturation in the early phase of training.

TensorFlow Implementation of a GAN Network

In this section, a GAN network trained on MNIST images is illustrated where the generator tries to create fake synthetic images like MNIST while the discriminator tries to tag those synthetic images as fake while still being able to distinguish the real data as authentic. Once the training is completed, we sample a few synthetic images and see whether they look like the real ones. The generator is a simple feed-forward neural network with three hidden layers followed by the output layer, which consists of 784 units corresponding to the 784 pixels in the MNIST image. The activations of the output unit have been taken to be *tanh* instead of *sigmoid* since *tanh* activation units suffer less from vanishing-gradient problems as compared to sigmoid units. A *tanh* activation function outputs values between -1 and 1 and thus the real MNIST images are normalized to have values between -1 and 1 so that both the synthetic images and the real MNIST images operate in the same range. The discriminator network is also a three-hidden-layer feed forward neural network with a sigmoid output unit to perform binary classification between the real MNIST images and the synthetic ones produced by the generator. The input to the generator is a 100-dimensional input sampled from a uniform noise distribution operating between -1 and 1 for each dimension. The detailed implementation is illustrated in Listing 6-5.

Listing 6-5. Implementation of a Generative Adversarial Network

```
import tensorflow as tf
from tensorflow.examples.tutorials.mnist import input_data
import numpy as np
import matplotlib.pyplot as plt
%matplotlib inline

## The dimension of the Prior Noise Signal is taken to be 100
## The generator would have 150 and 300 hidden units successively before 784 outputs
## corresponding
## to 28x28 image size

h1_dim = 150
h2_dim = 300
dim = 100
batch_size = 256
```



```

#-----
# Define the generator - take noise and convert them to images
#-----
def generator_(z_noise):
    w1 = tf.Variable(tf.truncated_normal([dim,h1_dim], stddev=0.1), name="w1_g", dtype=tf.
float32)
    b1 = tf.Variable(tf.zeros([h1_dim]), name="b1_g", dtype=tf.float32)
    h1 = tf.nn.relu(tf.matmul(z_noise, w1) + b1)
    w2 = tf.Variable(tf.truncated_normal([h1_dim,h2_dim], stddev=0.1), name="w2_g",
dtype=tf.float32)
    b2 = tf.Variable(tf.zeros([h2_dim]), name="b2_g", dtype=tf.float32)
    h2 = tf.nn.relu(tf.matmul(h1, w2) + b2)
    w3 = tf.Variable(tf.truncated_normal([h2_dim,28*28],stddev=0.1), name="w3_g", dtype=tf.
float32)
    b3 = tf.Variable(tf.zeros([28*28]), name="b3_g", dtype=tf.float32)
    h3 = tf.matmul(h2, w3) + b3
    out_gen = tf.nn.tanh(h3)
    weights_g = [w1, b1, w2, b2, w3, b3]
    return out_gen,weights_g

#-----
# Define the Discriminator - take both real images and synthetic fake images
# from Generator and classify the real and fake images properly
#-----
def discriminator_(x,out_gen,keep_prob):
    x_all = tf.concat([x,out_gen], 0)
    w1 = tf.Variable(tf.truncated_normal([28*28, h2_dim], stddev=0.1), name="w1_d",
dtype=tf.float32)
    b1 = tf.Variable(tf.zeros([h2_dim]), name="b1_d", dtype=tf.float32)
    h1 = tf.nn.dropout(tf.nn.relu(tf.matmul(x_all, w1) + b1), keep_prob)
    w2 = tf.Variable(tf.truncated_normal([h2_dim, h1_dim], stddev=0.1), name="w2_d",
dtype=tf.float32)
    b2 = tf.Variable(tf.zeros([h1_dim]), name="b2_d", dtype=tf.float32)
    h2 = tf.nn.dropout(tf.nn.relu(tf.matmul(h1,w2) + b2), keep_prob)
    w3 = tf.Variable(tf.truncated_normal([h1_dim, 1], stddev=0.1), name="w3_d", dtype=tf.
float32)
    b3 = tf.Variable(tf.zeros([1]), name="d_b3", dtype=tf.float32)
    h3 = tf.matmul(h2, w3) + b3
    y_data = tf.nn.sigmoid(tf.slice(h3, [0, 0], [batch_size, -1], name=None))
    y_fake = tf.nn.sigmoid(tf.slice(h3, [batch_size, 0], [-1, -1], name=None))
    weights_d = [w1, b1, w2, b2, w3, b3]
    return y_data,y_fake,weights_d

```

```

#-----
# Read the MNIST dataset
#-----
mnist = input_data.read_data_sets('MNIST_data', one_hot=True)
#-----
# Define the different Tensorflow ops and variables, cost function, and Optimizer
#-----
# Placeholders
x = tf.placeholder(tf.float32, [batch_size, 28*28], name="x_data")
z_noise = tf.placeholder(tf.float32, [batch_size,dim], name="z_prior")
#Dropout probability
keep_prob = tf.placeholder(tf.float32, name="keep_prob")
# generate the output ops for generator and also define the weights.
out_gen,weights_g = generator_(z_noise)
# Define the ops and weights for Discriminator
y_data, y_fake,weights_d = discriminator_(x,out_gen,keep_prob)
# Cost function for Discriminator and Generator
discr_loss = - (tf.log(y_data) + tf.log(1 - y_fake))
gen_loss = - tf.log(y_fake)
optimizer = tf.train.AdamOptimizer(0.0001)
d_trainer = optimizer.minimize(discr_loss,var_list=weights_d)
g_trainer = optimizer.minimize(gen_loss,var_list=weights_g)
init = tf.global_variables_initializer()
saver = tf.train.Saver()

#-----
# Invoke the TensorFlow graph and begin the training
#-----

sess = tf.Session()
sess.run(init)
z_sample = np.random.uniform(-1, 1, size=(batch_size,dim)).astype(np.float32)

for i in range(60000):
    batch_x, _ = mnist.train.next_batch(batch_size)
    x_value = 2*batch_x.astype(np.float32) - 1
    z_value = np.random.uniform(-1, 1, size=(batch_size,dim)).astype(np.float32)
    sess.run(d_trainer,feed_dict={x:x_value, z_noise:z_value,keep_prob:0.7})
    sess.run(g_trainer,feed_dict={x:x_value, z_noise:z_value,keep_prob:0.7})
    [c1,c2] = sess.run([discr_loss,gen_loss],feed_dict={x:x_value, z_noise:z_value,
    keep_prob:0.7})
    print ('iter:',i,'cost of discriminator',c1, 'cost of generator',c2)
#-----
# Generate a batch of synthetic fake images
#-----
out_val_img = sess.run(out_gen,feed_dict={z_noise:z_sample})
saver.save(sess, " newgan1",global_step=i)
#-----
# Plot the synthetic images generated
#-----
imgs = 0.5*(out_val_img + 1)

```

```

for k in range(36):
    plt.subplot(6,6,k+1)
    image = np.reshape(imgs[k],(28,28))
    plt.imshow(image,cmap='gray')

```

-- output --

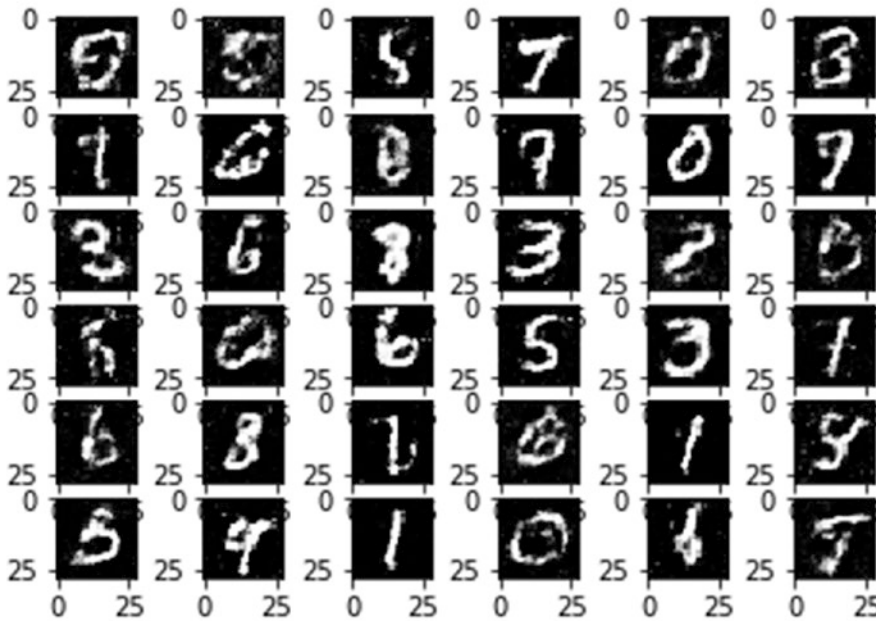

Figure 6-23. Digits synthetically generated by the GAN network

From Figure 6-23 we can see that the GAN generator is able to produce images similar to the MNIST dataset digits. The GAN model was trained on 60000 mini batches of size 256 to achieve this quality of results. The point I want to emphasize is that GANs are relatively hard to train in comparison to other neural networks. Hence, a lot of experimentation and customization is required in order to achieve the desired results.

TensorFlow Models' Deployment in Production

To export a trained TensorFlow model into production, TensorFlow Serving's capabilities can be leveraged. It has been created to ease machine learning model deployment into production. TensorFlow Serving, as the name suggests, hosts the model in production and provides applications with local access to it. The following steps can be used as a guideline to load a TensorFlow model into production:

- The TensorFlow model needs to be trained by activating the TensorFlow graph under an active session.

- Once the model is trained, TensorFlow's `SavedModelBuilder` module can be used to export the model. This `SavedModelBuilder` saves a copy of the model at a secure location so that it can be loaded easily when required. While invoking the `SavedModelBuilder` module, the export path needs to be specified. If the export path doesn't exist, TensorFlow's `SavedModelBuilder` will create the required directory. The model's version number can also be specified through the `FLAGS.model_version`.
- The TensorFlow meta-graph definition and other variables can be bonded with the exported model by using the `SavedModelBuilder.add_meta_graph_and_variable()` method. The option `signature_def_map` within this method acts as a map for the different user-supplied signatures. Signatures let one specify input and outputs tensors that would be required in order to send input data to the model for prediction and receive predictions or outputs from the model. For example, one can build the classification signature and the prediction signature for a model and tie those to the `signature_def_map`. The classification signature for a multi-class classification model on images can be defined to take an image tensor as input and produce a probability as output. Similarly, the prediction signature can be defined to take an image tensor as input and output the raw class scores. Sample code is provided by TensorFlow at https://github.com/tensorflow/serving/blob/master/tensorflow_serving/example/mnist_saved_model.py that can be used as an easy reference while exporting TensorFlow models.
- The model, once exported, can be loaded using Standard TensorFlow Model Server, or one can choose to use a locally compiled model server. More elaborate details on this can be found at the link provided at the TensorFlow site: https://www.tensorflow.org/serving/serving_basic.

Illustrated in Listing 6-6a is a basic implementation of saving a TensorFlow model and then reusing it for prediction purposes at test time. It has lot of commonalities with how a TensorFlow model is deployed in production.

Listing 6-6a. Illustration of How to Save a Model in TensorFlow

```
import tensorflow as tf
from tensorflow.examples.tutorials.mnist import input_data

batch_size, learning_rate = 256, 0.001
epochs = 10
total_iter = 1000

x = tf.placeholder(tf.float32, [None, 784], name='x')
y = tf.placeholder(tf.float32, [None, 10], name='y')

W = tf.Variable(tf.random_normal([784, 10], mean=0, stddev=0.02), name='W')
b = tf.Variable(tf.random_normal([10], mean=0, stddev=0.02), name='b')
logits = tf.add(tf.matmul(x, W), b, name='logits')
pred = tf.nn.softmax(logits, name='pred')
correct_prediction = tf.equal(tf.argmax(y, 1), tf.argmax(pred, 1), name='correct_prediction')
accuracy = tf.reduce_mean(tf.cast(correct_prediction, tf.float32), name='accuracy')
```

```

mnist = input_data.read_data_sets('MNIST_data', one_hot=True)
batches = (mnist.train.num_examples//batch_size)
saver = tf.train.Saver()

cost = tf.reduce_mean(tf.nn.sigmoid_cross_entropy_with_logits(logits=logits,labels=y))
optimizer_ = tf.train.AdamOptimizer(learning_rate).minimize(cost)
init = tf.global_variables_initializer()
with tf.Session() as sess:
    sess.run(init)
    for step in range(total_iter):
        batch_x,batch_y = mnist.train.next_batch(batch_size)
        sess.run(optimizer_, feed_dict={x:batch_x,y:batch_y})
        c = sess.run(cost,feed_dict={x:batch_x,y:batch_y})
        print ('Loss in iteration ' + str(step) + '= ' + str(c))
        if step % 100 == 0 :
            saver.save(sess,'/home/santanu/model_basic',global_step=step)
            saver.save(sess,'/home/santanu/model_basic',global_step=step)
            val_x,val_y = mnist.test.next_batch(batch_size)
            print('Accuracy:',sess.run(accuracy,feed_dict={x:val_x,y:val_y}))

--output --

```

```

Loss in iteration 991= 0.0870551
Loss in iteration 992= 0.0821354
Loss in iteration 993= 0.0925385
Loss in iteration 994= 0.0902953
Loss in iteration 995= 0.0883076
Loss in iteration 996= 0.0936614
Loss in iteration 997= 0.077705
Loss in iteration 998= 0.0851475
Loss in iteration 999= 0.0802716
('Accuracy:', 0.91796875)

```

The important thing in the preceding code is the creation of an instance of the `saver = tf.train.Save()` class. Calling the `save` method on the instantiated `saver` object within a TensorFlow session saves the whole session metagraph along with the values for the variables in the location specified. This is important, since the TensorFlow variables are only alive within a TensorFlow session, and thus this method can be used to retrieve a model created under a session later for prediction purposes, fine-tuning of the model, and so on.

The model is saved in the given location with the name specified; i.e., `model_basic`, and it has three components, as follows:

- `model_basic-9999.meta`
- `model_basic-9999.index`
- `model_basic-9999.data-00000-of-00001`

The component 9999 is the step number that got appended since we have added the `global_step` option, which appends the step number into the saved model files. This helps with versioning since we might be interested in multiple copies of the model at different steps. However, only the four latest versions are maintained by TensorFlow.

The `model_basic-9999.meta` file will contain the saved session graph, whereas the `model_basic-9999.data-00000-of-00001` and `model_basic-9999.index` files constitute the checkpoint file containing all the values for the different variables. Also, there would be a common checkpoint file containing information about all the available checkpoint files.

Now, let's see how we can restore the saved model. We can create the network by defining all the variables and ops manually, just like the original network. However, those definitions are already there in the `model_basic-9999.meta` file, and hence can be imported to the current session by using the `import_meta_graph` method as shown in Listing 6-6b. Once the metagraph is loaded, all that needs to be loaded are the values of different parameters. This is done through the `restore` method on the saver instance. Once this is done, the different variables can be referenced directly by their names. For instance, the `pred` and `accuracy` tensors are directly referenced by their names and are used further for prediction on new data. Similarly, the placeholders also need to be restored by their name for feeding in data to the different ops requiring it.

Illustrated in Listing 6-6b is the code implementation to restore the TensorFlow model and use it to do predictions and accuracy checks on the saved trained model.

Listing 6-6b. Illustration of Restoring a Saved Model in TensorFlow

```
batch_size = 256
with tf.Session() as sess:
    init = tf.global_variables_initializer()
    sess.run(init)
    new_saver = tf.train.import_meta_graph('/home/santanu/model_basic-999.meta')
    new_saver.restore(sess,tf.train.latest_checkpoint('./'))
    graph = tf.get_default_graph()
    pred = graph.get_tensor_by_name("pred:0")
    accuracy = graph.get_tensor_by_name("accuracy:0")
    x = graph.get_tensor_by_name("x:0")
    y = graph.get_tensor_by_name("y:0")
    val_x,val_y = mnist.test.next_batch(batch_size)
    pred_out = sess.run(pred,feed_dict={x:val_x})
    accuracy_out = sess.run(accuracy,feed_dict={x:val_x,y:val_y})
    print 'Accuracy on Test dataset:',accuracy_out
```

--output--

Accuracy on Test dataset: 0.871094

Summary

With this, we come to the end of both this chapter and this book. The concepts and models illustrated in this chapter, although more advanced, use techniques learned in earlier chapters. After reading this chapter, one should feel confident in implementing the variety of models discussed in the book as well as try implementing other different models and techniques in this ever-evolving deep-learning community. One of the best ways to learn and come up with new innovations in this field is to closely follow the other deep-learning experts and their work. And who better to follow than the likes of Geoffrey Hinton, [Yann LeCun](#), Yoshua Bengio, and Ian Goodfellow, among others. Also, I feel one should be closer to the math and science of deep learning rather than just use it as a black box to reap proper benefits out of it. With this, I end my notes. Thank you.

Index

■ A

- Activation functions, neuron/perceptron
 - binary threshold activation function, 102–103
 - linear activation function, 102
 - rectified linear unit, 106
 - sigmoid activation function, 103–104
 - SoftMax activation function, 104–105
 - tanh activation function, 107
- AdadeltaOptimizer, 133–134
- AdagradOptimizer, 130–131
- AdamOptimizer, 135
- Auto encoders
 - architecture, 323
 - cases, 324
 - combined classification network, class prediction, 326
 - denoising auto-encoder implementation, 333
 - element wise activation function, 324
 - hidden layer, 323
 - KL divergence, 327–329
 - learning rule of model, 324
 - multiple hidden layers, 325
 - network, class prediction, 326
 - sparse, 328
 - unsupervised ANN, 322

■ B

- Backpropagation, 109
 - convolution layer, 183–185
 - for gradient computation
 - cost derivative, 116
 - cost function, 109–110, 112
 - cross-entropy cost, SoftMax activation layer, 115
 - forward pass and backward pass, 114
 - hidden layer unit, 110
 - independent sigmoid output units, 111
 - multi-layer neural network, 113
 - neural networks, 114

- partial derivative, 115–116
- partial derivative, cost function, 112–113
- propagating error, 109
- sigmoid activation functions, 114
- SoftMax function, 114
- Softmax output layer, 114
- pooling layer, 186–187
- Backpropagation through time (BPTT), 256
- Batch normalization, 204–206
- Bayesian inference
 - Bernoulli distribution, 282
 - likelihood function, 281–284, 286
 - likelihood function plot, 284
 - posterior distribution, 281
 - posterior probability distribution, 281, 283, 285–286
 - prior, 283
 - prior probability distribution, 283, 285
- Bayesian networks, 38
- Bayes rule, 38
- Bernoulli distribution, 48–49
- Bidirectional RNN, 276–278
- Binary threshold activation function, 102–103
- Binomial distribution, 49
- Block Gibbs sampling, 305
- Boltzmann distribution, 279–280

■ C

- Calculus, 23
 - convex function, 30–31
 - convex set, 29–30
 - differentiation, 23–24
 - gradient of function, 24–25
 - Hessian matrix of function, 25
 - local and global minima, 28–29
 - maxima and minima of functions, 26
 - for univariate function, 26–28
 - multivariate convex and non-convex functions, 31–33

Calculus (*cont.*)
 non-convex function, 31
 positive semi-definite and definite, 29
 successive partial derivatives, 25
 Taylor series, 34

Central Limit theorem, 53

Collaborative filtering
 contrastive divergence, 315
 derived probabilities, 317
 description, 313
 energy configuration, 317
 joint configuration, 316
 matrix factorization method, 313
 probability of hidden unit, 316
 RBMs, 314
 restricted Boltzmann View, user, 314–315

Continuous bag of words (CBOW)
 hidden-layer embedding, 230
 hidden layer vector, 229, 231
 SoftMax output probability, 231
 TensorFlow implementation, 234
 word embeddings, 228–229

Contrastive divergence, 308–309, 315

Convolutional neural networks (CNNs), 153
 architectures, 206
 AlexNet, 208–209
 LeNet, 206–207
 ResNet, 210–211
 VGG16, 209–210
 components, 179
 convolution layer, 180–181
 input layer, 180
 pooling layer, 182
 convolution operation, 153
 2D convolution of image, 165–169
 2D convolution of signal, 163–165
 LTI/LSI systems, 153–155
 signals in one dimension, 155–156, 162–163
 digit recognition on MNIST
 dataset, 192–196
 dropout layers and regularization, 190–191
 elements, 153
 image-processing filters, 169
 Gaussian filter, 173
 gradient-based filters, 174–175
 identity transform, 177–178
 Mean filter, 169–171
 Median filter, 171–172
 Sobel edge-detection filter, 175–177
 for solving real-world problems, 196–203
 translational equivariance, 188–189
 pooling, 189–190
 weight sharing, 187

Cross-correlation, 180

■ D

Deep belief networks (DBNs)
 backpropagation, 318
 implementation, 319
 learning algorithm, 318
 MNIST dataset, 318
 RBMs, 317
 ReLU activation functions, 319
 schematic diagram, 317, 318
 sigmoid units, 318

Deep learning
 evolution
 artificial neural networks, 89–92
 artificial neuron structure, 90
 biological neuron structure, 89
 perceptron learning algorithms
 activation functions, hidden
 layers linear, 100–101
 backpropagation (*see* Backpropagation, for
 gradient computation)
 geometrical interpretation, 96–97
 hyperplane, classes, 93
 limitations, 97–98
 machine-learning domain, 94
 non-linearity, 99–100
 rule, multi-layer perceptrons
 network, 108–109
 weight parameters vector, 95
vs. traditional methods, 116–117

Denoising auto-encoder, 333

■ E

Elliptical contours, 123, 125

■ F

Forget-gate value, 264

Fully convolutional network (FCN)
 architecture, 356
 down and up sampling
 max unpooling, 360
 transpose convolution, 361, 363
 unpooling, 359
 output feature maps, network, 357–358
 pixel categories, 356
 SoftMax probability, 357

■ G, H

Gated recurrent unit (GRU), 274–276
 Gaussian blur, 173
 Generative adversarial networks (GANs)

- agents zero-sum game, 378
- cost function and training, 383–385
- generative models, 378
- illustration, 379
- maximin and minimax problem, 379–380
- minimax and saddle points, 382–383
- neural networks, 378
- TensorFlow implementation, 386
- vanishing gradient, generator, 386
- zero sum game, 381
- Gibbs sampling
 - bivariate normal distribution, 305
 - block, 305
 - burn in period, 306
 - conditional distributions, 305
 - generating samples, 306
 - Markov Chain Monte Carlo method, 304
 - restricted Boltzmann machines, 306–307
- Global co-occurrence methods, 241
 - building word vectors, 243–244
 - extraction, word embeddings, 242
 - statistics and prediction methods, 240
 - SVD method, 241
 - word combination, 241
 - Word-embeddings plot, 245
 - word-vector embedding matrix, 242
- Global minima, 28
- GloVe, 245
- Gradient clipping, 261
- Gradient descent, backpropagation, 236
- GradientDescentOptimizer, 130
- Graphical processing unit (GPU), 152

I, J

- Image classification, 373–374
- Image segmentation, 345
 - binary thresholding method,
 - histogram, 345, 349
 - FCN (*see* Fully convolutional network (FCN))
 - K-means clustering, 352
 - Otsu’s method, 346–349
 - semantic segmentation, 355
 - sliding window approach, 355
 - in TensorFlow implementation, semantic segmentation, 365
 - U-Net convolutional neural network, 364–365
 - Watershed algorithm, 349–352

K

- Karush Kahn Tucker method, 78
- K-means algorithm, 352
- Kullback-Leibler (KL) divergence
 - plot for mean, 327
 - sparse auto-encoders, 328–329

L

- Lagrangian multipliers, 79
 - Language modeling, 254–255
 - Lasso Regularization, 16
 - Linear activation function, 102
 - Linear algebra, 2
 - determinant of matrix, 12
 - interpretation, 13
 - Eigen vectors, 18–19
 - characteristic equation of matrix, 19–22
 - power iteration method, 22–23
 - identity matrix or operator, 11–12
 - inverse of matrix, 14
 - linear independence of vectors, 9–10
 - matrix, 4–5
 - matrix operations and manipulations, 5
 - addition of two matrices, 6
 - matrix working on vector, 8
 - product of two matrices, 6
 - product of two vectors, 7
 - subtractions of two matrices, 6
 - transpose of matrix, 7
 - norm of vector, 15–16
 - product of vector in direction of
 - another vector, 17–18
 - pseudo inverse of matrix, 16
 - rank of matrix, 10–11
 - scalar, 4
 - tensor, 5
 - unit vector in direction of specific vector, 17
 - vector, 3–4
- Linear shift invariant (LSI) systems, 153–155
 - Linear time invariant (LTI) systems, 153–155
 - Localization network, 373–374
 - Local minima point, 28
 - Long short-term memory (LSTM)
 - architecture, 262
 - building blocks and function, 262–263
 - exploding-and vanishing-gradient problems, 263–264
 - forget gate, 263
 - output gates, 263

M, N

- Machine learning, 55
 - constrained optimization problem, 77–79
 - and data science, 2
 - dimensionality reduction methods, 79
 - principal component analysis, 80–83
 - singular value decomposition, 83–84
 - optimization techniques
 - contour plot and lines, 68–70
 - gradient descent, 66
 - linear curve, 74

- Machine learning (*cont.*)
 - for multivariate cost function, gradient descent, 67–68
 - negative curvature, 75
 - Newton’s method, 74
 - positive curvature, 76–77
 - steepest descent, 70
 - stochastic gradient descent, 71–73
- regularization, 84–86
 - constraint optimization problem, 86–87
- supervised learning, 56
 - classification, 61–64
 - hyperplanes and linear classifiers, 64–65
 - linear regression, 56–61
 - unsupervised learning, 65
- Markov Chain, 288
- Markov Chain Monte Carlo (MCMC)
 - methods, 280
 - aperiodicity, 289
 - area of Pi, 287
 - computation of Pi, 287
 - detailed balance condition, 289
 - implementation, 289
 - irreducibility, 289
 - metropolis algorithm
 - acceptance probability, 291
 - bivariate Gaussian distribution, sampling, 291–293
 - heuristics, 290
 - implementation, 290
 - transition probability function, 290, 291
 - probability zones, 287
 - sampling, 286
 - states, gas molecules, 288
 - stochastic/random, 288
 - transition probability, 288
- Matrix factorization method, 313
- Maximum likelihood estimate (MLE)
 - technique, 52–53
- Max unpooling, 360
- Momentum-based optimizers, 136–137
- Monte Carlo method, 287
- Multi-layer Perceptron (MLP), 99

■ O

- Object detection
 - fast R-CNN network, 377
 - R-CNN network, 376–377
 - sliding-window technique, 375
 - task, 375
- Otsu’s method, 346–349
- Overfitting, 84

■ P, Q

- PCA and ZCA whitening
 - advantage, 340–341
 - illustration, 340–342
 - pixels, 340
 - spatial structure, 341
 - techniques, 340
 - whitening transform, 341
- Perceptron, 92
- Points of inflection, 26
- Principal component analysis, 279
 - See also* PCA and ZCA whitening
- Probability, 34
 - Bayes rule, 38
 - chain rule, 37
 - conditional independence of events, 38
 - correlation coefficient, 44
 - covariance, 44
 - distribution
 - Bernoulli distribution, 48–49
 - binomial distribution, 49
 - multivariate normal distribution, 48
 - normal distribution, 46–47
 - Poisson distribution, 50
 - uniform distribution, 45–46
 - expectation of random variable, 39
 - hypothesis testing and p value, 53–55
 - independence of events, 37
 - likelihood function, 51
 - MLE, 52–53
 - mutually exclusive events, 37
 - probability density function (pdf), 39
 - probability mass function (pmf), 38
 - skewness and Kurtosis, 40, 42
 - unions, intersection, and conditional, 35–37
 - variance of random variable, 39–40

■ R

- Rectified linear unit (ReLU) activation function, 106
- Recurrent neural networks (RNNs)
 - architectural principal, 252
 - bidirectional RNN, 276–278
 - BPTT, 256
 - component, 253–254
 - embeddings layer, 252
 - folded and unfolded structure, 252
 - GRU, 274–276
 - language modeling, 254–255
 - LSTM, 262–263
 - MNIST digit identification, TensorFlow
 - Alice in Wonderland, 273
 - implementation, LSTM, 266

- input tensor shape, LSTM network, 265
- next-word prediction and sentence completion, 268
- traditional language models, 255
- vanishing and exploding gradient problem
 - gradient clipping, 261
 - LSTMs, 263–264
 - memory-to-memory weight connection matrix and ReLU units, 261
 - sigmoid function, 259
 - temporal components, 259
- Restricted Boltzmann machines (RBMs)
 - Block Gibbs sampling, 305
 - collaborative filtering
 - binary visible unit, 315
 - contrastive divergence, 315
 - hidden units, 314–315, 317
 - joint configuration, 316
 - Netflix Challenge, 314
 - probability of hidden unit, 316
 - schematic diagram, matrix factorization method, 313
 - SoftMax function, 315
 - three-way energy configuration, 317
 - conditional probability distribution, 296
 - contrastive divergence, 308–309
 - DBNs (*see* Deep belief networks (DBNs))
 - deep networks, 294
 - discrete variables, 297
 - Gibbs sampling, 304–308
 - graphical probabilistic model, 295
 - implementation, MNIST dataset, 309
 - joint configuration, 295
 - joint probability distribution, 295, 298
 - machine learning algorithms, 294
 - partition function Z , 295
 - sigmoid function, 299
 - symmetrical undirected network, 299
 - training, 299
 - visible and hidden layers architecture, 294
- Ridge regression, 86
- Ridge regularization, 16
- RMSprop, 131–132

S

- Saddle points, 127, 129, 382–383
- Semantic segmentation, 355
 - in TensorFlow, FCN network, 365
- Sigmoid activation function, 103–104
- Singular value decomposition (SVD), 240–241, 313, 340
- Skip-gram models, 236
 - TensorFlow implementation, 240
 - word embedding, 235–237

- Sliding window approach, 355
- SoftMax activation function, 104–105
- Sparse auto-encoders
 - hidden layer output, 329
 - hidden layer sigmoid activations, 328
 - hidden structures, input data, 328
 - implementation, TensorFlow, 329
- Stochastic gradient descent (SGD), 71, 127
- Supremum norm, 15

T

- Tanh activation function, 107
- Taylor series expansion, 34
- TensorFlow
 - commands, define
 - check Tensor shape, 120
 - explicit evaluation, 120
 - Interactive Session() command, 119–121
 - invoke session and display, variable, 121
 - Numpy Array to Tensor conversion, 122
 - placeholders and feed dictionary, 122
 - TensorFlow and Numpy Library, 119
 - TensorFlow constants, 120
 - TensorFlow variable, random initial values, 121
 - tf.Session(), 121
 - variables, 121
 - variable state update, 122
 - deep-learning packages, 118
 - features, deep-learning frameworks, 118–119
 - gradient-descent optimization methods
 - elliptical contours, 123, 125
 - non-convexity of cost functions, 126
 - saddle points, 127, 129
 - installation, 119
 - linear regression
 - actual house price *vs.* predicted house price, 146
 - cost plot over epochs, 145
 - implementation, 143
 - meta graph definition, 390
 - mini-batch stochastic gradient descent, rate, 129
 - models deployment, production, 389–392
 - multi-class classification, SoftMax function
 - full-batch gradient descent, 146
 - stochastic gradient descent, 149
 - optimizers
 - AdadeltaOptimizer, 133–134
 - AdagradOptimizer, 130–131
 - AdamOptimizer, 135
 - batch size, 138
 - epochs, 138
 - GradientDescentOptimizer, 130

■ INDEX

TensorFlow (*cont.*)

MomentumOptimizer and Neterov

Algorithm, [136-137](#)

number of batches, [138](#)

RMSprop, [131-132](#)

XOR implementation

computation graph, [140-141](#)

hidden layers, [138](#)

linear activation functions,

hidden layer, [142](#)

Traditional language models, [255](#)

Transfer learning, [211](#)

with Google InceptionV3,

[213-214](#), [216](#)

guidelines, [212](#)

with pre-trained VGG16,

[216-219](#), [221](#)

Transpose convolution, [361](#), [363](#)

■ U

U-Net architecture, [364](#)

Unpooling, [359](#)

■ V

Vector representation of words, [227](#)

Vector space model (VSM), [227](#)

■ W, X, Y

Watershed algorithm, [349-352](#)

Word-embeddings plot, [245](#)

Word-embedding vector, [228-230](#)

Word2Vec

CBOW method (*see* Continuous bag of words (CBOW))

global co-occurrence methods, [240](#)

GloVe, [245](#)

skip-gram models, [235-237](#)

TensorFlow implementation, CBOW, [231](#)

word analogy, word vectors, [249](#)

Word-vector embeddings matrix, [242](#)

■ Z

Zero sum game, [381](#)