

FACE RECOGNITION USING PRINCIPAL COMPONENT ANALYSIS (PCA)

a project report submitted to
Galgotias University, Greater Noida

SUBMITTED BY

Abhishek Madhwal- 16SCSE105110

(B.Tech Cloud -1)

**BACHELOR OF TECHNOLOGY
IN
COMPUTER SCIENCE AND ENGINEERING**

Under the guidance of

Dr .M. Thirunavukkarasan

Assistant Professor of C.S.E dept



DEPARTMENT OF COMPUTER SCIENCE AND ENGINEERING
GALGOTIAS UNIVERSITY

(UNDER THE UTTAR PRADESH PRIVATE UNIVERSITIES ACT NO 12 OF 2019)

ACKNOWLEDGEMENT

I thank the almighty for giving us the courage and perseverance in completing the main project. This project itself is acknowledgements for all those people who have give us their heartfelt co-operation in making this project a grand success. I specially thanks to our Project coordinator/evaluator, **Ms. Varsha Sisuadia**, Associate Professor ,(Computer Science and Enigeering), for his support and valuable suggestions regarding project work. I am greatly in debted to project guide **Dr.M.Thirunavukkarasan**,Assistant Professor, (Computer Science and Engineering), for providing valuable guidance at every stage of this project work. I am profoundly grateful towards the unmatched services rendered by him. Our special thanks to all the faculty of Computer Science and Engineering and peers for their valuable advises at every stage of this work

FACE DETECTION SYSTEM USING **PRINCIPAL COMPONENT ANALYSIS**

ABSTRACT

The face is one of the easiest ways to distinguish the individual identity of each other. Face recognition is a personal identification system that uses personal characteristics of a person to identify the person's identity. Human face recognition procedure basically consists of two phases, namely face detection, where this process takes place very rapidly in humans, except under conditions where the object is located at a short distance away, the next is the introduction, which recognize a face as individuals. Stage is then replicated and developed as a model for facial image recognition (face recognition) is one of the much-studied biometrics technology and developed by experts. There are two kinds of methods that are currently popular in developed face recognition pattern namely, Eigenface method and Fisherface method. Facial image recognition Eigenface method is based on the reduction of face-dimensional space using Principal Component Analysis (PCA) for facial features. The main purpose of the use of PCA on face recognition using Eigen faces was formed (face space) by finding the eigenvector corresponding to the largest eigenvalue of the face image. The area of this project face detection system with face recognition is Image processing. The software requirements for this project is matlab software.

Keywords: face detection, Eigen face, PCA, matlab

Extension: There are vast number of applications from this face detection project, this project can be extended that the various parts in the face can be detect which are in various directions and shapes.

INDEX

CONTENTS	page
LIST OF FIGURES	
ABSTRACT	
1.INRODUCTION	1
1.1. FACE RECOGNIZATION	1
1.1.1 GEOMWTRIC	1
1.1.2 PHOTOMETRIC	1
1.2 FACE DETECTION	2
1.2.1 PRE-PROCSSING	2
1.2.2 CLASSIFICATION	3
1.2.3 LOCALIZATION	3
2. LITERATURE SURVEY.....	4
2.1.FEATURE BASE APPROCH.....	4
2.1.1 DEFORMABLE TEMPLATES	5
2.1.2 POINT DISTRIBUTION MODEL(PDM)	6
2.2. LOW LEVEL ANALYSIS	6
2.3.MOTION BASE	8
2.3.1 GRAY SCALE BASE... ..	8
2.3.2 EDGE BASE.....	9
2.4 FEATURE ANALYSIS	9
2.4.1 FEATURE SEARCHING.....	9
2.5 CONSTELLATION METHOD	10
2.5.1 NEURAL NETWORK	10
2.6 LINEAR SUB SPACE METHOD	11
2.7 STASTICAL APPROCH... ..	12
3. PRICIPAL COMPONENT ANALYSIS	13
3.1. PRINCIPAL COMPONENT ANALYSIS	13
3.2. EIGEN FACE	14
3.3. EIGEN VALUE AND VECTOR... ..	15

4. MATLAB.....	17
4.1. INTROUDUCTION... ..	17
4.2. MATLAB's POWER OF COMPUTAIONAL MATHMATICS.....	17
4.3. FEATURES OF MATLAB	18
4.4. USES OF MATLAB.....	18
4.5. UNDERSTANDING THE MATLAB ENVIRONMENT... ..	19
4.6. COMMONLY USED OPERATORS AND SPATIAL CHARECTERS.....	21
4.7. COMMANDS.....	22
4.7.1. COMMANDS FOR MANAGING A SESSION.....	22
4.8 INPUT AND OUTPUT COMMAND.....	23
4.9. M FILES	23
4.10. DATA TYPES AVAILABLE IN MATLAB	24
5. FACE DETECTION.....	26
5.1 FACE DETECTION IN IMAGE.....	26
5.2 REAL TIME FACE DETECTION	27
5.3 FACE DETECTION PROCESS.....	29
5.4 FACE DETETION ALGORITHM.....	32
6. FACE RECOGNITION	34
6.1 FACE RECOGNITION USING GEOMETRICAL FEATURES	34
6.1.1 FACE RECOGNITION USING TEMPLATE MATCHING	35
6.2. PROBLEM SCOPE AND SYSTEM SPECIFICATIONS	36
6.3 BRIEF OUTLINE OF THE IMPLEMENTED SYSTEM.....	36
6.4 FACE RECOGNITION DIFFICULTIE.....	38
6.4.1 INTER CLASS SIMILARITY	39
6.4.2 INTRA CLASS SIMILARITY	39
6.5 PRINCIPAL COMPONENT ANALYSIS	40
6.6 UNDER STANDING EIGEN FACES	40
6.7 IMPROVING FACE DETECTION USING RECONSTRUCTION	44
6.8 POSE INVARIANT FACE RECOGNITION	45
7. CONCLUSION	47
8. REFERENCES.....	49

LIST OF FIGURES

1.2 FACE DETECTION ALGORITHM	3
2.1 DETECTION METHODS	4
2.2 FACE DETECTION	7
3.2 PCA ALGORITHM	14
3.3 EIGEN FACES	15
5.1 A SUCCESSFUL FACE DETECTION IN AN IMAGE WITH A FRONTAL VIEW OF A HUMAN FACE.....	26
5.2.1 FRAME 1 FROM CAMERA	28
5.2.2 FRAME 2 FROM CAMERA	28
5.2.3 SPATIO - TEMPORALLY FILTERED IMAGE.....	28
5.3 FACE DETECTION.....	29
5.3.1 AVERAGE HUMAN FACE IN GREY-SCALE	29
5.3.2 AREA CHOSEN FOR FACE DETECTION	30
5.3.3: BASIS FOR A BRIGHT INTENSITY INVARIANT SENSITIVE TEMPLATE	30
5.3.4 SCANED IMAGE DETECTION	31
5.4 FACE DETECTION ALGORITHM.....	32
5.4.1 MOUTH DETECTION	31
5.4.2 NOISE DETECTION	31
5.4.3 EYE DETECTION	33
6.1.1 FACE RECOGNITION USING TEMPLATE MATCHING.....	35
6.3 IMPLEMENTED FULLY AUTOMATED FRONTAL VIEW FACE DETECTION MODEL	36
6.3.1 : PRINCIPAL COMPONENT ANALYSIS TRANSFORM FROM 'IMAGE SPACE' TO 'FACE SPACE'	37
6.3.2 FACE RECOGNITION	38
6.4.1 FACE RECOGNITION TWINS AND FATHER AND SON.....	39
6.6.0 A 7X7 FACE IMAGE TRANSFORMED INTO A 49 DIMENSION VECTOR	40
6.6.1 EIGENFACES	41
6.8 POSE INVARIANT FACE RECOGNITION	46

CHAPTER-1 INTRODUCTION

Face recognition is the task of identifying an already detected object as a known or unknown face. Often the problem of face recognition is confused with the problem of face detection. Face Recognition on the other hand is to decide if the "face" is someone known, or unknown, using for this purpose a database of faces in order to validate this input face.

1.1 FACE RECOGNITION:

DIFFERENT APPROACHES OF FACE RECOGNITION:

There are two predominant approaches to the face recognition problem: Geometric (feature based) and photometric (view based). As researcher interest in face recognition continued, many different algorithms were developed, three of which have been well studied in face recognition literature.

Recognition algorithms can be divided into two main approaches:

1. **Geometric:** Is based on geometrical relationship between facial landmarks, or in other words the spatial configuration of facial features. That means that the main geometrical features of the face such as the eyes, nose and mouth are first located and then faces are classified on the basis of various geometrical distances and angles between features. (Figure 3)
2. **Photometric stereo:** Used to recover the shape of an object from a number of images taken under different lighting conditions. The shape of the recovered object is defined by a gradient map, which is made up of an array of surface normals (Figure 2)

Popular recognition algorithms include:

1. Principal Component Analysis using Eigenfaces, (PCA)
2. Linear Discriminate Analysis,
3. Elastic Bunch Graph Matching using the Fisherface algorithm,

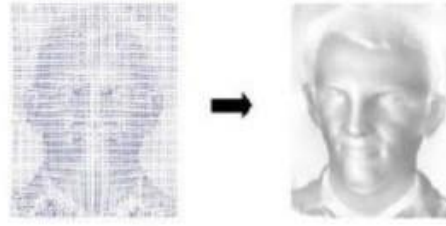

Figure 2 -Photometric stereo image.

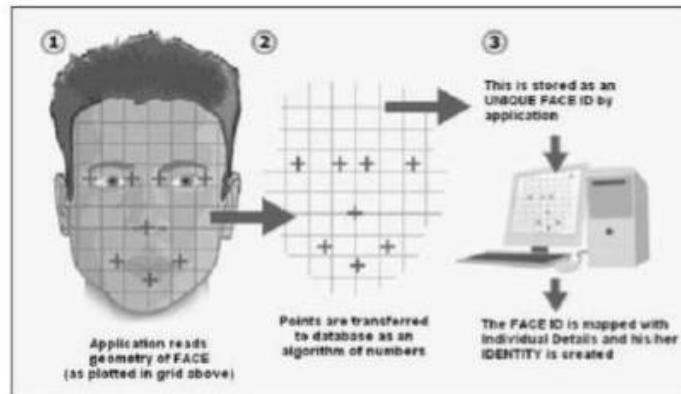

Figure 3 - Geometric facial recognition.

1.2 FACE DETECTION:

Face detection involves separating image windows into two classes; one containing faces (tarning the background (clutter)). It is difficult because although commonalities exist between faces, they can vary considerably in terms of age, skin colour and facial expression. The problem is further complicated by differing lighting conditions, image qualities and geometries, as well as the possibility of partial occlusion and disguise. An ideal face detector would therefore be able to detect the presence of any face under any set of lighting conditions, upon any background. The face detection task can be broken down into two steps. The first step is a classification task that takes some arbitrary image as input and outputs a binary value of yes or no, indicating whether there are any faces present in the image. The second step is the face localization task that aims to take an image as input and output the location of any face or faces within that image as some bounding box with (x, y, width, height).

The face detection system can be divided into the following steps:-

1. Pre-Processing: To reduce the variability in the faces, the images are processed before they are fed into the network. All positive examples that is the face images are obtained by cropping

images with frontal faces to include only the front view. All the cropped images are then corrected for lighting through standard algorithms.

2. Classification: Neural networks are implemented to classify the images as faces or nonfaces by training on these examples. We use both our implementation of the neural network and the Matlab neural network toolbox for this task. Different network configurations are experimented with to optimize the results.

3. Localization: The trained neural network is then used to search for faces in an image and if present localize them in a bounding box. Various Feature of Face on which the work has done on:- Position Scale Orientation Illumination

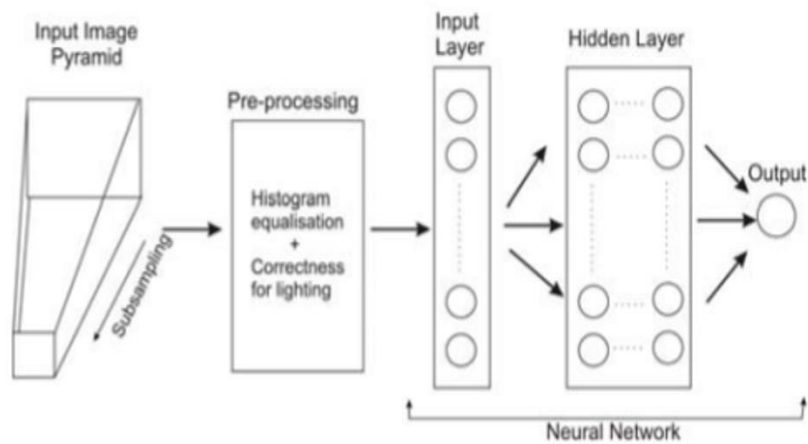

Fig: Face detection algorithm

CHAPTER-2

LITERATURE SURVEY

Face detection is a computer technology that determines the location and size of human face in arbitrary (digital) image. The facial features are detected and any other objects like trees, buildings and bodies etc are ignored from the digital image. It can be regarded as a ‘specific’ case of object-class detection, where the task is finding the location and sizes of all objects in an image that belong to a given class. Face detection, can be regarded as a more ‘general’ case of face localization. In face localization, the task is to find the locations and sizes of a known number of faces (usually one). Basically there are two types of approaches to detect facial part in the given image i.e. feature base and image base approach. Feature base approach tries to extract features of the image and match it against the knowledge of the face features. While image base approach tries to get best match between training and testing images.

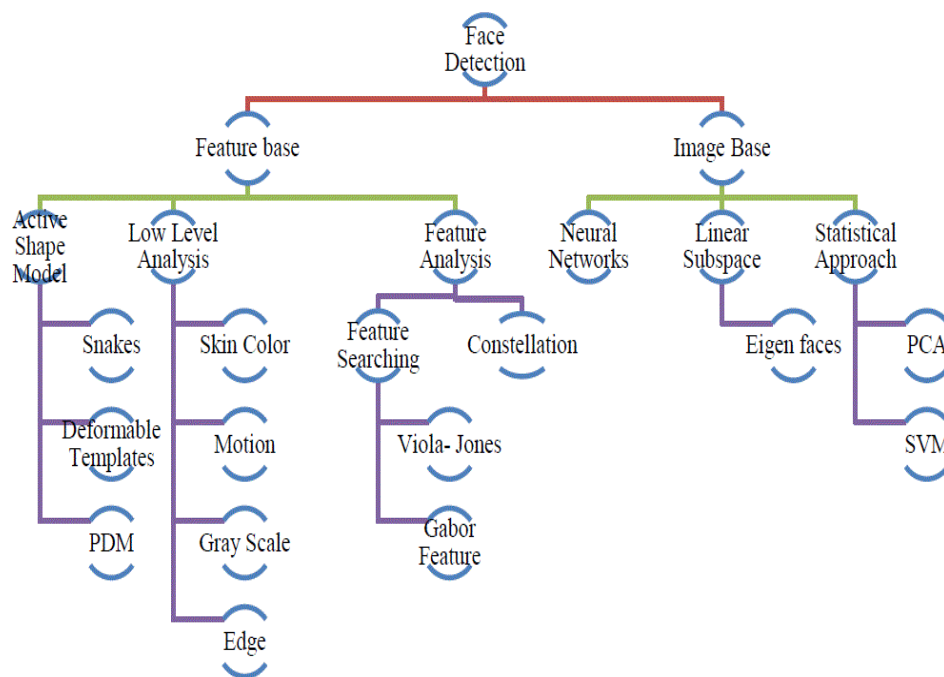

Fig 2.1 detection methods

2.1 FEATURE BASE APPROACH:

Active Shape Model Active shape models focus on complex non-rigid features like actual physical and higher level appearance of features Means that Active Shape Models (ASMs) are aimed at automatically locating landmark points that define the shape of any statistically modelled

object in an image. When of facial features such as the eyes, lips, nose, mouth and eyebrows. The training stage of an ASM involves the building of a statistical

- a) facial model from a training set containing images with manually annotated landmarks. ASMs is classified into three groups i.e. snakes, PDM, Deformable templates
- b) 1.1)Snakes:The first type uses a generic active contour called snakes, first introduced by Kass et al. in 1987 Snakes are used to identify head boundaries [8,9,10,11,12]. In order to achieve the task, a snake is first initialized at the proximity around a head boundary. It then locks onto nearby edges and subsequently assume the shape of the head. The evolution of a snake is achieved by minimizing an energy function, E_{snake} (analogy with physical systems), denoted as $E_{snake} = E_{internal} + E_{external}$ Where $E_{internal}$ and $E_{external}$ are internal and external energy functions. Internal energy is the part that depends on the intrinsic properties of the snake and defines its natural evolution. The typical natural evolution in snakes is shrinking or expanding. The external energy counteracts the internal energy and enables the contours to deviate from the natural evolution and eventually assume the shape of nearby features—the head boundary at a state of equilibria. Two main consideration for forming snakes i.e. selection of energy terms and energy minimization. Elastic energy is used commonly as internal energy. Internal energy is vary with the distance between control points on the snake, through which we get contour an elastic-band characteristic that causes it to shrink or expand. On other side external energy relay on image features. Energy minimization process is done by optimization techniques such as the steepest gradient descent. Which needs highest computations. Huang and Chen and Lam and Yan both employ fast iteration methods by greedy algorithms. Snakes have some demerits like contour often becomes trapped onto false image features and another one is that snakes are not suitable in extracting non convex features.

2.1.1 Deformable Templates:

Deformable templates were then introduced by Yuille et al. to take into account the a priori of facial features and to better the performance of snakes. Locating a facial feature boundary is not an easy task because the local evidence of facial edges is difficult to organize into a sensible global entity using generic contours. The low brightness contrast around some of these features also makes the edge detection process. Yuille et al. took the concept of snakes a step further by incorporating global information of the eye to improve the reliability of the extraction process.

Deformable templates approaches are developed to solve this problem. Deformation is based on local valley, edge, peak, and brightness. Other than face boundary, salient feature (eyes, nose, mouth and eyebrows) extraction is a great challenge of face recognition. $E = E_v + E_e + E_p + E_i + E_{\text{internal}}$; where E_v , E_e , E_p , E_i , E_{internal} are external energy due to valley, edges, peak and image brightness and internal energy

2.1.2 PDM (Point Distribution Model):

Independently of computerized image analysis, and before ASMs were developed, researchers developed statistical models of shape. The idea is that once you represent shapes as vectors, you can apply standard statistical methods to them just like any other multivariate object. These models learn allowable constellations of shape points from training examples and use principal components to build what is called a Point Distribution Model. These have been used in diverse ways, for example for categorizing Iron Age broaches. Ideal Point Distribution Models can only deform in ways that are characteristic of the object. Cootes and his colleagues were seeking models which do exactly that so if a beard, say, covers the chin, the shape model can "override the image" to approximate the position of the chin under the beard. It was therefore natural (but perhaps only in retrospect) to adopt Point Distribution Models. This synthesis of ideas from image processing and statistical shape modelling led to the Active Shape Model. The first parametric statistical shape model for image analysis based on principal components of inter-landmark distances was presented by Cootes and Taylor in. On this approach, Cootes, Taylor, and their colleagues, then released a series of papers that cumulated in what we call the classical Active Shape Model.

2.2) LOW LEVEL ANALYSIS:

Based on low level visual features like color, intensity, edges, motion etc. Skin Color Base Color is a vital feature of human faces. Using skin-color as a feature for tracking a face has several advantages. Color processing is much faster than processing other facial features. Under certain lighting conditions, color is orientation invariant. This property makes motion estimation much easier because only a translation model is needed for motion estimation. Tracking human faces using color as a feature has several problems like the color representation of a face obtained by a camera is influenced by many factors (ambient light, object movement, etc

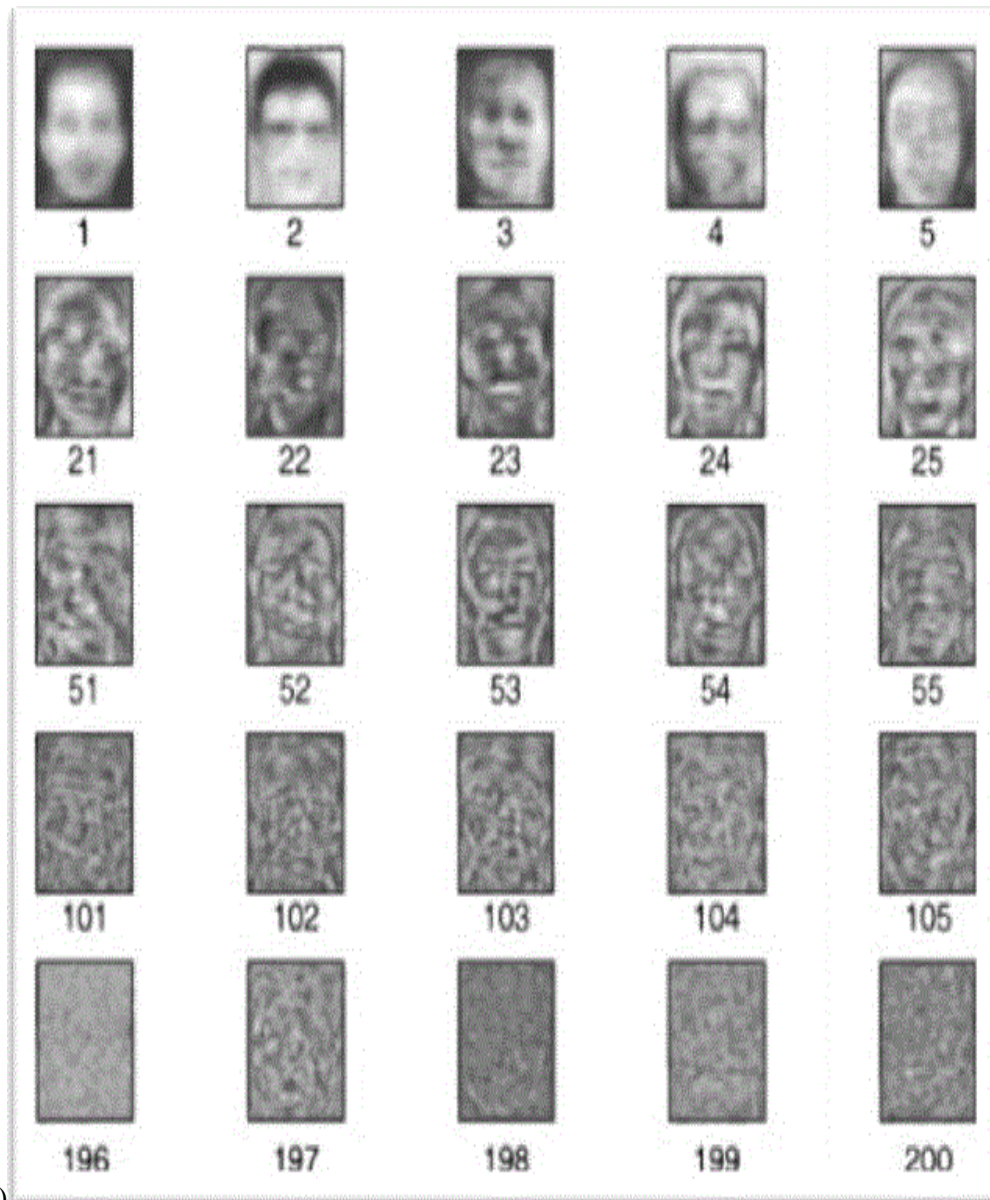

Fig 2.2. face detection

Majorly three different face detection algorithms are available based on RGB, YCbCr, and HIS color space models. In the implementation of the algorithms there are three main steps viz.

- (1) Classify the skin region in the color space,
- (2) Apply threshold to mask the skin region and
- (3) Draw bounding box to extract the face image.

Crowley and Coutaz suggested simplest skin color algorithms for detecting skin pixels. The perceived human color varies as a function of the relative direction to the illumination.

The pixels for skin region can be detected using a normalized color histogram, and can be normalized for changes in intensity on dividing by luminance. Converted an $[R, G, B]$ vector is converted into an $[r, g]$ vector of normalized color which provides a fast means of skin detection. This algorithm fails when there are some more skin region like legs, arms, etc. Cahil and Ngan [27] suggested skin color classification algorithm with YCbCr color space. Research found that pixels belonging to skin region having similar Cb and Cr values. So that the thresholds be chosen as $[Cr_1, Cr_2]$ and $[Cb_1, Cb_2]$, a pixel is classified to have skin tone if the values $[Cr, Cb]$ fall within the thresholds. The skin color distribution gives the face portion in the color image. This algorithm is also having the constraint that the image should be having only face as the skin region. Kjeldson and Kender defined a color predicate in HSV color space to separate skin regions from background. Skin color classification in HSI color space is the same as YCbCr color space but here the responsible values are hue (H) and saturation (S). Similar to above the threshold be chosen as $[H_1, S_1]$ and $[H_2, S_2]$, and a pixel is classified to have skin tone if the values $[H, S]$ fall within the threshold and this distribution gives the localized face image. Similar to above two algorithm this algorithm is also having the same constraint.

2.3) MOTION BASE:

When use of video sequence is available, motion information can be used to locate moving objects. Moving silhouettes like face and body parts can be extracted by simply thresholding accumulated frame differences. Besides face regions, facial features can be located by frame differences.

2.3.1 Gray Scale Base:

Gray information within a face can also be treated as important features. Facial features such as eyebrows, pupils, and lips appear generally darker than their surrounding facial regions. Various recent feature extraction algorithms search for local gray minima within segmented facial regions. In these algorithms, the input images are first enhanced by contrast-stretching and gray-scale morphological routines to improve the quality of local dark patches and thereby make detection easier. The extraction of dark patches is achieved by low-level gray-scale thresholding. Based method and consist three levels. Yang and Huang presented new approach i.e. faces gray scale behaviour in pyramid (mosaic) images. This system utilizes hierarchical Face location consist three levels. Higher two level based on mosaic images at different resolution. In the lower level, edge detection method is proposed. Moreover this algorithm gives fine response in complex background where size of the face is unknown

2.3.2 Edge Base:

Face detection based on edges was introduced by Sakai et al. This work was based on analysing line drawings of the faces from photographs, aiming to locate facial features. Then later Craw et al. proposed a hierarchical framework based on Sakai et al.'s work to trace a human head outline. Then after remarkable works were carried out by many researchers in this specific area. Method suggested by Anila and Devarajan was very simple and fast. They proposed a framework which consists of three steps: i.e. initially the images are enhanced by applying median filter for noise removal and histogram equalization for contrast adjustment. In the second step the edge image is constructed from the enhanced image by applying Sobel operator. Then a novel edge tracking algorithm is applied to extract the sub-windows from the enhanced image based on edges. Further they used Back propagation Neural Network (BPN) algorithm to classify the sub-window as either face or non-face.

2.4 FEATURE ANALYSIS

These algorithms aim to find structural features that exist even when the pose, viewpoint, or lighting conditions vary, and then use these to locate faces. These methods are designed mainly for face localization.

2.4.1 Feature Searching

Viola Jones Method:

Paul Viola and Michael Jones presented an approach for object detection which minimizes computation time while achieving high detection accuracy. Paul Viola and Michael Jones proposed a fast and robust method for face detection which is 15 times quicker than any technique at the time of release with 95% accuracy at around 17 fps. The technique relies on the use of simple Haar-like features that are evaluated quickly through the use of a new image representation. Based on the concept of an —Integral Image¹ it generates a large set of features and uses the boosting algorithm AdaBoost to reduce the overcomplete set and the introduction of a degenerative tree of the boosted classifiers provides for robust and fast inferences. The detector is applied in a scanning fashion and used on gray-scale images, the scanned window that is applied can also be scaled, as well as the features evaluated.

Gabor Feature Method:

Sharif et al proposed an Elastic Bunch Graph Map (EBGM) algorithm that successfully implements face detection using Gabor filters. The proposed system applies 40 different Gabor filters on an image. As a result of which 40 images with different angles and orientation are received. Next, maximum intensity points in each filtered image are calculated and mark them as fiducial points. The system reduces these points in accordance to distance between them. The next step is calculating the distances between the reduced points

using distance formula. At last, the distances are compared with database. If match occurs, it means that the faces in the image are detected. Equation of Gabor filter is shown below`

$$\psi_{u,v}(z) = \frac{\|k_{u,v}\|^2}{\sigma^2} e^{\left(\frac{\|k_{u,v}\|^2 \|z\|^2}{2\sigma^2}\right)} \left[e^{i\vec{k}_{u,v}z} - e^{-\frac{\sigma^2}{2}} \right]$$

Where

$$\phi_u = \frac{u\pi}{8}, \quad \phi_u \in [0, \pi) \text{ gives the frequency,}$$

2.5 CONSTELLATION METHOD

All methods discussed so far are able to track faces but still some issue like locating faces of various poses in complex background is truly difficult. To reduce this difficulty investigator form a group of facial features in face-like constellations using more robust modelling approaches such as statistical analysis. Various types of face constellations have been proposed by Burl et al. . They establish use of statistical shape theory on the features detected from a multiscale Gaussian derivative filter. Huang et al. also apply a Gaussian filter for pre-processing in a framework based on image feature analysis. Image Base Approach.

2.5.1 Neural Network

Neural networks gaining much more attention in many pattern recognition problems, such as OCR, object recognition, and autonomous robot driving. Since face detection can be treated as

a two class pattern recognition problem, various neural network algorithms have been proposed.

The advantage of using neural networks for face

detection is the feasibility of training a system to capture the complex class conditional density of face patterns. However, one demerit is that the network architecture has to be extensively tuned (number of layers, number of nodes, learning rates, etc.) to get exceptional performance. In early days most hierarchical neural network was proposed by Agui et al. The first stage having two parallel subnetworks in which the inputs are filtered intensity values from an original image. The inputs to the second stage network consist of the outputs from the subnetworks and extracted feature values. An output at this second stage shows the presence of a face in the input region. Propp and Samal developed one of the earliest neural networks for face detection. Their network consists of four layers with 1,024 input units, 256 units in the first hidden layer, eight units in the second hidden layer, and two output units. Feraud and Bernier presented a detection method using auto associative neural networks. The idea is based on [which shows an auto associative network with five layers is able to perform a nonlinear principal component analysis. One auto associative network is used to detect frontal- view faces and another one is used to detect faces turned up to 60 degrees to the left and right of the frontal view. After that Lin et al. presented a face detection system using probabilistic decision-based neural network (PDBNN). The architecture of PDBNN is similar to a radial basis function (RBF) network with modified learning rules and probabilistic interpretation.

2.6 LINEAR SUB SPACE METHOD

Eigen faces Method:

An early example of employing eigen vectors in face recognition was done by Kohonen in which a simple neural network is demonstrated to perform face recognition for aligned and normalized face images. Kirby and Sirovich suggested that images of faces can be linearly encoded using a modest number of basis images. The idea is arguably proposed first by Pearson in 1901 and then by HOTELLING in 1933. Given a collection of n by m pixel training.

Images represented as a vector of size $m \times n$, basis vectors spanning an optimal subspace are determined such that the mean square error between the projection of the training images onto this subspace and the original images is minimized. They call the set of optimal basis vectors Eigen pictures since these are simply the eigen vectors of the covariance matrix computed from the vectorized face images in the training set. Experiments with a set of 100 images show that a face image of 91×50 pixels can be effectively encoded using only 50 Eigen pictures.

A reasonable likeness (i.e., capturing 95 percent of the variance)

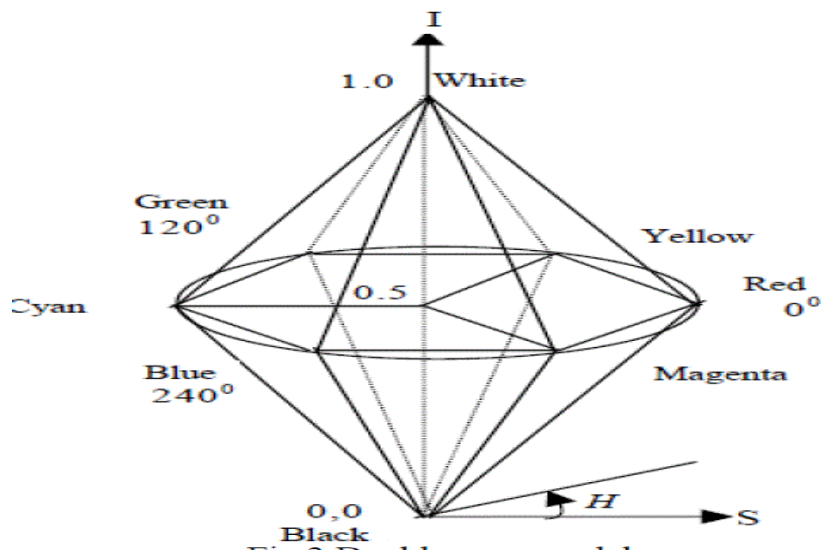

2.7 STATISTICAL APPROACH

Support Vector Machine (SVM):

SVMs were first introduced by Osuna et al. for face detection. SVMs work as a new paradigm to train polynomial function, neural networks, or radial basis function (RBF) classifiers. SVMs work on induction principle, called structural risk minimization, which targets to minimize an upper bound on the expected generalization error. An SVM classifier is a linear classifier where the separating hyper plane is chosen to minimize the expected classification error of the unseen test patterns. In Osuna et al. developed an efficient method to train an SVM for large scale problems, and applied it to face detection. Based on two test sets of 10,000,000 test patterns of 19 X 19 pixels, their system has slightly lower error rates and runs approximately 30 times faster than the system by Sung and Poggio. SVMs have also been used to detect faces and pedestrians in the wavelet domain.

CHAPTER-3

PRINCIPAL COMPONENT ANALYSIS

3.1 Principal Component Analysis (PCA)

Face recognition is a pattern recognition problem, so training/learning algorithm should be used to make comparison between the faces. For 2D recognition, Linear/Nonlinear Projection methods are used. The Linear/Nonlinear Projection methods are Principal component analysis, Linear Discriminant Analysis (LDA).

2D Linear/Nonlinear Projection methods generate feature vector for each person, then classify the input person inside the database. Generating feature vector also has importance to reduce dimension of the input images.

PCA is a useful statistical technique that has found application in fields such as face recognition and image compression, and is a common technique for finding patterns in data of high dimension.

It is a way of identifying patterns in data, and expressing the data in such a way as to highlight their similarities and differences. The other main advantage of PCA is that once you have found these patterns in the data, and you compress the data, i.e. by reducing the number of dimensions, without much loss of information.

Problems arise when we wish to perform recognition in a high-dimensional space. Goal of PCA is to reduce the dimensionality of the data by retaining as much as variation possible in our original data set. On the other hand dimensionality reduction implies information loss. The best low-dimensional space can be determined by best principal components.

Principal component analysis (PCA) was invented in 1901 by Karl Pearson. PCA is a variable reduction procedure and useful when obtained data have some redundancy. This will result into reduction of variables into smaller number of variables which are called Principal Components which will account for the most of the variance in the observed variable. Problems arise when we wish to perform recognition in a high-dimensional space. Goal of PCA is to reduce the dimensionality of the data by retaining as much as variation possible in our original data set. On the other hand

dimensionality reduction implies information loss. The best low-dimensional space can be determined by best principal components.

1. Compute the mean feature vector

$$\mu = \frac{1}{p} \sum_{k=1}^p x_k, \text{ where, } x_k \text{ is a pattern } (k = 1 \text{ to } p), p = \text{number of patterns, } x \text{ is the feature matrix}$$

2. Find the covariance matrix

$$C = \frac{1}{p} \sum_{k=1}^p \{x_k - \mu\} \{x_k - \mu\}^T \text{ where, } T \text{ represents matrix transposition}$$

3. Compute Eigen values λ_i and Eigen vectors v_i of covariance matrix

$$Cv_i = \lambda_i v_i \quad (i = 1, 2, 3, \dots, q), q = \text{number of features}$$

4. Estimating high-valued Eigen vectors

- (i) Arrange all the Eigen values (λ_i) in descending order
- (ii) Choose a threshold value, θ
- (iii) Number of high-valued λ_i can be chosen so as to satisfy the relationship

$$\left(\sum_{i=1}^s \lambda_i \right) \left(\sum_{i=1}^q \lambda_i \right)^{-1} \geq \theta, \text{ where, } s = \text{number of high valued } \lambda_i \text{ chosen}$$

- (iv) Select Eigen vectors corresponding to selected high valued λ_i

5. Extract low dimensional feature vectors (principal components) from raw feature matrix.

$$P = V^T x, \text{ where, } V \text{ is the matrix of principal components and } x \text{ is the feature matrix}$$

3.2 Eigenface

The Eigenface method is one of the generally used algorithm for face recognition. Karhunen-Loeve is based on the eigenfaces technique in which the Principal Component Analysis (PCA) is used. This method is successfully used to perform dimensionality reduction. Principal Component Analysis is used by face recognition and detection. Mathematically, Eigenfaces are the principal components divide the face into feature vectors. The feature vector information can be obtained from covariance matrix. These Eigenvectors are used to quantify the variation between multiple faces. The faces are characterized by the linear combination of highest Eigenvalues. Each face can be considered as a linear combination of the eigenfaces. The face can be approximated by using the eigenvectors having the largest eigenvalues. The best M eigenfaces define an M dimensional space, which is called as the “face space”. Principal

Component Analysis is also used by L. Sirovich and M. Kirby to efficiently represent pictures of faces. They defined that a face images could be approximately reconstructed using a small collection of weights for each face and a standard face picture. The weights describing each face are obtained by projecting the face image onto the eigenpicture . Eigenface is a practical approach for face recognition. Because of the simplicity of its algorithm, implementation of an eigenface recognition system becomes easy. It is efficient in processing time and storage. PCA reduces the dimension size of an image in a short period of time. There is a high correlation between the training data and the recognition data.

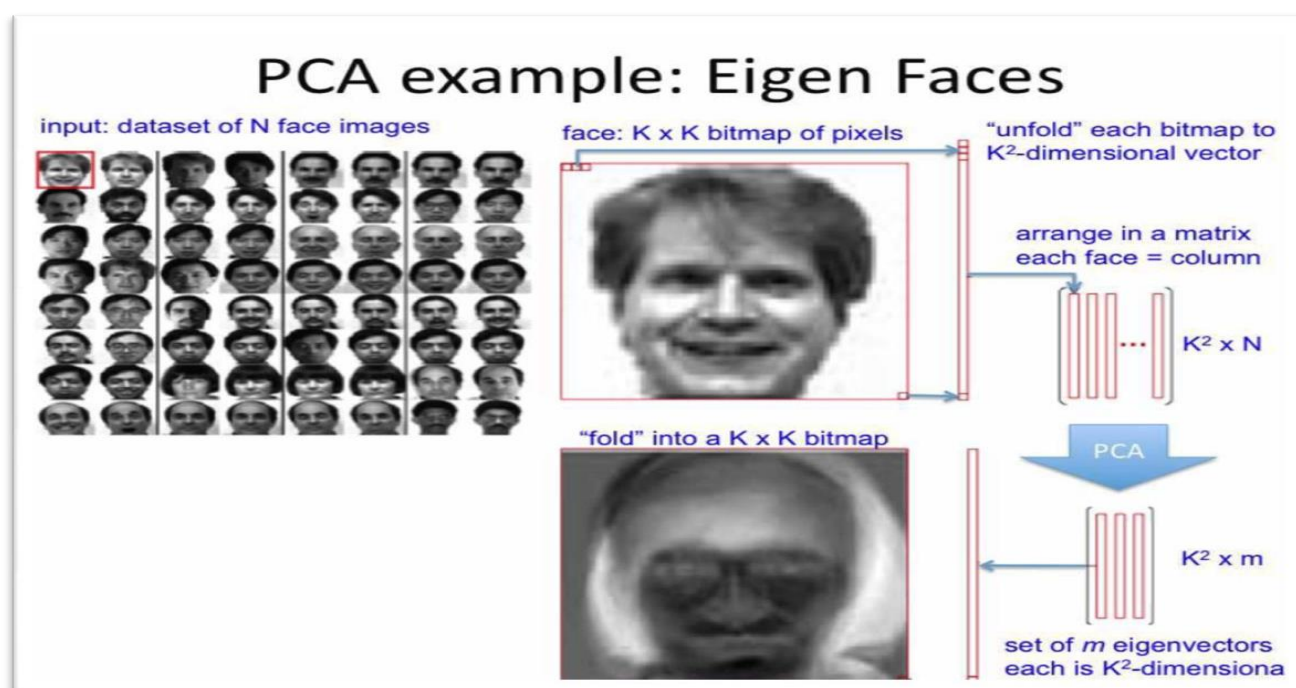

3.3 Eigen Value and Eigen Vector

In linear algebra, the eigenvectors of a linear operator are non-zero vectors which, when operated by the operator, result in a scalar multiple of them. Scalar is then called Eigen value (λ) associated with the eigenvector (X). Eigen vector is a vector that is scaled by linear transformation. It is a property of matrix. When a matrix acts on it, only the vector magnitude is changed not the direction.

$AX = \lambda X$, where A is a vector function.

$(A - \lambda I)X = 0$, where I is the identity matrix.

This is a homogeneous system of equations and form fundamental linear algebra. We know a non-trivial

solution exists if and only if $\text{Det}(A - \lambda I) = 0$, where \det denotes determinant. When evaluated becomes a polynomial of degree n . This is called characteristic polynomial of A . If A is N by N then there are n solutions or n roots of the characteristic polynomial. Thus there are n Eigen values of A satisfying the equation.

$$AX_i = \lambda_i X_i, \text{ where } i = 1, 2, 3, n$$

If the Eigen values are all distinct, there are n associated linearly independent eigenvectors, whose directions are unique, which span an n dimensional Euclidean space.

By calculating the Euclidean distance to the other vectors, how does one know whether the image that is being transformed actually contains a face? Since PCA is a many-to-one transform, several vectors in the image space (images) will map to a point in face space (the problem is that even non-face images may transform near a known face image's faces space vector).), described a simple way of checking whether an image is actually of a face. This is by transforming an image into face space and then transforming it back (reconstructing) into image space. Using the previous notation,

$$I' = U^T * U * (I - A$$

With these calculations it is possible to verify that an image is of a face and recognise that face. did some interesting work on the importance of eigen faces with large and small eigenvalues. They showed that the eigen vectors with larger eigenvalues convey information relative to the basic shape and structure of the faces. This kind of information is most useful in categorising faces according to sex, race etc. Eigen vectors with smaller eigenvalues tend to capture information that is specific to

CHAPTER-4

MATLAB

4.1 INTRODUCTION

The name MATLAB stands for MATrix LABoratory. MATLAB was written originally to provide easy access to matrix software developed by the LINPACK (linear system package) and EISPACK (Eigen system package) projects. MATLAB is a high-performance language for technical computing. It integrates computation, visualization, and programming environment. MATLAB has many advantages compared to conventional computer languages (e.g., C, FORTRAN) for solving technical problems. MATLAB is an interactive system whose basic data element is an array that does not require dimensioning. Specific applications are collected in packages referred to as toolbox. There are tool boxes for signal processing, symbolic computation, control theory, simulation, optimization, and several other fields of applied science and engineering.

4.2 MATLAB's POWER OF COMPUTATIONAL MATHEMATICS

MATLAB is used in every facet of computational mathematics. Following are some commonly used mathematical calculations where it is used most commonly:

- Dealing with Matrices and Arrays
- 2-D and 3-D Plotting and graphics
- Linear Algebra
- Algebraic Equations
- Non-linear Functions
- Statistics
- Data Analysis
- Calculus and Differential Equations Numerical Calculations
- Integration
- Transforms

- Curve Fitting
- Various other special functions

4.3 FEATURES OF MATLAB

Following are the basic features of MATLAB

It is a high-level language for numerical computation, visualization and application development.

- It also provides an interactive environment for iterative exploration, design and problem solving.
- It provides vast library of mathematical functions for linear algebra, statistics, Fourier analysis, filtering, optimization, numerical integration and solving ordinary differential equations.
- It provides built-in graphics for visualizing data and tools for creating custom plots.
- MATLAB's programming interface gives development tools for improving code quality, maintainability, and maximizing performance.
- It provides tools for building applications with custom graphical interfaces.
- It provides functions for integrating MATLAB based algorithms with external applications and languages such as C, Java, .NET and Microsoft Excel.

4.4 USES OF MATLAB

MATLAB is widely used as a computational tool in science and engineering encompassing the fields of physics, chemistry, math and all engineering streams. It is used in a range of applications including:

- signal processing and Communications
- image and video Processing
- control systems
- test and measurement
- computational finance
- computational biology

4.5 UNDERSTANDING THE MATLAB ENVIRONMENT

MATLAB development IDE can be launched from the icon created on the desktop. The main working window in MATLAB is called the desktop. When MATLAB is started, the desktop appears in its default layout.

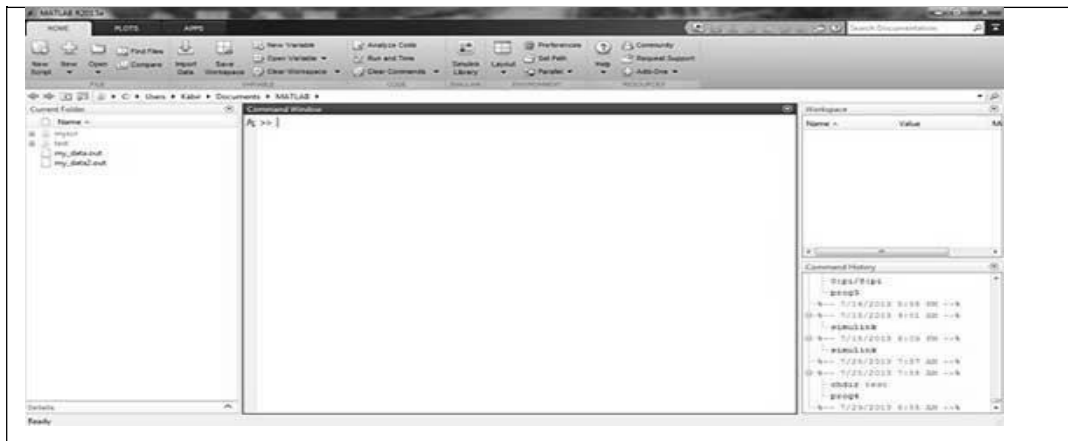

Fig.4.5.1. MATLAB desktop environment

The desktop has the following panels:

Current Folder - This panel allows you to access the project folders and files.

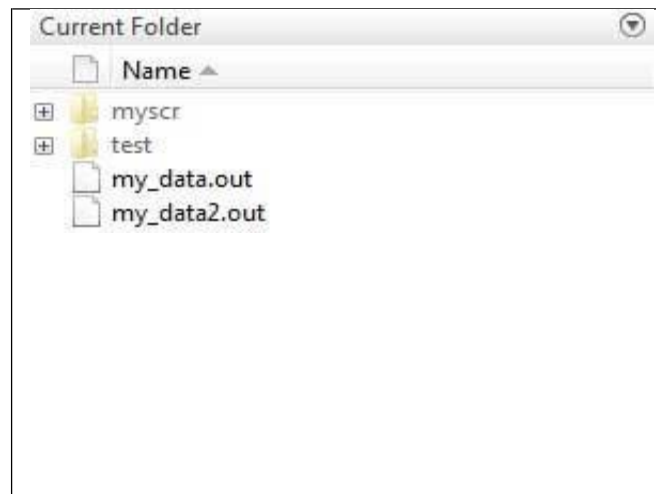

Fig.4.5.2. current folder

Command Window - This is the main area where commands can be entered at the command line. It is indicated by the command prompt (>>).

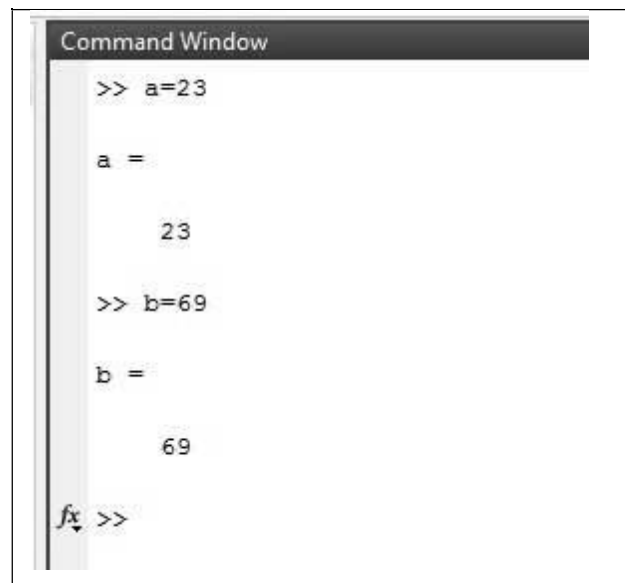

Fig.4.5..3. command window

Workspace - The workspace shows all the variables created and/or imported from files.

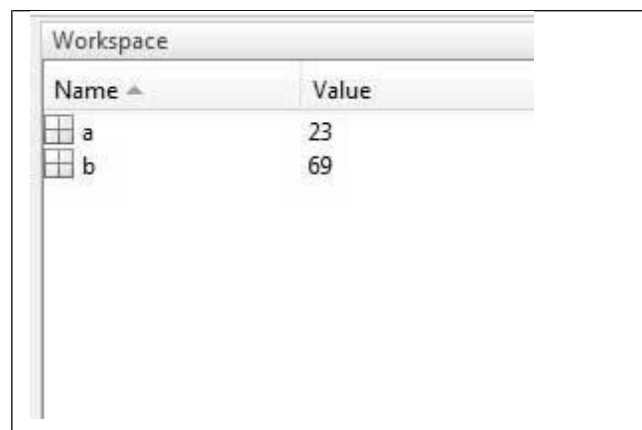

Fig.4.5.4.workspace

Command History - This panel shows or rerun commands that are entered at the command line.

```

-- 7/14/2013 5:58 PM --
-- 7/15/2013 9:01 AM --
simulink
-- 7/15/2013 6:09 PM --
simulink
-- 7/25/2013 7:57 AM --
-- 7/25/2013 7:58 AM --
chdir test
prog4
-- 7/29/2013 8:55 AM --
a=23
b=69

```

Fig.4.5.5 command history

4.6 COMMONLY USED OPERATORS AND SPATIAL CHARATERS

MATLAB supports the following commonly used operators and special characters:

Operator	Purpose
+	Plus; addition operator.
-	Minus, subtraction operator.
*	Scalar and matrix multiplication operator.
.*	Array and multiplication operator.
^	Scalar and matrix exponentiation operator.
.^	Array exponentiation operator.

\	Left-division operator.
/	Right-division operator.
.\	Array left-division operator.
./	Array right-division operator.

Table.4.5.6 MATLAB used operators and special characters.

4.7 COMMANDS

MATLAB is an interactive program for numerical computation and data visualization. You can enter a command by typing it at the MATLAB prompt '>>' on the Command Window.

4.7.1 Commanda for managing a session

MATLAB provides various commands for managing a session. The following table provides all

Commands	Purpose
Clc	Clear command window
Clear	Removes variables from memory
Exist	Checks for existence of file or variable.
Global	Declare variables to be global.
Help	Searches for help topics.
Look for	Searches help entries for a keyword.
Quit	Stops MATLAB.
Who	Lists current variable.
Whos	Lists current variables (Long Display).

Table.4.7.1 commands for managing a session

4.8 INPUT AND OUTPUT COMMAND

MATLAB provides the following input and output related commands:

Command	Purpose
Disp	Displays content for an array or string.
Fscanf	Read formatted data from a file.
Format	Control screen-display format.
Fprintf	Performs formatted write to screen or a file.
Input	Displays prompts and waits for input.
;	Suppresses screen printing.

Table.4.8 input and output commands

4.9 M FILES

MATLAB allows writing two kinds of program files:

Scripts:

script files are program files with .m extension. In these files, you write series of commands, which you want to execute together. Scripts do not accept inputs and do not return any outputs. They operate on data in the workspace.

Functions:

functions files are also program files with .m extension. Functions can accept inputs and return outputs. Internal variables are local to the function.

Creating and Running Script File:

To create scripts files, you need to use a text editor. You can open the MATLAB editor in two ways:

- Using the command prompt
- Using the IDE

You can directly type edit and then the filename (with .m extension).

```

Edit

or

edit<file name>

```

4.10 DATA TYPES AVAILABLE IN MATLAB

MATLAB provides 15 fundamental data types. Every data type stores data that is in the form of a matrix or array. The size of this matrix or array is a minimum of 0-by-0 and this can grow up to a matrix or array of any size.

The following table shows the most commonly used data types in MATLAB:

Datatype	Description
Int8	8-bit signed integer
Unit8	8-bit unsigned integer
Int16	16-bit signed integer
Unit16	16-bit unsigned integer
Int32	32-bit signed integer
unit32	32-bit unsigned integer
Int64	64-bit signed integer
Unit64	64-bit unsigned integer
Single	Single precision numerical data
Double	Double precision numerical data
Logical	Logical variables are 1 or 0, represent true & false respectively
Char	Character data(strings are stored

	as vector of characters)
Call array	Array of indexed calls, each capable of storing array of a different dimension and datatype
Structure	C-like structure each structure having named fields capable of storing an array of a different dimension and datatype
Function handle	Pointer to a function
User classes	Object constructed from a user-defined class
Java classes	Object constructed from a java class

Table.4.10. data types in MATLAB.

CHAPTER-5

FACE DETECTION

The problem of face recognition is all about face detection. This is a fact that seems quite bizarre to new researchers in this area. However, before face recognition is possible, one must be able to reliably find a face and its landmarks. This is essentially a segmentation problem and in practical systems, most of the effort goes into solving this task. In fact the actual recognition based on features extracted from these facial landmarks is only a minor last step.

There are two types of face detection problems:

- 1) Face detection in images and
- 2) Real-time face detection

5.1 FACE DETECTION IN IMAGES

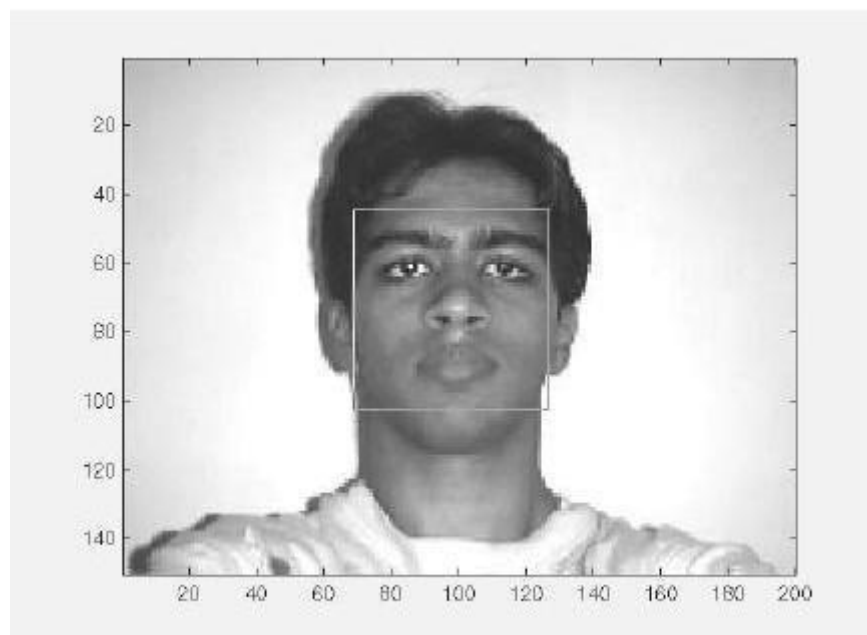

Figure 5.1 A successful face detection in an image with a frontal view of a human face.

Most face detection systems attempt to extract a fraction of the whole face, thereby eliminating most of the background and other areas of an individual's head such as hair that are not necessary for the face recognition task. With static images, this is often done by running a across the image. The face detection system then judges if a face is present inside the window Unfortunately, with static images there is a very large search space of possible locations of a face in an image

Most face detection systems use an example based learning approach to decide whether or not a face is present in the *window* at that given instant. A neural network or some other classifier is trained using supervised learning with 'face' and 'non-face' examples, thereby enabling it to classify an image (*window* in face detection system) as a 'face' or 'non-face'. Unfortunately, while it is relatively easy to find face examples, how would one find a representative sample of images which represent non-faces. Therefore, face detection systems using example based learning need thousands of 'face' and 'non-face' images for effective training. Rowley, Baluja, and Kanade used 1025 face images and 8000 non-face images (generated from 146,212,178 sub-images) for their training set!

There is another technique for determining whether there is a face inside the face detection system's *window* - using Template Matching. The difference between a fixed target pattern (face) and the window is computed and thresholded. If the window contains a pattern which is close to the target pattern(face) then the window is judged as containing a face. An implementation of template matching called Correlation Templates uses a whole bank of fixed sized templates to detect facial features in an image. By using several templates of different (fixed) sizes, faces of different scales (sizes) are detected. The other implementation of template matching is using a deformable template. Instead of using several fixed size templates, we use a deformable template (which is non-rigid) and there by change the size of the template hoping to detect a face in an image.

A face detection scheme that is related to template matching is image invariants. Here the fact that the local ordinal structure of brightness distribution of a face remains largely unchanged under different illumination conditions is used to construct a spatial template of the face which closely corresponds to facial features. In other words, the average grey-scale intensities in human faces are used as a basis for face detection. For example, almost always an individual's eye region is darker than his forehead or nose. Therefore an image will match the template if it satisfies the 'darker than' and 'brighter than' relationships

5.2 REAL-TIME FACE DETECTION

Real-time face detection involves detection of a face from a series of frames from a video-capturing device. While the hardware requirements for such a system are far more stringent, from a computer vision stand point, real-time face detection is actually a far simpler process than detecting a face in a static image. This is because unlike most of our surrounding

environment, people are continually moving. We walk around, blink, fidget, wave our hands about, etc.



Figure 5.2.1: Frame 1 from camera



Figure 5.2.2: Frame 2 from camera



Figure 5.2.3: Spatio-Temporally filtered image

Since in real-time face detection, the system is presented with a series of frames in which to detect a face, by using spatio-temporal filtering (finding the difference between subsequent frames), the area of the frame that has changed can be identified and the individual detected. Further more as seen in Figure exact face locations can be easily identified by using a few simple rules, such as,

- 1) the head is the small blob above a larger blob -the body

2) head motion must be reasonably slow and contiguous -heads won't jump around erratically

Real-time face detection has therefore become a relatively simple problem and is possible even in unstructured and uncontrolled environments using these very simple image processing techniques and reasoning rules.

5.3 FACE DETECTION PROCESS

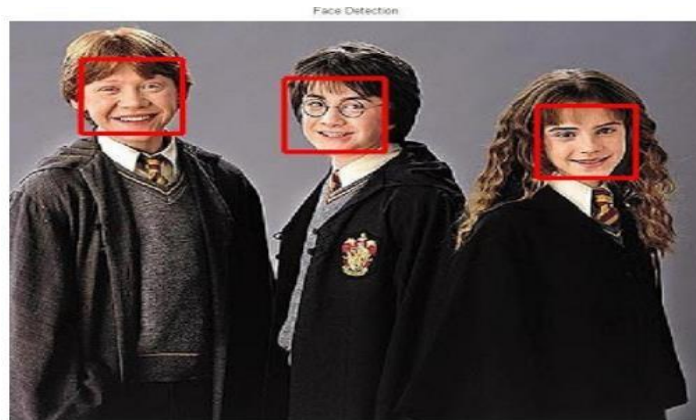
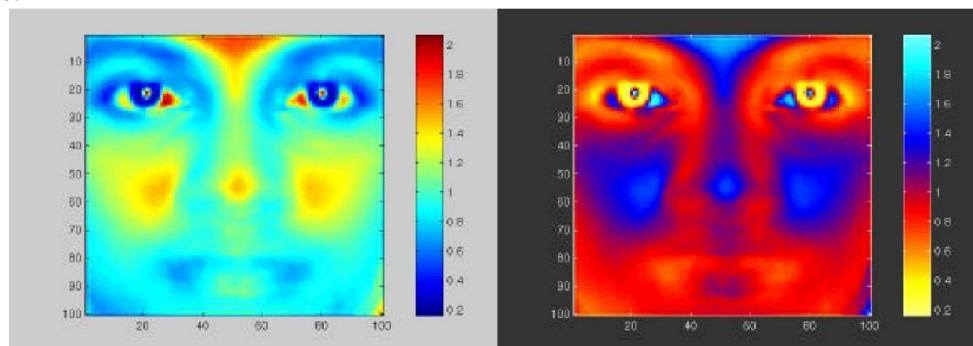

Fig 5.3 Face detection

It is process of identifying different parts of human faces like eyes, nose, mouth, etc... this process can be achieved by using MATLAB code. In this project the author will attempt to detect faces in still images by using image invariants. To do this it would be useful to study the grey-scale intensity distribution of an average human face. The following 'average human face' was constructed from a sample of 30 frontal view human faces, of which 12 were from females and 18 from males. A suitably scaled colormap has been used to highlight grey-scale intensity differences.



scaled colormap

scaled colormap (negative)

Figure 5.3.1 Average human face in grey-scale

The grey-scale differences, which are invariant across all the sample faces are strikingly apparent. The eye-eyebrow area seem to always contain dark intensity (low) gray-levels while nose forehead and cheeks contain bright intensity (high) grey-levels. After a great deal of experimentation, the researcher found that the following areas of the human face were suitable for a face detection system based on image invariants and a deformable template.

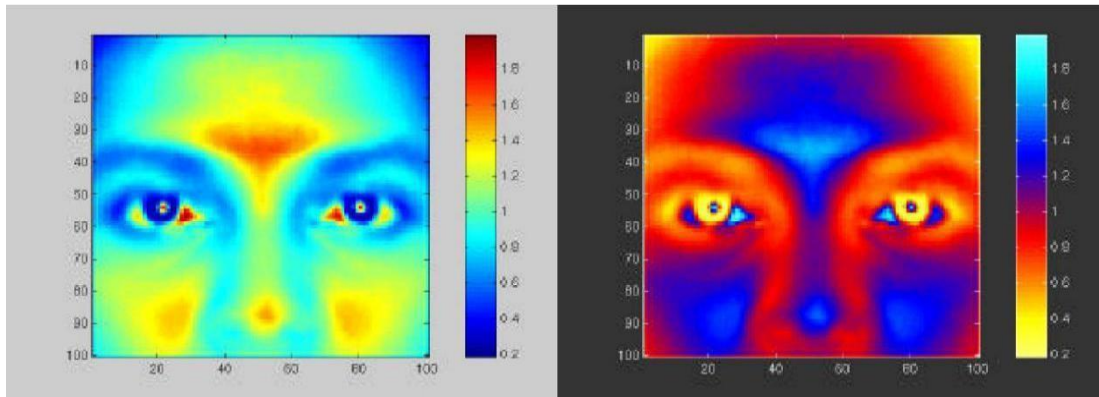

scaled colormap

scaled colormap (negative)

Figure 5.3.2 Area chosen for face detection (indicated on average human face in gray scale)

The above facial area performs well as a basis for a face template, probably because of the clear divisions of the bright intensity invariant area by the dark intensity invariant regions. Once this pixel area is located by the face detection system, any particular area required can be segmented based on the proportions of the average human face. After studying the above images it was subjectively decided by the author to use the following as a basis for dark intensity sensitive and bright intensity sensitive templates. Once these are located in a subject's face, a pixel area 33.3% (of the width of the square window) below this.

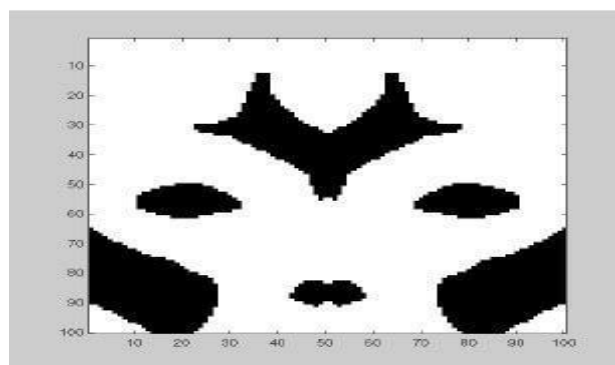

Figure 5.3.3: Basis for a bright intensity invariant sensitive template.

Note the slight differences which were made to the bright intensity invariant sensitive template (compare Figures 3.4 and 3.2) which were needed because of the pre-processing done by

the system to overcome irregular lighting (chapter six). Now that a suitable dark and bright intensity invariant templates have been decided on, it is necessary to find a way of using these to make 2 A-units for a perceptron, i.e. a computational model is needed to assign neurons to the distributions displayed .

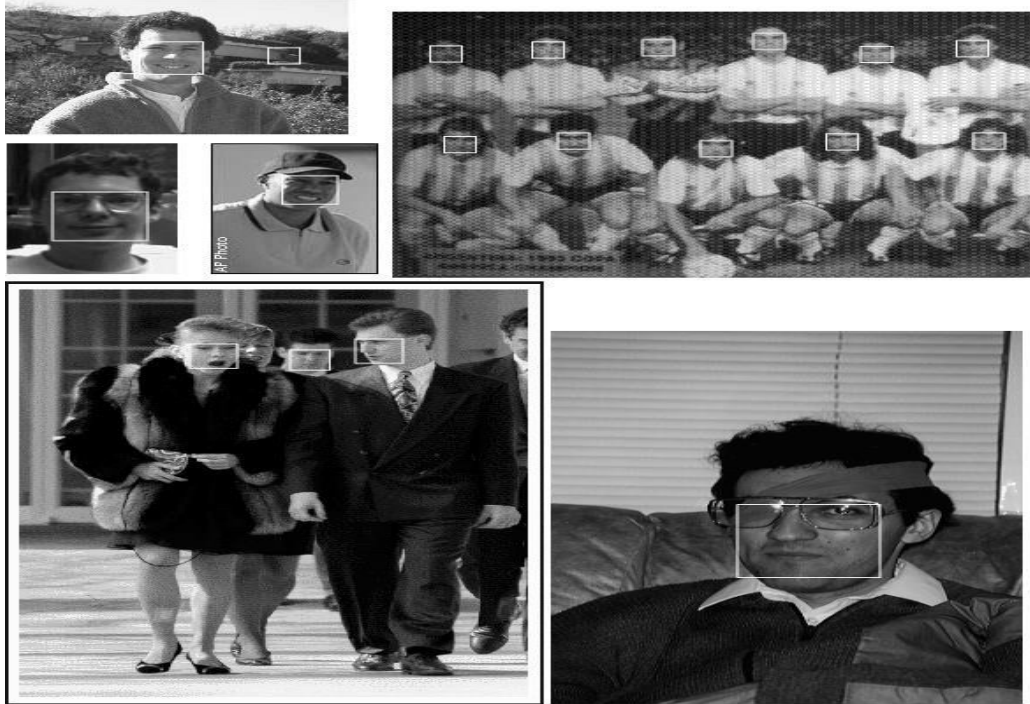

Fig 5.3.4 Scanned image detection

- Scan window over image
- Classify window as either
 1. Face
 2. Non - Face

5.4 FACE DETECTION ALGORITHM

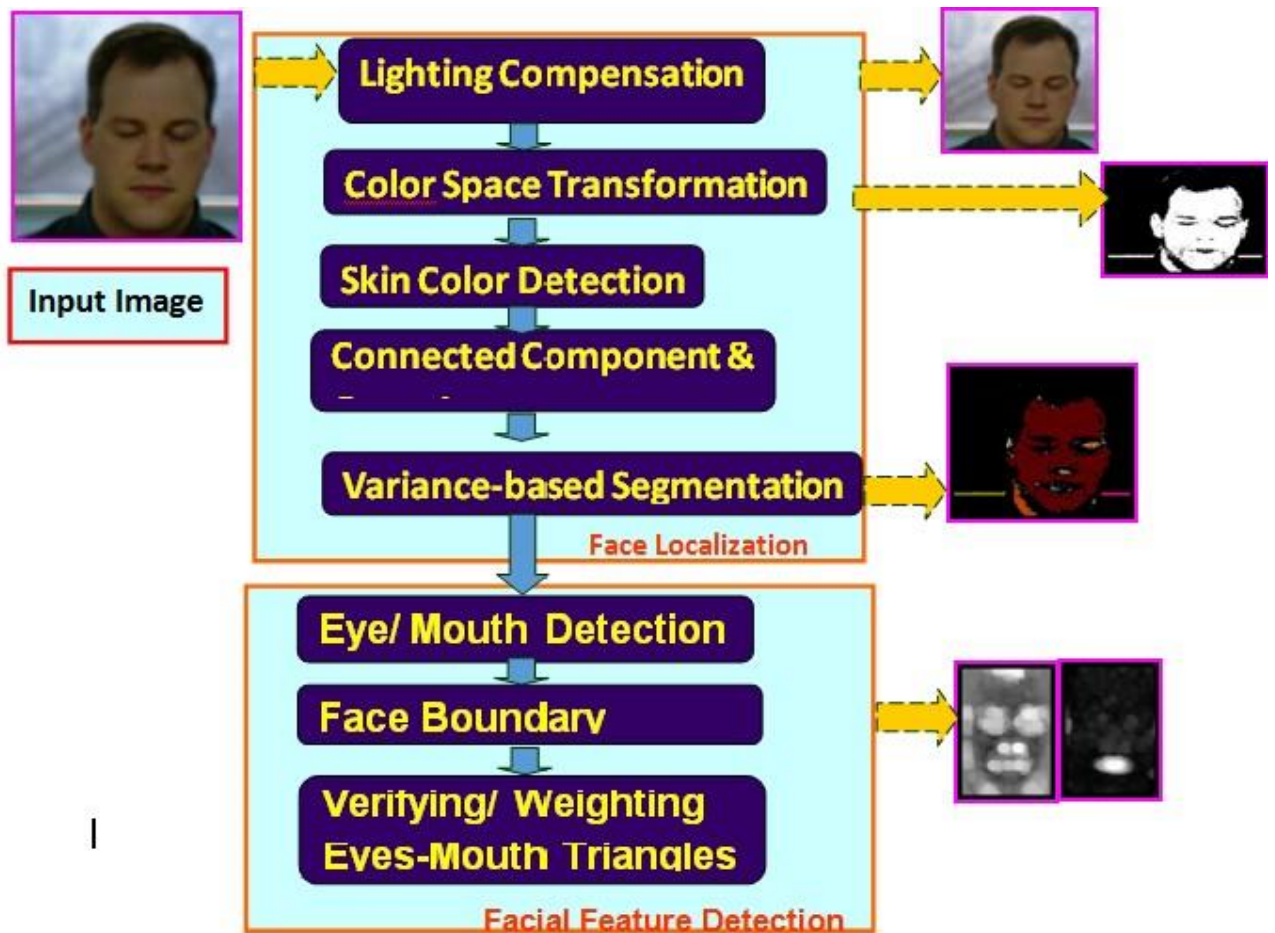

Fig 5.4 Face detection algorithm



Fig 5.4.1 mouth detection

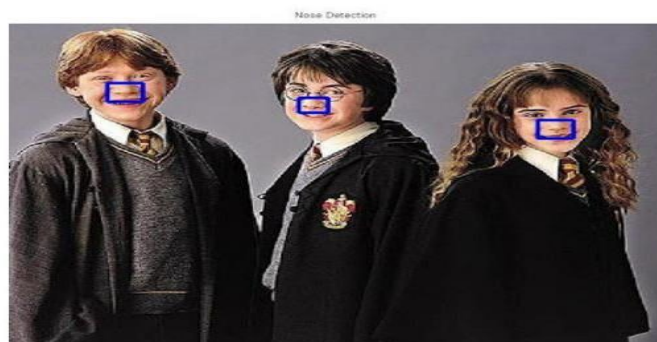

Fig 5.4.2 Noise detection

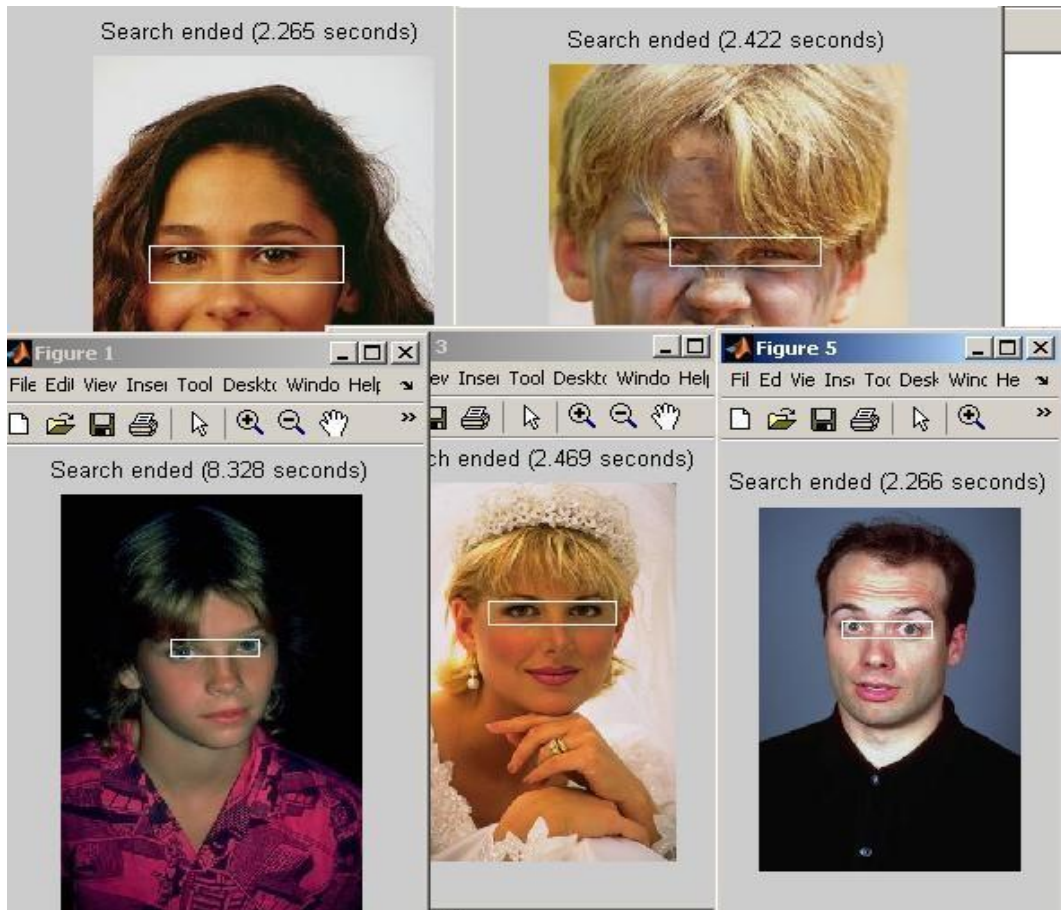

Fig 5.4.3 Eye detection

CHAPTER-6

FACE RECOGNITION

Over the last few decades many techniques have been proposed for face recognition. Many of the techniques proposed during the early stages of computer vision cannot be considered successful, but almost all of the recent approaches to the face recognition problem have been creditable. According to the research by Brunelli and Poggio (1993) all approaches to human face recognition can be divided into two strategies:

- (1) Geometrical features and
- (2) Template matching.

6.1 FACE RECOGNITION USING GEOMETRICAL FEATURES

This technique involves computation of a set of geometrical features such as nose width and length, mouth position and chin shape, etc. from the picture of the face we want to recognize. This set of features is then matched with the features of known individuals. A suitable metric such as Euclidean distance (finding the closest vector) can be used to find the closest match. Most pioneering work in face recognition was done using geometric features (Kanade,), although Craw et al. did relatively recent work in this area.

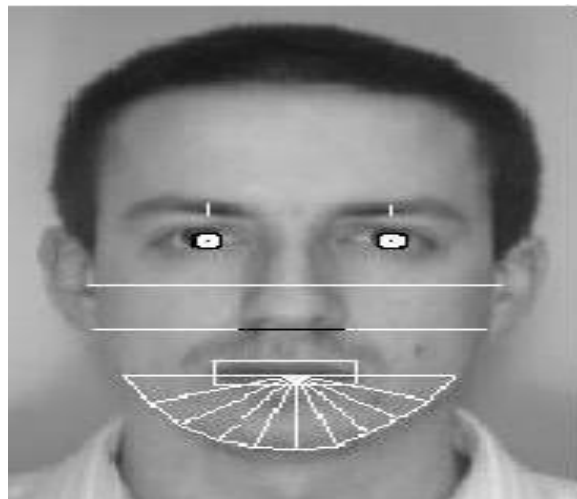

Figure 6.1 Geometrical features (white) which could be used for face recognition

The advantage of using geometrical features as a basis for face recognition is that recognition is possible even at very low resolutions and with noisy images (images with many disorderly pixel intensities). Although the face cannot be viewed in detail its overall geometrical configuration can be extracted for face recognition. The technique's main disadvantage is that automated extraction of the facial geometrical features is very hard. Automated geometrical

feature extraction based recognition is also very sensitive to the scaling and rotation of a face in the image plane . This is apparent when we examine results where he reported a recognition rate of between 45-75 % with a database of only 20 people. However if these features are extracted manually as in (satisfactory results may be obtained.)

6.1.1 Face recognition using template matching

This is similar the template matching technique used in face detection, except here we are not trying to classify an image as a 'face' or 'non-face' but are trying to recognize a face.

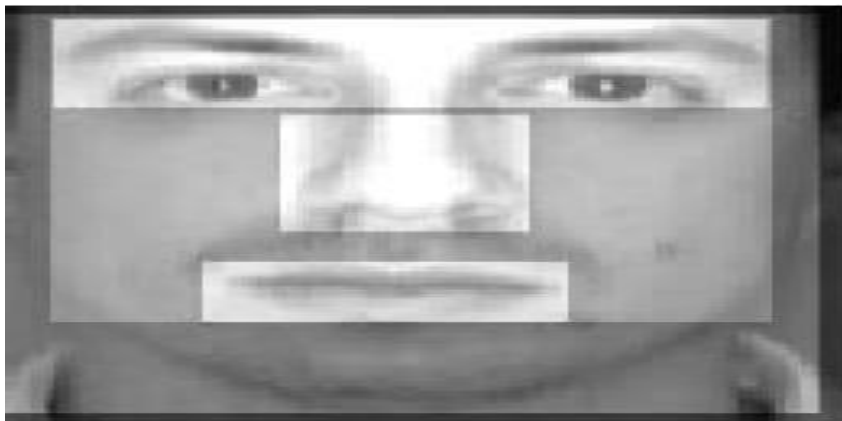

Figure .6.11 Face recognition using template matching

Whole face, eyes, nose and mouth regions which could be used in a template matching strategy. The basis of the template matching strategy is to extract whole facial regions (matrix of pixels) and compare these with the stored images of known individuals. Once again Euclidean distance can be used to find the closest match. The simple technique of comparing grey-scale intensity values for face recognition was used by Baron . However there are far more sophisticated methods of template matching for face recognition. These involve extensive pre- processing and transformation of the extracted grey-level intensity values. For example, Turk and Pentland used Principal Component Analysis, sometimes known as the eigenfaces approach, to pre-process the gray-levels and used Elastic Graphs encoded using Gabor filters to pre-process the extracted regions. An investigation of geometrical features versus template matching for face recognition by Brunelli and Poggio came to the conclusion that although a feature based strategy may offer higher recognition speed and smaller memory requirements, template based techniques offer superior recognition accuracy.

6.2 PROBLEM SCOP AND SYSTEM SPECIFICATION

The following problem scope for this project was arrived at after reviewing the literature on face detection and face recognition, and determining possible real-world situations where such systems would be of use. The following system(s) requirements were identified

- 1 A system to detect frontal view faces in static images
- 2 A system to recognize a given frontal view face
- 3 Only expressionless, frontal view faces will be presented to the face detection&recognition
- 4 All implemented systems must display a high degree of lighting invariency.
- 5 All systems must posses near real-time performance.
- 6 Both fully automated and manual face detection must be supported
- 7 Frontal view face recognition will be realised using only a single known image
- 8 Automated face detection and recognition systems should be combined into a fully automated face detection and recognition system. The face recognition sub-system must display a slight degree of invariency to scaling and rotation errors in the segmented image extracted by the face detection sub-system.
- 9 The frontal view face recognition system should be extended to a pose invariant face recognition system.

Unfortunately although we may specify constricting conditions to our problem domain, it may not be possible to strictly adhere to these conditions when implementing a system in the real-world.

6.3 BRIEF OUT LINE OF THE IMPLEMENTED SYSTEM

Fully automated face detection of frontal view faces is implemented using a deformable template algorithm relying on the image invariants of human faces. This was chosen because a similar neural-network based face detection model would have needed far too much training data to be implemented and would have used a great deal of computing time. The main difficulties in implementing a deformable template based technique were the creation of the bright and dark intensity sensitive templates and designing an efficient implementation of the detection algorithm.

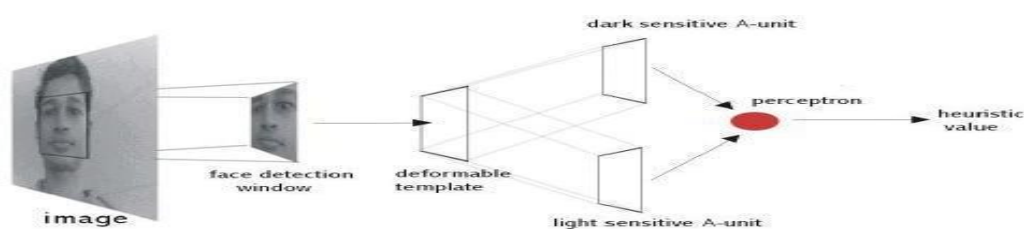

Figure 6.3 Implemented fully automated frontal view face detection model

A manual face detection system was realised by measuring the facial proportions of the average face, calculated from 30 test subjects. To detect a face, a human operator would identify the locations of the subject's eyes in an image and using the proportions of the average face, the system would segment an area from the image

A template matching based technique was implemented for face recognition. This was because of its increased recognition accuracy when compared to geometrical features based techniques and the fact that an automated geometrical features based technique would have required complex feature detection pre-processing.

Of the many possible template matching techniques, Principal Component Analysis was chosen because it has proved to be a highly robust in pattern recognition tasks and because it is relatively simple to implement. The author would also liked to have implemented a technique based on Elastic Graphs but could not find sufficient literature about the model to implement such a system during the limited time available for this project.

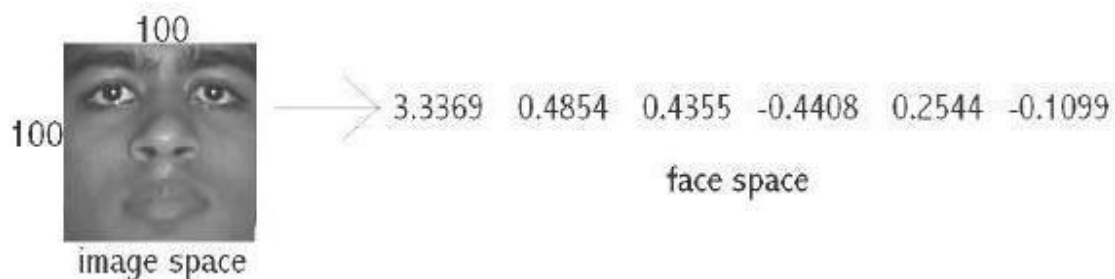

Figure 6.3.1: Principal Component Analysis transform from 'image space' to 'face space'.

Using Principal Component Analysis, the segmented frontal view face image is transformed from what is sometimes called 'image space' to 'face space'. All faces in the face database are transformed into face space. Then face recognition is achieved by transforming any given test image into face space and comparing it with the training set vectors. The closest matching training set vector should belong to the same individual as the test image. Principal Component Analysis is of special interest because the transformation to face space is based on the variation of human faces (in the training set). The values of the 'face space' vector correspond to the amount certain 'variations' are present in the test image

Face recognition and detection system is a pattern recognition approach for personal identification purposes in addition to other biometric approaches such as fingerprint recognition, signature, retina and so forth. Face is the most common biometric used by humans applications ranges from static, mug-shot verification in a cluttered background.



Fig 6.3.2 Face Recognition

6.4 FACE RECOGNITION DIFFICULTIES

1. Identify similar faces (inter-class similarity)
2. Accommodate intra-class variability due to
 - 2.1 head pose
 - 2.2 illumination conditions
 - 2.3 expressions
 - 2.4 facial accessories
 - 2.5 aging effects
3. Cartoon faces

6.4.1 Inter - class similarity:

- Different persons may have very similar appearance



Fig 6.4.1 Face recognition twins and other and Son

Face recognition and detection system is a pattern recognition approach for personal identification purposes in addition to other biometric approaches such as fingerprint recognition, signature, retina and so forth. The variability in the faces, the images are processed before they are fed into the network. All positive examples that is the face images are obtained by cropping images with frontal faces to include only the front view. All the cropped images are then corrected for lighting through standard algorithms.

6.4.2 Inter – class variability

Faces with intra-subject variations in pose, illumination, expression, accessories, color, occlusions, and brightness

6.5 PRINCIPAL COMPONENT ANALYSIS (PCA)

Principal Component Analysis (or Karhunen-Loeve expansion) is a suitable strategy for face recognition because it identifies variability between human faces, which may not be immediately obvious. Principal Component Analysis (hereafter PCA) does not attempt to categorise faces using familiar geometrical differences, such as nose length or eyebrow width. Instead, a set of human faces is analysed using PCA to determine which 'variables' account for the variance of faces. In face recognition, these variables are called eigen faces because when plotted they display an eerie resemblance to human faces. Although PCA is used extensively in statistical analysis, the pattern recognition community started to use PCA for classification only relatively recently. As described by Johnson and Wichern, 'principal component analysis is concerned with explaining the variance-covariance structure through a few linear combinations of the original variables.' Perhaps PCA's greatest strengths are in its ability for data reduction and interpretation. For example a 100x100 pixel area containing a face can be very accurately represented by just 40 eigen values. Each eigen value describes the magnitude of each eigen face in each image. Furthermore, all interpretation (i.e. recognition) operations can now be done using just the 40 eigen values to represent a face instead of the manipulating the 10000 values contained in a 100x100 image. Not only is this computationally less demanding but the fact that the recognition information of several thousand.

6.6 UNDERSTANDING EIGENFACES

Any grey scale face image $I(x,y)$ consisting of a $N \times N$ array of intensity values may also be considered as a vector of N^2 . For example, a typical 100x100 image used in this thesis will have to be transformed into a 10000 dimension vector!

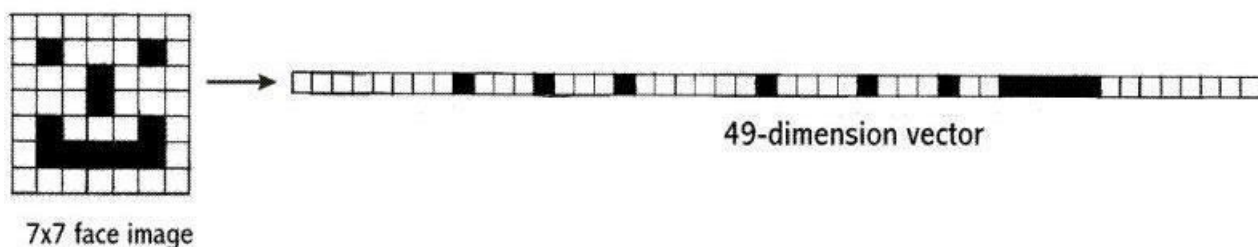

Figure 6.6.0 A 7x7 face image transformed into a 49 dimension vector

This vector can also be regarded as a point in 10000 dimension space. Therefore, all the images of subjects' whose faces are to be recognized can be regarded as points in 10000 dimension

space. Face recognition using these images is doomed to failure because all human face images are quite similar to one another so all associated vectors are very close to each other in the 10000-dimension space.

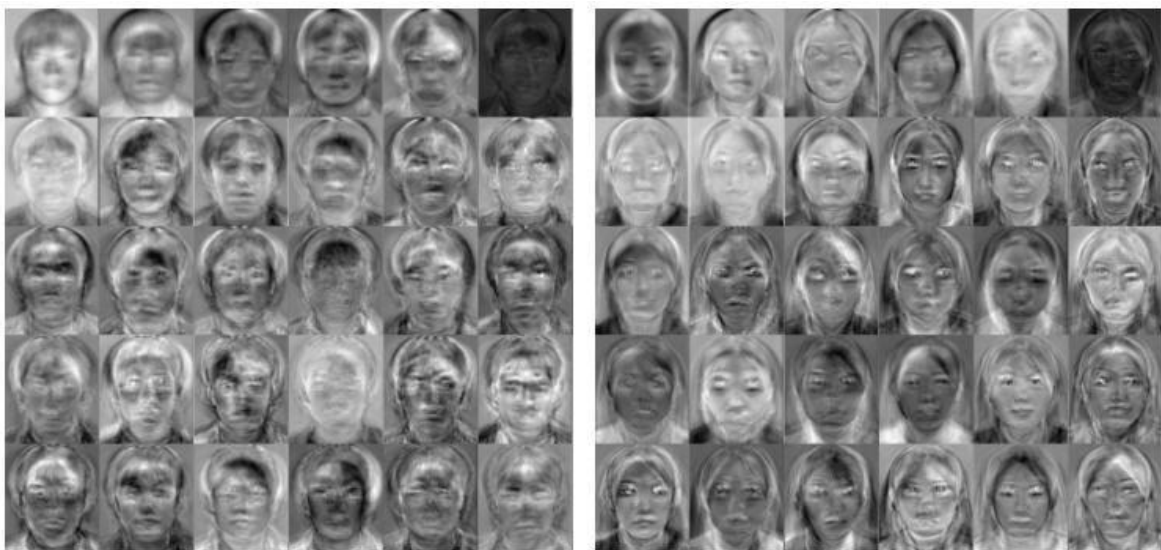
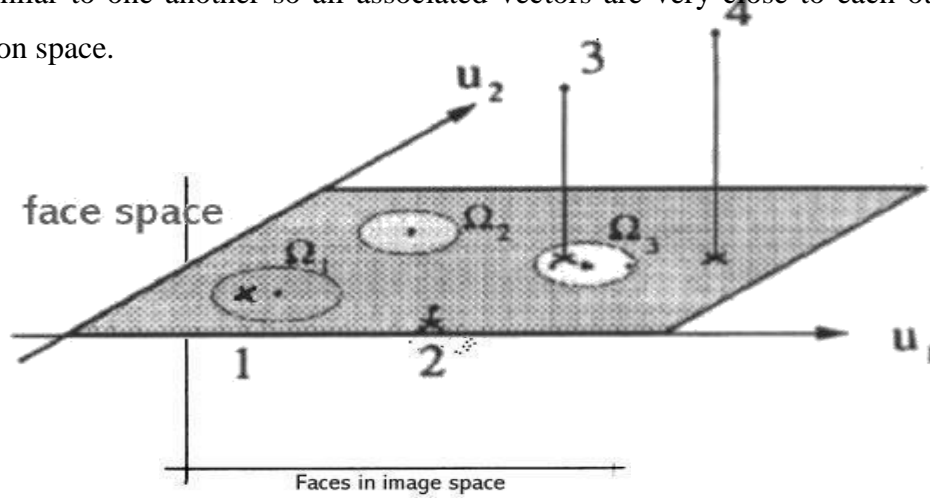

Fig 6.6.1 Eigenfaces

The transformation of a face from image space (I) to face space (f) involves just a simple matrix multiplication. If the average face image is A and U contains the (previously calculated) eigenfaces,

$$f = U * (I - A)$$

This is done to all the face images in the face database (database with known faces) and to the image (face of the subject) which must be recognized. The possible results when projecting a face into face space are given in the following figure.

There are four possibilities:

1. Projected image is a face and is transformed near a face in the face database
2. Projected image is a face and is not transformed near a face in the face database
3. Projected image is not a face and is transformed near a face in the face database
4. Projected image is not a face and is not transformed near a face in the face database

While it is possible to find the closest known face to the transformed image face by calculating the Euclidean distance to the other vectors, how does one know whether the image that is being transformed actually contains a face? Since PCA is a many-to-one transform, several vectors in the image space (images) will map to a point in face space (the problem is that even non-face images may transform near a known face image's faces space vector). Turk and Pentland , described a simple way of checking whether an image is actually of a face. This is by transforming an image into face space and then transforming it back (reconstructing) into image space. Using the previous notation,

$$I' = U^T * U * (I - A)$$

With these calculations it is possible to verify that an image is of a face and recognise that face. O'Toole et al. did some interesting work on the importance of eigen faces with large and small eigenvalues. They showed that the eigen vectors with larger eigenvalues convey information relative to the basic shape and structure of the faces. This kind of information is most useful in categorising faces according to sex, race etc. Eigen vectors with smaller eigenvalues tend to capture information that is specific to single or small subsets of learned faces and are useful for distinguishing a particular face from any other face. Turk and Pentland (1991a) showed that about 40 eigen faces were sufficient for a very good description of human faces since the reconstructed image have only about 2% RMS. pixel-by-pixel errors.

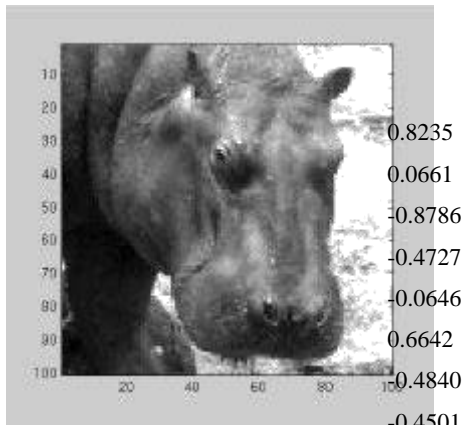

Hippo in image space

0.8235
0.0661
-0.8786
-0.4727
-0.0646
0.6642
-0.4840
-0.4501
-0.2506
0.1591
0.3359
0.0048
0.0745
.....

Hippo in face space

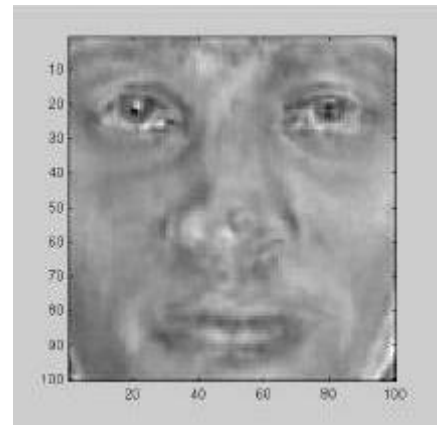

Reconstructed hippo in image space

0.7253
-0.0392
0.2896
-0.1725
-0.2642
-0.0014
-0.0814
-0.0054
-0.0623
-0.0965
-0.0879
0.0745
-0.0261
.....

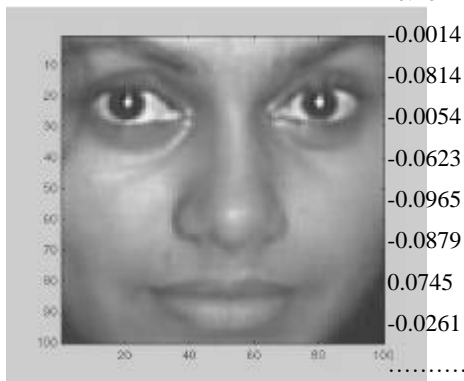

Face in image space

Face in face space

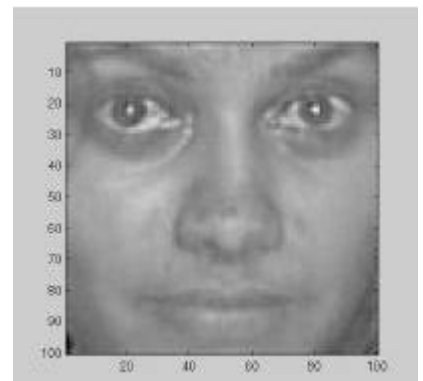

Reconstructed face in image space

Figure 6.6.3 Images and their reconstruction. The Euclidean distance between a face image and its reconstruction will be lower than that of a non-face image

6.7 IMPROVING FACE DETECTION USING RECONSTRUCTIN

Reconstruction cannot be used as a means of face detection in images in near real-time since it would involve resizing the face detection *window* area and large matrix multiplication, both of which are computationally expensive. However, reconstruction can be used to verify whether potential face locations identified by the deformable template algorithm actually contain a face. If the reconstructed image differs greatly from the face detection *window* then the *window* probably does not contain a face. Instead of just identifying a single potential face location, the face detection algorithm can be modified to output many high 'faceness' locations which can be verified using reconstruction. This is especially useful because occasionally the best 'faceness' location found by the deformable template algorithm may not contain the ideal frontal view face pixel area.

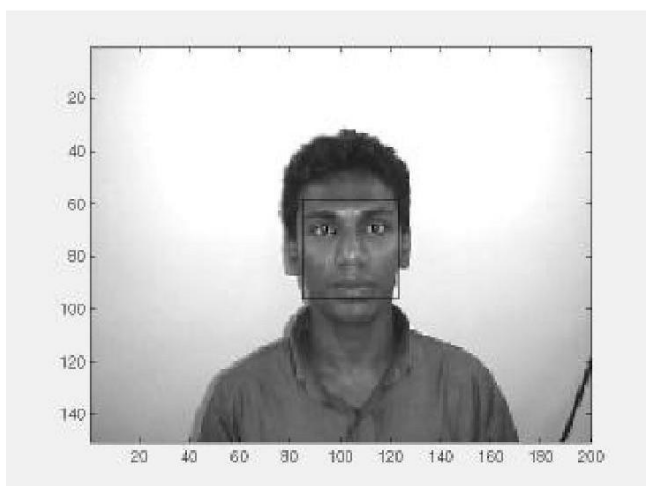

Output from Face detection system

Heuristic	x	y	width
978	74	31	60
1872	74	33	60
1994	75	32	58
2125	76	32	56
2418	76	34	56
2389	79	32	50
2388	80	33	48
2622	81	33	46
2732	82	32	44
2936	84	33	40
2822	85	58	38
2804	86	60	36
2903	86	62	36
3311	89	62	30
3373	91	63	26
3260	92	64	24
3305	93	64	22
3393	94	65	20

potential face locations that have been identified by the face detection system (the best face locations it found on its search) are checked whether they contain a face. If the threshold level (maximum difference between reconstruction and original for the original to be a face) is set correctly this will be an efficient way to detect a face. The deformable template algorithm is fast and can reduce the search space of potential face locations to a handful of positions. These are then checked using reconstruction. The number of locations found by the face detection system can be changed by getting it to output, not just the best face locations it has found so far but any location, which has a 'faceness' value, which for example is, at least 0.9 times the best heuristic value that has been found so far. Then there will be many more potential face locations to be checked using reconstruction. This and similar speed versus accuracy trade-off decisions have to be made keeping in mind the platform on which the system is implemented.

Similarly, instead of using reconstruction to check the face detection system's output, the output's correlation with the average face can be checked. The segmented areas with a high correlation probably contains a face. Once again a threshold value will have to be established to classify faces from non-faces. Similar to reconstruction, resizing the segmented area and calculating its correlation with the average face is far too expensive to be used alone for face detection but is suitable for verifying the output of the face detection system.

6.8 POSE INVARIANT FACE RECOGNITION

Extending the frontal view face recognition system to a pose-invariant recognition system is quite simple if one of the proposed specifications of the face recognition system is relaxed. Successful pose-invariant recognition will be possible if many images of a known individual are in the face database. Nine images from each known individual can be taken as shown below. Then if an image of the same individual is submitted within a 30° angle from the frontal view he or she can be identified.

Nine images in face database from a single known individual



Unknown image from same individual to be identified



Fig: 6.8 Pose invariant face recognition.

Pose invariant face recognition highlights the generalisation ability of PCA. For example, when an individual's frontal view and 30° left view known, even the individual's 15° left view can be recognised

CONCLUSION

The computational models, which were implemented in this project, were chosen after extensive research, and the successful testing results confirm that the choices made by the researcher were reliable. The system with manual face detection and automatic face recognition did not have a recognition accuracy over 90%, due to the limited number of eigenfaces that were used for the PCA transform. This system was tested under very robust conditions in this experimental study and it is envisaged that real-world performance will be far more accurate. The fully automated frontal view face detection system displayed virtually perfect accuracy and in the researcher's opinion further work need not be conducted in this area.

The fully automated face detection and recognition system was not robust enough to achieve a high recognition accuracy. The only reason for this was the face recognition subsystem did not display even a slight degree of invariance to scale, rotation or shift errors of the segmented face image. This was one of the system requirements identified in section 2.3. However, if some sort of further processing, such as an eye detection technique, was implemented to further normalise the segmented face image, performance will increase to levels comparable to the manual face detection and recognition system. Implementing an eye detection technique would be a minor extension to the implemented system and would not require a great deal of additional research. All other implemented systems displayed commendable results and reflect well on the deformable template and Principal Component Analysis strategies. The most suitable real-world applications for face detection and recognition systems are for mugshot matching and surveillance. There are better techniques such as iris or retina recognition and face recognition using the thermal spectrum for user access and user verification applications since these need a very high degree of accuracy. The real-time automated pose invariant face detection and recognition system proposed in chapter seven would be ideal for crowd surveillance applications. If such a system were widely implemented its potential for locating and tracking suspects for law enforcement agencies is immense.

The implemented fully automated face detection and recognition system (with an eye detection system) could be used for simple surveillance applications such as ATM user security, while the implemented manual face detection and automated recognition system is ideal of mugshot matching. Since controlled conditions are present when mugshots are gathered, the frontal view face recognition scheme should display a recognition accuracy far better than the results, which were obtained in this study, which was conducted under adverse conditions.

Furthermore, many of the test subjects did not present an expressionless, frontal view to the system. They would probably be more compliant when a 6'5" policeman is taking their mugshot! In mugshot matching applications, perfect recognition accuracy or an exact match is not a requirement. If a face recognition system can reduce the number of images that a human operator has to search through for a match from 10000 to even a 100, it would be of incredible practical use in law enforcement.

The automated vision systems implemented in this thesis did not even approach the performance, nor were they as robust as a human's innate face recognition system. However, they give an insight into what the future may hold in computer vision.

REFERANCE

- Adelson, E. H., and Bergen, J. R. (2006) The Extraction of Spatio-Temporal Energy in Human face recognition using (ISJR)
- Principal component analysis(https://en.wikipedia.org/wiki/Principal_component_analysis)
- <https://setosa.io/ev/principal-component-analysis>
- <https://georgemdallas.wordpress.com/2013/10/30/principal-component-analysis-4-dummies-eigenvalues-and-dimension-reduction/>
- Human and Machine Vision, Proceedings of Workshop on Motion: Representation and
- A newsletter from the American Academy of Facial Plastic and Reconstructive Surgery.
- Baron, R. J. Mechanisms of human facial recognition. International Journal of Man Machine Studies,
- Bichsel, M. (Strategies of Robust Objects Recognition for Automatic Identification of Human Faces. PhD thesis, , Eidgenossischen Technischen Hochschule, Zurich.
- Dunteman, G.HPrincipal Component Analysis. Sage Publications.
Gauthier, I., Behrmann, M. and Tarr, M. Can face recognition really be dissociated from object recognition? Journal of Cognitive Neuroscience, in press.
- Goldstein, A.J., Harmon, L.D., and Lesk, Identification of human faces. In Proc. IEEE,
- de Haan, M., Johnson, M.H. and Maurer D. (Recognition of individual faces and average face prototypes by 1- and 3- month-old infants. Centre for Brain and Cognitive
- Introduction to eigen faces and eigen vector (<https://pathmind.com/wiki/eigenvector>)

□