

**MODELLING AND SIMULATION OF MEMS TYPE
PRESSURE SENSOR**

Submitted in partial fulfillment of the requirements

Of the degree of

MASTER OF TECHNOLOGY

IN

MECHATRONICS

By

SHIVAM SHARMA (18032020043)

Under the guidance of

Dr. Swet Chandan



**SCHOOL OF MECHANICAL ENGINEERING
GALGOTIAS UNIVERSITY
GREATER NOIDA
2019**

Certificate

This is to certify that the research work titled “**MODELLING AND SIMULATION OF MEMS TYPE PRESSURE SENSOR**” that is being submitted by **Shivam Sharma** is in partial fulfilment of the requirements for the award of **Masters of Technology**, is a bonified work done under my guidance. All help received by her from various sources have been duly acknowledged. The work done for this research work, in full or in parts, have neither been taken from any other source nor it have been submitted to any other institute or university for award of any degree or diploma.

Guide

Internal Examiner

External Examine

Approval Sheet

This thesis/dissertation/project report entitled “**MODELLING AND SIMULATION OF MEMS TYPE PRESSURE SENSOR**” by “**Shivam Sharma**” is approved for the degree of master of technology in mechanical engineering.

Examiners

Guide

Dean

Date: _____

Place: _____

Declaration

I declare that this written submission represents my ideas in my own words and where others' ideas or words have been included, I have adequately cited and referenced the original sources. I also declare that I have followed by all principles of academic loyalty and integrity and have not misrepresented or fabricated or falsified any idea/data/fact/source in my submission. I understand that if any violation of the above will lead for disciplinary action by the Institute and can also evoke hard action from the sources which result in not been properly cited or from whom proper permission has not been taken when needed.

(Signature)

(Name of the student)

(Enrolment No.)

Date: _____

Acknowledgement

I would like to extend my gratitude to my sir “Dr. Swet Chandan” and his passion for the learning and accepting new challenges always give me to motivation for learning about new areas for strongly believing me and supported me in every phase. My completion of this project could not have been accomplished without the support of my friend Yashwardhan Sahi for encouraging me and turns positivity all around.

Finally, to my caring, loving and supportive family: my deepest gratitude. Your encouragement when the times got rough are much appreciated and duly noted. Also I would like to thanks all the faculties of Galgotias University for helping me in their possible ways.

(Shivam Sharma)

(Department of Mechanical Engineering)

Abstract

Accurate measurement of pressure is a widely used application of MEMS pressure sensor. Piezoresistive pressure sensors have been widely used in various fields such as in industries, automotive, auto- mobiles, aeronautical and many others. The sensor behaviour is basically depended upon its thickness, area, material properties etc. This project is based on the piezoresistive pressure sensor which made of silicon material poses higher sensitivity. Using FEA (finite element analysis) and software ANSYS18 the simulation result has been taken. The sensitivity result is based on different dimensions with different environment condition. The patterns of piezoresistors of silicon material are arranged in different patterns. The variation of the thickness of the diaphragm and piezoresistive is done to study its effect on performance of MEMS based piezoresistive pressure sensor. With the result, the best design for the sensor is been considered.

Table of Content

	<i>Page</i>
Certificate	II
Approval Sheet	III
Student Declaration	IV
Acknowledgement	V
Abstract	VI
Table of Content	VII
List of Figures	IX
List of Tables	X
List of Abbreviation	XI
Chapter 1 Introduction	1
1.1 Importance of the Research	1
1.2 Thesis Contributions	2
1.3 Thesis Outline	2
1.4 Layout	3
Chapter 2 Literature Review	6
2.1 Reviews	6
Chapter 3 Parameter and Design	10
3.1 Introduction	10
3.2 Diaphragm Details	11
3.2.1 Design of Diaphragm	11
3.2.2 Pattern of Diaphragm	16
3.3 Piezoresistors Details	18
3.3.1 Piezoresistors Shape	18
3.3.2 Size of Piezoresistors	19
3.4 Modelling of Piezoresistors	19
3.5 Finite Element Analysis	22
3.6 Mathematical Expression	23

Chapter 4	Results and Discussion	26
4.1	Simulation Result	26
Chapter 5	Conclusions and Recommendations	27
5.1	Conclusions	27
5.2	Recommendations	27
References		28

List of Figures

FIGURE	LABELS	PAGE NO
Figure 1	Arrangement of piezoresistors	4
Figure 2	Structure of diaphragm	5
Figure 3	Piezoresistive pressure sensor.	7
Figure 4	piezoresistors on diaphragm	11
Figure 5	Max stress	12
Figure 6	Pressure variation Vs M. Stress	12
Figure 7	Maximum Principal stress	12
Figure 8	Pressure variation Vs P. Stress	12
Figure 9	Figure showing Total deformation	13
Figure 10	Pressure variation Vs Total deformation	13
Figure 11	Figure showing Equivalent stress	13
Figure 12	Pressure variation Vs. M. Stress	13
Figure 13	Max principal stress	14
Figure 14	Pressure variation Vs P.Stress	14
Figure 15	Figure showing Total deformation	14
Figure 16	Pressure variation Vs Total deformation	14
Figure 17	Max stress	15
Figure 18	Pressure variation Vs M.Stress	15
Figure 19	Max Principal stress	15
Figure 20	Pressure variation Vs P. Stress	15
Figure 21	Figure showing Total deformation	16
Figure 22	Pressure variation Vs Total deformation	16
Figure 23	Pattern of Diaphragm with different arrangement of piezoresisto	16
Figure 24	Arrangement of Piezoresistors in Wheatstone bridge	17
Figure 25	a) Square shaped piezoresistors. b) Pentagon shaped piezoresistc c)Hexagon shaped piezoresistors	18
Figure 26	Distribution of stress for diaphragm (1200x1200 μ m)	20
Figure 27	Distribution of stress for diaphragm (1400x1400 μ m)	20
Figure 28	Distribution of stress for diaphragm (1600x1600 μ m)	20
Figure 29	Distribution of stress for diaphragm (1800x1800 μ m)	20
Figure 30	Distribution of stress for diaphragm (2000x2000 μ m)	22
Figure 31	Deformation in chip w.r.t. Pressure	22
Figure 32	Normal Stress in chip w.r.t. Pressure	22
Figure 33	Normal Stress in chip w.r.t. Pressure	22
Figure 34	Normal Stress in chip w.r.t. Pressure	23
Figure 35	Normal Strain in chip w.r.t. Pressure	23

List of Table

	TITLE	PAGE NO.
TABLE 1	Calculation of output voltage and sensitivity	18
TABLE 2	Diaphragm size 1200 X 1200 μm and chip size 4000 X 4000 μm	21

List of Abbreviation

MEMS	MicroElectroMechanical System
FEM	Finite Element Modeling
FEA	Finite Element Analysis
ΔP	Change In Pressure
V_{in}	Input Voltage
V_o	Output Voltage
S	Sensitivity.
μm	Micrometer
Kpa	Kilopascal
Mpa	Mega Pascal
P.Stress	Principal Stress
I_{off}	Initial Current
D	Bending Rigidity
E	Young Modulus
V	Poisson Ratio

Chapter 1

Introduction

In 21st century, the revolutionize change can be seen in MEMS technology has showing its potential to upgrade factories as well as the industrial products by combining silicon-based microelectronics With the help of ANSYS software, modelling and simulation of pressure sensor can be done, the stress generated is to be converted into voltage and the experimental set up is to be done on wheat stone bridge. For getting better result regarding improvement in sensitivity for the devices this result in research will be one step ahead. The MEMS technologies, in comparison with piezoresistive against capacitive MEMS offer greater levels of advantages. MEMS offer various benefits over the existing electromechanical type sensors. MEMS are generally of two types- piezoresistive and capacitive type. In this project piezoresistive sensors are been chose due to its properties which means cheap cost and high durability. MEMS devices have characteristics of small size ranging from a few micro-meters to millimetre, it joins mechanical and electrical components which is used for fabricates. The working principle of Piezoresistive MEMS type pressure Sensor is based on varies of resistance which result in change in voltage, the balanced body makes a difference When the Piezoresistive Sensor gets tilt/convert provides electric potential. Sensors Qualities improve in better density to shock with vibration, pressure along with dynamic changes. The requirement will not only to make a compact system but also to make a highly sensitive system which includes change in micro pressure. Here approach also combines the analysis of piezoresistive sensors with help of simulation and modelling in physical surroundings which depends on properties of parameterized behavioural body using software ANSYS R18.

1.1 Importance of the Research

The miniaturization of technology has been possible due to advances in MEMS (MicroElectroMechanical Systems) devices, specifically in micro sensors and actuators. Methods of improving sensing accuracy and reliability while decreasing sensor size and power consumption, therefore, are constantly being investigated. Many engineering applications, such as microsurgery, micro particals and micro robotics, are limited used by the various existing sensors and actuators. Recent studies on Peizoresistance have been conducted with numerous piezoresistive devices have been fabricated and when it tested to expand current understanding of the piezoresistive effect and how it can be utilized with more efficiently and in various applications.

Today, most of the literature is limited to the piezoresistive effect in compressive and tensile stresses and for thin films result in plane stress. In light of the advantages of compliant MEMS devices, the simple tension/compression model is insufficient. A more general Peizoresistance model which accurately accounts for bending and combined loads typical to compliant mechanisms is needed.

1.2 Thesis Contributions

In addition to presenting an extensive literature review of Peizoresistance, this thesis reports discusses on data gathered the piezoresistive effect of silicon's for tensile, stress based bending, and combined loads. The thesis includes the challenges involved in the design of an integral piezoresistive micro force and micro-sensor. With the data gathered, an outstanding model predicting force and displacement of current and voltage were created and for the prediction of a future temperature-dependent of silicon based piezoresistive model is presented.

1.3 Thesis Outline

This thesis begins with a comprehensive literature review of literature about the piezoresistive effect of silicon. A discussion taking up the strengths of piezoresistive sensors has been found in the literature in detail is provided and shown with a simple example with relation in tension. This thesis includes data with brief discussion of the piezoresistive effect of silicon & polysilicon's in tension and stress loads.

Here, the factors are conclude on the dimension, placement, and thickness of the element which outlines the necessarily considerations for the design of a piezoresistive pressure sensor and the basic need for an understanding of the Peizoresistance effect related bending and combined loads. The pressure sensor at max strength pressure determines the overall sensitivity. In the software ANSYS deformation is occurred with the help of simulation and stresses are considered at the different measurements for the varying pressure while having note about the safety with other reasonable points. This is what the reason how to make better, durable and long-life usage piezoresistive pressure sensor including the sensitivity of MEMS pressure sensors used in different application in our life. MEMS are devices in which mechanical, electronic parts and micro sensors along with the circuits which further fabricated on a micro piece of silicon. The letter S in the MEMS indicates the systems which shows that the major technology contributes the creation of new system.

The elements which are integrated on the silicon based chip using MEMS technology hence include micro sensors, mechanical and electrical structures, and microelectronics and actuators as shown in figure. Micro electro sensors are used to detect the changes in system's environment which are carried out by measuring various thermal, chemical, electromagnetic, mechanical, whereas these physical characteristics variables are processed by Microelectronics and then actuators acts according to the environment change.[2,4,5]

1.4 Layout

Here, our layout will consist of:

- I. Selection of Material.
- II. Design of Diaphragm

Here in our case we use three different cases as per our approach, the diaphragm is used for stress distribution, different parameters has been taken to get higher sensitivity for this there is need to use of different dimensions. This will be taken place to occur max sensitivity.

I. Pattern of diaphragm

In four arrangements, the design area of these diaphragms has been considered for accurate quick response different thickness, area with different dimension and pressure has been taken to get fast result.

I. Design the diaphragm and piezoresistivity in silicon has been used for Pressure- deflection expression

II. Modeling and Simulation

Deformation, stresses and pressure using various measurements has been calculated to find out sensing element while considering the various safety and crucial factors for the varying pressure.

I. Analysis with Comparison of Performance parameters

II. Stress and Deflection analysis.

Analyses are performed for various designs considering temperature compensation techniques, which are further extended as future work.

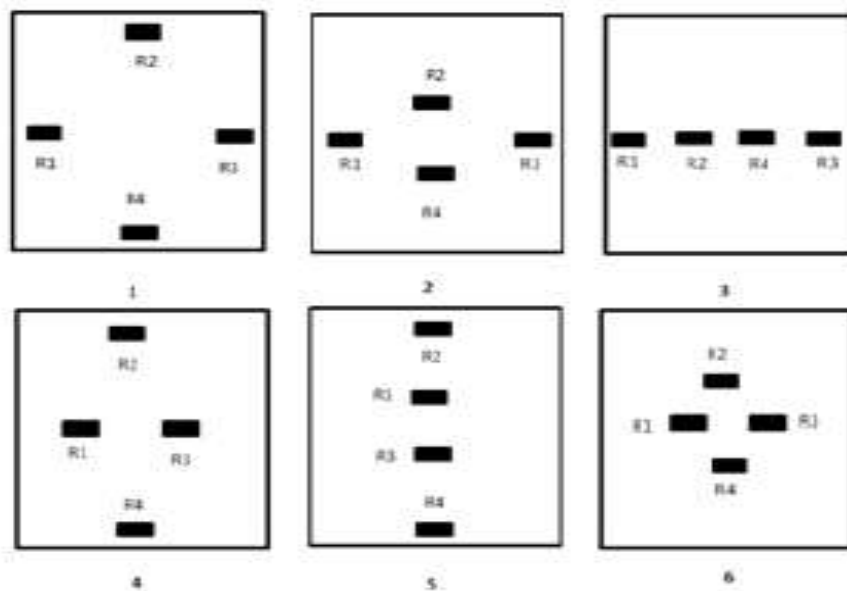

Figure 1 Arrangement of piezoresistors

Practically, plate has been considered as a relatively thin to get the satisfied ratio thickness, which is the thickness of the diaphragm to the lesser length in comparison to area is to be less than 1/20, the diaphragm is modelled in such a way as a plate store at the edges in MEMS type pressure sensor. (as shown in Fig 2). [5]

Using MEMS technology, the piezoresistors cannot be placed beyond the edges as said earlier of the diaphragm is considered as an actual diaphragm. A plate equation has been used to figure out the model the diaphragm since there are certain various limitations in such a project of a pressure sensor. Also, a stress in diaphragm is always over estimated as an assumption. [3,4,6]

The most important technical parameter of pressure sensors is sensitivity. The sensitivity calculated of most of the type of piezoresistive type pressure sensors, so the above equation is used to calculate sensitivity:

$$S = \frac{\Delta I}{I_{off} \times \Delta P}$$

Where ΔP is the change of pressure, change of current is described by ΔI , corresponding to pressure, initial current is shown as I_{off} .

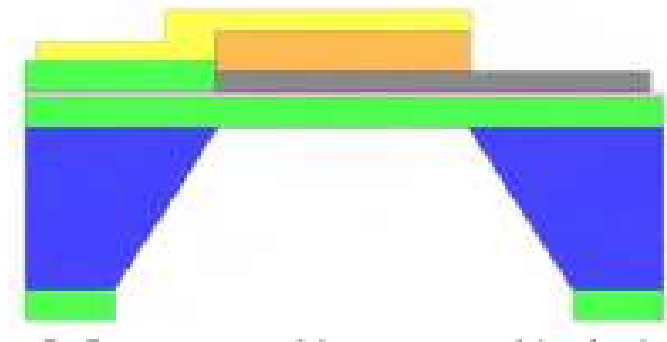

Figure 2 Structure of diaphragm

The silicon membrane with three shapes gives the deflection when the stress is applied. In this design, the area of piezoresistors has been considered at the diaphragm top. [7]

Chapter 2

Literature Review

2.1 Reviews

Pramanik et al. studied for a maximum pressure of 100 kPa. Using the burst pressure the diaphragm dimensions have been determined by considering with linearity factors. From the pramanik studies done a dimension of 1000 μm x 1000 μm with taken thickness of 17.2 μm has selected and also a smaller side length can be chosen for high sensor density. The placing the piezoresistors in highly sensitive locations is important for greater sensitivity. From the profile of the diaphragm the maximum limit for the length of the piezoresistors on which stress is occurred is determined as 180 μm and the random length of the piezoresistors has been taken by studying the change in the sensitivity on sensor and finding as a function of piezoresistors length.

Santosh Kumar et al. defines several important design considerations takes place to silicon based piezoresistive sensors which have been reviewed and analysed which may be pertaining. But its requires the use of FEM-based tools which needs a more ultra tech design analysis which is further used to perform a complex analysis which involves in the different types of factors like mechanical, electrical, and thermal factors. Here, longitudinal piezoresistive having coefficient has been increased to $-3,550 \times 10^{-11} \text{ Pa}^{-1}$ configuration with the dimensions taken in the paper for providing better sensitivity having pressure range of 0 to 1MPa. FEM tools as the anisotropic properties of silicon give great advantages. These have been required in obtaining a estimation of stress and strain. [1]

K.Y. Madhavi et al. Using the role played by important design parameters with the use of Finite Element Analysis (FEA) like the side length and thickness of the pressure sensing membrane in determining by providing sensitivity of the sensor has been studied for a maximum Sensitivity. The importance of placing the piezoresistors in various locations for higher sensitivity with different factors. From the stress dominate profile of the diaphragm the max limit occurs for the length of the piezoresistors.

Anh Vang Tran et al. works on FEM simulations which owes to membrane deflection and are under different pressures which further has been used to predict the stresses which are induced in the piezoresistors. Based on one of the curve-fitting method, further provide way for the critical design of the sensor with the given structure. The various equations give the relationship btw the variables dimension with in correspondence of mechanical performance has been determined.

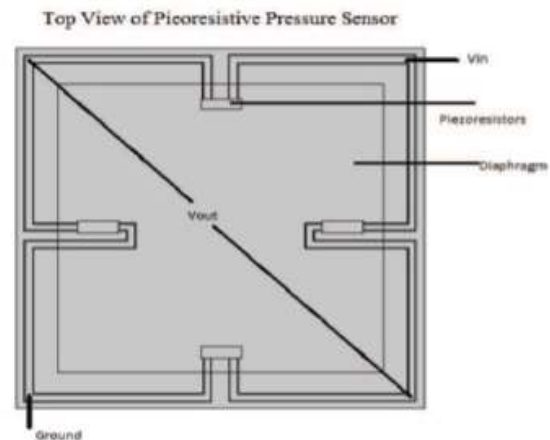

Fig. 3 Piezoresistive pressure sensor.

Shivam Sharma, Dr swet Chandan et.al has taught in detail about Piezoresistive pressure sensors which are widely used in various field such as automotive, industries, medical equipment etc. For high input from the sensing element, having good sensitivity in different surrounding conditions, the sensor should be in working condition. This paper works on the piezoresistive MEMS pressure sensor which shows higher sensitivity which is made of silicon material and related. The behaviour of the sensor depends upon various factors such as thickness, dimensional area, different properties of material etc. The piezoresistors of silicon material has been put in possible patterns and showed sensitivity for each plate.

Nallathambi et.al Its major involvement in novel large sensitivity and linear basically used for applications such as environmental, humidity with 0-1MPa piezoresistive type pressure sensor. The sensor showed sensitivity with having variable thickness, 19.5×10^{-12} for $5 \mu\text{m}$ thickness and i.e. rectangular and square membrane which is made through the FEM finite element tool. The two different structures i.e. rectangular and square based membrane consists of the same types of surface area. Finally, it has been seen that the fine deflection result has come from max stress related output and reactions from the rectangular membrane its can be seen the pressure range from $18.65 \mu\text{m}$ for $5 \mu\text{m}$ thickness and $6.8 \mu\text{m}$ for $7 \mu\text{m}$ 0.1MPa to 1MPa, thickness 84.3×10^{-12} for $3 \mu\text{m}$ thickness for two types of membrane has been taken. These studies result to improve the overall sensitivity.

Shou-En Zhu et.al has give the mechanism related to grapheme meander like shaped piezoresistive pressure sensor in detail under which poly-crystalline grapheme piezoresistive have been put in the max strain occurs in the diaphragm of silicon-nitride. The pressure related application of the diaphragm will occur with the V_o i.e. changes in output voltage.

Robert M. Panas et.al explains that the piezoresistors has been largely used under principle of pressure sensors design which causes influence on an outer stress due to their cheap cost, small size and having large range of dynamic. The fact which shows that there are different changes occurs in the material resistivity.

Shivam Sharma, Dr swet chandan et.al To find out the better sensitivity, the size and shape of piezoresistors are been considered with respect to the change in diaphragm size and change in chip size. After going through the shapes of piezoresistors, the result shows that the square shape piezoresistors are most sensitive with respect to the size of diaphragm and size of chip i.e. chip size $4000*4000\mu\text{m}$ and diaphragm size $1200*1200\mu\text{m}$. its shows that these position of piezoresistors are most desirable and also the stress induced on the diaphragm is more as compared to others and its showing good linearity. The result obtained on wheat stone bridge also signifies that the sensitivity occurs on reducing size of the area of piezoresistors.

Shwetha Meti et.al The proposed sensor diaphragm has been designed in such a technique i.e. n-type of Si and for the p-type shaped piezoresistive pressure sensor uses material (copper) as a arm connector which are placed on the diaphragm surface carry out operation at the diaphragm under high strain. to study the deflection the output design is analyzed the diaphragm and output voltage across the bridge. Piezoresistors like Meander shape are connected on Wheatstone bridge and are used different length which gets simulated, in order to find out the best fig and configuration for high sensitivity and linearity. Results show to find out the sensitivity that the $50\mu\text{m}$ length of piezoresistors has been found

Eswaran P, Malarvizhi S For the application use of capacitive pressure sensor which is highly in increase as per the upgradation in technology, hence it is highly suggested to view the path of technical upgradation. For Fabrication purposes MEMS based materials has been used, micro fabrication for polymer material diaphragm and silicon procedures has been considered. The

main focuses on the views of various types of capacitive pressure sensor based on different principle, capacitive sensitivity shows effect on plate's temperature of was shown and Selected result on capacitive sensitivity.

Lung-Tai Chen et.al The main area of study shows that pattern ultra-thick photo resists gets in a novel packaging pressure sensor is used. The photo resist materials has been used for sacrifice-replacement within corresponds of dam-ring which is used for the pressure sensing with EMC contamination to prevent the sensing-channel. For practical and theoretical investigation of the novel plastic packaging path of a piezoresistive sensor considered in using a pattern of ultra-thick photo type resist.

Vahid Mohammadi et.al In this paper, multilayer diaphragm acts as sensor or actuator. Diaphragm simulation is done on ANSYS. Multilayer diaphragm dynamics characteristics have been taken under consideration. Using simulation the multilayer PZT diaphragm parameters have been used in improvising pressure sensor performance with different pressure ranges. The thickness ratio of PZT layer to SiO₂ was describing in the paper to get the max deflects for the PZT diaphragm of multilayer thin-film.

Baoguo Han et.al The work done on type of cement based stress or strain sensors (PCSS) embedded piezoresistive which is used to monitor the compressive stress of cement-based material, hence finding out the piezoresistivity of concrete structures with carbon black & carbon fiber shows higher linearity. This justifies the use of cement-based material with carbon fiber and also carbon black for manufacturing embedded type PCSS. For performance PCSS is basically based on the piezoresistivity having range 0MPa to 8MPa. Results shows that PCSS is used to get a sensitivity- 1.45%/MPa, repeatability- 4.15%(4.06%), linearity- 4.17% (4.16%), and the relationship between its output and inputs.

Chapter 3

Parameter and Design

3.1 Introduction

Going through recent papers related to MEMS based piezoresistive pressure sensor, here the main principle of this paper is to find better sensitivity which will be found by comparing different shapes of piezoresistors i.e. rectangle, pentagon and hexagon with specific size. Through modeling and simulation, the required result can be obtained and these work on ANSYS workbench. The working of piezoresistors depends upon piezoresistive effect which occur due change in resistance. Mostly piezoresistors devices consist of semiconductor material and are used for the purpose for measurement of pressure. This technology has also been utilized for test apps, safety devices, and numerous applications in the military, medical and automotive sectors. In this paper the main material will be silicon which is doped into p-type semiconductors which gives better sensitivity in terms of n-type semiconductor. The system works on wheat stone bridge where the piezoresistors are arranged n the diaphragm in that form to get higher output. Here, for pointing out piezoresistors for construction means the sensors are cheap cost and long life. The response time compare with linear output pressure is typically less than one msec. Basic qualities of these types of sensors are free from vibration, having good shock resistance. [8] They are used for a wide range of change in pressure from 21 KPa to 150 MPa. When the stress is generated on piezoresistors then the diaphragm will undergo change in resistance. These sensors are operated at higher temperatures under different environment which are more suitable. Piezoresistive Sensor working principle is basically based on change of resistance. The requirement will not only to make a compact system but also to make a highly sensitive system which includes change in micro pressure. When the change is applied the electric potential is occurred to the Piezoresistive Sensor, and then the balanced bodies create a difference. The mass- spring system is designed in such a way so the force exerted by the spring exerts equals acceleration which are used to measure by the strain gauge is directly proportional to the force required to accelerate the mass, and the displacement of the mass.

3.2 Diaphragm Details

Diaphragm pattern: The diaphragm here consists of five different patterns style mainly change in size.

First the diaphragm size will be 1200*1200

Second will be 1400*1400

Third will be 1600*1600

Fourth will be 1800*1800

Fifth will be 2000*2000.

3.3.1 Design of Diaphragm

For maximum sensitivity the stress distribution in the diaphragm takes place, so we take difference in the dimensions [3,4]. For different cases i.e. three, take parameters in thought of getting large sensitivity]. In Ist case, pressure varies taken place from (10-160) KPa with the dimension taken as (1200 μm *1200 μm *15 μm). In IInd case, the pressure taken 120kPa where dimension varies from (700-1200) μm having thickness constant of 15 μm while in IIIrd case, we assume dimension (1200 μm *1200 μm) where thickness ranges from (5-15) μm . pressure at 120kPa. [8,9]

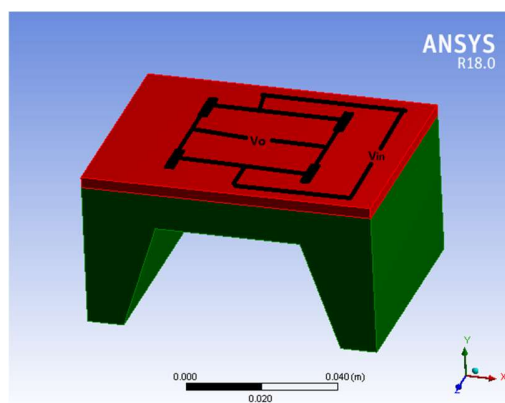

Figure 4 piezoresistors placed on diaphragm

1st case

Dimension ($1200 \mu\text{m} * 1200 \mu\text{m} * 15 \mu\text{m}$) has been constant while pressure ranges from (10-160)KPa.

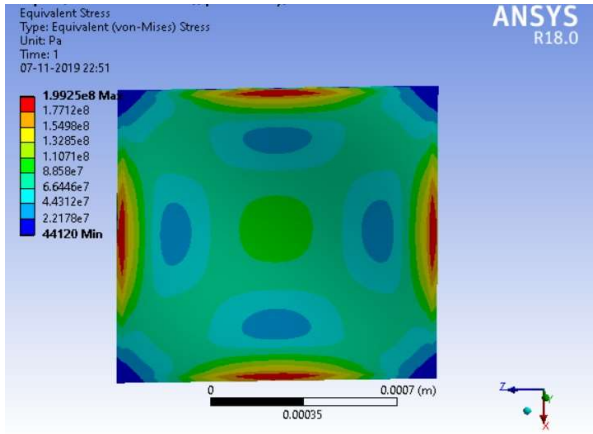

Figure5 Max stress

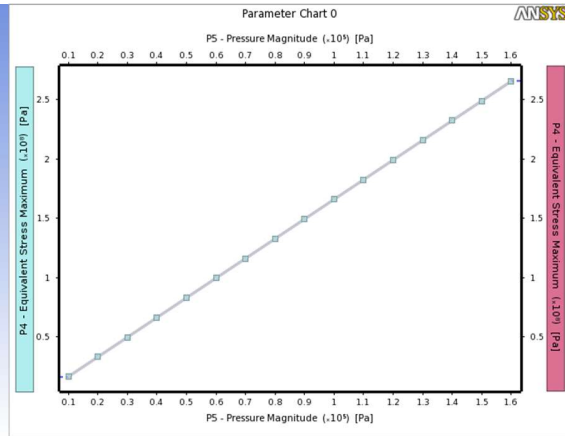

Figure 6 Pressure Variation vs M. Stress

The pressure changes where dimensional and thickness has been fixed. In this deformation, result shows the areas where the stress is max and minimum. This shows the equivalent Stress by using FEM with software ANSYS. [5].

To analyze the data Finite element method FEM is used which give result as the graph. By using FEA, result is obtained.

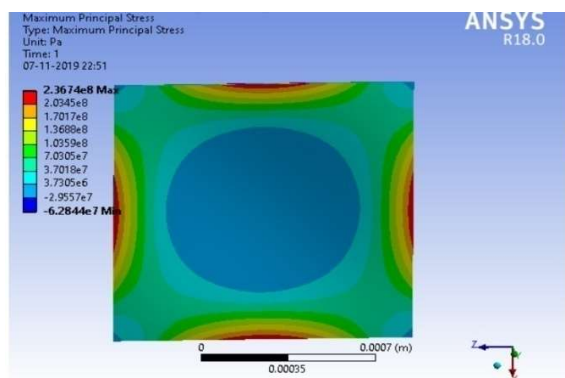

Figure7 Max Principal stress

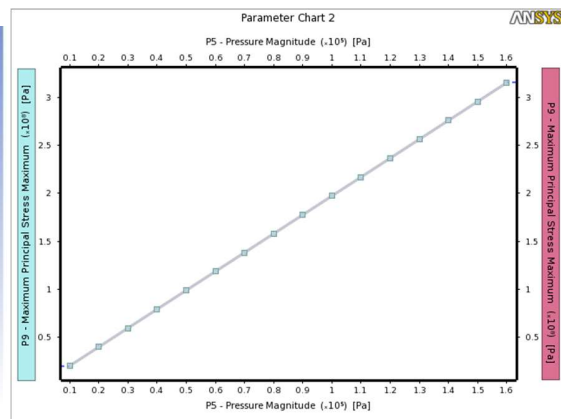

Figure 8 Pressure Variation vs P. Stress

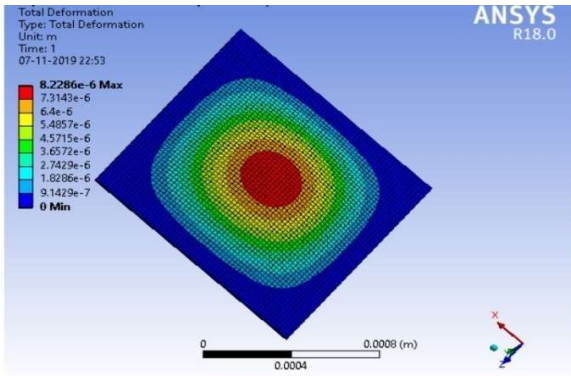

Figure 9 Total deformation due to stress

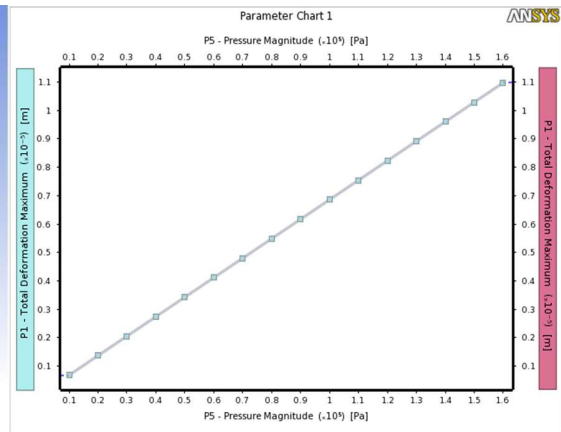

Figure10 Pressure Variation vs Total deformation

In this figure10, the grape shows the variation between pressure and deformation occurs on the diaphragm.

*Constant pressure at 120 KPa along with diaphragm dimension as 1200*1200*15 μm

Piezoresistivity principle is used in designing sensors such as micro pressure sensor etc which is available at cheap cost, micro size, and high dynamic range [16]. A influence of an external strain occurs due to change in the resistivity [5,6,8].

2nd case

Figure describing fixed pressure range of 120KPa and constant thickness 15 μm .

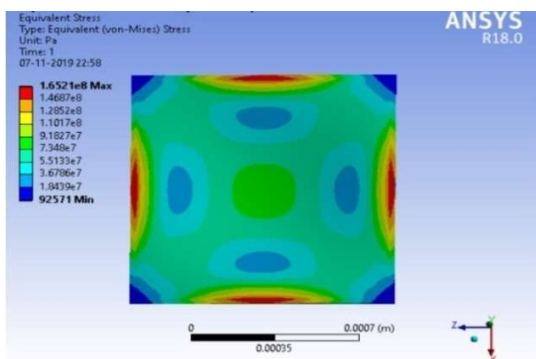

Figure11 Figure showing Equivalent stress

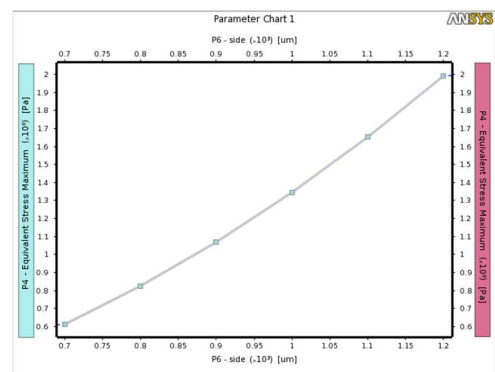

Figure12 M. Stress VS Pressure Variation

Again, the data given shows the stress is resulted with max & mini stress [5].

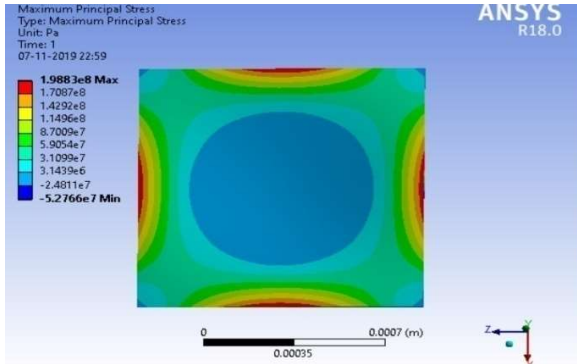

Figure13 Max principal stress

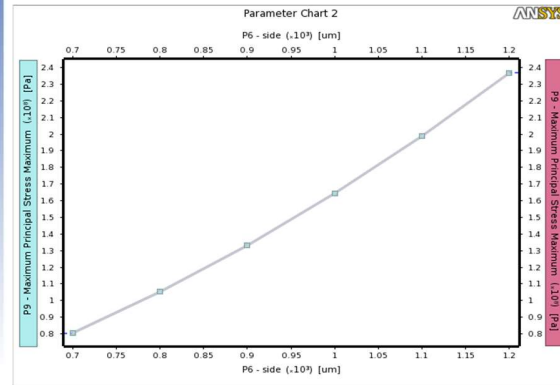

Figure14 P. Stress VS Pressure Variation

For 2nd case max stress is resulted in the above figure

The data for thickness in relation with linear pressure have been constant i.e. 15 μm & 120KPa and with dimension 2*1100 μm. [5]

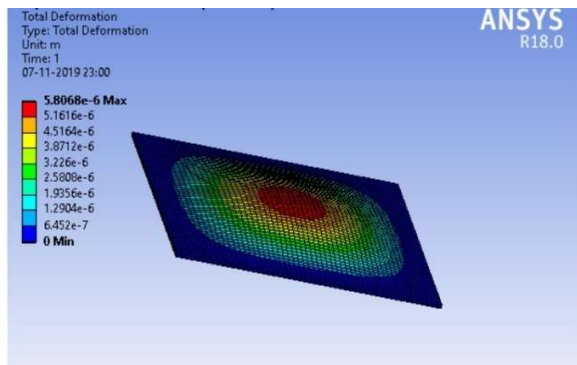

Figure15 Figure showing Total deform

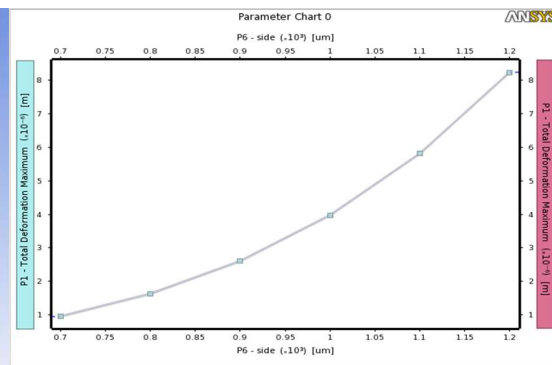

Figure16 Total deformation VS. Pressure Variation

3rd case

The area taken as constant at (1200 μm * 1200 μm), with pressure constant at 120KPa while thickness varies from (5-15) μm [5].

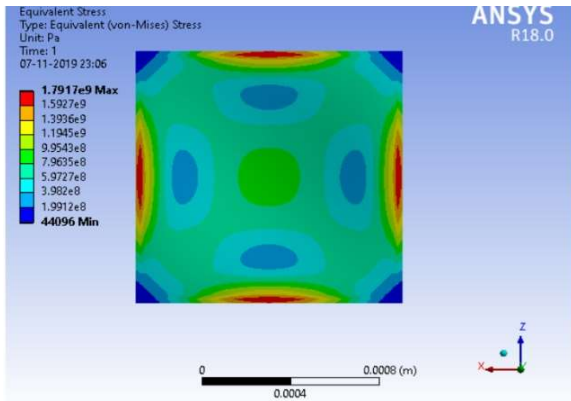

Figure17 Max stress

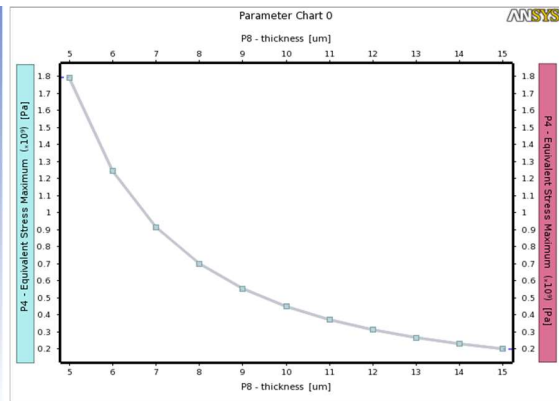

Figure18 M.Stress VS Pressure Variation

According to showed data, the deformation occurred due to stress at the mid where at the corners less stress can be seen. [10,11,]

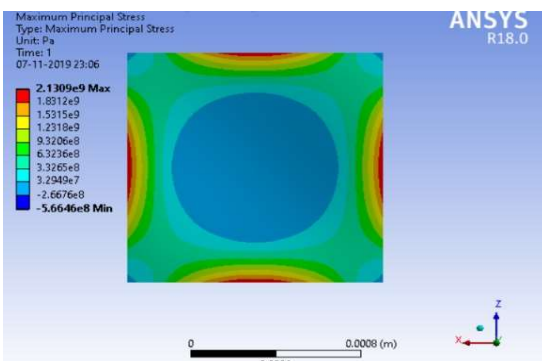

Figure19 Max Principal stress

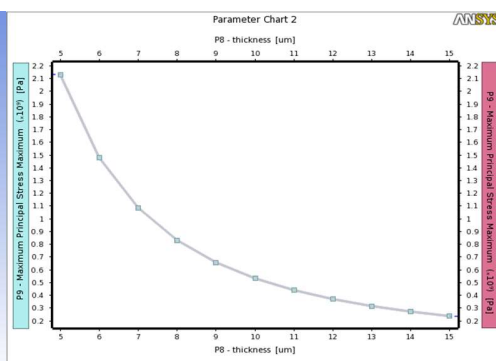

Figure.20 P. Stress VS Pressure

Constant pressure at 120KPa, dimension at 1200 μm * 1200 μm and thickness taken 6 μm

The above graph shows the thickness for deformation ranges from (5-15) μm [12,13]

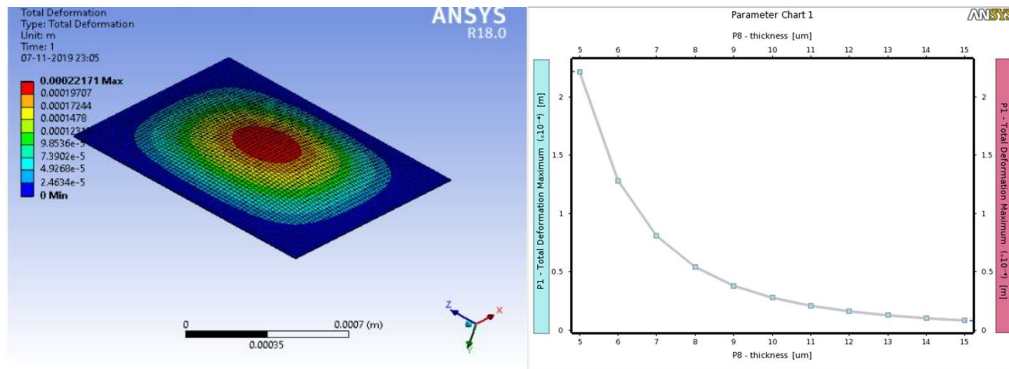

Figure21 Figure showing Total deformation Figure22 Pressure Variation vs Total deformation

3.3.2 Pattern of Diaphragm

The design consideration of these diaphragms to get higher sensitivity, fast and accurate result has been taken in four arrangements, considering of variable thickness, stress and pressure applied.

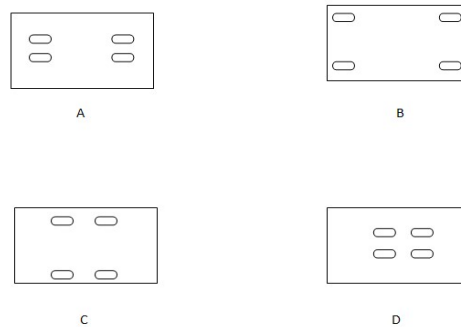

Figure 23 Different arrangement of piezoresistors of diaphragm pattern

By given formula we will find the variation in resistance:

$$\pi_1 \sigma_1 + \pi_t \sigma_t = \frac{\Delta R}{R} \quad [9]$$

Here,

π_t = transverse and π_1 = longitudinal piezoresistive coefficients.

$$\sigma_t = \nu \sigma_1$$

For that the terms, $\pi_1 = 71.8 \times 10^{-11} / \text{Pa}$, $\pi_t = 66.3 \times 10^{-11} / \text{Pa}$ respectively. The π value for n-type semiconductors has been taken from graph data which is lesser compared to P-type of (silicon) material. [1,6]

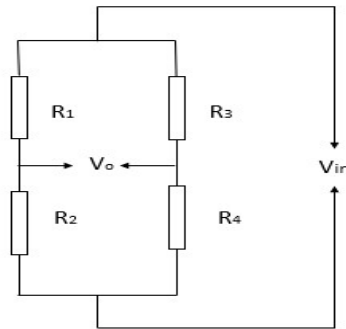

Figure24 Arrangement of Piezoresistors in Wheatstone bridge

The piezoresistors arrangements are done on Wheatstone bridge is designed above. The piezoresistors values as $1\text{k}\Omega$ while input voltage V_{in} 11V. The piezoresistors orientation is taken in such a way so the final output should be more precise. Sensitivity formula is used where change of applied pressure is Δp , V_o is output and V_{in} is input voltage.

$$S = \frac{V_o}{V_{in}} \times \frac{1}{\Delta p} \quad [10]$$

Here the following tables shows the calculation done to find out output voltage and sensitivity.

Table1: calculation of output voltage and sensitivity

(ΔP at 120kPa)	(Sensitivity)	(Output Voltage)
I st case	9.15	1.098
II nd case	7.63	0.91
III rd case	8.36	0.98

3.3 Piezoresistors Details

Here, different shapes and size are been distinguished which have differentiated further in this.

3.3.1 Piezoresistors Shape

i. Here, three different shapes of 4 piezoresistors are taken:

Square shaped piezoresistors

Pentagonal piezoresistors

Hexagonal piezoresistors

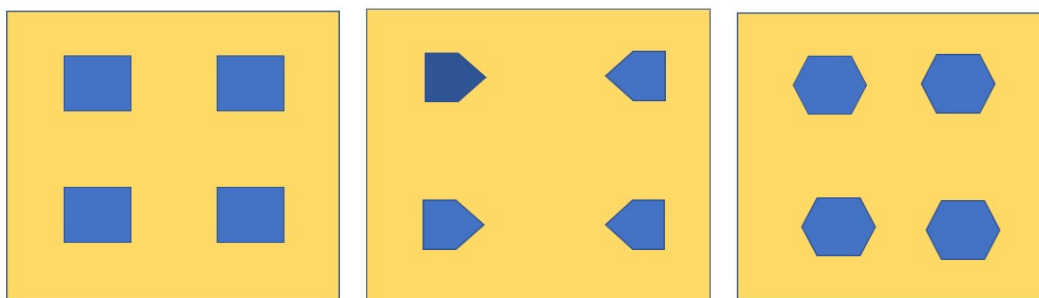

Figure 25 a) Square shaped piezoresistors. b) Pentagon shaped piezoresistors. c)Hexagon shaped piezoresistors.

3.3.2 Size of Piezoresistors:

Considering Resistors width = 15 μm , length of the piezoresistors = 300 μm and thickness = 1 μm .

For getting better result we compare different sizes of piezoresistors in terms of length and variable width as given below:

Length of piezoresistors 50 μm and thickness 5,10,15,20 μm

Length of piezoresistors 60 μm and thickness 5,10,15,20 μm

Length of piezoresistors 70 μm and thickness 5,10,15,20 μm

The whole parameters considered for the design is carried out by the change in pressure from 0 to 1.1 bar pressure. As it is clear one bar is equal to 100 KPa, so according to the result, the idea of altitude will be taken from the graph of pressure measured and altitude. The whole modelling and simulation is done on “static structural” ANSYS R18.0. For the best result in terms of sensitivity and linearity all the design parameters will be figured out and the most appropriate and best will be taken. Here, in the result section different design parameters are compared and the highly sensitive models design. [4, 7, 11]

3.4 Modelling of Piezoresistors

The software at which these simulations occur is ANSYS R18.0. According to the data, the stress occurs the most at 1200*1200 μm . the red area showing the max stress and the blue shows the minimum stress.

The deformation in chip occurs from 0 to 6.00e-02 with pressure ranges from 0.1 to 1.1 bar. The second graph showing variation in normal stress i.e. 0 to 4.00e+00 with pressure from 0.1 to 1.1. The third graph showing the variation in normal strain i.e. 0.00e+00 to 5.00e-04 with pressure range 0.1 to 1.1. On Different parameters the simulation is done and the stress distribution is shown below:[10]

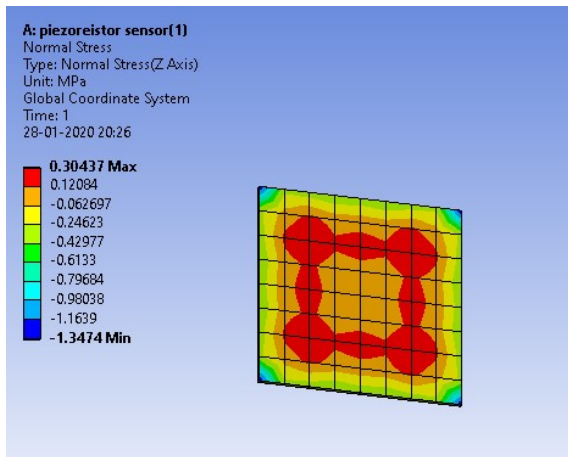

Figure 26 Distribution for Stress of diaphragm dimension (1200x1200µm)

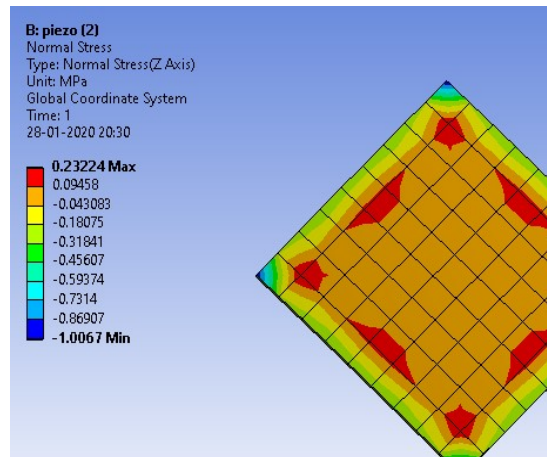

Figure 17 Distribution for Stress of diaphragm dimension (1400x1400µm)

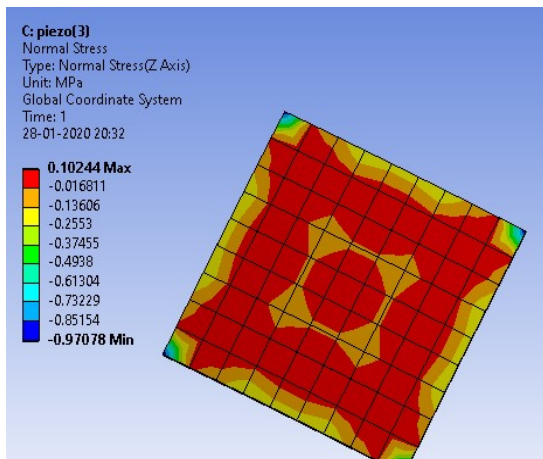

Figure 28 Distribution for Stress of diaphragm dimension (1600x1600 µm)

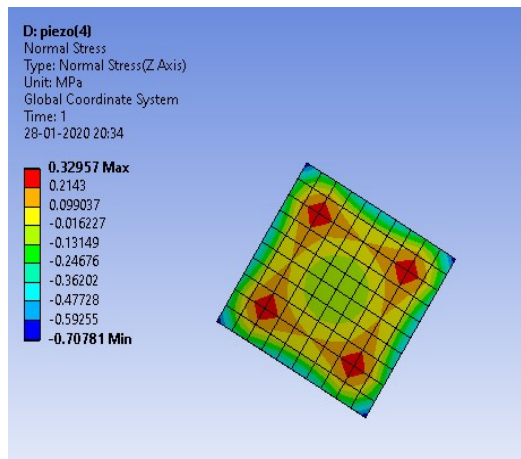

Figure 29 Distribution for Stress of diaphragm dimension (1800x1800 µm)

Table showing the stress distribution according to Diaphragm size and chip size. On doing simulation in ANSYS 18.0 the results show that the behavior of the sensor is better at the dimension $1200 \times 1200 \mu\text{m}$ and 5mm thickness of the diaphragm. The observation table and the comparison chart are shown below:

Table 2: Diaphragm size 1200 X 1200 μm and chip size 4000 X 4000 μm

Pressure In bar	Max. total deformation in mm	Max. normal stress in MPa	Max. normal strain in mm/mm
0.1	2.71E-03	3.04E-01	2.46E-05
0.2	5.42E-03	6.09E-01	4.92E-05
0.3	8.13E-03	9.13E-01	7.38E-05
0.4	1.08E-02	1.22	9.83E-05
0.5	1.35E-02	1.52	1.23E-04
0.6	1.63E-02	1.83	1.48E-04
0.7	1.90E-02	2.13	1.72E-04
0.8	2.17E-02	2.43	1.97E-04
0.9	2.44E-02	2.74	2.21E-04
1	2.71E-02	3.04	2.46E-04
1.1	2.98E-02	3.35	2.70E-04

The below graph comparing three different properties, the first one showing the graph between deformation vs change in pressure, the second one represents Normal stress vs change in pressure and the third one represents Normal strain vs change in pressure.

3.5 Finite Element Analysis

The model of finite element allow us to find out dynamics characteristics as well as static structural behaviors of the diaphragm as its give the variation width with the square diaphragm which having many layers related to frequency and to model a micro thin film diaphragm which is used in applications based on the sensors and actuators.

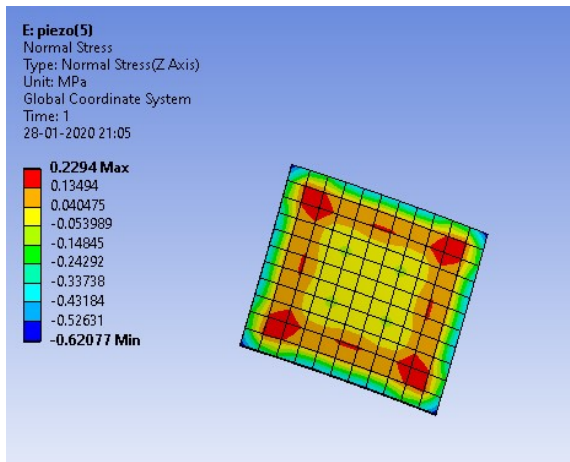

Figure 30 Distribution of stress for diaphragm dimension (2000x2000 μm)

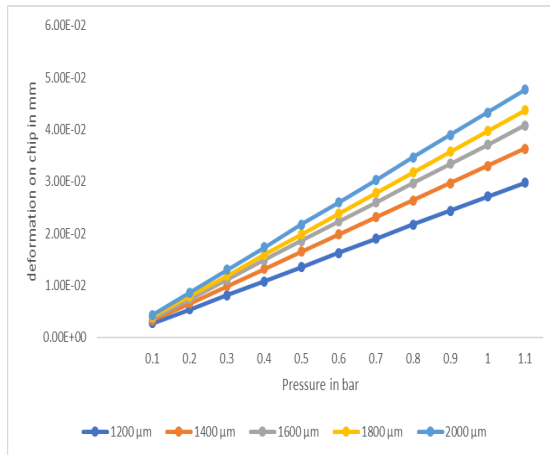

Figure 31 Deformation in chip w.r.t. Pressure

Simulation results and graphs are showing that the stress distribution is relevant throughout the surface for the chip having dimension of $1200 \times 1200 \mu\text{m}$ over which the piezoresistors having square shape of side length $50 \mu\text{m}$ and thickness $20 \mu\text{m}$ will give the best sensitivity than others.

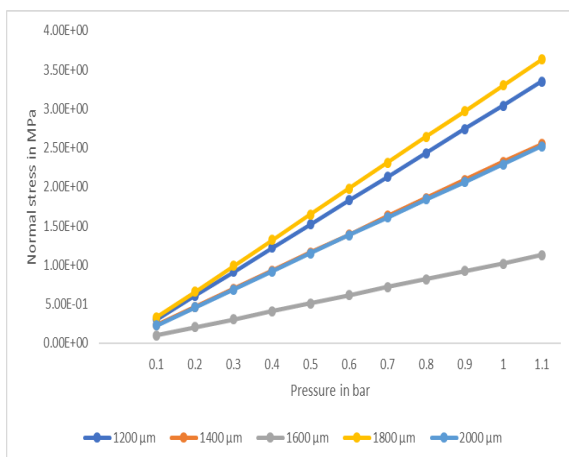

Figure 32 Normal Stress in chip w.r.t. Pressure

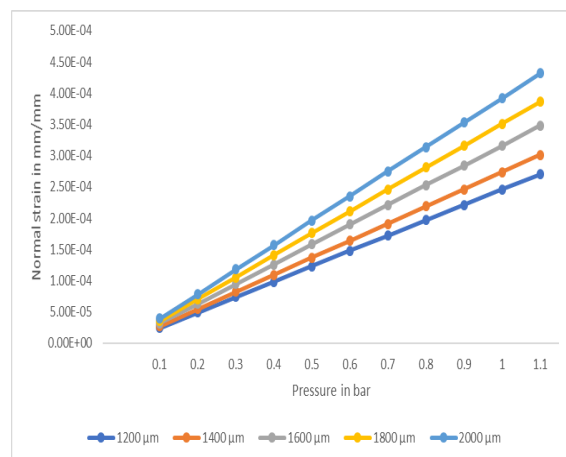

Figure 33 Normal Strain in chip w.r.t. Pressure

Since the piezo resistors are placed at different position respective to increase the sensitivity. The deformation and pressure calculated which is done on ANSYS simulation software with the use of sensing element for various varying pressure shows strength while keeping the important factors in mind for safety. The report says that, the best sensitivity i.e. 9.15 is found also it is clear that sensing element having side length and thickness of 1200, 15 μm . The different micro diaphragm carrying fewer dimensions has been placed into the positions from where they can get high response.

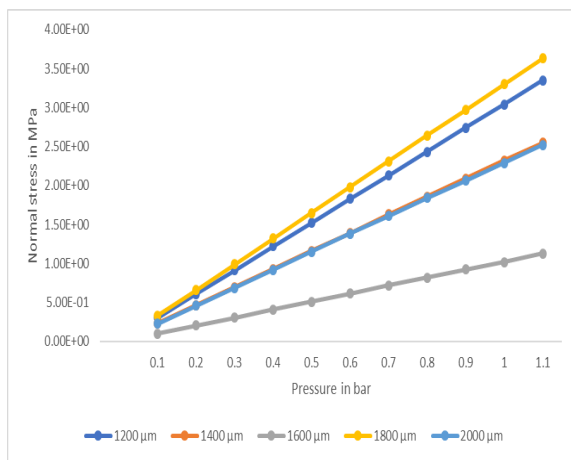

Figure 34 Normal Stress in chip w.r.t. Pressure

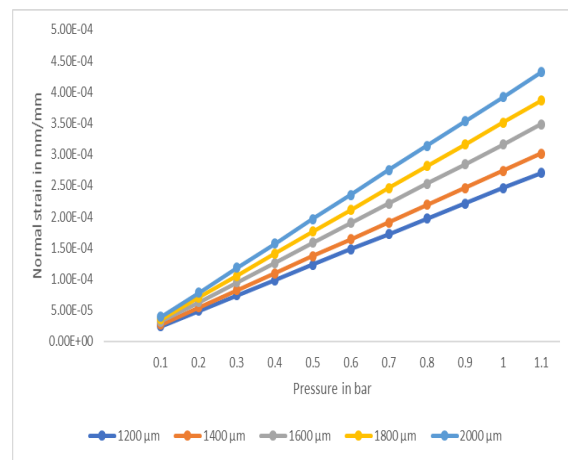

Figure 35 Normal Strain in chip w.r.t. Pressure

3.6 Mathematical Expression

Formula for finding out the change in Peizoresistance:

$$\frac{\Delta R}{R} = \pi_1 \sigma_1 + \pi_t \sigma_t$$

Where $\sigma_1 = P \frac{a^2}{h^2}$ and $\sigma_t = \nu \sigma_1$ are longitudinal and transverse stresses.

Transverse and longitudinal piezoresistive coefficients i.e. $\pi_t = 17.09 \times 10^{-11} \text{ Pa}^{-1}$ and $\pi_l = 32.6 \times 10^{-11} \text{ Pa}^{-1}$.

In diaphragm, the arrangement done on piezoresistors in such a manner as compared to formation in Wheatstone bridge and the voltage output is calculated by the following expression:

$$\frac{V_o}{V_{in}} = \frac{1}{4R_o} (\Delta R_1 - \Delta R_2 + \Delta R_3 - \Delta R_4)$$

The displacement quantity which is measured is carried out by this formula:

$$X = \frac{0.00126PL^2}{D}$$

Where P=Pressure occur on the diaphragm,

L= Diaphragm length,

D=Bending rigidity

For describing bending rigidity, the formula is given below:

$$D = \frac{Et^2}{(1-\nu^2)12} \quad [3]$$

Where, ν =Poisson ratio

E=Young modulus

t= Thickness

The increases length of the piezoresistors is proportional to increase piezoresistive related material resistance. This is something that make the system more reliable.

To find sensitivity, the following equation is given below:

$$S = \frac{V_o}{V_{in}} \times \frac{1}{\Delta P}$$

Where V_o = Output voltage

V_{in} = Input voltage

ΔP = Change in pressure

S= Sensitivity.

Offset voltage is the term defined as the pressure sensor output voltage as when the amount of pressure applied is zero.

The resistors are placed in such a way like R1 and R3 placed perpendicular to the edge of the common diaphragm which on increase in resistance occurred due to the longitudinal and tensile stresses whereas R2 and R4 are been placed parallel to the edge of the diaphragm having experience with an equal decrease in resistance.

In aspect, preliminary efforts are taken to characterize Piezoresistance which is required for bending and combined Loads, linear piezoresistive types models deploys to predict the piezoresistive Effect which is used for bending and combined loads. The piezoresistors length also plays a major role for determining. This is caused due to two possibilities; the first is due to less amount of residual stress is left, and the second is four piezoresistive pressure sensor variable characteristics. Hence sensor sensitivity is defined for varying lengths of the piezoresistors which are arranged in pattern 1 determined for a pressure of 100 KPa. Using the this pressure technique the diaphragm dimensions have been determined by considering linearity factors.

Chapter 4

Results and Discussion

The factors include sensors in their way to find out the sensitivity at the strength of max pressure. Calculated done at various measurements for finding the result use of software, also to find outstresses, deformation and linearity of the sensing element for varying pressure.

4.1 Simulation Result

The conclusion which comes out from the analysis is that the various element with dimensions and thickness of (1200,15) μm of the diaphragm provides the best sensitivity, which in future used in different environment. To find out the good sensitivity, the sizes with change in shape of piezoresistors have been considered to figure out. Different elements has been taken for fast results in terms of sensitivity are carrying small areas have been used for the better linearity. Firstly, the piezoresistors in a plate is advised not to be placed at the different edges with respect to the change in diaphragm size and chip size showed using MicroElectroMechanical system. The overall work done is taken consideration for the accurate measurement and finding the linearity of the model. The piezo resistors is been placed in specified locations to enhance the system sensitivity. The MEMS based pressure sensor diaphragm is modelled as a plate stacked at the edges. A piezoresistive plate is considered to be very small compared to the thickness ratio, which is the diaphragm dimension to the lesser length is lesser than. Plate equations carry out to make the pressure sensors diaphragm. Plus, the deflection on the diaphragm should not be taken over estimated. Piezoresistive pressure Sensor is singularly based on resistance change which further shows the change in voltage. Whenever the tilt of the plate of Piezoresistive Sensor, then there will be a same mass which substituent's among change in electric potential the whole simulation work done on ANSYS 18.0 workbench at static structural.

Chapter 5

Conclusions and Recommendations

5.1 Conclusions

The simulation software ANSYS is used to carry out the whole operation which is further calculated at different measurements includes deflection and stresses of the sensing body. The conclusion that occurred for providing the best sensitivity i.e. 9.15 using the sensing element which are consists of side length and thickness i.e. (1200-15) μm . After going through the shapes of piezoresistors, the result shows that the square shape piezoresistors are most sensitive with respect to the size of diaphragm and size of chip i.e. chip size 4000*4000 μm and diaphragm size 1200*1200 μm . its shows that these position of piezoresistors are most desirable and also the stress induced on the diaphragm is more as compared to others and its showing good linearity. Different sense element took fewer dimensions which is calculated further for getting the result in means of linearity. To find out the better sensitivity, the size and shape of piezoresistors are been considered with respect to the change in diaphragm size and change in chip size. After going through the shapes of piezoresistors, the result shows that the square shape piezoresistors are most sensitive with respect to the size of diaphragm and size of chip i.e. chip size 4000*4000 μm and diaphragm size 1200*1200 μm . its shows that these position of piezoresistors are most desirable and also the stress induced on the diaphragm is more as compared to others and its showing good linearity. The result obtained on wheat stone bridge also signifies that the sensitivity occurs on reducing size of the area of piezoresistors for better sensitivity. During simulation process, the data which is taken as the material of the diaphragm is taken as silicon di oxide, young's modulus result as 73 GPa, thermal expansion coefficient value as $0.55 * 10^{-6}$ and Poisson's ratio is 0.17.

5.2 Recommendations

The crystalline structure have a silicon content of about 99.9%, in which MEMS devices provide excellent mechanical properties which gives no fatigue having properties as pure crystalline.. It is possible for cheap cost and high-output sensitive MicroElectroMechanical devices having different batch processing technology. These types of highly orientated devices are used to test and upgrade with the help of software systems that are available for design and simulation.

Reference

- [1]. Jaspreet Singh, K. Rajanna et.al, "Effect of Process Deviations on Performance of Piezoresistive Pressure Sensors," IEEE Transactions on Semiconductor Manufacturing, 2014, vol.27, no.3, pp.410-41
- [2]. Swet Chandan, Shivam Sharma and Yashwardhan Sahi, "Design of Piezoresistive Sensor using FEA in ANSYS," ICMET-2019 International Conference on Mechanical and Energy Technologies paper id-207.
- [3]. A. Nallathambi et.al, "Design and Analysis of MEMS based Piezoresistive Pressure sensor for Sensitivity Enhancement" ELSEVIER 2016.
- [4]. J. Mandle, et.al, "A new micro-machined silicon high accuracy pressure sensor": [https://doi.org/10.1016/0924-4247\(94\)00875-I](https://doi.org/10.1016/0924-4247(94)00875-I) 129-132, 1995.
- [5]. V. Mohammadi, "Design modeling and optimization of a piezoelectric pressure sensor based on thin film PZT diaphragm contain of Nanocrystalline powders" in 6th international symposium on mechatronics and its applications, ResearchGate, April, 2009.
- [6]. Y. Kanda, "A graphical representation of the piezoresistance coefficients in silicon", IEEE transaction on electron devices 29(1) 64-70, 1985.
- [7]. T. Pravinraj, et.al, "Piezoresistor size effect on sensitivity of SOI piezoresistive pressure sensor" in Communications in Computer and Information Science: Preface, ResearchGate, 2011.
- [8]. KJ Suja, R. Komaragiri, "Computer aided modeling for a miniature silicon-on-insulator MEMS piezoresistive pressure sensor", Photonic Sensors volume 5, 2015, pp. 202–210.
- [9]. K Y Madhavi et.al, "Design of piezoresistive micro pressure sensor using finite element analysis" in International journal of computer application volume 70-No.3, May, 2013
- [10]. ANSYS guide release 18.0 ANSYS Inc. <https://www.ansys.com>
- [11]. W G Pfann, R N Thurston, "Semiconducting stress transducers utilizing the transverse and shear piezoresistance effect", Journal of applied physics Vol.32 No.10, 2008
- [12]. Bae, B.; Flachsbarth, B.R.; Park, K.; Shannon, M.A. Design optimization of a piezoresistive pressure sensor considering the output signal-to-noise ratio. J. Micromech. Microeng. 2004, 14, 1597–1607. [CrossRef]
- [13]. Mahmoodi, M.; Ghazanfari, L. Physics and Technology of Silicon Carbide Devices; GmbH: Weinheim, Germany, 2012; pp. 349–378.