

Advanced Maths for Chemists

Chemistry Maths 3

J. E. Parker

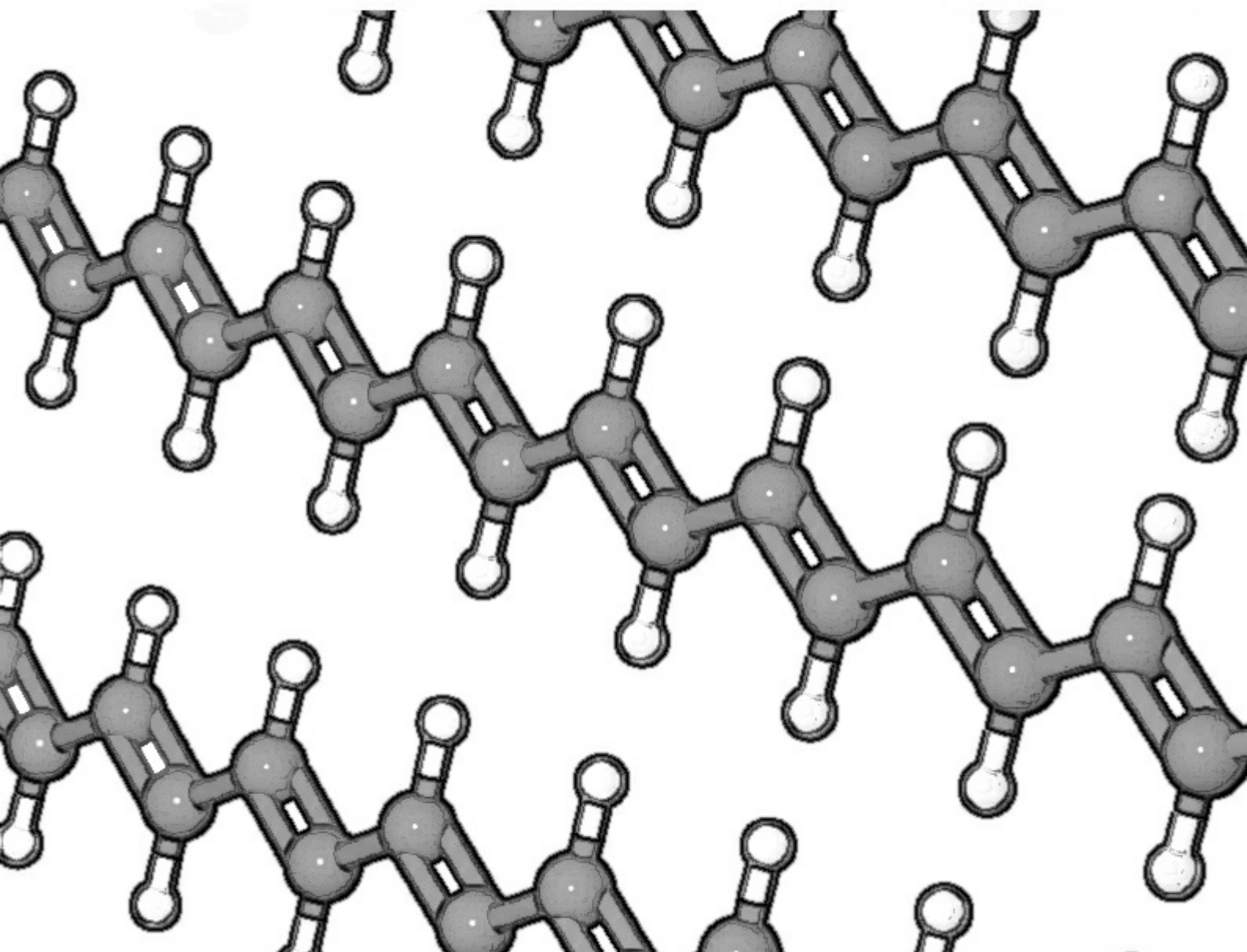

J.E. Parker

Advanced Maths for Chemists:

Chemistry Maths 3

Advanced Maths for Chemists: Chemistry Maths 3

1st edition

© 2015 J.E. Parker & bookboon.com

ISBN 978-87-403-0372-8

Contents

	Acknowledgements	7
	Introduction	8
1.	Week 1: Chemical Data: Linear Least Squares Curve Fitting	10
1.1	Least Squares Curve Fitting	10
1.2	Week 1 Tutorial Questions	16
1.3	Week 1 Tutorial Solutions	23
2	Week 2: Chemical Data: Non-Linear Least Squares Curve Fitting	33
2.1	Nonlinear Least Squares (NLLSQ) Curve Fitting	33
2.2	Week 2 Tutorial Questions	38
2.3	Week 2 Tutorial Solutions	43

I joined MITAS because
I wanted **real responsibility**

The Graduate Programme
for Engineers and Geoscientists
www.discovermitas.com



Month 16

I was a construction
supervisor in
the North Sea
advising and
helping foremen
solve problems

Real work
International opportunities
Three work placements



 **MAERSK**

3	Week 3: Chemistry and Complex Numbers	52
3.1	Why use Imaginary Numbers and Complex Numbers?	52
3.2	Week 3 Tutorial Questions	64
3.3	Week 3 Tutorial Solutions	66
4	Week 4: Chemistry and Complex Numbers	69
4.1	Week 4 Tutorial Questions	69
4.2	Week 4 Tutorial Solutions	73
5	Week 5: Chemistry and Matrices	78
5.1	Why use Matrices with Chemistry?	78
5.2	Week 5 Tutorial Questions	80
5.3	Week 5 Tutorial Solutions	89
6	Week 6: Chemistry, Matrices and Hückel Theory	105
6.1	Week 6 Tutorial Questions	110
6.2	Week 6 Tutorial Solutions	112



www.job.oticon.dk

oticon
PEOPLE FIRST



7	Week 7: Chemistry and Vectors	127
7.1	Week 7 Tutorial Questions	128
7.2	Week 7 Tutorial Solutions	131
8	Week 8: Chemistry and Vectors	135
8.1	Week 8 Tutorial Questions	135
8.2	Week 8 Tutorial Solutions	138
9	References	142
10	List of Formulae	143



Schlumberger

WHY WAIT FOR PROGRESS?

DARE TO DISCOVER

Discovery means many different things at Schlumberger. But it's the spirit that unites every single one of us. It doesn't matter whether they join our business, engineering or technology teams, our trainees push boundaries, break new ground and deliver the exceptional. If that excites you, then we want to hear from you.

careers.slb.com/recentgraduates

Acknowledgements

I was pleased to respond to Ventus Publishing to write a textbook (which is split into 3 more manageable books, “Introductory Maths for Chemists: Chemistry Maths 1”, “Intermediate Maths for Chemists: Chemistry Maths 2”, and “Advanced Maths for Chemists: Chemistry Maths 3” which should be studied in sequence) that would help Chemistry students survive, and even enjoy, the Maths required for a Chemistry degree. I developed and presented tutorials on Maths to our first year Chemistry students over several years at the Chemistry Department, Heriot-Watt University, Edinburgh, Scotland. These tutorials have formed the basis for this workbook. I would like to thank the staff of Heriot-Watt University Chemistry Department for their help; and thank the students who for many years “suffered” these tutorials, I hope they helped them with their Chemistry degrees and later careers. Most of all I would like to thank my wife Jennifer for her encouragement and help over many years.

I shall be delighted to hear from readers who have comments and suggestions to make, please email me. So that I can respond in the most helpful manner I will need your full name, your University, the name of your degree and which level (year) of the degree you are studying. I hope you find this workbook helpful and I wish you good luck with your studies.

Dr John Parker, BSc, PhD, CChem, FRSC
Honorary Senior Lecturer
Chemistry Department
Heriot-Watt University
Edinburgh

January 2013

J.E.Parker@hw.ac.uk

<http://johnericparker.wordpress.com/>

Introduction

The three books (Parker 2011 and Parker 2012), Introductory, Intermediate and Advanced Maths for Chemists are tutorial workbooks intended for first year undergraduates taking a degree in *Chemistry* or a Chemistry based subject such as *Chemical Engineering*, *Chemical Physics*, *Molecular Biology*, *Biochemistry* or *Biology*. The texts may also be very useful for final year school or college students prior to them starting an undergraduate degree and their Chemistry teachers. The books are split into three in order to reduce file size and make handling on a laptop or tablet computer easier. Introductory Maths for Chemists roughly covers the first 8 weeks of semester 1; Intermediate Maths for Chemists the remainder of semester 1 and the beginning of semester 2; and Advanced Maths for Chemists the rest of semester 2. They each have chapter heading such as Week 1, Week 2 and so on. This is *purely* to help you self-pace your work on a weekly basis although I realize that the week numbers in Intermediate and Advanced Maths for Chemists will not correspond to your semester week numbers.

This workbook is *not* a textbook! Use your Chemistry and Maths textbooks to find out the details about the areas covered. People will not really understand any subject, including Maths, until they can use it in a flexible way. *Tutorials* are a way of allowing you to practice your skills, in this case the Maths required by Chemists, so that the Maths will become easier with practice.

As far as possible the workbook is organized on a weekly basis. Go through the examples and work out the solution *yourself* on paper then check the solution. A full solution is there for you to check that you are correct and to show my method of solving the problem. To begin with, the solutions give every single step but as you progress through the workbook the explanations become less detailed. When you do finally cover the Chemistry involved in the examples during your Chemistry degree you won't be blinded or scared by the Maths, as by then you will be happy playing around with equations.

Advanced Maths for Chemists may be used with any Maths textbook, however, it is designed to interface with the textbook (Stroud and Booth 2007). Despite its name of *Engineering Mathematics* Stroud and Booth's book covers all the Maths needed by *all* the sciences and engineering subjects. Advanced Maths for Chemists gives chemical examples of the Maths concepts. If you want to look up any first year chemistry then any General Chemistry textbook is useful but the textbook (Blackman, Bottle, Schmid, Mocerino & Wille 2012) is excellent. For later on in your course then (Atkins & de Paula 2009) and (Levine 2009) have many examples of the interplay between Chemistry and Maths mainly in the area of Physical Chemistry.

One final comment. A common mistake of many students is thinking you need to memorize all the equations you come across in any area of the subject. This is *impossible* but there are a *very small number* of equations that become familiar by usage and which you remember without really having to try. All the rest comes from being able to apply your Maths to these familiar equations (or to the equations supplied in an exam or from a textbook) and this enables you to get to your target.

1. Week 1: Chemical Data: Linear Least Squares Curve Fitting

1.1 Least Squares Curve Fitting

Least square fitting is usually made out to be more difficult than it really is or it is treated as a spreadsheet “black art”. I am going to spend some time explaining the fundamentals which are very easy to follow. Typically in a lab experiment we have 3 to 6 data points (x_i, y_i) and we would like the best straight line through them. An excellent explanation of least squares fitting is given by Stroud and Booth 2007, p750, also you may want to look again at section 1.1.4 of the Introductory Maths for Chemists (Parker 2011) on linear graphs. As well as the linear function,

$$y = mx + c$$

any function $f(x_i)$ that is capable of being plotted as a linear graph may have the data points fitted by the least squares method; some of the more chemically useful are listed (a and b are constants). A log function gives a straight line from a semi-log plot of y against $\ln(x)$ with gradient = a and intercept = b .

$$y = a \ln(x) + b$$

A power function gives a straight line from a log-log plot of $\ln(y)$ against $\ln(x)$ with gradient = b and intercept = $\ln(a)$.

$$y = ax^b$$

An exponential function gives a straight line from a semi-log plot of $\ln(y)$ against x with gradient = $\ln(b)$ and intercept = $\ln(a)$.

$$y = ab^x$$

A reciprocal function gives a straight line from a semi-reciprocal plot of y against $1/x$ with gradient = b and intercept = a .

$$y = a + \frac{b}{x}$$

In Week 1 we cover linear curve fitting. Week 2 we will discuss non-linear curve fitting and fitting your own model functions to experimental data.

1.1.1 Linear Least Squares (LLSQ) Curve Fitting

For a linear or straight line function we want to find the function,

$$f(x) = mx + c$$

which most closely fits our data points. That is, for a linear graph we need to discover the gradient m and the intercept c which gives this best fit to our data. Firstly we assume our values of the independent variable x have *no* error (or negligible error) but that the dependent variable y may have an appreciable random scatter.

An individual data point (x_i, y_i) has a residual, R , which is defined as the difference between the experimental data y_i and the value of y_i that is predicted by the model equation straight line $y_i = mx_i + c$.

$$R = y_i - (mx_i + c)$$

Removing the bracket the residual is,

$$R = y_i - mx_i - c$$

We take the square of the individual residuals, SR , to give equal weight to those data points which lie above the predicted line and those that lie below the line predicted of the model equation.

$$SR = (y_i - mx_i - c)^2$$

We take the sum the square of the residuals, SSR , of each of the data points to give an *overall* picture of the scatter of *all* the n data points. The sum of square of all the residuals SSR is,

$$SSR = \sum_{i=1}^n (y_i - mx_i - c)^2$$

where n = number of data points. We will obtain the best fit for a straight line graph by minimizing the value of the sum of squares of the residuals by varying the values of x_1 and c , hence the common name of a “least square” fit. This best fit line is called the linear least squares (LLSQ) line. The easiest way of curve fitting of equations to experimental data is to use a spreadsheet. You can use LibreOffice Calc, or OpenOffice Calc, which are both open-source and free, or Microsoft Excel, see the References. In Calc or Excel you use an array function called LINEST (“lin est”) to fit a linear equation.

The LINEST algorithm works by an iterative process. It increases m by a small amount and then decreases m by the same small amount. It then compares the original SSR with these two altered values and chooses the value for m which leads to the smallest of these three SSR values. Holding this value of m constant for the moment, the algorithm then alters the intercept c by increasing and decreasing it and choosing the value of c which gives the smallest of the resulting three SSR values. LINEST then keeps repeating the above pair of cycles for the two variables until the final value of SSR is only changing by an insignificant amount. Let us look at a worked example as the best way of seeing how LLSQ curve fitting works.

1.1.2 Spectrophotometer Absorption Measurement of Protein Concentration

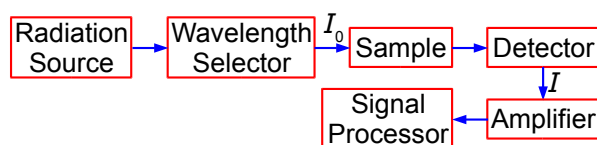

Figure 1.1: schematic diagram of a spectrophotometer.

PREPARE FOR A LEADING ROLE.

English-taught MSc programmes in engineering: Aeronautical, Biomedical, Electronics, Mechanical, Communication systems and Transport systems. No tuition fees.

→ liu.se/master

li.u LINKÖPING UNIVERSITY

A protein has been complexed with a molecule to form a compound that absorbs in the UV-visible range of the spectrum. In the Chemistry lab we use a spectrophotometer, see Fig. 1.1, to measure the absorption of the light. White light from a radiation source is selected for the wavelength at which the complex has a strong absorption. The selected wavelength has an intensity I_0 which is passed through a known concentration of the complex, c mol L⁻¹, and a known length of the sample, l cm. The intensity of the light will be reduced by absorption of the complex to an intensity I . The $\log(I_0/I)$ is called the absorbance, A , of the solution and from the Beer-Lambert law, see below, the absorbance is proportional to the concentration of the absorbing molecule, c , the length of the sample, l , and the absorption coefficient of the molecule, ϵ . The absorption coefficient of the molecule ϵ varies with the wavelength of light and hence the need for using monochromatic light.

$$A = \log\left(\frac{I_0}{I}\right) = \epsilon c l$$

Fig. 1.2 is the initial spreadsheet of different known concentrations of the protein-complex and their absorbances. Fitting a line through the data points gives us a calibration curve for the complex. Obtaining the calibration curve means that we can measure an *unknown* concentration of the complex, *e.g.* obtained from a patient in a hospital.

	A	B
1	Protein/ μ g	A
2	0	-0.0020
3	5	0.0874
4	10	0.1760
5	15	0.2467
6	20	0.3274

Figure 1.2: initial spreadsheet for Beer-Lambert calibration line.

To use the function LINEST we firstly select a *blank* area of the spreadsheet of 2 columns by 5 rows, let's assume this array of blank cells is D3 to E7. While this array of blank cells is still selected (high lighted) you enter your LINEST array-equation in the function window of the spreadsheet as,

$$= \text{LINEST}(B2:B6, A2:A6, 1, 1)$$

These four parameters within LINEST have the following meanings. The cells B2:B6 are the y -data and the cells A2:A6 are the x -data. The third parameter is a switch; if for good chemical reasons you want the line to go through the origin (0, 0) then set this parameter to 0, otherwise to find the intercept set it to 1. The fourth parameter is also a switch, if it is set to 0 then only the gradient and intercept are calculated, we will set it to 1 to obtain all the other statistics as well. These four parameters are separated by commas. Do *not* click on the arrow next to the function window and *do not* press return as this LINEST formula is an *array* formula, the array is from A2 to E7, instead enter the array formula with *shift-control-return* on a PC or *command-return* on a Mac. The blank cells you selected will now fill up with the LLSQ fitted parameters as in Fig. 1.3.

	A	B	C	D	E	F
1	Protein/ μg	A		LINEST Output		
2	0	-0.0020		Gradient	Intercept	
3	5	0.0874	Parameter	0.016362	0.003480	
4	10	0.1760	Std Dev	0.000416	0.005091	
5	15	0.2467	r^2	0.998067	0.006573	Std Dev of y
6	20	0.3274	F	1549.289	3	Deg Freedom
7			SS_{reg}	0.066929	0.000130	SSR

Figure 1.3: final spreadsheet of Beer-Lambert calibration.

I have typed labels into the spreadsheet in columns C and F to help us understand the statistics produced. In cell D3 is the gradient m and E3 the intercept c . D4 is the standard deviation of the gradient σ_m and E4 the standard deviation of the intercept σ_c . D5 is the correlation coefficient r^2 which for a good fit should be a number close to but less than unity. Of the other statistics, the ones of interest are E6 the number of degrees of freedom which is the number of data points, 5 in this example, minus the number of coefficients to be fitted, 2 for m and c , so in this example the number of degrees of freedom is 3. E7 is the minimized value of the SSR of the fitted line which has been minimized by the LINEST algorithm of the spreadsheet.

We quote the equation for our least squares line with the *first* decimal figure of the standard deviations (rounded if necessary) giving us the *last* decimal figure of the gradient and the intercept (also rounded if necessary). The LINEST fitted Beer-Lambert law calibration line is,

$$A = (0.0164 \pm 0.0004 \mu\text{g}^{-1})(c \mu\text{g}) + (0.003 \pm 0.005)$$

From our model equation (the Beer-Lambert law) the absorbance is dimensionless $A = \log(I_0/I)$ and should pass through the origin. The graph of A against c is shown in Fig. 1.4 and the gradient m should have a gradient of units $1/c$ or μg^{-1} . The intercept has the units of A and is dimensionless. A graph should always be plotted to check that no mistakes have been made and there is not a rogue data point that needs to be either measured again or not plotted as it distorts the data too much. The line shown in Fig. 1.4 is our LLSQ line from the LINEST spreadsheet.

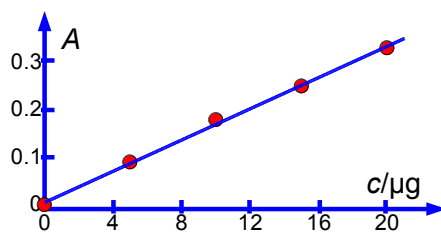

Figure 1.4: Beer-Lambert law LLSQ fit.

The relative precision of the gradient and the intercept are,

$$\frac{\sigma_m}{m} = \frac{0.0004}{0.0164} = 0.02439 = 2.4\%$$

$$\frac{\sigma_c}{c} = \frac{0.005}{0.003} = 1.666 = 167\%$$

Clearly interpolating within the range 0 to 20 μg of protein for the unknown sample is valid, but extrapolating for an amount of protein greater than 20 μg should definitely *not* be attempted due to the large uncertainty in the intercept. Looking at the graph in Fig. 1.4 we might be tempted to try extrapolation but the size of the standard deviation of the intercept tells us that we would need to make experimental measurements at higher concentrations and not extrapolate the graph.

Click here to learn more

TAKE THE RIGHT TRACK

Give your career a head start by studying with us. Experience the advantages of our collaboration with major companies like **ABB, Volvo and Ericsson!**

Apply by 15 January

World class research

www.mdh.se

MÄLARDALEN UNIVERSITY SWEDEN

You may also wonder about forcing the LINEST line through the origin of the graph. This accomplished by selecting the cells where the statistics are displayed, D3:E7, altering the third parameter from 1 to 0 as below,

$$= \text{LINEST}(B2:B6, A2:A6, 0, 1)$$

and then pressing control-shift-return on a PC. The spreadsheet now looks like Fig. 1.5.

	A	B	C	D	E	F
1	Protein/ μg	A		LINEST Output		
2	0	-0.0020		Gradient	Intercept	
3	5	0.0874	Parameter	0.016594	0	
4	10	0.1760	Std Dev	0.000223	#N/A	
5	15	0.2467	r^2	0.999275	0.006119	Std Dev of y
6	20	0.3274	F	5515.195	4	Deg Freedom
7			SS_{reg}	0.206521	0.000150	SSR

Figure 1.5: LLSQ fit for the line when forced through the origin.

As we have now forced the line through the origin there is zero error in the intercept, and the standard deviation of the gradient is about half its previous size at 1.2%.

$$\frac{\sigma_m}{m} = \frac{0.0002}{0.0166} = 0.01205 = 1.2\%$$

The degrees of freedom has increased from 3 to 4 as the intercept is now a constant and not a variable. Perhaps the only thing to give us any slight concern is that now $SSR \approx 0.00015$ whereas previously it was ≈ 0.00013 . Despite the low standard deviation, extrapolation is still dangerous without any evidence that the curve continues to be linear, in fact further experiments show it starts to become slightly curved above about 20 μg of protein. The Beer-Lambert Law fit for our data when we force the line through the origin is,

$$A = (0.0166 \pm 0.0002 \mu\text{g}^{-1})(c \mu\text{g})$$

Let us use LINEST to carry out some LLSQ curve fitting questions.

1.2 Week 1 Tutorial Questions

1.2.1 Question 1: Enthalpy of Fusion of n -Carboxylic Acids

Fig. 1.6 shows the enthalpy of fusion ΔH_{fusion} of four linear saturated carboxylic acids as a function of n the number of carbon atoms in the molecule.

	A	B
1	n	$\Delta H_{\text{fusion}} / \text{kJ mol}^{-1}$
2	6	15.06
3	8	21.38
4	10	29.40
5	12	36.70

Figure 1.6: enthalpy of fusion of n-carboxylic acids.

Use LINEST to find the equation that correlates the enthalpy of fusion of the carboxylic acids with the number of C-atoms in their length and also find the precisions of the gradient and intercept. Organic chemists use this type of equation to correlate *large* tables of experimental data (not just the 4 pieces of data shown here). Finally draw a graph of the data with your LLSQ line shown.

[Jump to Solution 1 \(see page 23\)](#)

1.2.2 Question 2: Electrochemistry and Thermodynamics

The following redox reaction,

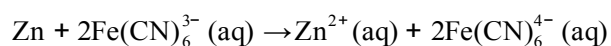

was run as an electrochemical cell, Fig. 1.7.

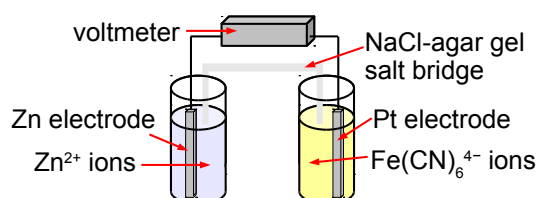

Figure 1.7: schematic diagram of the electrochemical cell.

A student measured the cell voltage E to the nearest millivolt at various temperature T , Fig. 1.8.

	A	B
1	T / K	E / V
2	275	1.255
3	277	1.249
4	279	1.244
5	281	1.239
6	283	1.234
7	285	1.231
8	287	1.228
9	289	1.223
10	291	1.219
11	293	1.215
12	295	1.211
13	297	1.206
14	299	1.202
15	301	1.198
16	303	1.193
17	305	1.189
18	307	1.185
19	309	1.181
20	311	1.177
21	313	1.172
22	315	1.169
23	317	1.165
24	319	1.16
25	321	1.154
26	323	1.15
27	325	1.147

Figure 1.8: cell voltage and temperature.

The cell voltage is related to the entropy and enthalpy of the redox reaction by the equation,

$$E = -\frac{\Delta H}{nF} + \frac{T \Delta S}{nF}$$

Where n is the number of electrons transferred in the redox reaction ($n = 2$ in this case) and the Faraday constant $F = 9.6485 \times 10^4 \text{ C mol}^{-1}$. Type up your own spreadsheet and use LINEST to determine ΔH and ΔS from a linear graph of E against T . What are the precisions of ΔH and ΔS and also their relative precisions?

[Jump to Solution 2 \(see page 24\)](#)

1.2.3 Question 3: The Visible Spectrum of Iodine

The I_2 molecule absorbs at the red-end of the visible spectrum and thus appears bluish-purple. Fig. 1.9 shows the visible absorption spectrum taken using the teaching lab UV-visible spectrophotometer in Heriot-Watt University Chemistry Department.

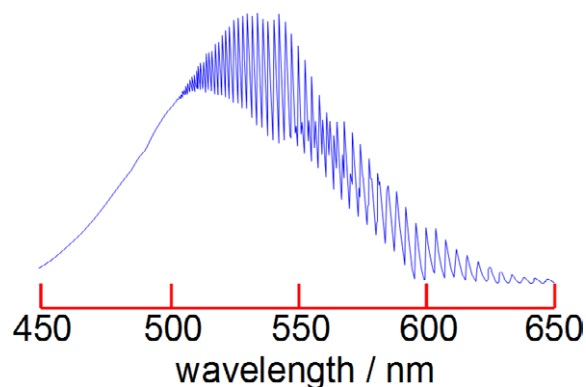

Figure 1.9: visible spectrum of iodine.

The fine structure is called a vibrational progression and it runs from at least 650 nm down to about 500 nm when it becomes continuous *i.e.* non-quantized. The vibrational level ν'_{\max} around 500 nm at which it becomes non-quantized is at the dissociation limit of the *excited* electronic state and thus the absorption spectrum changes from a quantized spectrum to a continuous spectrum with increasing energy of the photons absorbed. This allows us to measure in the lab the energy to jump from $\nu = 0$ of the ground electronic state to the ν'_{\max} the dissociation limit as shown in Fig. 1.10. Spectroscopy will be covered fully in your Chemistry lectures later in your degree.

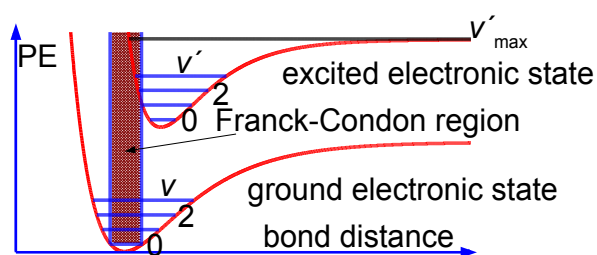

Figure 1.10: schematic PE curves for a diatomic molecule.

In Fig. 1.11 the spreadsheet of the absorption spectrum has column B with the wavelengths λ/nm of the peaks for the transitions from $\nu = 0$ to the various ν' (column A) in the excited state. Wavelength is not proportional to energy but wavenumber $G(\nu')/\text{cm}^{-1}$ is proportional to energy, and so the peaks of the vibrational progression are given in wavenumbers in column C of Fig. 1.11.

	A	B	C	D	E
1	ν'	λ/nm	$G(\nu')/\text{cm}^{-1}$	$\Delta G(\nu'+\frac{1}{2})$	$\nu'+\frac{1}{2}$
2	16	577.1	17,328		
3	17	573.7	17,431	103	16.5
4	18	570.7	17,522	92	17.5
5	19	567.4	17,624	102	18.5
6	20	564.5	17,715	91	19.5
7	21	561.5	17,809	95	20.5
8	22	558.7	17,899	89	21.5
9	23	556.1	17,982	84	22.5
10	24	553.3	18,073	91	23.5
11	25	551.0	18,149	75	24.5
12	26	548.3	18,238	89	25.5
13	27	545.8	18,322	84	26.5
14	28	543.6	18,396	74	27.5
15	29	541.4	18,471	75	28.5
16	30	539.1	18,549	79	29.5
17	31	537.0	18,622	73	30.5
18	32	535.0	18,692	70	31.5
19	33	532.9	18,765	74	32.5
20	34	531.1	18,829	64	33.5
21	35	529.4	18,889	60	34.5
22	36	527.5	18,957	68	35.5
23	37	525.8	19,019	61	36.5
24	38	524.2	19,077	58	37.5
25	39	522.8	19,128	51	38.5
26	40	521.4	19,179	51	39.5
27	43	517.2	19,335		
28	44	516.0	19,380	45	43.5
29	45	514.8	19,425	45	44.5
30	46	513.6	19,470	45	45.5
31	47	512.5	19,512	42	46.5
32	48	511.4	19,554	42	47.5
33	49	510.5	19,589	34	48.5
34	50	509.6	19,623	35	49.5
35	51	508.8	19,654	31	50.5
36	52	508.0	19,685	31	51.5
37	53	507.2	19,716	31	52.5
38	54	506.5	19,743	27	53.5
38	55	505.8	19,771	27	54.5
40	56	505.0	19,802	31	55.5
41	57	504.5	19,822	20	56.5
42	58	503.9	19,845	24	57.5
43	59	503.4	19,865	20	58.5
44	60	502.9	19,885	20	59.5
45	61	502.4	19,904	20	60.5
46	62	502.0	19,920	16	61.5

Figure 1.11: initial spreadsheet of iodine visible absorption spectrum.

Type up your own spreadsheet for Columns A to E. The spectrum in Fig. 1.9 shows that we only have peaks for the middle part of the progression, we don't know the wavelength of the $\nu = 0$ to $\nu' = 0$ transition as it is beyond the range of our spectrometer and so we need to look at the *energy differences* between *neighbouring* peaks. Column D of your spreadsheet should calculate $\Delta G(\nu'+\frac{1}{2})$

$$\Delta G(\nu'+\frac{1}{2}) = G(\nu'+1) - G(\nu')$$

You will notice that there is missing data for transitions to $\nu' = 41$ and 42 . Such missing data is common in science, so think *carefully* about how your spreadsheet can best handle the *missing data* points for the next step. The summation of these $\Delta G(\nu'+\frac{1}{2})$ is equal to the dissociation energy in the excited electronic state, D_0' .

$$D_0' = \sum \Delta G(\nu'+\frac{1}{2})$$

The best way of proceeding when you don't have the data from outside the spectrometer's range is to fit a straight line through the graph of $\Delta G(\nu'+\frac{1}{2})$ against $(\nu'+\frac{1}{2})$. From the equation for the line solve it to find where the line crosses the x -axes *i.e.* the x -intercept. This extrapolation of a vibrational progression in spectroscopy is called the Birge-Sponer extrapolation. Extrapolation is always a worrying thing so finding the standard deviations of the gradient and intercept is very important. Once we have the x -intercept from the equation as well as the gradient and the y -intercept we can evaluate the D_0' graphically as the area under the triangle of the $\Delta G(\nu'+\frac{1}{2})$ against $(\nu'+\frac{1}{2})$ line.

[Jump to Solution 3 \(see page 26\)](#)

1.2.4 Question 4: Arrhenius Plot

Fig. 1.12 shows the experimental data from a student lab experiment to measure the first-order rate constant of a chemical reaction against temperature.

	A	B
1	T / K	k / s^{-1}
2	293	0.00526
3	298	0.00756
4	303	0.0144
5	308	0.0227
6	313	0.0483
7	318	0.0621
8	323	0.119

Figure 1.12: first-order rate constant and temperature data.

The Arrhenius equation can be transformed into a linear equation by taking logs on both sides and plotting the linear equation $\ln(A)$ against $1/T$, this transformed graph is called an Arrhenius plot.

$$k = A \exp\left(-\frac{E_a}{RT}\right) \quad \ln(k) = \ln(A) - \frac{E_a}{RT}$$

The intercept of the Arrhenius plot is $c = \ln(A)$ and the gradient $m = -E_a/R$. Type up your own spreadsheet, transform the data and find the pre-exponential factor A and the activation energy E_a and their precisions. Do you notice anything worrying about your LLSQ fitted line when you graph it?

[Jump to Solution 4 \(see page 29\)](#)



**WE ARE SHAPING
MOBILITY FOR
TOMORROW**

How will people travel in the future, and how will goods be transported? What resources will we use, and how many will we need? The passenger and freight traffic sector is developing rapidly, and we provide the impetus for innovation and movement. We develop components and systems for internal combustion engines that operate more cleanly and more efficiently than ever before. We are also pushing forward technologies that are bringing hybrid vehicles and alternative drives into a new dimension – for private, corporate, and public use. The challenges are great. We deliver the solutions and offer challenging jobs.

www.schaeffler.com/careers

SCHAEFFLER



1.3 Week 1 Tutorial Solutions

1.3.1 Solution 1: Enthalpy of Fusion of *n*-Carboxylic Acids

Fig. 1.13 shows the final spreadsheet using LINEST.

	A	B	C	D	E
1	<i>n</i>	$\Delta H_{\text{fusion}} / \text{kJ mol}^{-1}$			
2	6	15.06		3.647	-7.188
3	8	21.38		0.115	1.070
4	10	29.40		0.998	0.516
5	12	36.70		998.319	2
6				266.012	0.533

Figure 1.13: enthalpy of *n*-carboxylic acids fitted by LINEST.

Taking account of the standard deviations, the fitted equation for the enthalpy variation is,

$$\Delta H_{\text{fusion}} = (3.6 \pm 0.1 \text{ kJ mol}^{-1})n - (7 \pm 1 \text{ kJ mol}^{-1})$$

Notice how the intercept is much less precise (14% relative precision) compared to the gradient (3%) so extrapolation is *not* recommended. However, with more data (such as from a large tabulation of data) the precision of the LLSQ correlation line would improve markedly and become really useful in organic chemistry. Also with more data you would find that you need two slightly different linear equations for *n* with even and odd numbers of C-atoms. Finally we should always check our results by plotting a graph to see if any of the points are rogue ones and to confirm that the fitted line is sensible, Fig. 1.14.

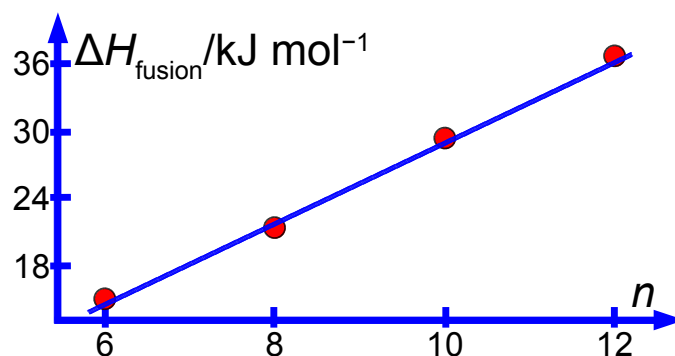

Figure 1.14: LINEST fit for enthalpies of fusion.

[Return to Question 1 \(see page 16\)](#)

1.3.2 Solution 2: Electrochemistry and Thermodynamics

	A	B	C	D
1	T / K	E / V		
2	275	1.255		
3	277	1.249	-0.002121	1.836256
4	279	1.244	0.000011	0.003326
5	281	1.239	0.999347	0.000847
6	283	1.234	36705	24
7	285	1.231	0.026326	0.000017
8	287	1.228		
9	289	1.223		
10	291	1.219		
11	293	1.215		
12	295	1.211		
13	297	1.206		
14	299	1.202		
15	301	1.198		
16	303	1.193		
17	305	1.189		
18	307	1.185		
19	309	1.181		
20	311	1.177		
21	313	1.172		
22	315	1.169		
23	317	1.165		
24	319	1.16		
25	321	1.154		
26	323	1.15		
27	325	1.147		

Figure 1.15: LLSQ LINEST fit of cell voltage and temperature.

The LLSQ line through the E versus T data with units is,

$$E = (-0.00212 \pm 0.00001 \text{ V K}^{-1})(T \text{ K}) + (1.836 \pm 0.003 \text{ V})$$

Plotting the graph let's see if we have made any miscalculation and whether there are any rogue points which may well need remeasuring in the lab, also a graph is required to complete your lab report, Fig. 1.16.

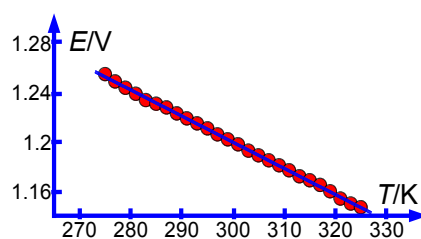

Figure 1.16: LLSQ line for E versus T data.

From the intercept for the graph and our thermodynamic equation we have,

$$E = -\frac{\Delta H}{nF} + \frac{T\Delta S}{nF}$$

$$\Delta H = (-1.836 \pm 0.003 \text{ V})(2 \times 9.6485 \times 10^4 \text{ C mol}^{-1})$$

$$\Delta H = (-354.293, \downarrow -354.872, \uparrow -353.714) \text{ kJ mol}^{-1}$$

We have used the fact that 1 coulomb-volt equals 1 joule. I have used an up and a down arrow to show the plus and minus values for ΔH at this intermediate stage and to reduce rounding errors an excess of significant figures is quoted. It is in the first decimal place, after rounding, that the three values vary thus,

$$\Delta H = (-354.3 \pm 0.6) \text{ kJ mol}^{-1}$$

The gradient leads to,

$$\Delta S = (-0.00212 \pm 0.00001 \text{ V K}^{-1})(2 \times 9.6485 \times 10^4 \text{ C mol}^{-1})$$

$$\Delta S = (-409.0964, \downarrow -411.0261, \uparrow -407.1667) \text{ J K}^{-1} \text{ mol}^{-1}$$

$$\Delta S = (-409 \pm 2) \text{ J K}^{-1} \text{ mol}^{-1}$$

It is noticeable that the relative standard deviation of ΔH is ~0.2%, whereas ΔS is ~0.5%. We have tried to reduce rounding errors in the different stages of the data processing and to show the importance of finding the standard deviations of the gradient and intercept and not just m and c themselves.

[Return to Question 2 \(see page 17\)](#)

1.3.3 Solution 3: The UV-Visible Spectrum of Iodine

	A	B	C	D	E	F	G	H	I
1	ν'	λ/nm	$G(\nu')/\text{cm}^{-1}$	$\Delta G(\nu'+\frac{1}{2})$	$\nu'+\frac{1}{2}$	$\Delta G(\nu'+\frac{1}{2})$	$\nu'+\frac{1}{2}$		
2	16	577.1	17,328						
3	17	573.7	17,431	103	16.5	103	16.5	-1.893	130.174
4	18	570.7	17,522	92	17.5	92	17.5	0.043	1.750
5	19	567.4	17,624	102	18.5	102	18.5	0.980	3.822
6	20	564.5	17,715	91	19.5	91	19.5	1983.872	41
7	21	561.5	17,809	95	20.5	95	20.5	28983.986	599.002
8	22	558.7	17,899	89	21.5	89	21.5		
9	23	556.1	17,982	84	22.5	84	22.5		
10	24	553.3	18,073	91	23.5	91	23.5		
11	25	551.0	18,149	75	24.5	75	24.5		
12	26	548.3	18,238	89	25.5	89	25.5		
13	27	545.8	18,322	84	26.5	84	26.5		
14	28	543.6	18,396	74	27.5	74	27.5		
15	29	541.4	18,471	75	28.5	75	28.5		
16	30	539.1	18,549	79	29.5	79	29.5		
17	31	537.0	18,622	73	30.5	73	30.5		
18	32	535.0	18,692	70	31.5	70	31.5		
19	33	532.9	18,765	74	32.5	74	32.5		
20	34	531.1	18,829	64	33.5	64	33.5		
21	35	529.4	18,889	60	34.5	60	34.5		
22	36	527.5	18,957	68	35.5	68	35.5		
23	37	525.8	19,019	61	36.5	61	36.5		
24	38	524.2	19,077	58	37.5	58	37.5		
25	39	522.8	19,128	51	38.5	51	38.5		
26	40	521.4	19,179	51	39.5	51	39.5		
27	43	517.2	19,335			45	43.5		
28	44	516.0	19,380	45	43.5	45	44.5		
29	45	514.8	19,425	45	44.5	45	45.5		
30	46	513.6	19,470	45	45.5	42	46.5		
31	47	512.5	19,512	42	46.5	42	47.5		
32	48	511.4	19,554	42	47.5	34	48.5		
33	49	510.5	19,589	34	48.5	35	49.5		
34	50	509.6	19,623	35	49.5	31	50.5		
35	51	508.8	19,654	31	50.5	31	51.5		
36	52	508.0	19,685	31	51.5	31	52.5		
37	53	507.2	19,716	31	52.5	27	53.5		
38	54	506.5	19,743	27	53.5	27	54.5		
38	55	505.8	19,771	27	54.5	31	55.5		
40	56	505.0	19,802	31	55.5	20	56.5		
41	57	504.5	19,822	20	56.5	24	57.5		
42	58	503.9	19,845	24	57.5	20	58.5		
43	59	503.4	19,865	20	58.5	20	59.5		
44	60	502.9	19,885	20	59.5	20	60.5		
45	61	502.4	19,904	20	60.5	16	61.5		
46	62	502.0	19,920	16	61.5				

Figure 1.17: LINEST fit for I_2 by Birge-Sponer extrapolation.

Because of the missing data for ν' 41 and 42 the energy difference of 43–40 is anomalously large at 155.7 cm^{-1} at D27 and has been deleted from the spreadsheet, otherwise it would distort the curve fitting. If we try to use LINEST directly on columns D and E then it throws up an error. This is because of the blank cells due to the missing data are treated as text and you can't have text in the middle of a numerical array. This is easily fixed. Columns D and E are selected and copied. Selecting the blank column F click on Edit then Paste Special, and the window shown in Fig. 1.18 appears in Calc (or the equivalent window in Excel). Deselect "Paste all" and select "Text", "Numbers" and "Skip empty cells" and leave the other options alone. Press OK and the amended copy of D and E is copied into F and G but without the blank cells.

**STUDY FOR YOUR MASTER'S DEGREE
IN THE CRADLE OF SWEDISH ENGINEERING**

Chalmers University of Technology conducts research and education in engineering and natural sciences, architecture, technology-related mathematical sciences and nautical sciences. Behind all that Chalmers accomplishes, the aim persists for contributing to a sustainable future – both nationally and globally.

Visit us on Chalmers.se or **Next Stop Chalmers** on facebook.

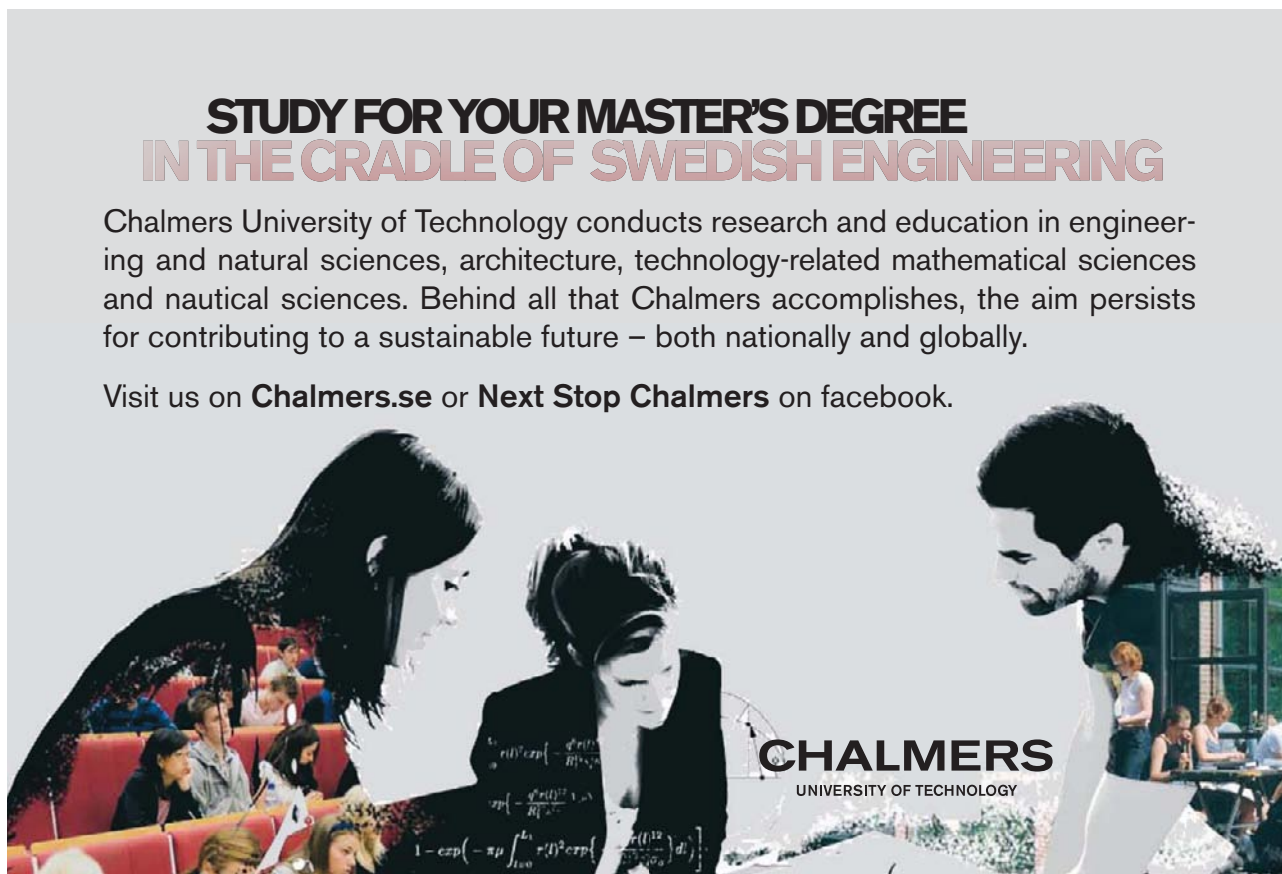

CHALMERS
UNIVERSITY OF TECHNOLOGY



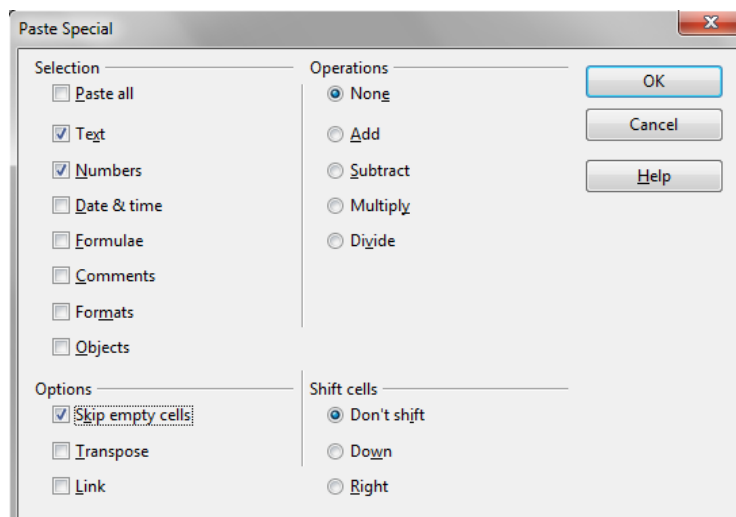

Figure 1.18: paste special window in Calc.

Select a 2 column by 5 row blank area and enter the LINEST equation into the formula window while the cells are still selected and then press Shift-Control-Return on a PC or Command-Return on a Mac,

$$= \text{LINEST}(F3:F45, G3:G45, 1, 1)$$

Taking account of the standard deviations the equation of the Birge-Sponer extrapolation is thus,

$$\Delta G(v' + \frac{1}{2}) = (-1.89 \pm 0.04 \text{ cm}^{-1})(v' + \frac{1}{2}) + (130 \pm 2 \text{ cm}^{-1})$$

The relative precisions are about 2% for the gradient and about 2% for the intercept, which is good precision for an undergraduate lab experiment and reflects the both scatter seen in the graph of Fig. 1.19 but also reflects the advantage of the large number of data points in the experiment.

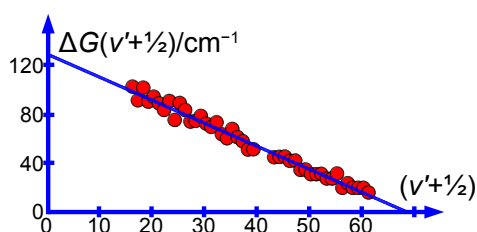

Figure 1.19: LINEST fit for Birge-Sponer extrapolation for I_2 .

The I_2 molecule dissociation limit of the excited electronic state, *i.e.* the intercept on the x -axis (rather than the y -intercept) is given by the equation of the line and is when $\Delta G(v' + \frac{1}{2}) = 0$ we have,

$$0 = (-1.89 \pm 0.04 \text{ cm}^{-1})(v'_{\text{limit}} + \frac{1}{2}) + (130 \pm 2 \text{ cm}^{-1})$$

$$v'_{\text{limit}} + \frac{1}{2} = 68.8 \uparrow 71.4 \downarrow 66.3 \text{ cm}^{-1}$$

Where I use and up and down arrow to show the maximum and minimum values obtained.

$$\nu'_{\text{limit}} + \frac{1}{2} = 69 \pm 3 \text{ cm}^{-1}$$

Where the precision of the x -intercept is found by firstly, using the maximum value of m and the minimum value of c ; and secondly, the minimum value of m and the maximum value of c . We have treated $(\nu' + \frac{1}{2})$ as a continuous variable as we must in order to use the least squares fitting procedure and to find the area under the curve. However as ν' is actually quantized then the *last* quantized transition would be to $\nu'_{\text{limit}} = 69 \pm 3$ and any non-quantized transition above 69 leads to dissociation into two iodine atoms. Note that the scatter in our experiment is considerably limiting the precision but this might not be obvious without the use of LINEST. The dissociation energy of the excited state D_0' is the area under the curve which is triangular and so,

$$D_0' = \frac{1}{2}(69 \pm 3)(130 \pm 2 \text{ cm}^{-1}) = 4485 \uparrow 4752 \downarrow 4224 \text{ cm}^{-1}$$

$$D_0' = 4500 \pm 300 \text{ cm}^{-1}$$

As $1 \text{ cm}^{-1} = 1.9864 \times 10^{-23} \text{ J}$ and $N_A = 6.02214 \times 10^{23} \text{ mol}^{-1}$ the student's lab experiment gives,

$$D_0' = (4500 \pm 300 \text{ cm}^{-1})(1.9864 \times 10^{-23} \text{ J})(6.02214 \times 10^{23} \text{ mol}^{-1})$$

$$D_0' = (53.8 \uparrow 57.4 \downarrow 50.2) \text{ kJ mol}^{-1}$$

$$D_0' = (54 \pm 4) \text{ kJ mol}^{-1}$$

The relative precision of our experimental excited state dissociation energy is about 7%. We have learnt how to handle missing experimental data in the middle and beginning of a data set.

[Return to Question 3 \(see page 19\)](#)

1.3.4 Solution 4: Arrhenius Plot

Type up your own spreadsheet of the T , k , $1/T$ and $\ln(k)$ in columns A, B, C and D. Use LINEST to give a spreadsheet similar to Fig. 1.20.

	A	B	C	D	E	F
1	T / K	k / s^{-1}	$1/T$	$\ln(k)$		
2	293	0.00526	0.003413	-5.248	-9986.79	28.73
3	298	0.00756	0.003356	-4.885	411.32	1.34
4	303	0.0144	0.003300	-4.241	0.99	0.11
5	308	0.0227	0.003247	-3.785	589.52	5
6	313	0.0483	0.003195	-3.030	7.79	0.06609
7	318	0.0621	0.003145	-2.779		
8	323	0.119	0.003096	-2.129		

Figure 1.20: LINEST fit for an Arrhenius plot.

The LINEST fit to the plot of the log form of the Arrhenius equation is,

$$\ln(k) = \ln(A) - \frac{E_a}{RT}$$

$$\ln(k) = (29 \pm 1) + (-10000 \pm 400 \text{ K}) \left(\frac{1}{T} \text{ K}^{-1} \right)$$

From the intercept the pre-exponential factor A is found by taking the anti-log, *i.e.* $\exp(29 \pm 1)$. I have used some extra decimal places to reduce any rounding errors. As it is an exponential scale the error limits are not symmetrical around the mean value. The pre-exponential factor from our LLSQ fitted experimental data is,



Scholarships



Lnu.se

Open your mind to new opportunities

With 31,000 students, Linnaeus University is one of the larger universities in Sweden. We are a modern university, known for our strong international profile. Every year more than 1,600 international students from all over the world choose to enjoy the friendly atmosphere and active student life at Linnaeus University. Welcome to join us!

Linnaeus University

Sweden

Bachelor programmes in
Business & Economics | Computer Science/IT | Design | Mathematics

Master programmes in
Business & Economics | Behavioural Sciences | Computer Science/IT | Cultural Studies & Social Sciences | Design | Mathematics | Natural Sciences | Technology & Engineering

Summer Academy courses



$$A = (3.93 \uparrow 10.69 \downarrow 1.45) \times 10^{12} \text{ s}^{-1}$$

$$A = (4 + 7 - 3) \times 10^{12} \text{ s}^{-1}$$

The activation energy E_a is obtained from the gradient as,

$$-\frac{E_a}{R} = -(10000 \pm 400 \text{ K})$$

$$E_a = (10000 \pm 400 \text{ K})(8.314 \text{ J K}^{-1} \text{ mol}^{-1})$$

$$E_a = (83.14 \uparrow 86.47 \downarrow 79.81) \text{ kJ mol}^{-1}$$

$$E_a = (83 \pm 3) \text{ kJ mol}^{-1}$$

The relative errors of the pre-exponential factor are between +175% and -75% and so extrapolation should be avoided. However, the relative error of the activation energy is fairly small at 4%. Fig. 1.21 shows the Arrhenius plot and the LLSQ fitted equation in red.

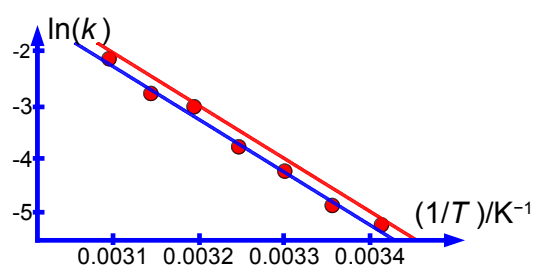

Figure 1.21: Arrhenius plot with LINEST fitted lines.

The red line in Fig. 1.21 is the LINEST statistically more reliable line taking the standard deviations into account by plotting $\ln(k) = 29 - (10000/T)$. The blue line is the LINEST fit *without* taking into account the standard deviations of the gradient and intercept by plotting $\ln(k) = 28.7 - (9987/T)$. The blue line is probably what you would obtain by using a plastic ruler and drawing a line by “eye” (which is how such plots were originally treated) and it is a pretty good fit!

So what is going on? We are *not* plotting a y versus x graph but a *transformed* graph of $\ln(y)$ versus $1/x$. In Fig. 1.22, using the current data points, we have plotted the reciprocal of the temperature against the temperature which gives a linear plot with an excellent goodness of fit of $r^2 = 0.9992$ over this *limited* temperature range.

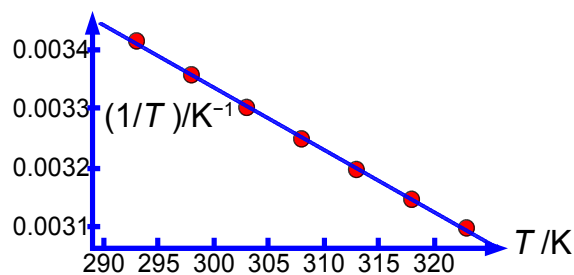

Figure 1.22: $1/T$ versus T for the Arrhenius experimental data.

Conversely, Fig. 1.23 shows that the plot of the natural log of the rate constant against the rate constant and the graph is markedly curved for the current data.

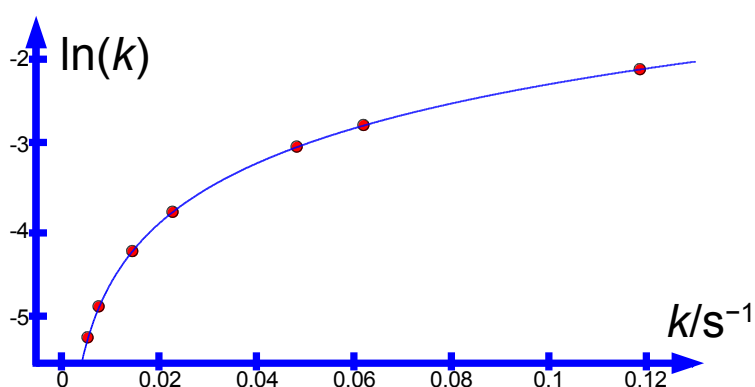

Figure 1.23: $\ln(k)$ versus k for the Arrhenius experimental data.

At large values of k then $\ln(k)$ is nearly linear with k , but at small values of k the log increases rapidly. These small rate constants will also be more difficult to measure accurately and will have a larger relative error. Perhaps transforming equations in order to obtain a linear Arrhenius plot may not be using the data to its best advantage. We need a non-linear fitting method, a NLLSQ method. This is what we look at next.

[Return to Question 4 \(see page 21\)](#)

2 Week 2: Chemical Data: Non-Linear Least Squares Curve Fitting

2.1 Nonlinear Least Squares (NLLSQ) Curve Fitting

There are many equations and laws in Chemistry which may be plotted as linear graphs, as well as the obvious $y = mx + c$, e.g. log functions $f(x) = a \ln(x) + b$; power functions $f(x) = ax^b$; exponential functions, $f(x) = ab^x$; reciprocal functions, $f(x) = a + b/x$. The transformed functions can be treated by the LLSQ LINEST approach which was covered in Week 1. As we saw with the Arrhenius plot such transformations may *not* use the data to its best advantage. There are also *many* equations and laws that *cannot* be plotted as straight lines e.g. a double log function, $f(x) = a \ln(x) + b \ln(x)$.

In both LibreOffice Calc and OpenOffice Calc the algorithm Solver is part of the software but in Excel you *may* have to install Solver for NLLSQ, see the appropriate web-site. The simplest way of showing how to use this system is using a worked example. I will use LibreOffice Calc but anyone using Excel will find similar instructions.



e-learning for kids

- The number 1 MOOC for Primary Education
- Free Digital Learning for Children 5-12
- 15 Million Children Reached

About e-Learning for Kids Established in 2004, e-Learning for Kids is a global nonprofit foundation dedicated to fun and free learning on the Internet for children ages 5 - 12 with courses in math, science, language arts, computers, health and environmental skills. Since 2005, more than 15 million children in over 190 countries have benefitted from eLessons provided by EFK! An all-volunteer staff consists of education and e-learning experts and business professionals from around the world committed to making difference. eLearning for Kids is actively seeking funding, volunteers, sponsors and courseware developers; get involved! For more information, please visit www.e-learningforkids.org.



2.1.1 NLLSQ Worked Example: Arrhenius Data

We are going to use the data from Section 1.3.4 to directly plot k against T and fit a NLLSQ line using the Arrhenius equation as our model equation. Fig. 2.1 shows column A as our x variable and column B as y . Column C is the calculated value of y using the equation Arrhenius equation, $k(\text{calc}) = A \exp(-E_a/RT)$. So C2 contains the formula,

$$= \$G\$3*EXP(- \$G\$4/(\$G\$5*A2))$$

	A	B	C	D	E	F	G
1	T / K	k / s^{-1}	$k(\text{calc})$	R	SR		
2	293	0.00526	0.999590	-0.994330	0.988691		
3	298	0.00756	0.999596	-0.992036	0.984136	$A =$	1.00E+000
4	303	0.0144	0.999603	-0.985203	0.970625	$E_a =$	1
5	308	0.0227	0.999610	-0.976910	0.954352	$R =$	8.314
6	313	0.0483	0.999616	-0.951316	0.905002		
7	318	0.0621	0.999622	-0.937522	0.878947		
8	323	0.119	0.999628	-0.880628	0.775505		
9				$SSR =$	6.457259		

Figure 2.1: Arrhenius data with $A = 1$ and $E_a = 1$.

In this function the arbitrary constants (*i.e.* the general name for the as yet unknown but soon to be determined constants) A and E_a , are entered as absolute cell references $\$G\3 and $\$G\4 . We will return to the values these constants in a moment. The value for the gas constant R is also entered as cell $\$G\5 .

Column D are the individual residuals R , *e.g.* in cell D2 the following is entered, $=B2-C2$. The residuals squared SR are in column E *e.g.* cell E2, is $=D2^2$. Cells C2, D2 and E2 are copied and then pasted into the cells below. The sum of squares of the residuals SSR in E9 is $=SUM(E2:E8)$. We will find the best straight line by minimizing the SSR by varying the unknown arbitrary constants A and E_a . This minimization of SSR occurs iteratively with A and E_a being altered slightly and randomly and seeing which change leads to a lower value for SSR . In the Solver algorithm we can change the total number of iterations allowed (called the learning cycles) and also the test of when we have reached the minimum for SSR (called the stagnation limit).

There may be several minima in the three-dimensional space (the two arbitrary constants A and E_a and the SSR), but we want to find the lowest minimum, the so-called *global* minimum. Unlike the linear least squared method we need to specify the initial guesses for the two constants using our Chemistry knowledge so that we find the global minimum and not get stuck in a *local* minimum which may solve the Maths but is Chemical nonsense.

For the initial starting values of the arbitrary constants if the values of unity (1) are typed into G3 and G4 the $SSR = 6.457$ and so unity is a poor initial estimate for the constants. In this particular example we already have approximate values for the pre-exponential factor and the activation from the LLSQ LINEST fitting of the transformed equation. So lets use those values. Typing 1E12 into G3 and 80000 into G4 gives us a much better value for SSR of 0.000155 as Fig. 2.2.. This is a better initial estimate than having them as unity. Now we can use the NLLSQ program Solver to automate this iterative process of altering A and E_a to find the global minimum pre-exponential factor and activation energy by a direct NLLSQ fit.

	A	B	C	D	E	F	G
1	T / K	k / s^{-1}	$k(\text{calc})$	R	SR		
2	293	0.00526	0.005463	-0.000203	4.1393E-08		
3	298	0.00756	0.009479	-0.001919	3.6833E-06	$A =$	1.00E+012
4	303	0.0144	0.016150	-0.001750	3.0632E-06	$E_a =$	80000
5	308	0.0227	0.027044	-0.004344	1.8870E-05	$R =$	8.314
6	313	0.0483	0.044546	0.003754	1.4091E-05		
7	318	0.0621	0.072233	-0.010133	1.0268E-04		
8	323	0.119	0.115388	0.003612	1.3047E-05		
9				$SSR =$	0.000155		

Figure 2.2: Arrhenius data with reasonable values for A and E_a .

Notice that the value of the gas constant is in $J K^{-1} mol^{-1}$ and for the units to cancel in the exponential the activation energy must also be in the base unit of $J mol^{-1}$ and is typed in as 80000. I am using LibreOffice Calc but Excel or OpenOffice have similar commands, place the cursor on the SSR cell *i.e.* E9. Click on Tools and then click on Solver. The Solver window that appears as in Fig. 2.3 with the Target cell shown as $\$E\9 .

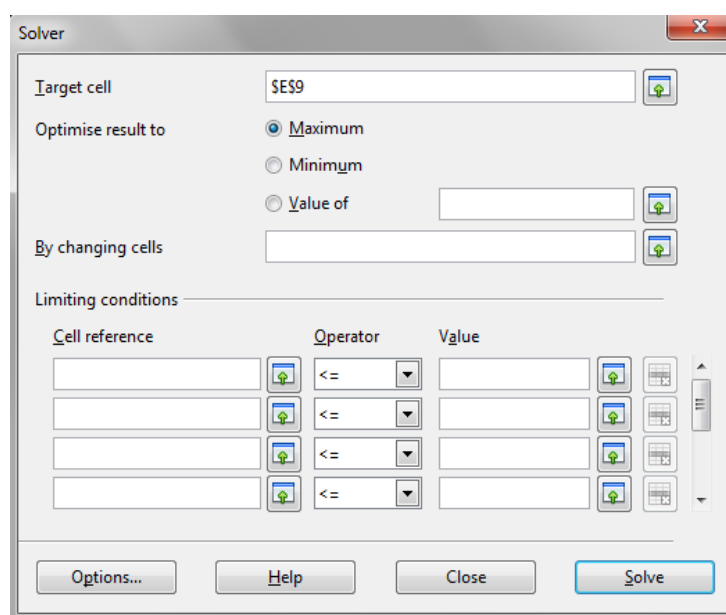

Figure 2.3: Solver Window.

As we need to minimize the SSR we click on “Minimum” in the Solver window. Solver needs to be told where the cells are that it may vary in order to achieve the NLLSQ result. In the Solver window “By changing cells” use the drop down windows to select \$G\$3:\$G\$4. We can speed things up by telling Solver that the pre-exponential factor and activation energy are both positive values. As we know from our Chemistry that the Arrhenius parameters are both positive, using the “Limiting conditions” drop down windows set \$G\$3 \geq 0 and \$G\$4 \geq 0 and this will speed the iterative process. Finally we choose the algorithm to use, click on “Options” and select “DEPS”, then click on “Learning cycles” and edit it from 2,000 to 2,000,000 and then click on “Stagnation limit” and edit it from 70 to 70,000. Click OK and then click “Solve” in the Solver window.

On my laptop it took 11.7 seconds to reach stagnation and used 1,374 cycles of iteration. The final spreadsheet is shown in Fig. 2.4.

	A	B	C	D	E	F	G
1	T / K	k / s^{-1}	$k(\text{calc})$	R	SR		
2	293	0.00526	0.004734	0.000526	0.000000		
3	298	0.00756	0.008427	-0.000867	0.000001	$A =$	4.00E+012
4	303	0.0144	0.014718	-0.000318	0.000000	$E_a =$	83726
5	308	0.0227	0.025244	-0.002544	0.000006	$R =$	8.314
6	313	0.0483	0.042559	0.005741	0.000033		
7	318	0.0621	0.070582	-0.008482	0.000072		
8	323	0.119	0.115238	0.003762	0.000014		
9				$SSR =$	0.000127		

Figure 2.4: Arrhenius data with NLLSQ fitted Arrhenius parameters.

SSR has dropped to 0.000127 and the NLLSQ values for the arbitrary constants are $A = 4 \times 10^{12} \text{ s}^{-1}$ and $E_a = 83.726 \text{ kJ mol}^{-1}$. Remember to save the spreadsheet.

Noting these values for our two arbitrary constants (A and E_a) the question arises what are their precisions? You manually vary each one of the constants in turn and look at the subsequent variations in the SSR. This is easy with a spreadsheet. We increase the first digit in the first constant A and look at the change in SSR. If SSR alters by more than a factor of 10, press the *undo icon* and then move on to the next lower digit. When you find a digit that alters the SSR by less than a factor of ten you may take that as a *reasonable* measure of the precision of the NLLSQ fit for that constant (A). You repeat the procedure for the other constant E_a . Remember *don't save* this “working” spreadsheet. In this way you quickly find that $A = (4 \pm 1) \times 10^{12} \text{ s}^{-1}$ and $E_a = (83.7 \pm 0.1) \text{ kJ mol}^{-1}$. The Arrhenius equation obtained by the NLLSQ fitting of the rate constant and temperature data is shown below and the data is plotted in Fig. 2.5.

$$k = (4 \pm 1 \times 10^{12} \text{ s}^{-1}) \exp\left(\frac{-83700 \pm 100 \text{ J mol}^{-1}}{RT}\right)$$

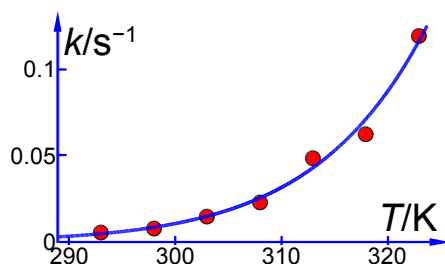

Figure 2.5: rate constant and temperature with NLLSQ fitted curve.

The raw data is best used with a NLLSQ approach rather than a transformation to a linear equation which distorts the data and the relative precisions of the data points. The precisions of the NLLSQ arbitrary constants are found in the same way as we have been using for the LLSQ precisions. The NLLSQ gives more precise (reliable) values for the Arrhenius parameters. LINEST (section 1.3.4) gave us $A = (4 + 7 - 3) \times 10^{12} \text{ s}^{-1}$ and $E_a = (83 \pm 3) \text{ kJ mol}^{-1}$ for the same data. However, LINEST did give us useful initial starting points for the arbitrary constants in the iterative process. It is worth stressing that we don't need to carry out LINEST before using Solver, but we can directly go to the NLLSQ method, as in the following questions.

But in general we can now check *any model equation* against our data to see whether the equation does in fact fit the experimental data.

.....Alcatel-Lucent 

www.alcatel-lucent.com/careers

What if you could build your future and create the future?

One generation's transformation is the next's status quo. In the near future, people may soon think it's strange that devices ever had to be "plugged in." To obtain that status, there needs to be "The Shift".

2.2 Week 2 Tutorial Questions

2.2.1 Question 1: Boiling Points of n -Alkanes

A typical n -alkane (n -nonane) is shown in Fig. 2.6

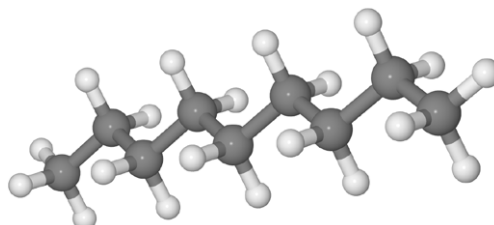

Figure 2.6: n -nonane.

The boiling points (BP K) of some liquid n -alkanes of formula C_nH_{2n+2} are believed to fit the formula shown below. This is an example of the type of equation which organic Chemists use to model large amounts of tabulated data. Clearly here we are using a very small data sample but increasing the number of data points will increase the precision and usefulness of the equation and the model equation will then be a convenient summary.

$$BP = A \log(n + B) - C$$

Type up your own spreadsheet and solve it for the arbitrary constants (A , B , and C) to find the model equation from the data in Fig. 2.7 and then interpolate to find the boiling point of n -nonane and the precision of the predicted boiling point.

	A	B
1	n	BP/K
2	5	309
3	6	342
4	8	399
5	10	447
6	11	469
7	12	489

Figure 2.7: boiling points for some n -alkanes.

[Jump to Solution 1 \(see page 43\)](#)

2.2.2 Question 2: Heat Capacity of Solid Lead

The thermodynamic properties of solids and liquids are accurately modelled by the Shomate equation. For solids the Shomate equation is,

$$C_p = A + Bt + Ct^2 + Dt^3 + \frac{E}{t^2}$$

Where C_p is in $\text{J K}^{-1} \text{mol}^{-1}$ and $t = (T \text{ K})/1000$. Fig. 2.8 shows the measured heat capacity C_p of solid Pb in column C from temperatures near room temperature at 300 K up to 600 K near its boiling point in column A, and in column B the temperatures t .

	A	B	C
1	T / K	$t = T/1000$	$C(p)/\text{J K}^{-1} \text{mol}^{-1}$
2	300	0.30	26.7
3	350	0.35	27.3
4	400	0.40	27.7
5	450	0.45	28.1
6	500	0.50	28.6
7	550	0.55	29.0
8	600	0.60	29.4

Figure 2.8: measured C_p for Pb at various temperatures.

Set up your own spreadsheet to solve the NLLSQ fitting for the Shomate equation for solid lead.

[Jump to Solution 2 \(see page 45\)](#)

2.2.3 Question 3: Ionization of He

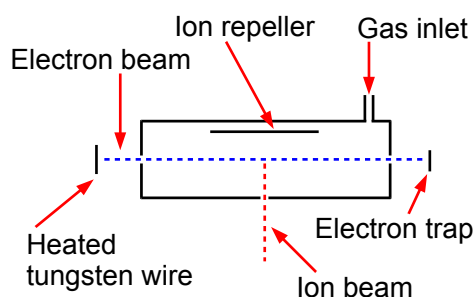
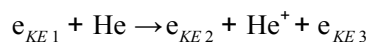

Figure 2.9: mass spectrometer electron-ionization source.

Fig. 2.9 shows a stainless steel source of a mass spectrometer which is inside a vacuum chamber at a pressure of about 10^{-9} atm. A beam of electrons (from a heated tungsten filament) is passed through a low pressure of helium gas ($\sim 10^{-7}$ atm.) and the probability of ionization, called the cross section S (in angstrom squared $\text{\AA}^2 = 10^{-20} \text{ m}^2$) is measured as a function of the colliding electron's energy, E , (measured in a unit called the electron volt, eV).



The impacting electron loses kinetic energy in the collision from $KE1$ to $KE2$ and the energy lost is required to both ionize the helium atom and give the liberated slow electron its kinetic energy of $KE3$. Helium ionizes at $E = 24.59$ eV and then S increases to a broad plateau at $E = 60\text{--}80$ eV after which S decreases slowly with E . There are good theoretical reasons for believing that our high energy data, beyond the plateau region, should fit the equation,

$$S(E) = A - A \exp\left(\frac{B}{E}\right)$$

Where A and B are unknown coefficients. From the data in Fig. 2.10 design a spreadsheet and use Solver to find the unknown coefficients and then plot the data with its NLSQ line. Using your equation what is the cross section for ionization of helium with 485 eV electrons and what is the precision of this cross-section?

Nido

Luxurious accommodation

Central zone 1 & 2 locations

Meet hundreds of international students

BOOK NOW and get a £100 voucher from voucherexpress

Nido Student Living - London

Visit www.NidoStudentLiving.com/Bookboon for more info.

+44 (0)20 3102 1060



	A	B
1	E/eV	$S/\text{\AA}^2$
2	150	0.43
3	175	0.40
4	200	0.39
5	250	0.37
6	300	0.34
7	350	0.31
8	400	0.28
9	450	0.27
10	500	0.26
11	550	0.24
12	600	0.23
13	650	0.21
14	700	0.21
15	750	0.19
16	800	0.19
17	850	0.17
18	900	0.17
19	950	0.17
20	1000	0.16

Figure 2.10: ionization cross sections for He.

[Jump to Solution 3 \(see page 47\)](#)

2.2.4 Question 4: Enzyme Reaction Kinetics

The rates of enzyme reactions literally determine our health and well-being, it is extremely important both personally and industrially (the pharmaceutical industry). Adenosine triphosphate (ATP) is used by all cell to transfer energy which is accessed by hydrolysis with myosin. Fig. 2.11 shows the molecule ATP.

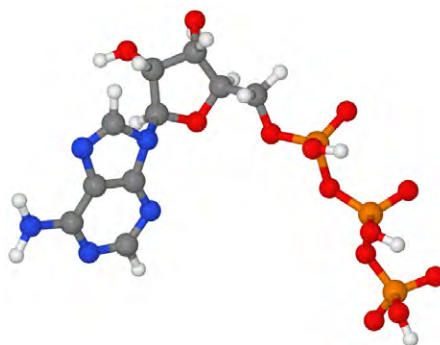

Figure 2.11: ATP N = blue, C = dark grey, H = grey, P = orange, O = red.

For a constant enzyme concentration, the rates of many enzyme reactions follow the Michaelis-Menten equation,

$$v = \frac{v_{\max} [S]}{K_M + [S]}$$

where v is the rate of reaction and $[S]$ is the substrate molecules concentration, for this reaction the substrate is ATP. K_M is the Michaelis constant, characteristic of the enzyme and substrate combination.

At large concentrations of substrate when $[S] \gg K_M$ then the denominator ($K_M + [S]$) $\approx [S]$ and so the rate plateaus off to $v \approx v_{\max}$. When $v = v_{\max}/2$ then $K_M = [S]_{1/2}$ with $[S]_{1/2}$ being the substrate concentration corresponding to $v_{\max}/2$. The Michaelis-Menten equation is a nonlinear equation but may be rearranged into a double reciprocal form called the Lineweaver-Burk equation.

$$\frac{1}{v} = \frac{1}{v_{\max}} + \frac{K_M}{v_M [S]}$$

Plotting $1/v$ against $1/[S]$ gives a straight line graph called the Lineweaver-Burk plot. This transformed linear equation is very useful in distinguishing different types of enzyme inhibition. However, transforming the equation into a linear form distorts the structure of the data and the relative errors as it is strongly biased in fitting the data at low values of $[S]$ and low v which are the *least* precise part of the data set with the largest relative error, it is inferior to a NLLSQ fitting. Fig. 2.12 is the data obtained by a student using a constant myosin enzyme concentration for the hydrolysis of ATP at 25°C and pH = 7.0. The $[ATP]/10^{-5}$ mol L⁻¹ and $v/10^{-6}$ mol L⁻¹ s⁻¹ however they are shown as $[ATP]$ and v for clarity in the spreadsheet.

	A	B
1	[ATP]	v
2	7.5	0.06
3	12.5	0.10
4	25	0.13
5	32.5	0.15
6	50	0.16
7	75	0.18
8	100	0.19
9	125	0.19
10	150	0.20
11	175	0.21
12	200	0.20
13	225	0.21
14	250	0.20
15	275	0.21
16	300	0.21
17	325	0.21
18	350	0.20

Figure 2.12: [ATP] and its rate of hydrolysis by myosin.

Plot the raw data as a Michaelis-Menten equation (v against $[S]$) and use the fact that the curve goes to v_{\max} at large $[S]$ and when $v = v_{\max}/2$ then $K_M = [S]_{1/2}$. Use these values to help with your starting values of the two constants. Solve the data by a NLLSQ fitting of the Michaelis-Menten equation and find a measure of the precision of the constants.

[Jump to Solution 4 \(see page 48\)](#)

2.3 Week 2 Tutorial Solutions

2.3.1 Solution 1: Boiling Points of n -Alkanes

	A	B	C	D	E	F	G
1	n	BP/K	BP_calc	R	SR		
2	5	309	309.034	-0.034	0.001	$A =$	724.533
3	6	342	341.949	0.051	0.003	$B =$	4.069
4	8	399	398.960	0.040	0.002	$C =$	384.741
5	10	447	447.209	-0.209	0.044		
6	11	469	468.815	0.185	0.034		
7	12	489	489.033	-0.033	0.001		
8							
9				$SSR =$	0.0842		

Figure 2.13: n -alkane boiling points for NLLSQ fitting.

SIMPLY CLEVER



**WE WILL TURN YOUR CV
INTO AN OPPORTUNITY
OF A LIFETIME**

Do you like cars? Would you like to be a part of a successful brand?
As a constructor at ŠKODA AUTO you will put great things in motion. Things that will ease everyday lives of people all around Send us your CV. We will give it an entirely new new dimension.

Send us your CV on
www.employerforlife.com

Fig. 2.13 shows the spreadsheet for using Solver, column C has the calculated boiling point using the model equation with C2 having the equation,

$$= \$G\$2 * \text{LOG}(A2 + \$G\$3) - \$G\$4$$

typed in the formula window. Cell D2 has $=B2 - C2$, and E2 has $=D2^2$ entered. The rests of the columns C, D and E are filled in by copying and pasting. The SSR is in cell E9 with $=\text{SUM}(E2:E7)$ entered.

We need to find a reasonable initial starting values for the arbitrary constants. If you type in unity (1) in G2, G3, G4 then the SSR is over a million and is clearly wrong. The boiling points are in the range of 300–400 K which arises very approximately as the difference between A and C. So typing in a few values by hand then $A = 700$ and $C = 300$ gives $\text{SSR} = 8234$, which is a lot smaller than a million. The constant B fine tunes the boiling point for changes in chain length of the alkane. So starting from $B = 1$ try some numbers and you find that $B = 2$ gives an $\text{SSR} = 765$. This should be a good enough starting point for the DEPS algorithm to find the global minimum.

Placing the cursor on cell E9 click on Tools, Solver. The target cell should be $\$E\9 , click on minimize, select cells G2 to G4 to change. In the Options of the Solver window make sure the algorithm used is DEPS, edit learning cycles from 2,000 to 2,000,000 and the stagnation limit from 70 to 70,000. Click on OK and then Solve. Stagnation is reached after 9.59 seconds on my laptop with the final results shown in Fig. 2.13 with $\text{SSR} = 0.0842$.

Now we have the global minimum for the model equation of the boiling points we need to manually vary each constant in turn and look for the changes in SSR of a factor of 10. Such an approach quickly gives us estimates of the precisions of the arbitrary constants, A is precise to ± 0.1 ; B to ± 0.01 ; and C to ± 0.1 . The NLLSQ fit of the model equation for the six n -alkanes is shown below and Fig. 2.14 shows the data and our fitted NLLSQ equation.

$$BP = (724.5 \pm 0.1 \text{ K}) \log(n + (4.07 \pm 0.01)) - (384.7 \pm 0.1 \text{ K})$$

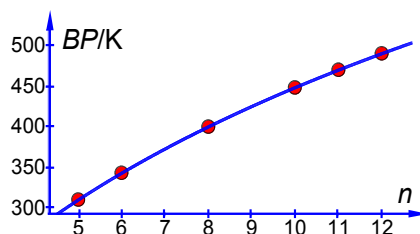

Figure 2.14: boiling points of n -alkanes.

The boiling point of *n*-nonane is interpolated from our NLLSQ equation as,

$$BP = (724.5 \pm 0.1 \text{ K}) \log(9 + (4.07 \pm 0.01)) - (384.7 \pm 0.1 \text{ K})$$

$$BP = (424.0 \uparrow 424.5 \downarrow 423.6) \text{K}$$

$$BP = 424.0 \pm 0.5 \text{ K}$$

Our NLLSQ equation may be used to interpolate the missing boiling points for $n = 7$ and $n = 9$ with a confidence of $\pm 0.5 \text{ K}$. However, *extrapolating* outside the range of n values for other alkanes is much less certain and should be treated with extreme caution.

[Return to Question 1 \(see page 38\)](#)

2.3.2 Solution 2: Heat Capacity of Solid Lead

The Solver spreadsheet for the Shomate equation is

	A	B	C	D	E	F	G
1	T / K	$t = T/1000$	$C(p)/\text{J K}^{-1} \text{ mol}^{-1}$	$C(p \text{ calc})$	SR		
2	300	0.30	26.7	26.71	0.00019	$A =$	26.839
3	350	0.35	27.3	27.26	0.00190	$B =$	2.028
4	400	0.40	27.7	27.72	0.00039	$C =$	4.000
5	450	0.45	28.1	28.15	0.00229	$D =$	0.916
6	500	0.50	28.6	28.56	0.00125	$E =$	-0.101
7	550	0.55	29.0	28.98	0.00026		
8	600	0.60	29.4	29.41	0.00019		
9							
10				$SSR =$	0.00647		

Figure 2.15: Shomate equation for solid Pb C_p NLLSQ fitting.

Column D has the calculated heat capacity with D2 having,

$$= \$G\$2 + (\$G\$3*B2) + (\$G\$4*(B2^2)) + (\$G\$5*(B2^3)) + \$G\$6/(B2^2)$$

which refers to the temperature in kelvin/1000 and the location of the five arbitrary constants to A to E . Cell E2 takes the residual and squares it, *i.e.* the E2 is $(C2-D2)^2$. The next question is the starting estimates for the constants, typing in unity into each of them gives $SSR = 3037$. Looking at the input data and the model equation then the heat capacities are in the 20s, so make $A = 20$ and typing in some values for B we find an initial value for the first temperature term $B = 5$. This gives $SSR = 63.4$ when the other arbitrary constants are unity, this is a good enough starting point for iterating to the global minimum.

With the cursor on the SSR click on Tools, Solver, and in the Solver window, minimize and select cells G2 to G6 to vary. Click on Options and make sure the solver engine is DEPS; edit the number of learning cycles (iterations) from 2,000 to 2,000,000 and increase the stagnation number from 70 to 70,000. It took 15.7 seconds and 1454 iterations to find the fit with $SSR = 0.00647$ which is a good fit, see Fig. 2.16. Finding a measure of the precision of the constants is carried out by changing the digits (and then undoing the change) systematically through the each constant until we find a change of about an order of magnitude in the SSR. This gives us a final Shomate equation which the final figure shown is the last significant digit. For clarity I have not included units in the equation. Fig. 2.16 shows a graph of the experimental data with our fitted line for the above Shomate equation.

$$C_p = (26.8 \pm 0.1) + (2.0 \pm 0.1)t + (4.0 \pm 0.1)t^2 + (0.9 \pm 0.5)t^3 - \frac{(0.10 \pm 0.01)}{t^2}$$



Develop the tools we need for Life Science Masters Degree in Bioinformatics

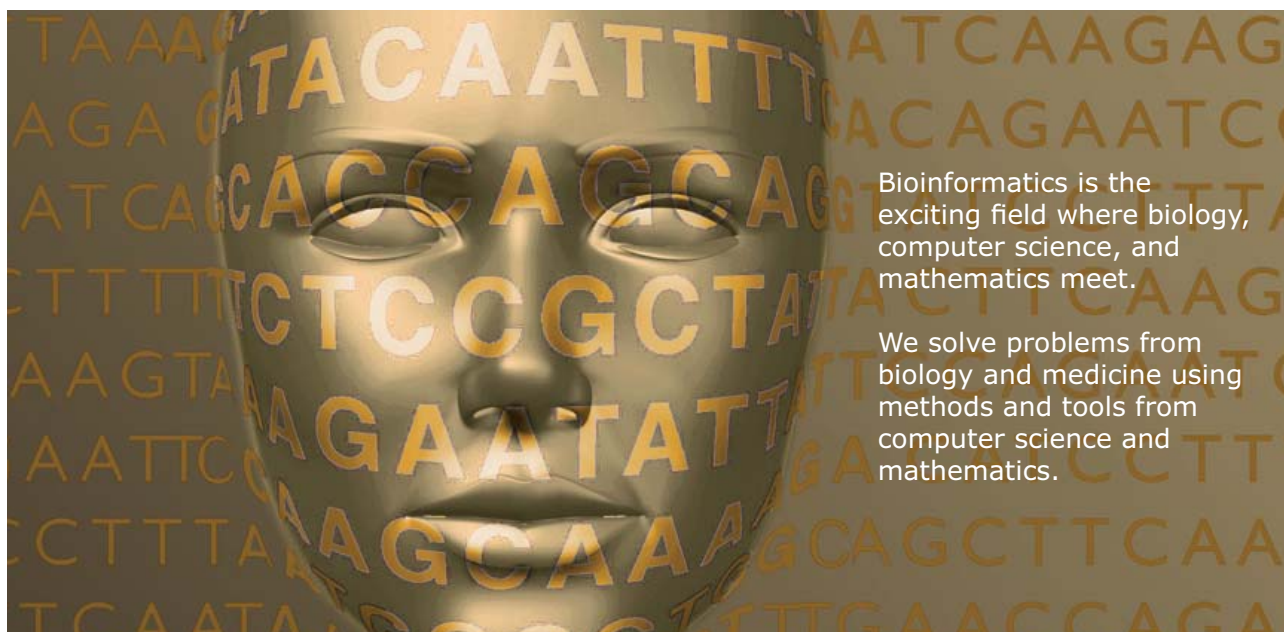

Bioinformatics is the exciting field where biology, computer science, and mathematics meet.

We solve problems from biology and medicine using methods and tools from computer science and mathematics.

Read more about this and our other international masters degree programmes at www.uu.se/master



Click on the ad to read more

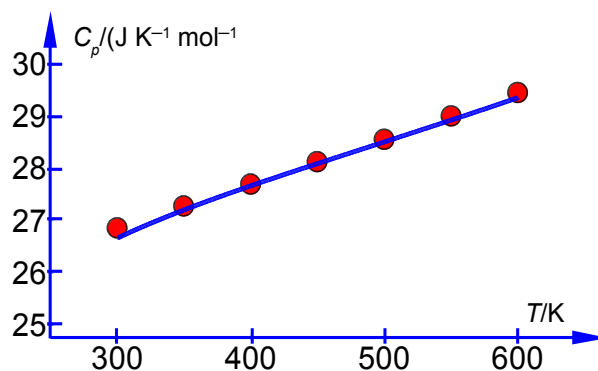

Figure 2.16: Shomate equation NLLSQ line for C_p of Pb.

[Return to Question 2 \(see page 39\)](#)

2.3.3 Solution 3: Ionization of He

Fig. 2.17 is the spreadsheet for the NLLSQ fitting of the ionization data for helium for our model equation.

	A	B	C	D	E	F
1	E/eV	$S/\text{\AA}^2$	$S(\text{calc})$	SR		
2	150	0.43	0.420136	0.000097	$A =$	0.446103
3	175	0.40	0.407121	0.000051	$B =$	426.554
4	200	0.39	0.393236	0.000010		
5	250	0.37	0.365113	0.000024		
6	300	0.34	0.338473	0.000002		
7	350	0.31	0.314232	0.000018		
8	400	0.28	0.292532	0.000157		
9	450	0.27	0.273214	0.000010		
10	500	0.26	0.256024	0.000016		
11	550	0.24	0.240695	0.000000		
12	600	0.23	0.226982	0.000009		
13	650	0.21	0.214665	0.000022		
14	700	0.21	0.203558	0.000041		
15	750	0.19	0.193502	0.000012		
16	800	0.19	0.184362	0.000032		
17	850	0.17	0.176022	0.000036		
18	900	0.17	0.168387	0.000003		
19	950	0.17	0.161372	0.000074		
20	1000	0.16	0.154907	0.000026		
21						
22			$SSR =$	0.000642		

Figure 2.17: ionization cross-sections for helium electroionization.

Column C is the calculated cross section S e.g. cell C2 is,

$$= (\$F\$2) - (\$F\$2 * \text{EXP}(-\$F\$3/A^2))$$

and the SR in D2 is $= (B2 - C2)^2$. The formulae from C2 and D2 are copied down to C20 and D20 with the appropriate variable for column A. The SSR in cell D22 is $= \text{SUM}(D2:D20)$.

The next important task is the initial guess for A and B . Entering the default $A = 1$ and $B = 1$ gives the sum of squares equals to 1.42. The first value for S is around 0.4 so A should be around 0.4. Trial and error by typing in various values for the constants with $A = 0.4$ and typing in B as 100, 200, 300, 400, 500 and 600 gives shows that $B = 500$ has $SSR = 0.004$ which is the smallest value. So the initial estimates are $A = 0.4$ and $B = 500$. Selecting DEPS and editing cycle limit to 2,000,000 and stagnation limit 70,000. Solver reaches stagnation after 17 seconds with 1096 iterations and $SSR = 6.42 \times 10^{-4}$.

Altering the digits of each constant looking for changes of an order of magnitude in SSR gives the following model equation. The NLLSQ equation is shown below with the last *significant* figure shown $A = 0.45 \pm 0.01 \text{ \AA}^2$ and with $B = 430 \pm 20 \text{ eV}$. Fig. 2.18 shows a graph of the experimental data with our fitted equation.

$$S(E) = (0.45 \text{ \AA}^2) - (0.45 \text{ \AA}^2) \exp\left(-\frac{430 \text{ V}}{E \text{ eV}}\right)$$

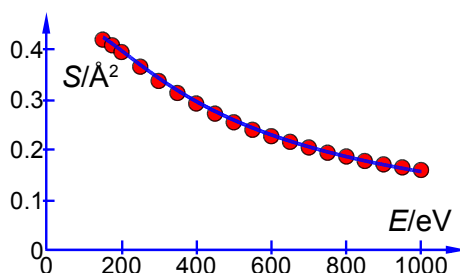

Figure 2.18: helium electroionization cross-section with NLLSQ curve.

[Return to Question 1 \(see page 39\)](#)

2.3.4 Solution 4: Enzyme Reaction Kinetics

In Fig. 2.19 the enzyme catalyzed data are plotted, along with a curve which is $v = 0.21[S]/(18 + [S])$ with the estimated constants obtained by “eye” but nevertheless the curve is a reasonable initial fit to the data.

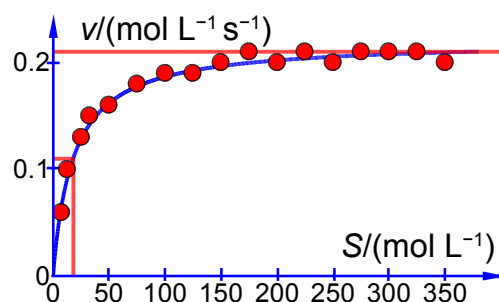

Figure 2.19: approximate curve for Michaelis-Menten equation.

Thus the initial guesses are $v_{\max} = 0.21 \text{ mol L}^{-1} \text{ s}^{-1}$ and $K_M = 18 \text{ mol L}^{-1}$ and the NLLSQ solved spreadsheet is shown in Fig. 2.20.

UNIVERSITY OF COPENHAGEN



Copenhagen Master of Excellence

Copenhagen Master of Excellence are two-year master degrees taught in English at one of Europe's leading universities

Come to Copenhagen - *and aspire!*

Apply now at
www.come.ku.dk



cultural studies

religious studies

science

	A	B	C	D	E	F
1	[ATP]	v	v_{calc}	SR		
2	7.5	0.06	0.068014	0.000064	$v_{\text{max}} =$	0.219857
3	12.5	0.10	0.093976	0.000036	$K_M =$	16.743864
4	25	0.13	0.131670	0.000003		
5	32.5	0.15	0.145102	0.000024		
6	50	0.16	0.164702	0.000022		
7	75	0.18	0.179732	0.000000		
8	100	0.19	0.188324	0.000003		
9	125	0.19	0.193886	0.000015		
10	150	0.20	0.197780	0.000005		
11	175	0.21	0.200658	0.000087		
12	200	0.20	0.202873	0.000008		
13	225	0.21	0.204629	0.000029		
14	250	0.20	0.206057	0.000037		
15	275	0.21	0.207239	0.000008		
16	300	0.21	0.208235	0.000003		
17	325	0.21	0.209085	0.000001		
18	350	0.20	0.209820	0.000096		
19						
20			$SSR =$	0.000441		

Figure 2.20: Michaelis-Menten equation NLLSQ fit of APT-myosin data.

The worth of the approximate graph of the data is shown when the v_{max} and K_M are made unity the SSR is 10.95. However, when are estimates from the Fig. 2.19 are typed in ($v_{\text{max}} = 0.21$ and $K_M = 18$) then $SSR = 0.0021$. Using the DEPS algorithm and editing the cycle limit to 2,000,000 and stagnation limit to 70,000 Solver reaches stagnation after 14.7 seconds with 1088 iterations and $SSR = 0.000441$.

Manually altering the maximum rate of reaction v_{max} and Michaelis constant K_M each one by one digit at a time (and undoing the changes) we look for the last significant figure (defined as altering the sum of squares of the residuals by about an order of magnitude). The two constants are then found to be,

$$v_{\text{max}} = (0.22 \pm 0.01 \text{ mol L}^{-1} \text{ s}^{-1}) \text{ and } K_M = (17 \pm 4 \text{ mol L}^{-1})$$

and the Michaelis-Menten Equation is below with the last significant figures shown,

$$v = \frac{(0.22 \text{ mol L}^{-1} \text{ s}^{-1}) [\text{S mol L}^{-1}]}{(17 \text{ mol L}^{-1}) + [\text{S mol L}^{-1}]}$$

The NLLSQ fitted plot is in Fig. 2.21.

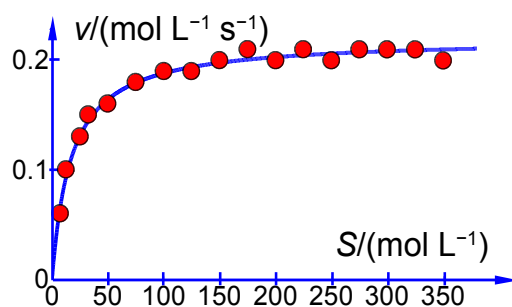

Figure 2.21: NLLSQ curve for Michaelis-Menten equation.

Clearly with the linear and non-linear methods of curve fitting we have covered in Weeks 1 and 2 you can now tackle *any model equation* and experimental data in the future, including when you are doing research.

[Return to Question 2 \(see page 41\)](#)

Brain power

By 2020, wind could provide one-tenth of our planet's electricity needs. Already today, SKF's innovative know-how is crucial to running a large proportion of the world's wind turbines.

Up to 25 % of the generating costs relate to maintenance. These can be reduced dramatically thanks to our systems for on-line condition monitoring and automatic lubrication. We help make it more economical to create cleaner, cheaper energy out of thin air.

By sharing our experience, expertise, and creativity, industries can boost performance beyond expectations. Therefore we need the best employees who can meet this challenge!

The Power of Knowledge Engineering

Plug into The Power of Knowledge Engineering.
Visit us at www.skf.com/knowledge

3 Week 3: Chemistry and Complex Numbers

3.1 Why use Imaginary Numbers and Complex Numbers?

I am giving a longer than normal introduction to imaginary and complex numbers because as a student I couldn't see why some lecturers and professors wanted to use complex numbers instead of tangents, sines and cosines which I knew from school and also because the explanations in Maths books are not always very helpful. I want to show you why they are so useful, they cut down the use of a calculator and reduce the use of trig relationships. I want to start by comparing imaginary numbers with their close neighbours, the negative numbers. Negative numbers give you a "mirror image" of the positive number on the other side of zero on the number line, thus positive and negative numbers are all one-dimensional. Multiplying x by -1 "flips" you along the number line to $-x$.

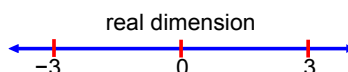

Figure 3.1: the positive and negative real number line.

For example in words, "I owe the bank £1000 and after doing some evening work I earn £50 and then pay the bank £50, then I now owe the bank £950". A better, and more elegant way of handling the situation is to use positive and negative numbers and Maths which keep track of the direction along the number line automatically my *money* = $-\text{£}1000 + \text{£}50 = -\text{£}950$. You shouldn't be too smug about the use of negative numbers (don't say "I know all this, so why bother", well be patient). Negative numbers were not understood and were considered absurd by many great Mathematicians until the 1700s then they only came into normal usage driven partly by their short elegant way of summarizing things from book keeping to Chemical Analysis.

Imaginary numbers have a similar history to negative numbers, in that people didn't or still don't think they are "real" (pun intended). We can solve for x for equations such as $x^2 = 25$ easily, but what does the solution for $x^2 = -25$ mean? Although they may appear strange to us, they are no more strange than zero, negative, fractional and irrational numbers (which can't be written as a simple fraction) appeared to scientists before us when they were first introduced. Let us assume the imaginary number i exists, where

$$i = (-1)^{1/2}$$

As i is just a number (like e and π) it is written in upright roman text. If i exists then Maths becomes easier and new relationships emerge that are easily described. I dislike the term “imaginary number” it was introduced when i was discovered around 1545 by the first group of scientists who thought they were nonsense and absurd. The number i is just as normal as other numbers but the name “imaginary” stuck for purely historical reasons and the terms “real” and “imaginary” are just labels.

3.1.1 Visual Understanding of Negative and Complex Numbers

The equation $x^2 = 25$ really means “what operation on x , when *applied twice*, turns 1 to 25”, *i.e.*

$$1 \times x^2 = 25$$

The two answers are $x = 5$ and $x = -5$, *i.e.* you can “scale 1 by 5” or “scale 1 by 5 and then flip” and do either of these operations twice over, where “flipping” or taking the opposite is multiplying by a negative. We are still dealing with the one-dimensional real number line.

What about the imaginary number $x^2 = -1$?

$$1 \times x^2 = -1$$

“What operation on x , when you apply *twice* will turn 1 into -1 ”? It cannot be multiplying by a positive twice because the result remains positive. It cannot be multiplying by a negative twice as the first negative multiplication flips x to negative but the second one flips it again to give a positive number. So the operation we are looking for cannot be just on the real number line of positive and negative numbers (labelled “Re”).

We need to add a second dimension (labelled “Im”) at right angles to the real number line for imaginary numbers which crosses at the origin (0,0), Fig. 3.2. We are now dealing with two-dimensional number space called the complex plane and Fig. 3.2 is an example of an Argand diagram named after Jean-Robert Argand (1813) who first popularized the idea of visualizing imaginary numbers in terms of a graph although people had tried to understand complex numbers from around 1545 onwards.

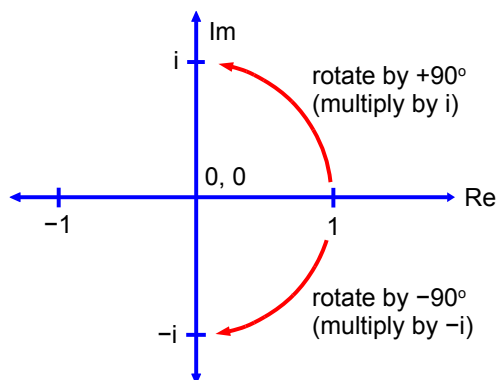

Figure 3.2: Argand diagram.

So returning to “what operation on x , when you apply twice will turn 1 into -1 ”, the operation we are looking for is *anticlockwise* rotation of 1 by 90° takes x onto the imaginary line at i and then another anticlockwise rotation of i by 90° takes i to -1 . Alternatively, we could rotate twice in the *clockwise* direction to turn 1 into $-i$ and another clockwise rotation turns $-i$ into -1 . So there are *two* square roots of -1 , they are i and $-i$.

$$x = (-1)^{1/2} = \pm i$$

Trust and responsibility

NNE and Pharmaplan have joined forces to create NNE Pharmaplan, the world’s leading engineering and consultancy company focused entirely on the pharma and biotech industries.

Inés Aréizaga Esteva (Spain), 25 years old
Education: Chemical Engineer

– You have to be proactive and open-minded as a newcomer and make it clear to your colleagues what you are able to cope. The pharmaceutical field is new to me. But busy as they are, most of my colleagues find the time to teach me, and they also trust me. Even though it was a bit hard at first, I can feel over time that I am beginning to be taken seriously and that my contribution is appreciated.

NNE Pharmaplan is the world’s leading engineering and consultancy company focused entirely on the pharma and biotech industries. We employ more than 1500 people worldwide and offer global reach and local knowledge along with our all-encompassing list of services.
nnepharmaplan.com

nne pharmaplan®



3.1.2 Patterns of Numbers

For negative numbers, if we repetitively multiply x by -1 we get the pattern below,

$$x, -x, x, -x, x, \dots$$

because -1 does not change the size of a number only its sign we just flip back and forth along the real axis. So negative numbers model things which flips back and forward (oscillate) between two situations.

For imaginary numbers, if we repetitively multiply by i we get the pattern below,

$$x, ix, -x, -ix, x, \dots$$

this is easy to visualize as rotations on an Argand diagram, Fig. 3.3. We have completed a 360° cycle after every fourth rotation.

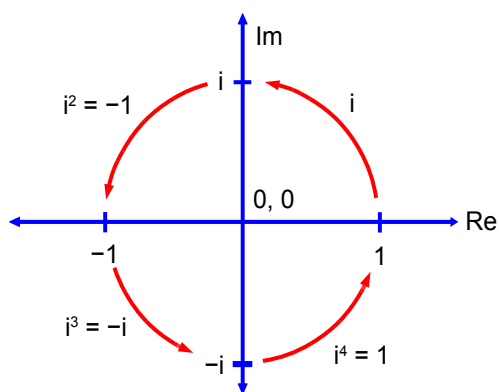

Figure 3.3: multiple rotations by i .

So although negative numbers model oscillations along the real axis, imaginary numbers model *rotations* in two-dimensions *i.e.* anything with a *cyclic* or a *rational* motion. So wave motions as in wavefunctions are ideal candidates as well as other cyclic processes that Chemists have to deal with. But why not use \tan , \cos , \sin instead?. The answer is it is easier, less calculator work, less pure memory work of trig relationships, we cover this aspect now.

3.1.3 Complex Numbers

A number may be both “real” and “imaginary” and we call it a complex number. We may rotate by *any* angle not just 90° . So if we rotate a number x by any arbitrary angle θ other than 90° , the result would have both real and imaginary parts and be a complex number which is written as

$$z = a + ib$$

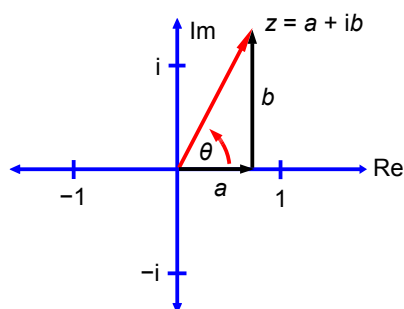

Figure 3.4: rotation by an arbitrary angle.

Where a and b are both real numbers, but ib is the imaginary part of z and a is the real part. The components a and b may be either positive or negative, *i.e.* the complex number may be in any of the four quadrants of the Argand diagram. At first the idea that a single number has two parts is a bit strange but you have been doing something similar for years. What does the decimal 10.7 mean? It consists of two parts, an integer and a fraction and so $10.7 = 10 + 7/10$, *i.e.* one number consisting of two parts. The angle θ is called the argument, $\arg(z)$ and is the angle of the complex number measured from the real axis, with *anticlockwise* rotation defined as a *positive* angle. The word “complex” just means “a mixture” when used to describe numbers.

3.1.4 Size of a Complex Number

The size or magnitude of a negative number, $-x$, is its absolute distance from zero (called the modulus) and written as $|x|$.

$$|x| = \sqrt{-x^2}$$

The size of a complex number, its modulus $|z|$, is the absolute distance from zero which we can obtain using Pythagoras’s theorem in Fig. 3.4 and is the absolute length of the *red* line.

$$|z| = \sqrt{a^2 + b^2}$$

3.1.5 Forms of a Complex Number

$$z = a + ib \quad \text{Standard Form}$$

The above is the *standard form*. From Fig. 3.4 we have $a = |z| \cos(\theta)$ and $b = |z| \sin(\theta)$ which gives the polar form below, where θ may be in degrees or radians.

$$z = |z| (\cos \theta + i \sin \theta) \quad \text{Polar form}$$

From the definition of an exponential as a power series and then replacing x by $i\theta$ we obtain,

$$\begin{aligned}\exp(x) &= 1 + x + \frac{x^2}{2!} + \frac{x^3}{3!} + \frac{x^4}{4!} + \frac{x^5}{5!} \\ \exp(i\theta) &= 1 + (i\theta) + \frac{(i\theta)^2}{2!} + \frac{(i\theta)^3}{3!} + \frac{(i\theta)^4}{4!} + \frac{(i\theta)^5}{5!} \\ \exp(i\theta) &= \left(1 - \frac{\theta^2}{2!} + \frac{\theta^4}{4!} - \dots\right) + i\left(\theta - \frac{\theta^3}{3!} + \frac{\theta^5}{5!} - \dots\right)\end{aligned}$$

from the series expansions for sin and cos we have Euler's formulae for positive and negative exponents and which then gives the exponential form of a complex number. Where θ must be in *radians* so that $i\theta$ of the exponential is dimensionless.

$$\exp(i\theta) = \cos\theta + i\sin\theta \quad \exp(-i\theta) = \cos\theta - i\sin\theta \quad \text{Euler's Formulae}$$

$$z = |z| \exp(i\theta) \quad \text{Exponential form}$$

From Euler's formula (1748) we can get the log version of a complex number. But the important thing is there is very *little* memory work (probably best to remember Euler's formulae) if we use the geometric approach of the Argand diagram which allows easy conversion between the various forms.

$$i\theta = \ln(\cos\theta + i\sin\theta) \quad \text{Logarithmic Form}$$

This e-book
is made with
SetaPDF





SETASIGN

PDF components for PHP developers

www.setasign.com



3.1.6 Complex Addition

Addition of real numbers may be thought of as “sliding” along the real number axis. Addition with complex numbers is similar, but we “slide” in two dimensions simultaneously but separately (we add the real and imaginary components *separately*). For z_1 and z_2 shown below then the sum z_3 is,

$$z_1 = (2 + i4) \quad z_2 = (-3 + i2)$$

$$z_3 = (2 + i4) + (-3 + i2) = (-1 + i6)$$

This is easier to understand from the Argand diagram (Fig. 3.5) which shows the “sliding” in the two dimensions with z_1 , z_2 , z_3 coloured (black, red, and dashed green for clarity).

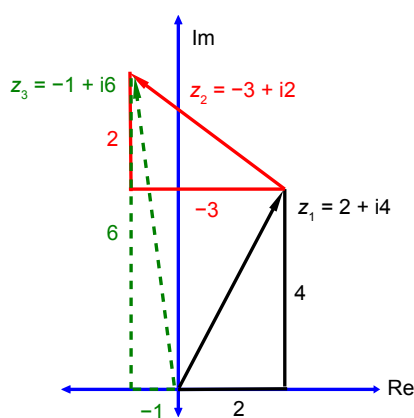

Figure 3.5: complex addition.

3.1.7 Complex Subtraction

The process of subtraction is the “opposite” or reverse process to addition. As before, for z_1 and z_2 , then the difference z_3 is equal to,

$$z_1 = (2 + i4) \quad z_2 = (-3 + i2)$$

$$z_3 = (2 + i4) - (-3 + i2) = (2 + i4) + (3 - i2) = (5 + i2)$$

In the Argand diagram, we draw z_1 and the *negative* of z_2 (where $-z_2$ has the same magnitude as z_2 but the real and imaginary parts change sign and so the angle is at 180° to the original z_2). We then add z_1 and $-z_2$ following the normal rules for adding the two components, see Fig. 3.6.

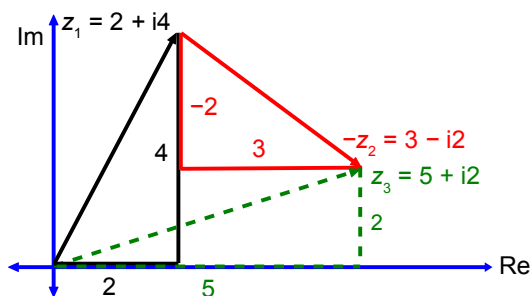

Figure 3.6: complex subtraction.

3.1.8 Complex Multiplication

Multiplication and division are the “opposites” or reverse operations of one another. So starting with multiplication it is simply multiplying the two complex numbers using the normal rules of algebra for multiplying out a pair of brackets, as below.

$$z_1 = (2 + i4) \quad z_2 = (-3 + i2)$$

$$z_3 = (2 + i4)(-3 + i2) = -6 + i4 - i12 + i^2 8$$

$$z_3 = -14 - i8$$

$$\theta_3 = \tan^{-1}\left(\frac{8}{14}\right) = 29.7^\circ$$

The complex multiplication above is actually carrying out the following two operations,

Complex Multiplication: multiply the sizes and add the angles $ z_3 = z_1 \times z_2 $ $\theta_3 = \theta_1 + \theta_2$
--

Also notice that we really multiply the sizes when we multiply real numbers, $3 \times 4 = |3| \times |4| = 12$ and also with negative numbers, $-3 \times 4 = -(3 \times 4) = -(|3| \times |4|) = -12$. As before, for z_1 and z_2 as given preciously,

$$|z_1| = \sqrt{2^2 + 4^2} = \sqrt{20} \quad |z_2| = \sqrt{-3^2 + 2^2} = \sqrt{13}$$

$$|z_3| = \sqrt{20} \times \sqrt{13} = 16.1$$

This agrees with the size from $z_3 = \sqrt{(14^2 + 8^2)} = 16.1245$ for our straight multiplication. The angle is the sum of the angles,

$$\theta_3 = \tan^{-1}\left(\frac{4}{2}\right) + \tan^{-1}\left(\frac{2}{-3}\right) = 63.4^\circ + (-33.7^\circ) = 29.7^\circ$$

In the Argand diagram, Fig. 3.7, $z_1 = (2 + i2)$ is in the first quadrant; $z_2 = (-3 + i2)$ is in the second quadrant and the angle θ_2 is negative (clockwise) from the real axis. The resultant $z_3 = (-14 - i8)$, not shown in full for clarity, is in the third quadrant and the angle θ_3 is positive (anticlockwise) from the real axis.

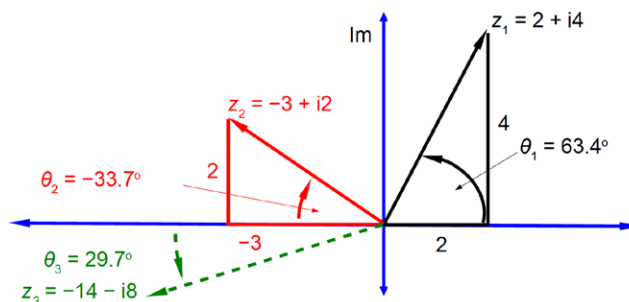

Figure 3.7: complex multiplication.

3.1.9 Complex Division

Multiplication and division are the “opposites” or reverse operations of one another.

Complex Division: divide the sizes and subtract the angles

$$|z_3| = \frac{|z_1|}{|z_2|} \quad \theta_3 = \theta_1 - \theta_2$$



Sharp Minds - Bright Ideas!

Employees at FOSS Analytical A/S are living proof of the company value - First - using new inventions to make dedicated solutions for our customers. With sharp minds and cross functional teamwork, we constantly strive to develop new unique products - Would you like to join our team?

FOSS works diligently with innovation and development as basis for its growth. It is reflected in the fact that more than 200 of the 1200 employees in FOSS work with Research & Development in Scandinavia and USA. Engineers at FOSS work in production, development and marketing, within a wide range of different fields, i.e. Chemistry, Electronics, Mechanics, Software, Optics, Microbiology, Chemometrics.

We offer
A challenging job in an international and innovative company that is leading in its field. You will get the opportunity to work with the most advanced technology together with highly skilled colleagues.

Read more about FOSS at www.foss.dk - or go directly to our student site www.foss.dk/sharpminds where you can learn more about your possibilities of working together with us on projects, your thesis etc.

Dedicated Analytical Solutions

FOSS
 Slangerupgade 69
 3400 Hillerød
 Tel. +45 70103370
www.foss.dk

The Family owned FOSS group is the world leader as supplier of dedicated, high-tech analytical solutions which measure and control the quality and production of agricultural, food, pharmaceutical and chemical products. Main activities are initiated from Denmark, Sweden and USA with headquarters domiciled in Hillerød, DK. The products are marketed globally by 23 sales companies and an extensive net of distributors. In line with the corevalue to be 'First', the company intends to expand its market position.



How do we subtract the angle? We use the complex conjugate z^* which has the same real component but the imaginary component is the mirror image (the real axis acting as the “mirror”) as in Fig. 3.8.

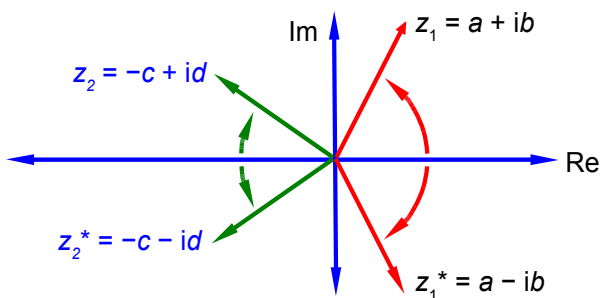

Figure 3.8: complex conjugates for two examples.

So multiplying by the complex conjugate is the same as subtracting the angle. So far we are at the stage of,

$$\frac{z_1 z_2^*}{z_2}$$

which has subtracted the angle all right, but at the same time it has altered the size of the numerator! So in order to correct this size change in the numerator we must alter the size of the denominator by the same amount,

$$z_3 = \frac{z_1 z_2^*}{z_2 z_2^*}$$

For the division of,

$$z_1 = (2 + i4) \quad z_2 = (-3 + i2)$$

$$z_3 = \frac{(2 + i4)(-3 - i2)}{(-3 + i2)(-3 - i2)} = \frac{-6 - i4 - i12 - i^2 8}{9 + i6 - i6 - i^2 4} = \frac{2 - i16}{9 + 4} = \frac{2}{13} - i \frac{16}{13}$$

$$z_3 = 0.1538 - i1.2308$$

Which gives the resultant angle (argument) of,

$$\theta_3 = \tan^{-1}\left(\frac{-1.2308}{0.1538}\right) = -82.9^\circ$$

z_3 has a positive real part and a negative imaginary part so it is in the fourth quadrant and the angle is clockwise (negative) from the real axis. This is clearer from the Argand diagram Fig. 3.9, z_3 is not shown in full for clarity.

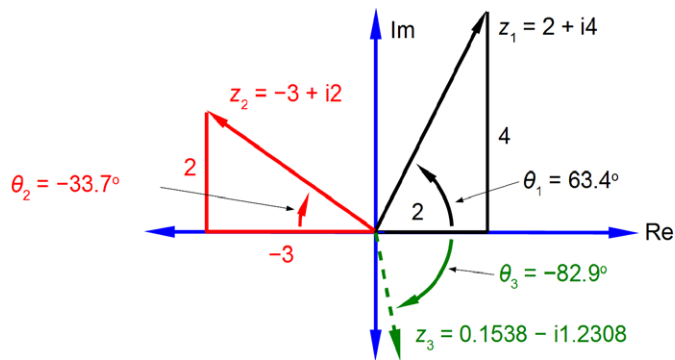

Figure 3.9: complex division.

3.1.10 de Moivre’s Formula

Multiplying the polar form of the complex number,

$$z = |z| (\cos \theta + i \sin \theta)$$

by itself n times then we multiply the size $|z|$ by itself n times, giving the final size $|z|^n$. We add the angle θ to θ , n times, giving the final angle $n\theta$. The resultant polar form is called de Moivre’s formula (also known as de Moivre’s theorem),

$$z^n = |z|^n (\cos n\theta + i \sin n\theta)$$

where n may be positive, negative, integer, or fractional, although if n is fractional then the result is multi-valued. I will give the two most common examples of the use of de Moivre’s theorem, the square root and the cube roots of a complex number,

$$z = 4 (\cos 60^\circ + i \sin 60^\circ)$$

As z is identical for 60° and 60° plus one revolution *i.e.* for $60^\circ + 360^\circ = 420^\circ$, we have,

$$z^{1/2} = 4^{1/2} \left(\cos \frac{60^\circ}{2} + i \sin \frac{60^\circ}{2} \right) \quad \text{and} \quad z^{1/2} = 4^{1/2} \left(\cos \frac{420^\circ}{2} + i \sin \frac{420^\circ}{2} \right)$$

$$z^{1/2} = 2 (\cos 30^\circ + i \sin 30^\circ) \quad \text{and} \quad z^{1/2} = 2 (\cos 210^\circ + i \sin 210^\circ)$$

There are two square roots of a complex number separated by 180° , *i.e.* $360^\circ/2$, as in Fig. 3.10. All you need to do is find the first root (the principal root) and then add another root at 180° to the first square root.

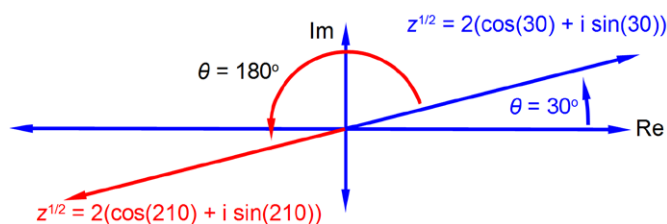

Figure 3.10: square root of a complex number.

The second example of the n being fractional is the cube root of,

$$z = 27(\cos 120^\circ + i \sin 120^\circ)$$

As z is identical for 120° and 120° plus either one or two revolutions *i.e.* ($120^\circ + 360^\circ = 480^\circ$) and ($120^\circ + 360^\circ + 360^\circ = 840^\circ$) we have,

$$z^{1/3} = 27^{1/3} \left(\cos \frac{120}{3} + i \sin \frac{120}{3} \right) \quad z^{1/3} = 27^{1/3} \left(\cos \frac{480^\circ}{3} + i \sin \frac{480^\circ}{3} \right)$$

$$z^{1/3} = 27^{1/3} \left(\cos \frac{840^\circ}{3} + i \sin \frac{840^\circ}{3} \right)$$

“I studied English for 16 years but...
...I finally learned to speak it in just six lessons”
Jane, Chinese architect

ENGLISH OUT THERE

Click to hear me talking before and after my unique course download



$$z^{1/3} = 3(\cos 40^\circ + i \sin 40^\circ) \quad z^{1/3} = 3(\cos 160^\circ + i \sin 160^\circ) \quad z^{1/3} = 3(\cos 280^\circ + i \sin 280^\circ)$$

There are three cube roots of a complex number each separated by 120° , *i.e.* $360^\circ/3$, as in Fig. 3.11. All you need to do is find the first root and then add 120° twice for the other two cube roots.

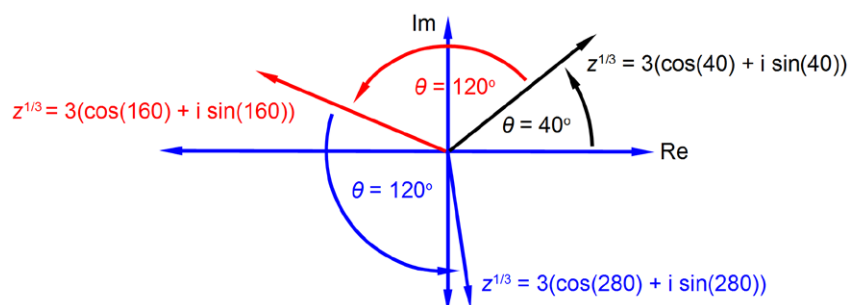

Figure 3.11: cube root of a complex number.

3.2 Week 3 Tutorial Questions

3.2.1 Question 1: Quantum Chemistry

In the quantum mechanics of electrons, atoms, molecules, or ions; chemists make use of wavefunctions (ψ). The reason is that the value of the wavefunction often varies in a cyclic fashion and so can very naturally be expressed as a complex number. If the wavefunction ψ has the value

$$\psi = A + iB$$

the probability of the system having that value of ψ is related to the product of the complex conjugate ψ^* and the wavefunction itself $\psi^* \psi$. Find whether the probability of the system is a real number?

[Jump to Solution 1 \(see page 66\)](#)

3.2.2 Question 2: Atomic Orbitals

The wavefunctions for the $2p_x$ and $2p_y$ atomic orbitals for the H-atom can be written as,

$$\psi_{2p_x} = A \exp\left(-\frac{r}{2a_0}\right) r \sin \theta \exp(i\varphi) \quad \psi_{2p_y} = A \exp\left(-\frac{r}{2a_0}\right) r \sin \theta \exp(-i\varphi)$$

Notice that the $2p_x$ and $2p_y$ atomic orbitals *only* differ in the sign of the complex number term for the phi exponential. Fig. 3.12 shows the polar coordinates (r, θ, φ) where r is the radial distance from the origin at the centre of a sphere; θ (theta) varies from 0 at the “north pole” to π radians at the “south pole”; and φ (phi) varies around the “equator” from 0 to 2π radians.

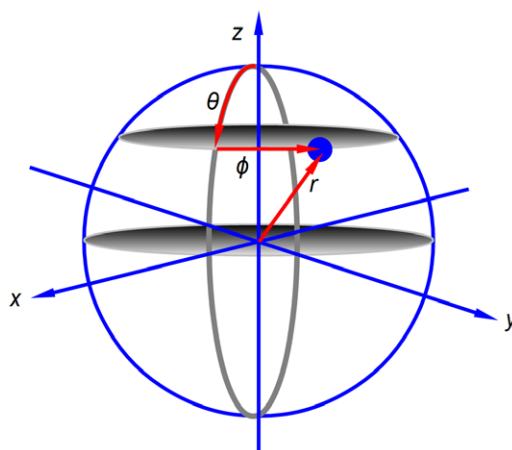

Figure 3.12: polar coordinate system.

Rewrite the sum of the two wavefunctions for $2p_x$ and $2p_y$ atomic orbitals for the H-atom as a real number.

[Jump to Solution 2 \(see page 67\)](#)

3.2.3 Question 3: Chemical Bond Vibrations

Chemists use infra red spectroscopy (IR) which relies on the vibrations of chemical bonds to identify particular “functional groups” in an organic or inorganic compound and as a method of identifying unknown molecules. Fig. 3.13 shows the bond stretching and shortening in a diatomic molecule’s bond length with time from a fully compressed distance, through the equilibrium (lowest energy) distance, to the fully extended bond distance and then all the way back again.

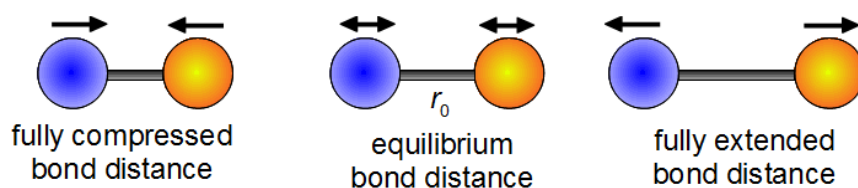

Figure 3.13: simple harmonic vibration of a chemical bond.

The theory behind this important spectroscopic technique makes use of a simple mathematical model to describe the vibration of a chemical bond which is called simple harmonic motion (SHM). The length of a chemical bond undergoing SHM can be described by the following equation.

$$r(t) = r_e + A \cos(k \omega t) + B \sin(k \omega t)$$

Where t is time; ω is the angular frequency in radians per second of the vibration with $\omega = 2\pi\nu$ where ν is the ordinary frequency in hertz (s^{-1}); A and B are arbitrary constants; r_e is the equilibrium bond distance; and k is the force constant or “stiffness” of the chemical bond.

The periodic motion of the atoms in a vibration are more naturally modelled using complex numbers rather than trig functions as the bond length varies in a cyclic fashion with time. Write down an alternative expression for this SHM equation in term of a complex exp ($ik\omega t$) and its complex conjugate.

[Jump to Solution 3 \(see page 68\)](#)

3.3 Week 3 Tutorial Solutions

3.3.1 Solution 1: Quantum Chemistry

Multiplying the wavefunction by its complex conjugate is easily done with basic complex number maths.

$$\psi = A + iB$$

$$\psi^* \psi = (A - iB)(A + iB) = A^2 + iAB - iBA - i^2 B^2$$

$$\psi^* \psi = A^2 + B^2$$

The Wake
the only emission we want to leave behind

Low-speed Engines Medium-speed Engines Turbochargers Propellers Propulsion Packages PrimeServ

The design of eco-friendly marine power and propulsion solutions is crucial for MAN Diesel & Turbo. Power competencies are offered with the world's largest engine programme – having outputs spanning from 450 to 87,220 kW per engine. Get up front! Find out more at www.mandieselturbo.com

Engineering the Future – since 1758.
MAN Diesel & Turbo



Click on the ad to read more

The product of $\psi^* \psi$ is always real and always positive (≥ 0), *i.e.* a wavefunction probability at a given point in space will be a real positive number, as it should be if the concept of probability is to make sense. Fig. 3.14 shows the wavefunction (red) for the $n = 2$ quantum level of the particle in a 1-dimensional box is both a negative and positive complex number where the green line is the zero level for both ψ_2 and ψ_2^* . The probability of the particle being at a certain position (blue) in the box is a positive real number.

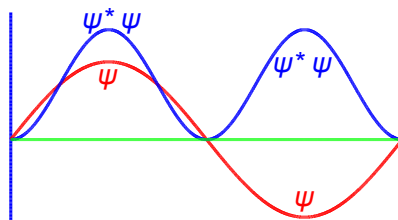

Figure 3.14: ψ_2 and $\psi_2^* \psi_2$ for a particle in a 1-dimensional box.

[Return to Question 1 \(see page 64\)](#)

3.3.2 Solution 2: Atomic Orbitals

The wavefunctions for the $2p_x$ and $2p_y$ atomic orbitals for the H-atom can be written as,

$$\psi_{2p_x} = A \exp\left(-\frac{r}{2a_0}\right) r \sin \theta \exp(i\varphi) \quad \psi_{2p_y} = A \exp\left(-\frac{r}{2a_0}\right) r \sin \theta \exp(-i\varphi)$$

To rewrite these as purely real numbers we make use of Euler's formulae written in terms of $i\varphi$,

$$\exp(i\varphi) = \cos \varphi + i \sin \varphi \quad \text{and} \quad \exp(-i\varphi) = \cos \varphi - i \sin \varphi$$

Adding our two wavefunctions,

$$\psi_{2p_x} + \psi_{2p_y} = A \exp\left(-\frac{r}{2a_0}\right) r \sin \theta (\exp(i\varphi) + \exp(-i\varphi))$$

Substituting using Euler's formulae gives the sum of the $2p_x$ and $2p_y$ atomic orbitals for the hydrogen atom which is a real function.

$$\psi_{2p_x} + \psi_{2p_y} = A \exp\left(-\frac{r}{2a_0}\right) r \sin \theta (\cos \varphi + i \sin \varphi + \cos \varphi - i \sin \varphi)$$

$$\psi_{2p_x} + \psi_{2p_y} = 2A \exp\left(-\frac{r}{2a_0}\right) r \sin \theta \cos \varphi$$

In quantum chemistry, it is often more convenient to use complex-functions, particularly when one needs to apply quantum mechanical operators to a wavefunction to generate a new wavefunction.

[Return to Question 2 \(see page 64\)](#)

3.3.3 Solution 3: Chemical Bond Vibrations

$$r(t) = r_e + A \cos(k\omega t) + B \sin(k\omega t)$$

$$\exp(i\theta) = \cos\theta + i \sin\theta \quad \text{and} \quad \exp(-i\theta) = \cos\theta - i \sin\theta$$

Euler's formulae for positive and negative exponentials may be added together and after rearrangement gives $\cos(\theta)$ in terms of complex numbers. Subtraction and rearrangement gives $\sin(\theta)$ in terms of complex numbers. Note that we only need to remember Euler's formulae we do *not* need to remember the trig equations, certainly I don't remember them.

$$\cos\theta = \frac{1}{2}(\exp(i\theta) + \exp(-i\theta)) \quad \text{and} \quad \sin\theta = \frac{1}{i2}(\exp(i\theta) - \exp(-i\theta))$$

We can now substitute for $\cos(k\omega t)$ and $\sin(k\omega t)$ in our equation for simple harmonic motion where we have let $\theta = k\omega t$.

$$r(t) = r_e + \frac{A}{2}(\exp(ik\omega t) + \exp(-ik\omega t)) + \frac{B}{i2}(\exp(ik\omega t) - \exp(-ik\omega t))$$

Expanding out the brackets,

$$r(t) = r_e + \frac{A}{2} \exp(ik\omega t) + \frac{A}{2} \exp(-ik\omega t) + \frac{B}{i2} \exp(ik\omega t) - \frac{B}{i2} \exp(-ik\omega t)$$

In the last two terms we are dividing by i which is the same as multiplying by $-i$ which is shown below as an aside and comes from multiplying and dividing by i ,

$$\frac{1}{i} = \frac{1}{i} \times \frac{i}{i} = \frac{i}{i^2} = \frac{i}{-1} = -i$$

$$r(t) = r_e + \frac{A}{2} \exp(ik\omega t) + \frac{A}{2} \exp(-ik\omega t) - \frac{iB}{2} \exp(ik\omega t) + \frac{iB}{2} \exp(-ik\omega t)$$

Collecting the terms with the same exponents gives,

$$r(t) = r_e + \frac{A - iB}{2} \exp(ik\omega t) + \frac{A + iB}{2} \exp(-ik\omega t)$$

[Return to Question 3 \(see page 65\)](#)

4 Week 4: Chemistry and Complex Numbers

4.1 Week 4 Tutorial Questions

4.1.1 Question 1: Particle In A One-Dimensional Box

Quantum effects are dominant in many areas of Chemistry and Biology. A simple system that shows how quantum effects arise is the particle in a box. The particle may be an electron, atom, ion or molecule dependent upon the system being studied. The first three wavefunctions for $n = 1, 2,$ and 3 are shown in Fig. 4.1 which has a vertical axis *not* to scale. The wavefunction increases and decreases with the distance along the box and thus is best modelled using complex numbers.

The wavefunctions ψ for the particle in a one dimensional box are given by the following complex-function

$$\psi(x) = \sqrt{\frac{2}{L}} \frac{1}{i2} (\exp(inx) - \exp(-inx))$$

gaieteye
Challenge the way we run

EXPERIENCE THE POWER OF FULL ENGAGEMENT...

**RUN FASTER.
RUN LONGER..
RUN EASIER...**

**READ MORE & PRE-ORDER TODAY
WWW.GAITEYE.COM**

Where L is the length of the box, x is the position of the particle within the box and n is a constant called the translational quantum number $n = 1, 2, 3, 4, \dots$. Simplify this expression to obtain a real valued function.

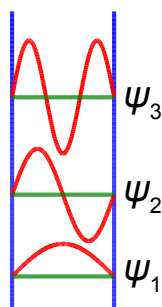

Figure 4.1: lower energy wavefunctions for a particle in a box in red, with zero values in green.

[Jump to Solution 1 \(see page 73\)](#)

4.1.2 Question 2: X-Ray Crystallography Structure Factors

X-ray diffraction is a standard method of chemical analysis to determine the structure of crystalline solids. The X-rays photons are scattered from the electrons in the atoms and interfere to give bright spots, *i.e.* the crystal planes of atoms act as diffraction gratings. The crystal planes of atoms are described by *Miller indices* ($h k l$) from the ratios of the plane's coordinates (x, y, z) to the lengths of the axes of the unit cell a, b, c (which are not necessarily at right angles). We then take the reciprocal of these ratios; and if necessary multiply these reciprocals by the smallest number to converted them to integers. In Fig. 4.2 the crystal plane are shown in blue and these Miller indices become really useful for the planes that are parallel to the an axis. So for the top diagrams the first plane which is *not at the origin* is a $1a$, and it is parallel to the b and c axes so these intercepts are both at $1a, \infty b, \infty c$ which gives the ratios and the plane's Miller indices using the fact that $1/\infty = 0$.

$$\frac{1}{1} \frac{1}{\infty} \frac{1}{\infty} \quad (h k l) = (100)$$

In the middle diagram the first plane not at the origin has intercepts at $\frac{1}{2}a, \frac{1}{2}b$, and ∞c , giving the ratio and Miller indices,

$$\frac{1}{\frac{1}{2}} \frac{1}{\frac{1}{2}} \frac{1}{\infty} \quad (h k l) = (220)$$

In the bottom diagram the first plane not at the origin has intercepts at a, b, c which gives the ratios and Miller indices.

$$\frac{1}{1} \frac{1}{1} \frac{1}{1} \quad (h k l) = (111)$$

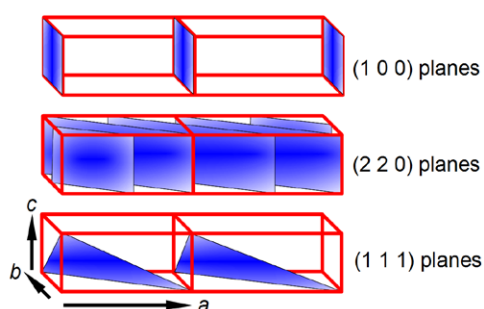

Figure 4.2: a crystal with two unit cells and three types of crystal planes.

The intensity of the scattered beam of X-rays from the hkl plane of a crystal is proportional to F^*F where F , the structure factor for a particular crystal is determined by the positions of the atoms in the various crystal planes and F^* is its complex conjugate.

$$F(hkl) = \sum_j f_j \exp(i2\pi(hx_j + ky_j + lz_j))$$

The summation runs over j the number of atoms in the unit cell, with each atom having a scattering factor f_j and fractional coordinates (x_j, y_j, z_j) within the unit cell.

Metallic sodium crystals have a body-centred cubic structure with two atoms per unit cell located at $(0,0,0)$ and $(\frac{1}{2}, \frac{1}{2}, \frac{1}{2})$ respectively. Firstly, use the above equation to find F the structure factor for metallic sodium, and secondly, use Euler's formula to determine its real and imaginary parts. Thirdly, show that X-ray diffractions "reflections" occur (*i.e.* $F(hkl) \neq 0$) only if the quantity $h+k+l$ is even, but not if it is odd.

[Jump to Solution 2 \(see page 74\)](#)

4.1.3 Question 3: Dielectric Constant of a Solution of Polar Molecules

An alternating electric field of frequency ω has an electric field, $E = E_0 \exp(i\omega\tau)$, which varies with time τ ("tau"). Applying an alternating field to a dilute solution of polar molecules allows you to measure the effect of the *solvent* with the polar molecules in the solution. This solvent effect is called the dielectric constant ϵ of the solution at the frequency ω of the applied field. For example, water which is very polar has a dielectric constant of 80.10 at 20°C but *n*-hexane which is very non-polar has a dielectric constant of 1.89 at 20°C. This information is of great value in deciding which solvent(s) to use in designing separation methods, for sample preparation and in the chromatography techniques used in analytical chemistry.

The dielectric constant of a solution is,

$$\epsilon - n^2 = \frac{N_0 \rho \mu^2}{3M \epsilon_0 k_B T (1 + i\omega\tau)}$$

The dielectric constant ϵ is a complex number and is conventionally written as,

$$\epsilon = \epsilon' + i\epsilon''$$

The parameters n , N_p , ρ , M , ϵ_0 , μ , k_p , T are all constants at a constant temperature T . Experimentally we measure the real part of the dielectric constant ϵ so rewrite the above equation to determine the real part ϵ' of this complex dielectric constant.

[Jump to Solution 3 \(see page 75\)](#)

4.1.4 Question 4: Polymer Electrolytes and Impedance Spectroscopy

New batteries for car, laptops, tablet computers and mobiles are developed by Chemists. These batteries are now made from *polymer electrolytes* as these can offer significant performance improvements.



**Technical training on
WHAT you need, WHEN you need it**

At IDC Technologies we can tailor our technical and engineering training workshops to suit your needs. We have extensive experience in training technical and engineering staff and have trained people in organisations such as General Motors, Shell, Siemens, BHP and Honeywell to name a few.

Our onsite training is cost effective, convenient and completely customisable to the technical and engineering areas you want covered. Our workshops are all comprehensive hands-on learning experiences with ample time given to practical sessions and demonstrations. We communicate well to ensure that workshop content and timing match the knowledge, skills, and abilities of the participants.

We run onsite training all year round and hold the workshops on your premises or a venue of your choice for your convenience.

For a no obligation proposal, contact us today at training@idc-online.com or visit our website for more information: www.idc-online.com/onsite/

OIL & GAS ENGINEERING
ELECTRONICS
AUTOMATION & PROCESS CONTROL
MECHANICAL ENGINEERING
INDUSTRIAL DATA COMMS
ELECTRICAL POWER

Phone: +61 8 9321 1702
Email: training@idc-online.com
Website: www.idc-online.com

IDC TECHNOLOGIES

One tool that is often used to characterise the behaviour of these polymer electrolytes is the technique of impedance spectroscopy, where the electrical impedance Z of a sample is measured as a function of an applied alternating current of angular frequency ω . The impedance Z is the opposition to the flow of an *alternating* current and is measured in ohms. Angular frequency $\omega = 2\pi/T$ where T is the period of rotation in seconds, so ω is in radians/second and is equal to $2\pi\nu$ where ν is the ordinary frequency in hertz or s^{-1} . It is found experimentally that some materials exhibit an impedance response that is given by the following equation

$$Z(\omega) = \frac{R_0}{1 + i\omega\tau}$$

Where R_0 is the direct current (DC) resistance of the polymer electrolyte and is a constant and τ (tau) is the time. It is found that impedance is a complex variable,

$$Z(\omega) = x(\omega) + iy(\omega)$$

Firstly, find the expressions for the real and the imaginary parts of the impedance equation *i.e.* find expressions for both $x(\omega)$ and $y(\omega)$. Secondly, eliminate $\omega\tau$ from these equations and graph $Z(\omega)$ in the complex plane as a function of ω and show it is a circle. Find the (x, y) coordinates of its centre and the radius of the circle. For a good polymer electrolyte for a new battery, we will need a high ionic conductivity *i.e.* a low DC resistance, R_0 . As a hint the equation for a circle with its centre at (a, b) and radius r is,

$$(x - a)^2 + (y - b)^2 = r^2$$

[Jump to Solution 4 \(see page 76\)](#)

4.2 Week 4 Tutorial Solutions

4.2.1 Solution 1: Particle In A One-Dimensional Box

$$\psi(x) = \sqrt{\frac{2}{L}} \frac{1}{i2} (\exp(inx) - \exp(-inx))$$

Substituting from Euler's formulae written in terms of (inx) we have,

$$\psi(x) = \sqrt{\frac{2}{L}} \frac{1}{i2} (\cos(nx) + i\sin(nx) - \cos(nx) + i\sin(nx))$$

$$\psi(x) = \sqrt{\frac{2}{L}} \frac{1}{i2} i2\sin(nx)$$

$$\psi(x) = \sqrt{\frac{2}{L}} \sin(nx)$$

This is a real wavefunction.

[Return to Question 1 \(see page 69\)](#)

4.2.2 Solution 2: X-Ray Crystallography Structure Factors

Firstly, from the definition of the structure factor, we have to substitute the values for each atom in the unit cell.

$$F(hkl) = \sum_j f_j \exp(i2\pi(hx_j + ky_j + lz_j))$$

Atom 1 has a scattering factor f_{Na} and coordinates (0, 0, 0),

$$f_{\text{Na}} \exp(i2\pi(h0 + k0 + l0)) = f_{\text{Na}} \exp(i2\pi 0) = f_{\text{Na}}$$

since $\exp(0) = 1$ the first sodium atom's contribution to the structure factor F summation is just f_{Na} .

Atom 2 has a scattering factor f_{Na} and coordinates $(\frac{1}{2}, \frac{1}{2}, \frac{1}{2})$ and makes a contribution to the summation of,

$$f_{\text{Na}} \exp\left(i2\pi\left(\frac{h}{2} + \frac{k}{2} + \frac{l}{2}\right)\right) = f_{\text{Na}} \exp(i\pi(h + k + l))$$

Adding the effects for the two atoms gives the structure factor F for metallic sodium's body-centred unit cell,

$$F(hkl) = f_{\text{Na}} + f_{\text{Na}} \exp(i\pi(h + k + l))$$

Secondly, using Euler's formula we will determine the real and imaginary parts of the structure factor F .

$$\exp(i\pi) = \cos(180^\circ) + i \sin(180^\circ) = -1 + i(0) = -1$$

where we must use radians (π radians = 180°). For the *particular* example of a body-centred cubic structure the real part is -1 and the imaginary part is zero, but this will not necessarily happen for other crystal structures!

Thirdly, we have to investigate the behaviour of the function $\exp(i\pi(h + k + l))$ for different values of $h+k+l$. As h , k and l are all integer quantities their sum must also be an integer. Let's call this sum $N = h + k + l$ and we must now look at the behaviour of $\exp(iN\pi)$ for various values of integer N . So we have when $N = 1, 3, 5, \dots$

$$\exp(iN\pi) = \cos(N180^\circ) + i \sin(N180^\circ) = -1 + i(0) = -1$$

substituting this value for $\exp(iN\pi)$ into $F(hkl)$ gives $F(hkl) = 0$ for $N = \text{odd}$. When $N = 2, 4, 6, \dots$,

$$\exp(iN\pi) = \cos(N0^\circ) + i \sin(N0^\circ) = +1 + i(0) = +1$$

This means that the structure factor F is either of the two values given below dependent upon the Miller indices of the crystal plane,

$$F(hkl) = 2f_{\text{Na}} \quad \text{for } N = h + k + l = \text{even}$$

$$F(hkl) = 0 \quad \text{for } N = h + k + l = \text{odd}$$

i.e. there is *no* X-ray scattering observed for $h + k + l = \text{odd}$ crystal planes but only from $h + k + l = \text{even}$ planes for the particular crystal structure of metallic sodium.

[Return to Question 2 \(see page 70\)](#)

4.2.3 Solution 3: Dielectric Constant of a Solution of Polar Molecules

$$\epsilon - n^2 = \frac{N_0 \rho \mu^2}{3M \epsilon_0 k_B T (1 + i\omega\tau)}$$

$$\epsilon' + \epsilon'' = n^2 + \frac{N_0 \rho \mu^2}{3M \epsilon_0 k_B T (1 + i\omega\tau)}$$

I joined MITAS because
I wanted **real responsibility**

The Graduate Programme
for Engineers and Geoscientists
www.discovermitas.com



Month 16

I was a construction
supervisor in
the North Sea
advising and
helping foremen
solve problems

Real work
International opportunities
Three work placements



 **MAERSK**

Consider the term $1/(1 + i\omega\tau)$ as it is the only term containing i and the rest of the terms on the right hand side are just constants. The $1/(1 + i\omega\tau)$ term is division by a complex number and when we multiply it top and bottom by the complex conjugate of the denominator and simplify we find the real part of this is,

$$\frac{1}{1 + i\omega\tau} = \frac{1}{1 + i\omega\tau} \times \frac{1 - i\omega\tau}{1 - i\omega\tau} = \frac{1 - i\omega\tau}{1 + \omega^2\tau^2}$$

$$\frac{1 - i\omega\tau}{1 + \omega^2\tau^2} = \frac{1}{1 + \omega^2\tau^2} - i \frac{\omega\tau}{1 + \omega^2\tau^2}$$

$$\operatorname{Re} \frac{1}{1 + i\omega\tau} = \frac{1}{1 + \omega^2\tau^2}$$

So the real part of the original equation can be rewritten, see below, and it is this part of the dielectric constant of the battery polymer electrolyte that is measured experimentally.

$$\epsilon' = n^2 + \frac{N_0 \rho \mu^2}{3M \epsilon_0 k_B T (1 + \omega^2 \tau^2)}$$

[Return to Question 3 \(see page 71\)](#)

4.2.4 Solution 4: Polymer Electrolytes and Impedance Spectroscopy

This has a similar solution to the last question but with a twist in the plot! First evaluate the real and imaginary parts by multiplying top and bottom by the complex conjugate.

$$Z(\omega) = \frac{R_0}{1 + i\omega\tau}$$

$$Z(\omega) = \frac{R_0}{1 + i\omega\tau} \times \frac{1 - i\omega\tau}{1 - i\omega\tau} = \frac{R_0 - iR_0\omega\tau}{1 + \omega^2\tau^2} = \frac{R_0}{1 + \omega^2\tau^2} - i \frac{R_0\omega\tau}{1 + \omega^2\tau^2}$$

In impedance spectroscopy this is usually written as below which gives us the twist that $y(\omega)$ is a function of $x(\omega)$,

$$Z(\omega) = x(\omega) + iy(\omega)$$

$$x(\omega) = \frac{R_0}{1 + \omega^2\tau^2}$$

$$y(\omega) = - \frac{R_0\omega\tau}{1 + \omega^2\tau^2} = - (\omega\tau) x(\omega)$$

$$\omega\tau = - \frac{y(\omega)}{x(\omega)} \quad (\omega\tau)^2 = \frac{y(\omega)^2}{x(\omega)^2}$$

Thus on substituting for $(\omega\tau)^2$ in the equation for the real part of the impedance, $x(\omega)$, and for clarity dropping the reminder that x and y are both functions of the angular frequency ω we have,

$$x = \frac{R_0}{1 + y^2/x^2}$$

Now multiply both sides of this equation by the denominator $(1+y^2/x^2)$ and simplifying further,

$$x + \frac{y^2}{x} = R_0 \quad x^2 + y^2 = R_0 x \quad x^2 - R_0 x + y^2 = 0$$

Add $\frac{1}{4}R_0^2$ to each side so that *all* the terms can be written as squares (completing the squares method)

$$x^2 - R_0 x + \frac{R_0^2}{4} + y^2 = \frac{R_0^2}{4}$$

$$\left(x - \frac{R_0}{2}\right)^2 + y^2 = \left(\frac{R_0}{2}\right)^2$$

As suggested in the question, this is the equation for a circle with centre at $(\frac{1}{2}R_0, 0)$ and radius $\frac{1}{2}R_0$, with the circle lying in the x - y plane (the $\text{Re}(Z)$ - $\text{Im}(Z)$ plane) as in Fig. 4.3 which is drawn for $R_0 = 10$ ohms.

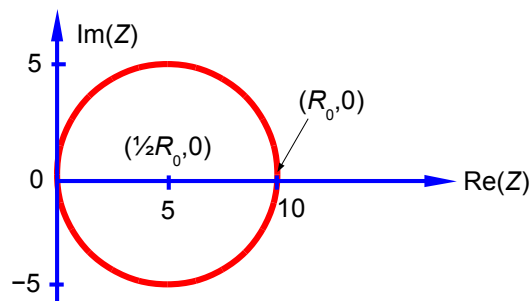

Figure 4.3: $\text{Im}(Z)$ versus $\text{Re}(Z)$ of a polymer electrolyte of $R_0 = 10$ ohms.

[Return to Question 4 \(see page 72\)](#)

5 Week 5: Chemistry and Matrices

5.1 Why use Matrices with Chemistry?

One of the most obvious uses of matrices is to organize the data of several simultaneous equations in a compact form so it can be manipulated and easily solved. This is most commonly used in Analytical Chemistry. A set of linear simultaneous equations consisting of *numerical* values for the coefficients A and the values b can be solved for the unknown variables x when it is written in matrix form $Ax = b$. As we need as many simultaneous equations as there are unknown variables we will have a square matrix for A . If we multiply by the inverse of A on both sides it gives $A^{-1}Ax = A^{-1}b$ or $Ix = A^{-1}b$ where I is the identity matrix and so $x = A^{-1}b$. So the problem is reduced to finding the inverse matrix. To find the inverse we have to do several things, firstly find the determinant of A , $|A|$, and secondly, the matrix of cofactors of A , C , and then the transpose of C ($C^T = \text{adj } A$ the adjunct of A). Here is a simple reminder of these steps for the set of simultaneous equations below we have the A matrix,

$$\begin{aligned}5x_1 + 2x_2 + 3x_3 &= 4 \\4x_1 + 1x_2 + 6x_3 &= 3 \\8x_1 + 0x_2 + 7x_3 &= -2\end{aligned}$$



www.job.oticon.dk

oticon
PEOPLE FIRST



$$A = \begin{pmatrix} 5 & 2 & 3 \\ 4 & 1 & 6 \\ 8 & 0 & 7 \end{pmatrix} \quad |A| = +5(1 \times 7 - 6 \times 0) - 2(4 \times 7 - 6 \times 8) + 3(4 \times 0 - 1 \times 8)$$

$$|A| = +5(7) - 2(-20) + 3(-8) = +35 + 40 - 24 = 51$$

$$|A| = 51$$

The matrix of cofactors, C , of A is

$$C = \begin{pmatrix} +(1 \times 7 - 6 \times 0) & -(4 \times 7 - 6 \times 8) & +(4 \times 0 - 1 \times 8) \\ -(2 \times 7 - 3 \times 0) & +(5 \times 7 - 3 \times 8) & -(5 \times 0 - 2 \times 8) \\ +(2 \times 6 - 3 \times 1) & -(5 \times 6 - 3 \times 4) & +(5 \times 1 - 2 \times 4) \end{pmatrix} = \begin{pmatrix} +7 & +20 & -8 \\ -14 & +11 & +16 \\ +9 & -18 & -3 \end{pmatrix}$$

The transpose of C is C^T is,

$$C^T = \begin{pmatrix} 7 & -14 & 9 \\ 20 & 11 & -18 \\ -8 & 16 & -3 \end{pmatrix}$$

Putting it all together, we have the inverse of A is now,

$$A^{-1} = \frac{1}{|A|} C^T = \frac{1}{51} \begin{pmatrix} 7 & -14 & 9 \\ 20 & 11 & -18 \\ -8 & 16 & -3 \end{pmatrix}$$

The solutions of the simultaneous equations are as follows,

$$x = A^{-1} b \quad x = \frac{1}{|A|} C^T b$$

Substituting in for the determinant of A , the transpose of cofactors (C^T the adjunct of A), and the values for b

$$x = \frac{1}{51} \begin{pmatrix} 7 & -14 & 9 \\ 20 & 11 & -18 \\ -8 & 16 & -3 \end{pmatrix} \begin{pmatrix} 4 \\ 3 \\ -2 \end{pmatrix}$$

$$x = \frac{1}{51} \begin{pmatrix} 4(7) + 3(-14) + (-2)(9) \\ 4(20) + 3(11) + (-2)(-18) \\ 4(-8) + 3(16) + (-2)(-3) \end{pmatrix} = \frac{1}{51} \begin{pmatrix} -32 \\ 149 \\ 22 \end{pmatrix}$$

$$x = \begin{pmatrix} -0.627 \\ 2.922 \\ 0.431 \end{pmatrix}$$

$$x_1 = -0.627 \quad x_2 = 2.922 \quad x_3 = 0.431$$

Solving small numerical matrices by hand may be fine and it is something you need to do for *exam questions*! But for large matrices I will show you later a simple spreadsheet approach.

A second use of matrices in Chemistry is the efficient handling of the symmetry operations that apply to molecules. The shape of molecules is one of their most important properties and the shape is defined by the symmetry operations that they can undergo. A molecule has a particular shape or symmetry which may be transformed in three-dimensional space by rotations around its symmetry axes; reflections in its mirror planes; rotation-reflection (or improper rotation); inversions through a centre of symmetry; and the identity operation.

A third area in Chemistry where matrices are used is the eigenvalues and eigenvectors of the determinant of square a matrix to find the allowed solutions to the quantum mechanics of the structures and reaction pathways of a molecule. This last area is covered in Week 6. You may not yet have covered some of these areas of Chemistry in your undergraduate course. *Don't worry* they will be introduced as you move through your Chemistry degree and you will already be able to do the Maths!

5.2 Week 5 Tutorial Questions

5.2.1 Question 1: Chemical Ore Analysis

In the lab an analytical Chemist measures the fractional Pb, Fe, Cu and Mn content on a weight for weight basis for three ores, her results are shown in Fig. 5.1.

	Ore 1	Ore 2	Ore 3
Pb	0.1	0.2	0.3
Fe	0.2	0.3	0.3
Cu	0.6	0.2	0.2
Mn	0.1	0.3	0.2

Figure 5.1: metal analysis of three ores.

If the ores are mixed together so there are x_1 kg of Ore 1, x_2 kg of Ore 2, and x_3 kg of Ore 3, the amount of each metal in the mixture can be computed as shown in Fig. 5.2.

Amount of Pb =	$A_{\text{Pb}} =$	$0.1x_1 + 0.2x_2 + 0.3x_3$
Amount of Fe =	$A_{\text{Fe}} =$	$0.2x_1 + 0.3x_2 + 0.3x_3$
Amount of Cu =	$A_{\text{Cu}} =$	$0.6x_1 + 0.2x_2 + 0.2x_3$
Amount of Mn =	$A_{\text{Mn}} =$	$0.1x_1 + 0.3x_2 + 0.2x_3$

Figure 5.2: ore mixture.

Firstly, rewrite the above series of equations in matrix form $A = FX$ where F is a 4×3 matrix containing the fractional elemental compositions; A and X are column matrices containing the total amount of each element and the quantities of each ore respectively. Secondly, calculate the percent weight for weight (%w/w) of each element in a 10 kg mixture of the ores containing 4 kg of Ore 1, 3 kg of Ore 2 and 3 kg of Ore 3.

[Jump to Solution 1 \(see page 89\)](#)

5.2.2 Question 2: Chemical Connectivity

Matrices can be used to represent molecular connectivity to show, using Maths, those atoms which are bonded to one another. For example, ethene, or ethylene, with the atoms numbered for easy reference, is shown in Fig. 5.3.

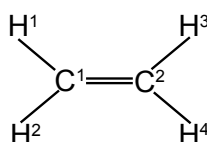

Figure 5.3: ethene connectivity.

Schlumberger

WHY WAIT FOR PROGRESS?

DARE TO DISCOVER

Discovery means many different things at Schlumberger. But it's the spirit that unites every single one of us. It doesn't matter whether they join our business, engineering or technology teams, our trainees push boundaries, break new ground and deliver the exceptional. If that excites you, then we want to hear from you.

careers.slb.com/recentgraduates

A connectivity table is shown below, Fig. 5.4, as follows: on the diagonal elements of the matrix, place an α (Greek alpha); on the off-diagonal elements where an atom is bonded to the *indicated* atom place a β (Greek beta); and on the off-diagonal elements where an atom is *not* bonded to the indicated atom place a 0 (zero). The connectivity table can be conveniently written in matrix form and we will use this type of matrix later on for carrying out some symmetry operations and also we will use some related matrices for molecular orbital calculations.

	C ¹	C ²	H ¹	H ²	H ³	H ⁴
C ¹	α	β	β	β	0	0
C ²	β	α	0	0	β	β
H ¹	β	0	α	0	0	0
H ²	β	0	0	α	0	0
H ³	0	β	0	0	α	0
H ⁴	0	β	0	0	0	α

$$\begin{pmatrix} \alpha & \beta & \beta & \beta & 0 & 0 \\ \beta & \alpha & 0 & 0 & \beta & \beta \\ \beta & 0 & \alpha & 0 & 0 & 0 \\ \beta & 0 & 0 & \alpha & 0 & 0 \\ 0 & \beta & 0 & 0 & \alpha & 0 \\ 0 & \beta & 0 & 0 & 0 & \alpha \end{pmatrix}$$

Figure 5.4: ethene connectivity table and its corresponding matrix.

Firstly, draw up similar connectivity matrices for the following molecules: sulfurhexafluoride (SF₆), ethane, and diborane (B₂H₆), all shown in Fig. 5.5.

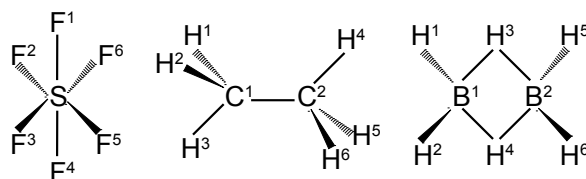

Figure 5.5: sulfurhexafluoride, ethane, and diborane.

Secondly, draw up connectivity matrices for the following unsaturated molecules and radicals; ethene (Fig. 5.3) and those shown in Figs. 5.6 and 5.7 but now only consider the *heavy atoms* and ignore the connectivity of the hydrogen atoms.

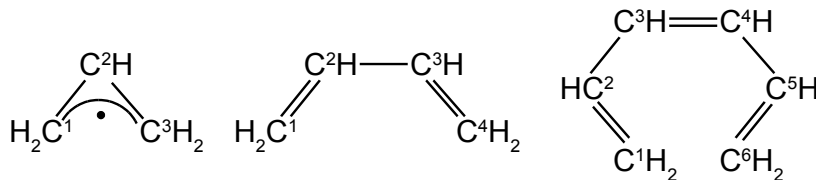

Figure 5.6: allyl radical, butadiene, and hexatriene.

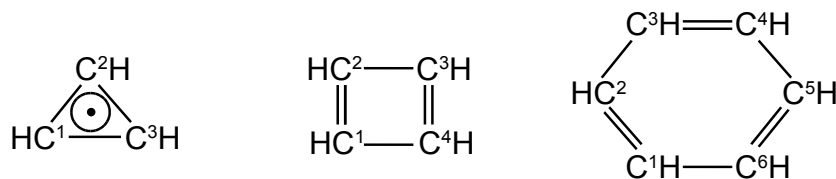

Figure 5.7: cyclopropenyl radical, cyclobutadiene, and benzene.

[Jump to Solution 2 \(see page 89\)](#)

5.2.3 Question 3: Molecular Symmetry Operations, Linear Transformations

The positions of atoms in a molecule can be defined in terms of Cartesian coordinates x, y, z . In the analysis of molecular geometry there is often a need to calculate atomic coordinates and then subsequently find their new positions (using matrices) due to the symmetry operations of reflection, inversion, rotation and rotation-reflection.

Consider the anticlockwise rotation, around the z -axis, of an atom with coordinates $X(x, y)$ through an angle θ to the new position $X'(x', y')$ as in Fig. 5. 8,

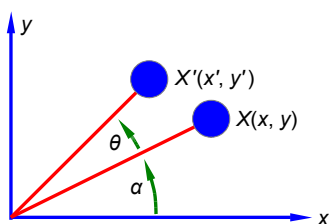

Figure 5.8: rotation of an atom at position X to position X' .

What is the appropriate 2×2 matrix R for this rotational transformation such that,

$$X' = XR$$

Assuming that the z -axis is pointing out from the xy -plane (the right hand rule), how would matrix R need to be modified for a more general anticlockwise rotation about the z -axis of a point with coordinates (x, y, z) ?

[Jump to Solution 3 \(see page 92\)](#)

5.2.4 Question 4: Three-Dimensional Molecular Symmetry Operations

For transformations in three dimensions, find matrix equations that represent the following operations.

1. Anticlockwise rotation about the x -axis.
2. Anticlockwise rotation about the y -axis.
3. Reflection in the xy -plane.
4. Reflection in the yz -plane.
5. Reflection in the zx -plane.
6. Inversion through the origin.

[Jump to Solution 4 \(see page 94\)](#)

5.2.5 Question 5: Molecular Structure Analysis of Cyclic Molecules

Calculate a set of Cartesian coordinates with respect to the origin for firstly, the carbon atoms only of benzene given that the C-C bond distance is 1.40 \AA and the benzene ring is a regular hexagon, Fig. 5.9. Secondly, the carbon atoms only of the cyclopentadiene anion given that the C-C bond distance is 1.40 \AA and the five membered ring is a regular pentagon. To tackle this question find the coordinates of C^1 and then apply the appropriate symmetry operations to find the coordinates of the remaining carbon atoms.



PREPARE FOR A LEADING ROLE.

English-taught MSc programmes in engineering: Aeronautical, Biomedical, Electronics, Mechanical, Communication systems and Transport systems. No tuition fees.

→ liu.se/master

li.u LINKÖPING UNIVERSITY



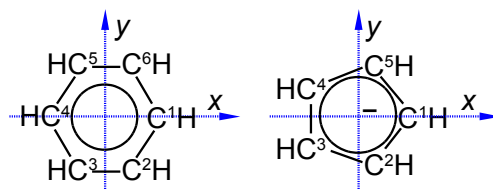

Figure 5.9: benzene and cyclopentadiene anion.

[Jump to Solution 5 \(see page 95\)](#)

5.2.6 Question 6: Methane Molecular Structure Analysis

Calculate a set of Cartesian coordinates to 4 significant figures with respect to the origin for the carbon and hydrogen atoms of a methane molecule as shown in Fig. 5.10 given that the C-H bond distance is 1.091 \AA and the H-C-H tetrahedral angle is 109.47° .

For ease of calculation note that H^1 , H^2 and H^3 form an equilateral triangle and lie in a plane *parallel* to the yz -axis. Thus find the coordinates for H^4 which gives H^1 by rotation around the z -axis, and then find H^2 and H^3 by $+120^\circ$ and -120° rotation about the x -axis of H^1 .

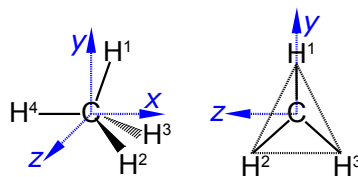

Figure 5.10: methane molecular structure analysis

[Jump to Solution 6 \(see page 97\)](#)

5.2.7 Question 7: Ethane Molecular Structure Analysis

Using the coordinate data from the solution to Question 6, and so find the coordinates for the carbon and hydrogen atoms in ethane for the eclipsed (Fig. 5.11 on the left) and staggered (Fig. 5.11 on the right) conformations. The C-C bond length is 1.541 \AA and C-H bond distance is 1.091 \AA as above and all bond angles are tetrahedral. You may find it helpful in each case to make a molecular model and consider the symmetry relationships between corresponding atoms in each of the structures.

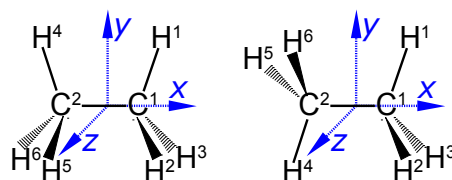

Figure 5.11: ethane eclipsed and staggered conformations.

[Jump to Solution 7 \(see page 98\)](#)

5.2.8 Question 8: Chemistry and Simultaneous Equations

There is a linear relationship between the Celsius and Fahrenheit temperature scales such that

$$T_F = mT_C + C$$

Given that the freezing point of pure water is 32°F and 0°C, and the boiling point of pure water 212°F and 100°C, draw up a pair of associated linear equations, transform into matrix form and hence obtain values for the m and C .

[Jump to Solution 8 \(see page 99\)](#)

5.2.9 Question 9: The Speed of Chemical Reactions

The Arrhenius equation is an important equation in reaction kinetics

$$k = A \exp\left(\frac{-E_a}{RT}\right)$$

where k is the rate constant, A is the pre-exponential factor, E_a is the activation energy, T is the temperature in kelvin, and R is the gas constant. This can be rearranged into a linear form by taking natural logarithms of both sides,

$$\ln k = \ln A - \frac{E_a}{R} \frac{1}{T}$$

If the value of k can be measured at a series of temperatures T , then the two unknown parameters A and E_a can be calculated by solving the resulting simultaneous equations.

The initial stage of the reaction between ammonia and nitrous oxide follows second order kinetics. Given that the rate constant at 600 K is 0.385 L mol⁻¹ s⁻¹ and at 716 K is 16.0 L mol⁻¹ s⁻¹, calculate the activation energy E_a , and the pre-exponential factor A to 3 significant figures.

[Jump to Solution 9 \(see page 100\)](#)

5.2.10 Question 10: Chemical Analysis of Well Separated Spectral Regions

For a single absorbing molecular species in solution, the Beer-Lambert Law states that

$$A = \epsilon l c$$

where A is the absorbance, ϵ is the molar absorptivity (extinction coefficient), l is the path length of the cell containing the absorbing solution (usually 1 cm) and c is the concentration of the solution in mol L^{-1} . If a mixture has spectra for each of the individual component compounds of the mixture which has regions (shown in Fig. 5.12 as dotted vertical lines) where each component dominates the spectrum, then we can use straight forward matrix algebra to determine the concentrations of the mixture components.

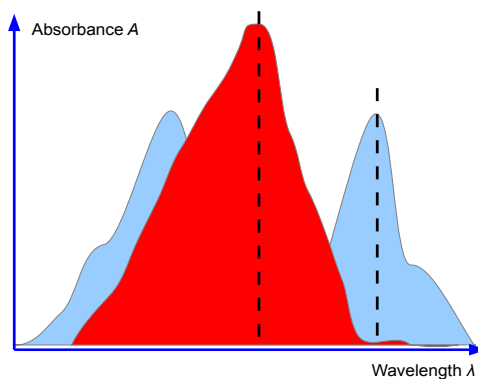

Figure 5.12: spectra with dominant regions.

Click here
to learn more

TAKE THE RIGHT TRACK

Give your career a head start
by studying with us. Experience the advantages
of our collaboration with major companies like
ABB, Volvo and Ericsson!

Apply by
15 January

World class
research

www.mdh.se

MÄLARDALEN UNIVERSITY
SWEDEN

For a solution containing *two* absorbing species X and Y the overall absorbance measured (A_{total}) would be the sum of the individual absorbances at wavelengths chosen so that one of the components is the major contributor (the black dashed lines in Fig. 5.12). For a two component mixture we need two such wavelengths to give two simultaneous equations

$$A_{\text{total}} = \epsilon_1 l c_1 + \epsilon_2 l c_2$$

A student in the teaching lab measured the following absorptivities using a 1 cm path length cuvette for the pure components known to be in the mixture

λ/nm	$\epsilon_X/\text{L mol}^{-1} \text{cm}^{-1}$	$\epsilon_Y/\text{L mol}^{-1} \text{cm}^{-1}$
285	16441	3872
338	3993	6423

Figure 5.13: molar extension coefficients for pure X and Y.

The student was given an unknown mixture of the two compounds X and Y and measured in a 1 cm cuvette the total absorbances of 0.952 at 285 nm and 0.553 at 338 nm. Find the concentrations of X and Y in the mixture by rewriting the data in matrix form for the two simultaneous equations and solving them by the appropriate matrix manipulations.

[Jump to Solution 10 \(see page 101\)](#)

5.2.11 Question 11: Chemical Analysis of the Spectra of Three or More Components

A student in their lab class measured the following spectroscopic data for some pure samples of three indicators thymol blue (TB), semithymol blue (STB) and methylthymol blue (MTB), Fig. 5.14.

	TB	STB	MTB	Mixture	Mixture
λ/nm	$\epsilon_X/\text{L mol}^{-1} \text{cm}^{-1}$	$\epsilon_Y/\text{L mol}^{-1} \text{cm}^{-1}$	$\epsilon_X/\text{L mol}^{-1} \text{cm}^{-1}$	A	Concn.
455	4800	11100	18900	0.4745	3.5230E-06
485	7350	11200	11800	0.3394	6.5143E-06
545	36400	13900	4450	0.3095	2.0385E-05

Figure 5.14: absorptivities for pure TB, STB and MTB and absorbances for a mixture.

Rewrite the data in matrix form and by appropriate matrix manipulation; find the concentrations of TB, STB and MTB in the mixture. You should *attempt* the manual approach which we have used up until now and find the difficulties involved. I will show you how to use a spreadsheet with matrix functions to solve this problem in section 5.3.11.

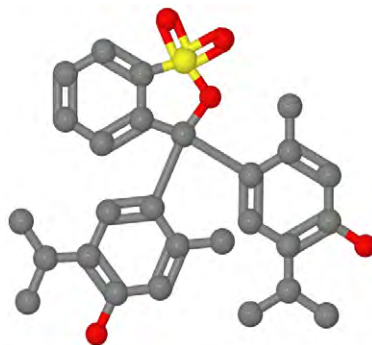

Figure 5.15: 2-dimensional model of thymol blue, S= yellow, O = red, H is not shown.

[Jump to Solution 11 \(see page 103\)](#)

5.3 Week 5 Tutorial Solutions

5.3.1 Solution 1: Chemical Ore Analysis

Firstly, the Analytical Chemists results written in matrix form are given below, where $A = FX$.

$$A = \begin{pmatrix} A_{\text{Pb}} \\ A_{\text{Fe}} \\ A_{\text{Cu}} \\ A_{\text{Mn}} \end{pmatrix} \quad F = \begin{pmatrix} 0.1 & 0.2 & 0.3 \\ 0.2 & 0.3 & 0.3 \\ 0.6 & 0.2 & 0.2 \\ 0.1 & 0.3 & 0.2 \end{pmatrix} \quad X = \begin{pmatrix} x_1 \\ x_2 \\ x_3 \end{pmatrix}$$

For the 10 kg of the mixed ores, the product of a 4×3 matrix and a 3×1 matrix is a 4×1 matrix,

$$\begin{pmatrix} A_{\text{Pb}} \\ A_{\text{Fe}} \\ A_{\text{Cu}} \\ A_{\text{Mn}} \end{pmatrix} = \begin{pmatrix} 0.1 & 0.2 & 0.3 \\ 0.2 & 0.3 & 0.3 \\ 0.6 & 0.2 & 0.2 \\ 0.1 & 0.3 & 0.2 \end{pmatrix} \begin{pmatrix} 4 \\ 3 \\ 3 \end{pmatrix} = \begin{pmatrix} 0.1 \times 4 + 0.2 \times 3 + 0.3 \times 3 \\ 0.2 \times 4 + 0.3 \times 3 + 0.3 \times 3 \\ 0.6 \times 4 + 0.2 \times 3 + 0.2 \times 3 \\ 0.1 \times 4 + 0.3 \times 3 + 0.2 \times 3 \end{pmatrix} = \begin{pmatrix} 1.9 \\ 2.6 \\ 3.6 \\ 1.9 \end{pmatrix}$$

The 10 kg of mixture has Pb = 19%, Fe = 26%, Cu = 36% and Mn = 19%.

[Return to Question 1 \(see page 80\)](#)

5.3.2 Solution 2: Chemical Connectivity

Firstly we are asked to draw up connectivity matrices for SF_6 , ethane and diborane. We note that although ethane and diborane have the similar empirical formulae their connectivities are *very* different.

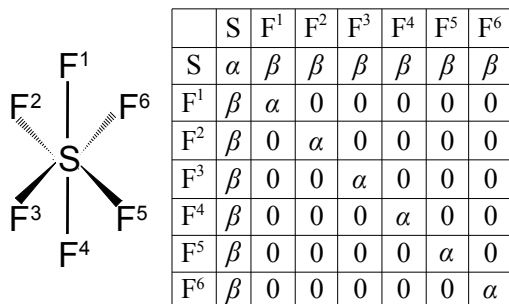

$$\begin{pmatrix} \alpha & \beta & \beta & \beta & \beta & \beta & \beta \\ \beta & \alpha & 0 & 0 & 0 & 0 & 0 \\ \beta & 0 & \alpha & 0 & 0 & 0 & 0 \\ \beta & 0 & 0 & \alpha & 0 & 0 & 0 \\ \beta & 0 & 0 & 0 & \alpha & 0 & 0 \\ \beta & 0 & 0 & 0 & 0 & \alpha & 0 \\ \beta & 0 & 0 & 0 & 0 & 0 & \alpha \end{pmatrix}$$

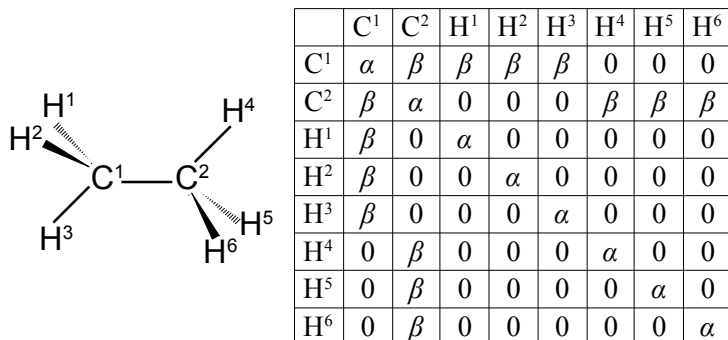

$$\begin{pmatrix} \alpha & \beta & \beta & \beta & \beta & 0 & 0 & 0 \\ \beta & \alpha & 0 & 0 & 0 & \beta & \beta & \beta \\ \beta & 0 & \alpha & 0 & 0 & 0 & 0 & 0 \\ \beta & 0 & 0 & \alpha & 0 & 0 & 0 & 0 \\ \beta & 0 & 0 & 0 & \alpha & 0 & 0 & 0 \\ 0 & \beta & 0 & 0 & 0 & \alpha & 0 & 0 \\ 0 & \beta & 0 & 0 & 0 & 0 & \alpha & 0 \\ 0 & \beta & 0 & 0 & 0 & 0 & 0 & \alpha \end{pmatrix}$$



How will people travel in the future, and how will goods be transported? What resources will we use, and how many will we need? The passenger and freight traffic sector is developing rapidly, and we provide the impetus for innovation and movement. We develop components and systems for internal combustion engines that operate more cleanly and more efficiently than ever before. We are also pushing forward technologies that are bringing hybrid vehicles and alternative drives into a new dimension – for private, corporate, and public use. The challenges are great. We deliver the solutions and offer challenging jobs.

www.schaeffler.com/careers

SCHAEFFLER



Click on the ad to read more

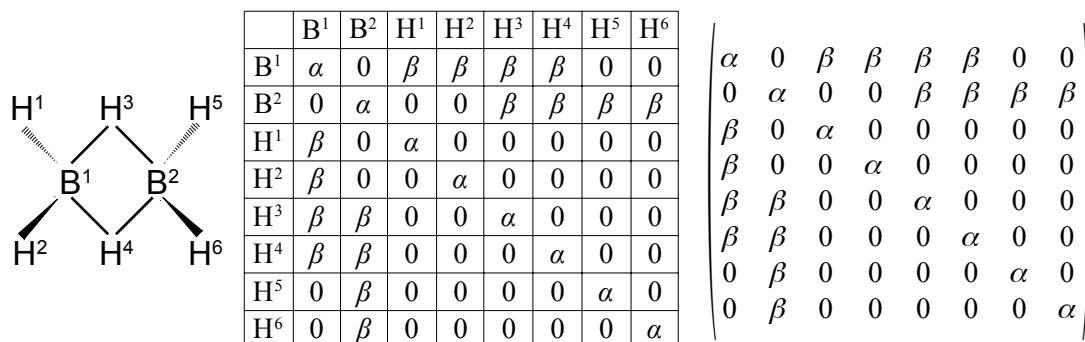

Secondly, we are asked to draw up connectivity matrices for the unsaturated acyclic molecules and radicals ethene, allyl radical, butadiene, and hexatriene; and then their cyclic counterparts cyclopropenyl radical, cyclobutadiene and benzene. For all these species we will *consider only the carbon atoms*.

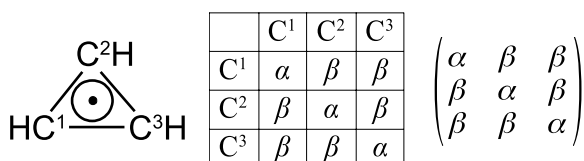
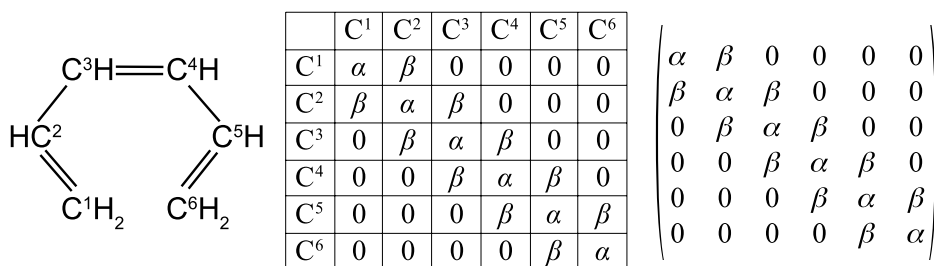
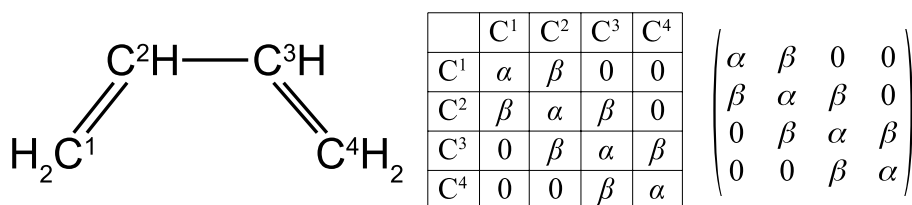
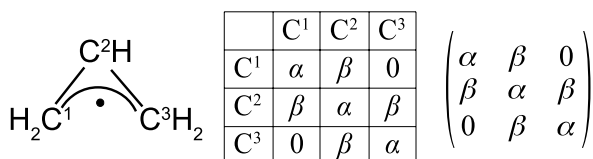
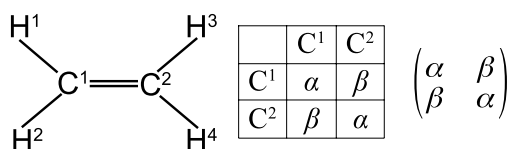

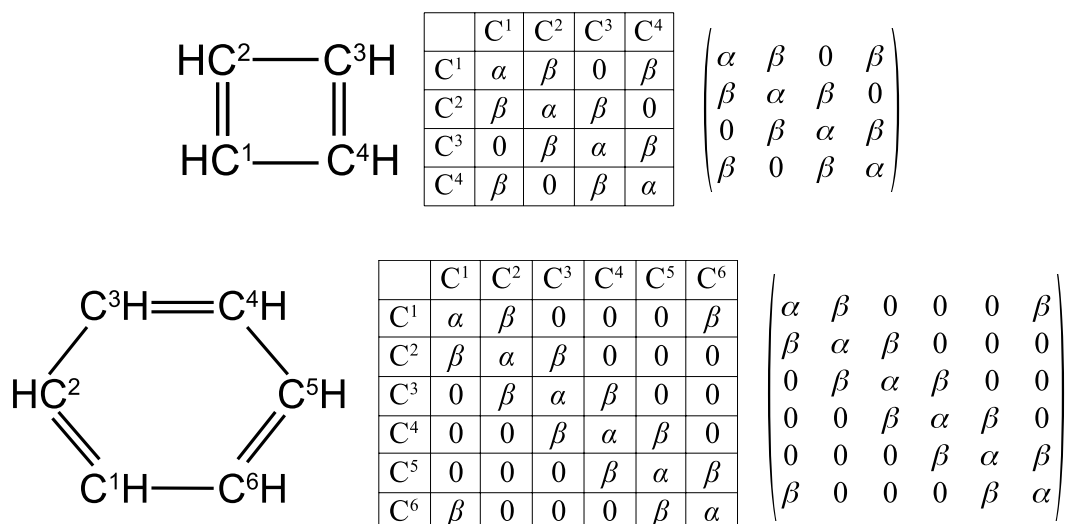

[Return to Question 2 \(see page 81\)](#)

5.3.3 Solution 3: Molecular Symmetry Operations, Linear Transformations

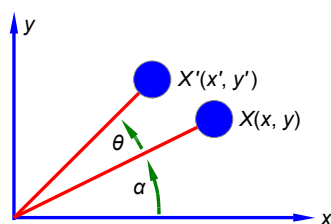

Figure 5.16: rotation in a plane.

If the distance from the origin is r then for X and X' we have,

$$X \ (x = r \cos \alpha \quad y = r \sin \alpha) \quad X' \ (x' = r \cos(\alpha + \theta) \quad y' = r \sin(\alpha + \theta))$$

Expanding the double angles using the trig formula $\cos(A + B) = (\cos A \cos B) - (\sin A \sin B)$ and the formula for $\sin(A + B) = (\sin A \cos B) + (\cos A \sin B)$. For X' we have,

$$x' = r(\cos \alpha \cos \theta - \sin \alpha \sin \theta) \quad y' = r(\sin \alpha \cos \theta + \cos \alpha \sin \theta)$$

Noting that the *change* from (x, y) to (x', y') only involves the value of θ (as r and α are constants) we can put the *change* due to the rotation, *i.e.* the transformation, into a matrix form,

$$\begin{pmatrix} x' \\ y' \end{pmatrix} = \begin{pmatrix} x \cos \theta - y \sin \theta \\ x \sin \theta + y \cos \theta \end{pmatrix} \quad \begin{pmatrix} x' \\ y' \end{pmatrix} = \begin{pmatrix} \cos \theta & -\sin \theta \\ \sin \theta & \cos \theta \end{pmatrix} \begin{pmatrix} x \\ y \end{pmatrix}$$

The rotation matrix around the z -axis \mathbf{R} is

$$\mathbf{R} = \begin{pmatrix} \cos \theta & -\sin \theta \\ \sin \theta & \cos \theta \end{pmatrix}$$

Extending the rotation matrix \mathbf{R} to the more general anticlockwise rotation about the z -axis of a point with coordinates (x, y, z)

$$\begin{pmatrix} x' \\ y' \\ z' \end{pmatrix} = \begin{pmatrix} x \cos \theta & -y \sin \theta & z \times 0 \\ x \sin \theta & y \cos \theta & z \times 0 \\ x \times 0 & y \times 0 & z \times 1 \end{pmatrix} \quad \begin{pmatrix} x' \\ y' \\ z' \end{pmatrix} = \begin{pmatrix} \cos \theta & -\sin \theta & 0 \\ \sin \theta & \cos \theta & 0 \\ 0 & 0 & 1 \end{pmatrix} \begin{pmatrix} x \\ y \\ z \end{pmatrix}$$

$$\mathbf{R} = \begin{pmatrix} \cos \theta & -\sin \theta & 0 \\ \sin \theta & \cos \theta & 0 \\ 0 & 0 & 1 \end{pmatrix}$$

[Return to Question 3 \(see page 83\)](#)

**STUDY FOR YOUR MASTER'S DEGREE
IN THE CRADLE OF SWEDISH ENGINEERING**

Chalmers University of Technology conducts research and education in engineering and natural sciences, architecture, technology-related mathematical sciences and nautical sciences. Behind all that Chalmers accomplishes, the aim persists for contributing to a sustainable future – both nationally and globally.

Visit us on Chalmers.se or **Next Stop Chalmers** on facebook.

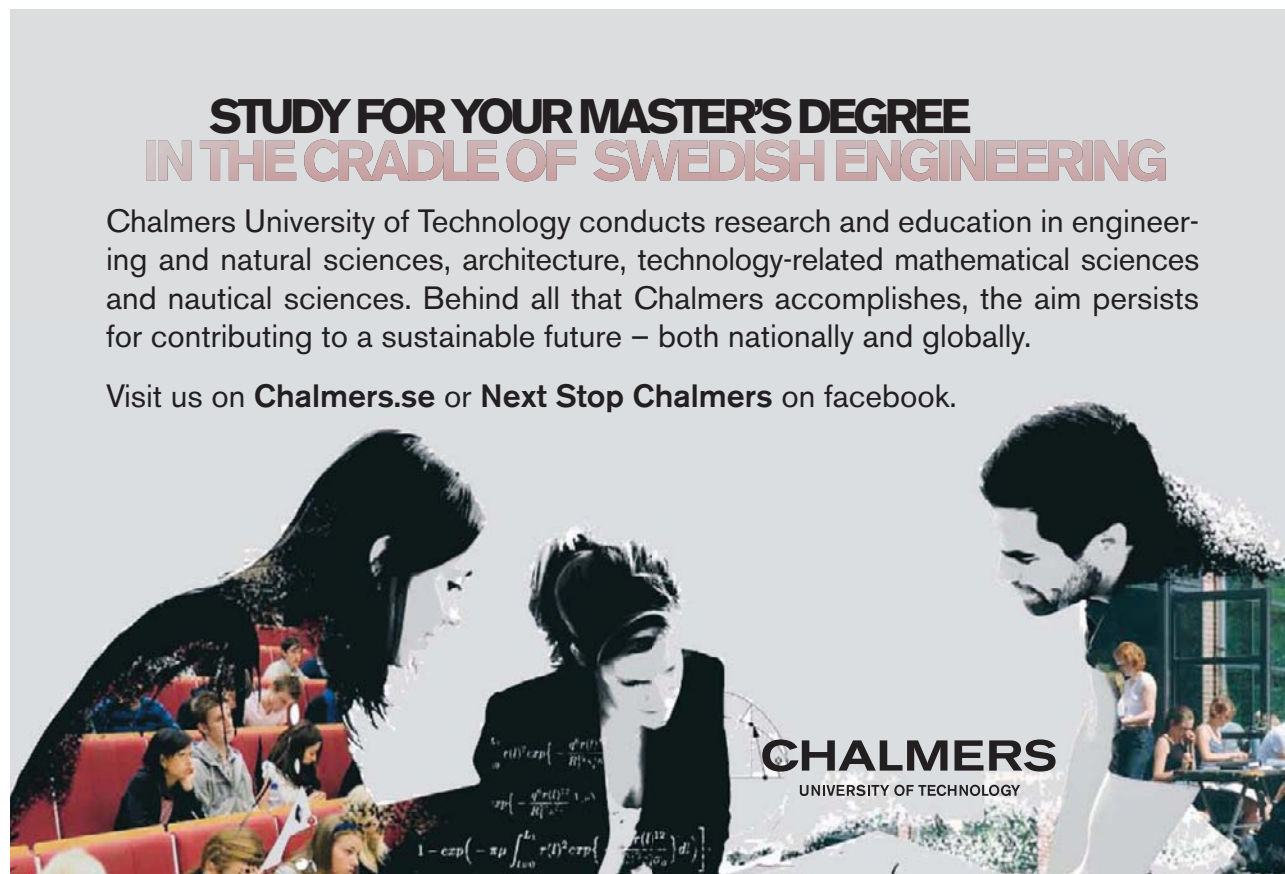

CHALMERS
UNIVERSITY OF TECHNOLOGY

5.3.4 Solution 4: Three-Dimensional Molecular Symmetry Operations

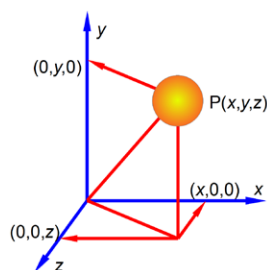

Figure 5.17: three-dimensional Cartesian coordinates.

We have already looked at the solution for the rotation around the z axis in section 5.3.3 above, Now anticlockwise rotation about the x axis by an angle θ is.

$$\begin{pmatrix} x' \\ y' \\ z' \end{pmatrix} = \begin{pmatrix} 1 & 0 & 0 \\ 0 & \cos \theta & -\sin \theta \\ 0 & \sin \theta & \cos \theta \end{pmatrix} \begin{pmatrix} x \\ y \\ z \end{pmatrix}$$

and anticlockwise rotation about the y -axis by an angle θ is,

$$\begin{pmatrix} x' \\ y' \\ z' \end{pmatrix} = \begin{pmatrix} \cos \theta & 0 & \sin \theta \\ 0 & 1 & 0 \\ -\sin \theta & 0 & \cos \theta \end{pmatrix} \begin{pmatrix} x \\ y \\ z \end{pmatrix}$$

Reflection in the xy plane only changes the z coordinate to $-z$

$$\begin{pmatrix} x' \\ y' \\ z' \end{pmatrix} = \begin{pmatrix} 1 & 0 & 0 \\ 0 & 1 & 0 \\ 0 & 0 & -1 \end{pmatrix} \begin{pmatrix} x \\ y \\ z \end{pmatrix}$$

and reflection in the yz plane only changes the x coordinate to $-x$

$$\begin{pmatrix} x' \\ y' \\ z' \end{pmatrix} = \begin{pmatrix} -1 & 0 & 0 \\ 0 & 1 & 0 \\ 0 & 0 & 1 \end{pmatrix} \begin{pmatrix} x \\ y \\ z \end{pmatrix}$$

and the final reflection, in the zx plane only changes the y coordinate to $-y$

$$\begin{pmatrix} x' \\ y' \\ z' \end{pmatrix} = \begin{pmatrix} 1 & 0 & 0 \\ 0 & -1 & 0 \\ 0 & 0 & 1 \end{pmatrix} \begin{pmatrix} x \\ y \\ z \end{pmatrix}$$

Inversion through the origin will change all three coordinates to their negative values

$$\begin{pmatrix} x' \\ y' \\ z' \end{pmatrix} = \begin{pmatrix} -1 & 0 & 0 \\ 0 & -1 & 0 \\ 0 & 0 & -1 \end{pmatrix} \begin{pmatrix} x \\ y \\ z \end{pmatrix}$$

[Return to Question 4 \(see page 84\)](#)

5.3.5 Solution 5: Molecular Structure Analysis of Cyclic Molecules

The C-C distance in benzene is 1.40 Å with the angle between neighbouring C-atoms of $360^\circ/6 = 60^\circ$. So neighbouring C-atoms form an isosceles triangle with the origin, so half the angle and half the bond distance gives us a right angle triangle with the hypotenuse of $(1.40 \text{ Å}/2)/\sin(60^\circ/2) = 1.40 \text{ Å}$. In Fig. 5.18 the coordinates of C¹ are (1.40, 0, 0) after dropping the units for clarity.

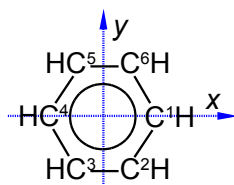

Figure 5.18: benzene carbon atoms.

C² is symmetry related to C¹ as a rotation around the z-axis of 300°

$$\begin{pmatrix} C^2 x \\ C^2 y \\ C^2 z \end{pmatrix} = \begin{pmatrix} \cos 300 & -\sin 300 & 0 \\ \sin 300 & \cos 300 & 0 \\ 0 & 0 & 1 \end{pmatrix} \begin{pmatrix} 1.40 \\ 0 \\ 0 \end{pmatrix} = \begin{pmatrix} (1.40 \times \cos 300) - (0 \times \sin 300) + (0 \times 0) \\ (1.40 \times \sin 300) + (0 \times \cos 300) + (0 \times 0) \\ (1.40 \times 0) + (0 \times 0) + (0 \times 1) \end{pmatrix} = \begin{pmatrix} 0.70 \\ -1.21 \\ 0 \end{pmatrix}$$

C³ is a reflection in the yz plane of C² and only changes the x coordinate of C² to $-x$

$$\begin{pmatrix} C^3 x \\ C^3 y \\ C^3 z \end{pmatrix} = \begin{pmatrix} -1 & 0 & 0 \\ 0 & 1 & 0 \\ 0 & 0 & 1 \end{pmatrix} \begin{pmatrix} 0.70 \\ -1.21 \\ 0 \end{pmatrix} = \begin{pmatrix} -0.70 \\ -1.21 \\ 0 \end{pmatrix}$$

C⁴ is a reflection in the yz plane of C¹ and only changes the x coordinate of C¹ to $-x$

$$\begin{pmatrix} C^4 x \\ C^4 y \\ C^4 z \end{pmatrix} = \begin{pmatrix} -1 & 0 & 0 \\ 0 & 1 & 0 \\ 0 & 0 & 1 \end{pmatrix} \begin{pmatrix} 1.40 \\ 0 \\ 0 \end{pmatrix} = \begin{pmatrix} -1.40 \\ 0 \\ 0 \end{pmatrix}$$

C⁵ is an inversion through the origin of C² will change all three coordinates to their negative values

$$\begin{pmatrix} C^5 x \\ C^5 y \\ C^5 z \end{pmatrix} = \begin{pmatrix} -1 & 0 & 0 \\ 0 & -1 & 0 \\ 0 & 0 & -1 \end{pmatrix} \begin{pmatrix} 0.70 \\ -1.21 \\ 0 \end{pmatrix} = \begin{pmatrix} -0.70 \\ 1.21 \\ 0 \end{pmatrix}$$

C⁶ is a reflection in the zx plane of C² and only changes the y coordinate of C² to $-y$

$$\begin{pmatrix} C^6 x \\ C^6 y \\ C^6 z \end{pmatrix} = \begin{pmatrix} 1 & 0 & 0 \\ 0 & -1 & 0 \\ 0 & 0 & 1 \end{pmatrix} \begin{pmatrix} 0.70 \\ -1.21 \\ 0 \end{pmatrix} = \begin{pmatrix} 0.70 \\ 1.21 \\ 0 \end{pmatrix}$$

The C-C distance in the cyclopentadiene anion is 1.40 Å with the angle between neighbouring C-atoms of $360^\circ/5 = 72^\circ$. So neighbouring C-atoms form an isosceles triangle with the origin, so half the angle and half the bond distance gives us a right angle triangle with the hypotenuse of $(1.40 \text{ Å}/2)/\sin(72^\circ/2) = 1.19 \text{ Å}$. So in Fig. 5.19 C¹ has the coordinates (1.19, 0, 0) after dropping the units for clarity.

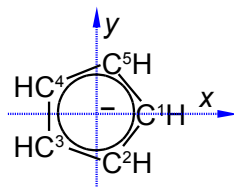

Figure 5.19: cyclopentadiene anion carbon atoms.

C² is obtained by an anticlockwise rotation around the z-axis of $360^\circ - 72^\circ = 288^\circ$,

$$\begin{pmatrix} C^2 x \\ C^2 y \\ C^2 z \end{pmatrix} = \begin{pmatrix} \cos 288 & -\sin 288 & 0 \\ \sin 288 & \cos 288 & 0 \\ 0 & 0 & 1 \end{pmatrix} \begin{pmatrix} 1.19 \\ 0 \\ 0 \end{pmatrix} = \begin{pmatrix} (1.19 \times \cos 288) - (0 \times \sin 288) + (0 \times 0) \\ (1.19 \times \sin 288) + (0 \times \cos 288) + (0 \times 0) \\ (1.19 \times 0) + (0 \times 0) + (0 \times 1) \end{pmatrix} = \begin{pmatrix} 0.37 \\ -1.13 \\ 0 \end{pmatrix}$$

C³ is an anticlockwise rotation of C² by 288° around the z-axis,

$$\begin{pmatrix} C^3 x \\ C^3 y \\ C^3 z \end{pmatrix} = \begin{pmatrix} \cos 288 & -\sin 288 & 0 \\ \sin 288 & \cos 288 & 0 \\ 0 & 0 & 1 \end{pmatrix} \begin{pmatrix} 0.37 \\ -1.13 \\ 0 \end{pmatrix} = \begin{pmatrix} (0.37 \times \cos 288) + (1.13 \times \sin 288) + (0 \times 0) \\ (0.37 \times \sin 288) - (1.13 \times \cos 288) + (0 \times 0) \\ (0.37 \times 0) - (1.13 \times 0) + (0 \times 1) \end{pmatrix} = \begin{pmatrix} -0.96 \\ -0.70 \\ 0 \end{pmatrix}$$



Scholarships



Ln.u.se

Open your mind to new opportunities

With 31,000 students, Linnaeus University is one of the larger universities in Sweden. We are a modern university, known for our strong international profile. Every year more than 1,600 international students from all over the world choose to enjoy the friendly atmosphere and active student life at Linnaeus University. Welcome to join us!

Linnaeus University

Sweden

Bachelor programmes in
Business & Economics | Computer Science/IT | Design | Mathematics

Master programmes in
Business & Economics | Behavioural Sciences | Computer Science/IT | Cultural Studies & Social Sciences | Design | Mathematics | Natural Sciences | Technology & Engineering

Summer Academy courses

C^4 is a reflection in the zx plane of C^3 which only changes the y coordinate,

$$\begin{pmatrix} C^4 x \\ C^4 y \\ C^4 z \end{pmatrix} = \begin{pmatrix} 1 & 0 & 0 \\ 0 & -1 & 0 \\ 0 & 0 & 1 \end{pmatrix} \begin{pmatrix} -0.96 \\ -0.70 \\ 0 \end{pmatrix} = \begin{pmatrix} -0.96 \\ 0.70 \\ 0 \end{pmatrix}$$

C^5 is a reflection in the zx plane of C^2 and only changes the y coordinate,

$$\begin{pmatrix} C^5 x \\ C^5 y \\ C^5 z \end{pmatrix} = \begin{pmatrix} 1 & 0 & 0 \\ 0 & -1 & 0 \\ 0 & 0 & 1 \end{pmatrix} \begin{pmatrix} 0.37 \\ -1.13 \\ 0 \end{pmatrix} = \begin{pmatrix} 0.37 \\ 1.13 \\ 0 \end{pmatrix}$$

The take home message is that without the use of matrix algebra of symmetry operations these structural problems in Chemistry would involve some complicated non-trivial trig calculations, I know which I would rather do!

[Return to Question 5 \(see page 85\)](#)

5.3.6 Solution 6: Methane Molecular Structure Analysis

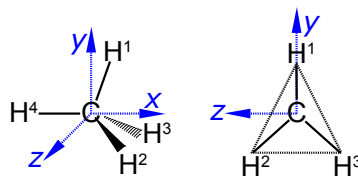

Figure 5.20: methane structure.

In Fig. 5.20 the coordinates of C^1 are $(0, 0, 0)$ and the coordinates of H^4 are $(-1.091, 0, 0)$.

H^1 can be found by a *clockwise* (or negative) rotation of 109.47° about the z -axis of H^4 .

$$\begin{pmatrix} H^1 x \\ H^1 y \\ H^1 z \end{pmatrix} = \begin{pmatrix} \cos(-109.47) & -\sin(-109.47) & 0 \\ \sin(-109.47) & \cos(-109.47) & 0 \\ 0 & 0 & 1 \end{pmatrix} \begin{pmatrix} -1.091 \\ 0 \\ 0 \end{pmatrix} = \begin{pmatrix} -1.091 \times \cos(-109.47) \\ -1.091 \times \sin(-109.47) \\ 0 \end{pmatrix} = \begin{pmatrix} 0.3636 \\ 1.0286 \\ 0 \end{pmatrix}$$

H^2 and H^3 can be found by a rotation of $+120^\circ$ and -120° , respectively, about the x -axis of atom H^1 .

$$\begin{pmatrix} H^2 x \\ H^2 y \\ H^2 z \end{pmatrix} = \begin{pmatrix} 1 & 0 & 0 \\ 0 & \cos 120 & -\sin 120 \\ 0 & \sin 120 & \cos 120 \end{pmatrix} \begin{pmatrix} 0.3636 \\ 1.0286 \\ 0 \end{pmatrix} = \begin{pmatrix} 0.3636 \\ 1.0286 \times \cos 120 \\ 1.0286 \times \sin 120 \end{pmatrix} = \begin{pmatrix} 0.3636 \\ -0.5143 \\ 0.8908 \end{pmatrix}$$

$$\begin{pmatrix} H^3 x \\ H^3 y \\ H^3 z \end{pmatrix} = \begin{pmatrix} 1 & 0 & 0 \\ 0 & \cos(-120) & -\sin(-120) \\ 0 & \sin(-120) & \cos(-120) \end{pmatrix} \begin{pmatrix} 0.3636 \\ 1.0286 \\ 0 \end{pmatrix} = \begin{pmatrix} 0.3636 \\ 1.0286 \times \cos(-120) \\ 1.0286 \times \sin(-120) \end{pmatrix} = \begin{pmatrix} 0.3636 \\ -0.5143 \\ -0.8908 \end{pmatrix}$$

[Return to Question 6 \(see page 85\)](#)

5.3.7 Solution 7: Ethane Molecular Structure Analysis

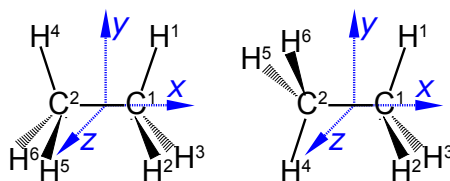

Figure 5.21: ethane structure.

The C-C bond length is 1.541 Å and C-H bond length is 1.091 Å and all bond angles are tetrahedral 109.47°. For the eclipsed conformation (on the left of Fig. 5.21) the coordinates of C¹, H¹, H², and H³ are similar to methane (Solution 6) except the x coordinates are increased by 1.541 Å/2 = 0.7705 Å. The coordinates of C², H⁴, H⁵, and H⁶ are related to C¹, H¹, H², and H³ by reflection in the mirror in the yz plane *i.e.* the x coordinates change sign.

	x	y	z		x	y	z
C ¹	0.7705	0.0000	0.0000	C ²	-0.7705	0.0000	0.0000
H ¹	1.1341	1.0286	0.0000	H ⁴	-1.1341	1.0286	0.0000
H ²	1.1341	-0.5143	0.8908	H ⁵	-1.1341	-0.5143	0.8908
H ³	1.1341	-0.5143	-0.8908	H ⁶	-1.1341	-0.5143	-0.8908

Figure 5.22: ethane eclipsed coordinates.

The coordinates of C¹, C², H¹, H², and H³ of the staggered conformation of ethane (on the right in Fig. 5.21) are identical to those above in Fig. 5.22. The coordinates of H⁴, H⁵, and H⁶ are related to H¹, H², and H³ by inversion through the centre of symmetry, *i.e.* the coordinates of H⁴, H⁵, and H⁶ are the same as H¹, H², and H³ but with an inversion of their sign.

	x	y	z		x	y	z
C ¹	0.7705	0.0000	0.0000	C ²	-0.7705	0.0000	0.0000
H ¹	1.1341	1.0286	0.0000	H ⁴	-1.1341	-1.0286	0.0000
H ²	1.1341	-0.5143	0.8908	H ⁵	-1.1341	0.5143	-0.8908
H ³	1.1341	-0.5143	-0.8908	H ⁶	-1.1341	0.5143	0.8908

Figure 5.23: ethane staggered coordinates.

[Return to Question 7 \(see page 85\)](#)

5.3.8 Solution 8: Chemistry and Simultaneous Equations

There is a linear relationship between the Celsius and Fahrenheit temperature scales that for two different temperatures which may then be written in matrix form and substituting for the freezing point and normal boiling points of water gives,

$$\begin{aligned} T_F^1 &= mT_C^1 + C \\ T_F^2 &= mT_C^2 + C \end{aligned}$$

$$\begin{pmatrix} T_F^1 \\ T_F^2 \end{pmatrix} = \begin{pmatrix} T_C^1 & 1 \\ T_C^2 & 1 \end{pmatrix} \begin{pmatrix} m \\ C \end{pmatrix} \quad \begin{pmatrix} 32 \\ 212 \end{pmatrix} = \begin{pmatrix} 0 & 1 \\ 100 & 1 \end{pmatrix} \begin{pmatrix} m \\ C \end{pmatrix}$$

Writing the matrix equation in the standard way for simultaneous equations gives,

$$\begin{pmatrix} 0 & 1 \\ 100 & 1 \end{pmatrix} \begin{pmatrix} m \\ C \end{pmatrix} = \begin{pmatrix} 32 \\ 212 \end{pmatrix}$$

This is in the form $Ax = b$ and using the matrix algebra described previously, the determinant $|A|$, the matrix of cofactors C , the transpose of the matrix of cofactors C^T , and the inverse A^{-1} are, respectively,

$$|A| = \begin{vmatrix} 0 & 1 \\ 100 & 1 \end{vmatrix} = 0 \times 1 - 1 \times 100 = -100$$



e-learning for kids

- The number 1 MOOC for Primary Education
- Free Digital Learning for Children 5-12
- 15 Million Children Reached

About e-Learning for Kids Established in 2004, e-Learning for Kids is a global nonprofit foundation dedicated to fun and free learning on the Internet for children ages 5 - 12 with courses in math, science, language arts, computers, health and environmental skills. Since 2005, more than 15 million children in over 190 countries have benefitted from eLessons provided by EFK! An all-volunteer staff consists of education and e-learning experts and business professionals from around the world committed to making difference. eLearning for Kids is actively seeking funding, volunteers, sponsors and courseware developers; get involved! For more information, please visit www.e-learningforkids.org.

$$\mathbf{C} = \begin{pmatrix} +1 & -100 \\ -1 & +0 \end{pmatrix}$$

$$\mathbf{C}^T = \begin{pmatrix} +1 & -1 \\ -100 & +0 \end{pmatrix}$$

$$\mathbf{A}^{-1} = \frac{1}{|\mathbf{A}|} \mathbf{C}^T = \frac{1}{-100} \begin{pmatrix} +1 & -1 \\ -100 & +0 \end{pmatrix}$$

The solution for the unknowns m and C is obtained from $\mathbf{x} = \mathbf{A}^{-1} \mathbf{b}$

$$\begin{pmatrix} m \\ C \end{pmatrix} = \frac{1}{-100} \begin{pmatrix} 1 & -1 \\ -100 & 0 \end{pmatrix} \begin{pmatrix} 32 \\ 212 \end{pmatrix} = \frac{1}{-100} \begin{pmatrix} (1 \times 32) - (1 \times 212) \\ (-100 \times 32) + (0 \times 212) \end{pmatrix} = \frac{1}{-100} \begin{pmatrix} -180 \\ -3200 \end{pmatrix} = \begin{pmatrix} 1.8 \\ 32 \end{pmatrix}$$

$$T_F = 1.8 T_C + 32$$

[Return to Question 8 \(see page 86\)](#)

5.3.9 Solution 9: The Speed of Chemical Reactions

$$\begin{pmatrix} \ln k_1 \\ \ln k_2 \end{pmatrix} = \begin{pmatrix} 1 & -1/T_1 \\ 1 & -1/T_2 \end{pmatrix} \begin{pmatrix} \ln A \\ E_a/R \end{pmatrix}$$

In the standard matrix form $\mathbf{A} \mathbf{x} = \mathbf{b}$ this is rearranged to

$$\begin{pmatrix} 1 & -1/T_1 \\ 1 & -1/T_2 \end{pmatrix} \begin{pmatrix} \ln A \\ E_a/R \end{pmatrix} = \begin{pmatrix} \ln k_1 \\ \ln k_2 \end{pmatrix}$$

Substituting in the experimental values without units for clarity, and for the moment working to extra significant figures to avoid rounding errors,

$$\begin{pmatrix} 1 & -1/600 \\ 1 & -1/716 \end{pmatrix} \begin{pmatrix} \ln A \\ E_a/R \end{pmatrix} = \begin{pmatrix} \ln 0.385 \\ \ln 16.0 \end{pmatrix}$$

$$\begin{pmatrix} 1 & -1.6667 \times 10^{-3} \\ 1 & -1.3966 \times 10^{-3} \end{pmatrix} \begin{pmatrix} \ln A \\ E_a/R \end{pmatrix} = \begin{pmatrix} -0.9545 \\ 2.7726 \end{pmatrix}$$

$$|\mathbf{A}| = (-1.3966 \times 10^{-3}) - (-1.6667 \times 10^{-3}) = 2.701 \times 10^{-4}$$

$$\mathbf{C} = \begin{pmatrix} +(-1.3966 \times 10^{-3}) & -1 \\ -(-1.6667 \times 10^{-3}) & +1 \end{pmatrix} = \begin{pmatrix} -1.3966 \times 10^{-3} & -1 \\ +1.6667 \times 10^{-3} & +1 \end{pmatrix}$$

$$\mathbf{C}^T = \begin{pmatrix} -1.3966 \times 10^{-3} & +1.6667 \times 10^{-3} \\ -1 & +1 \end{pmatrix}$$

Solving for the unknowns matrix \mathbf{x} using,

$$\mathbf{x} = \mathbf{A}^{-1} \mathbf{b} \quad \mathbf{x} = \frac{1}{|\mathbf{A}|} \mathbf{C}^T \mathbf{b}$$

$$\mathbf{x} = \frac{1}{2.701 \times 10^{-4}} \begin{pmatrix} -1.3966 \times 10^{-3} & +1.6667 \times 10^{-3} \\ -1 & +1 \end{pmatrix} \begin{pmatrix} -0.9545 \\ 2.7726 \end{pmatrix}$$

$$\mathbf{x} = \frac{1}{2.701 \times 10^{-4}} \begin{pmatrix} 1.3331 \times 10^{-3} + 4.6211 \times 10^{-3} \\ 0.9545 + 2.7726 \end{pmatrix} = \frac{1}{2.701 \times 10^{-4}} \begin{pmatrix} 5.9542 \times 10^{-3} \\ 3.7271 \end{pmatrix}$$

$$\mathbf{x} = \begin{pmatrix} 22.044 \\ 13799 \end{pmatrix}$$

Thus $\ln A = 22.044$ and the pre-exponential factor to three significant figures is,

$$A = 3.75 \times 10^9 \text{ L mol}^{-1} \text{ s}^{-1}$$

$E_a/R = 13,799$ so $E_a = 13,799 \times 8.314 \text{ J mol}^{-1} \text{ K}^{-1} = 114.72 \times 10^3 \text{ J mol}^{-1} \text{ K}^{-1}$ or in the conventional units and to three significant figures,

$$E_a = 115 \text{ kJ mol}^{-1}$$

[Return to Question 9 \(see page 86\)](#)

5.3.10 Solution 10: Chemical Analysis of Well Separated Spectral Regions

For the binary mixture then writing this in matrix form, entering the student's lab results (without units for clarity), rearranging the matrix equation into the standard simultaneous equations form gives $\mathbf{A} \mathbf{x} = \mathbf{b}$ and solving this by matrix algebra

$$\begin{aligned} A_{285} &= \epsilon_{X285} l[X] + \epsilon_{Y285} l[Y] \\ A_{338} &= \epsilon_{X338} l[X] + \epsilon_{Y338} l[Y] \end{aligned}$$

$$\begin{pmatrix} A_{285} \\ A_{338} \end{pmatrix} = \begin{pmatrix} \epsilon_{X285} & \epsilon_{Y285} \\ \epsilon_{X338} & \epsilon_{Y338} \end{pmatrix} \begin{pmatrix} c_X \\ c_Y \end{pmatrix}$$

$$\begin{pmatrix} 0.952 \\ 0.553 \end{pmatrix} = \begin{pmatrix} 16441 & 3872 \\ 3993 & 6423 \end{pmatrix} \begin{pmatrix} C_X \\ C_Y \end{pmatrix}$$

$$\begin{pmatrix} 16441 & 3872 \\ 3993 & 6423 \end{pmatrix} \begin{pmatrix} C_X \\ C_Y \end{pmatrix} = \begin{pmatrix} 0.952 \\ 0.553 \end{pmatrix}$$

$$|A| = 16441(6423) - 3872(3993) = 1.056 \times 10^8 - 1.546 \times 10^7 = 9.014 \times 10^7$$

$$C = \begin{pmatrix} +6423 & -3993 \\ -3872 & +16441 \end{pmatrix} \quad C^T = \begin{pmatrix} +6423 & -3872 \\ -3993 & +16441 \end{pmatrix}$$

$$x = A^{-1}b \quad x = \frac{1}{|A|}C^Tb$$

$$x = \frac{1}{9.014 \times 10^7} \begin{pmatrix} +6423 & -3872 \\ -3993 & +16441 \end{pmatrix} \begin{pmatrix} 0.952 \\ 0.553 \end{pmatrix} = \frac{1}{9.014 \times 10^7} \begin{pmatrix} (0.952 \times 6423) + (0.553 \times -3872) \\ (0.952 \times -3993) + (0.553 \times 16441) \end{pmatrix}$$

$$x = \frac{1}{9.014 \times 10^7} \begin{pmatrix} 6115 - 2141 \\ -3801 + 9092 \end{pmatrix} = \frac{1}{9.014 \times 10^7} \begin{pmatrix} 3974 \\ 5291 \end{pmatrix}$$

$$x = \begin{pmatrix} 4.4087 \times 10^{-5} \\ 5.8698 \times 10^{-5} \end{pmatrix}$$

The unknown concentrations from the well-separated spectral regions are to three significant figures

$$c_x = 4.41 \times 10^{-5} \text{ mol L}^{-1} \text{ and } c_y = 5.87 \times 10^{-5} \text{ mol L}^{-1}$$

.....Alcatel-Lucent 

www.alcatel-lucent.com/careers



What if you could build your future and create the future?

One generation's transformation is the next's status quo. In the near future, people may soon think it's strange that devices ever had to be "plugged in." To obtain that status, there needs to be "The Shift".

 [Click on the ad to read more](#)

Where there is a substantial overlap of the spectra of the pure components (Fig. 5.24) we cannot use matrix algebra methods to solve the simultaneous equations. They are solved by a linear least squares spreadsheet using the Solver algorithm (Parker 2013, section 1.1.2), (Blanco *et al* 1989), and (Harris 2007, p 402).

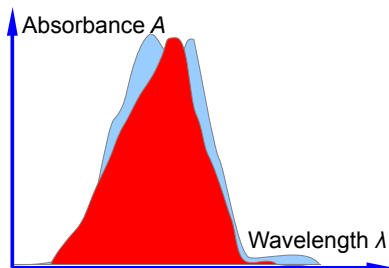

Figure 5.24: spectra of pure components with substantial overlap

[Return to Question 10 \(see page 86\)](#)

5.3.11 Solution 11: Chemical Analysis of the Spectra of Three or More Components

This is the same fundamental problem as above, extended to a ternary mixture. It is assumed that the concentrations of the dyes are low and their absorbances at a range of wavelengths are additive, *i.e.* they are each dominant in at a given wavelength and they don't interact chemically with one another. First let us try the manual matrix approach.

$$\begin{aligned} A_{455} &= \epsilon_{\text{TB}455} l c_{\text{TB}} + \epsilon_{\text{STB}455} l c_{\text{STB}} + \epsilon_{\text{MTB}455} l c_{\text{MTB}} \\ A_{485} &= \epsilon_{\text{TB}485} l c_{\text{TB}} + \epsilon_{\text{STB}485} l c_{\text{STB}} + \epsilon_{\text{MTB}485} l c_{\text{MTB}} \\ A_{545} &= \epsilon_{\text{TB}545} l c_{\text{TB}} + \epsilon_{\text{STB}545} l c_{\text{STB}} + \epsilon_{\text{MTB}545} l c_{\text{MTB}} \end{aligned}$$

Writing this in matrix form, entering the student's lab results (without units for clarity) and then rearranging the matrix equation into the standard simultaneous equations form we have

$$\begin{pmatrix} A_{455} \\ A_{485} \\ A_{545} \end{pmatrix} = \begin{pmatrix} \epsilon_{\text{TB}455} & \epsilon_{\text{STB}455} & \epsilon_{\text{MTB}455} \\ \epsilon_{\text{TB}485} & \epsilon_{\text{STB}485} & \epsilon_{\text{MTB}485} \\ \epsilon_{\text{TB}545} & \epsilon_{\text{STB}545} & \epsilon_{\text{MTB}545} \end{pmatrix} \begin{pmatrix} c_{\text{TB}} \\ c_{\text{STB}} \\ c_{\text{MTB}} \end{pmatrix}$$

$$\begin{pmatrix} 0.4745 \\ 0.3394 \\ 0.3095 \end{pmatrix} = \begin{pmatrix} 4800 & 11100 & 18900 \\ 7350 & 11200 & 11800 \\ 36400 & 13900 & 4450 \end{pmatrix} \begin{pmatrix} c_{\text{TB}} \\ c_{\text{STB}} \\ c_{\text{MTB}} \end{pmatrix}$$

$$\begin{pmatrix} 4800 & 11100 & 18900 \\ 7350 & 11200 & 11800 \\ 36400 & 13900 & 4450 \end{pmatrix} \begin{pmatrix} c_{\text{TB}} \\ c_{\text{STB}} \\ c_{\text{MTB}} \end{pmatrix} = \begin{pmatrix} 0.4745 \\ 0.3394 \\ 0.3095 \end{pmatrix}$$

but trying to solve this manually gives us *problems*, here is the determinant

$$\begin{aligned}
 |A| = & +4800(11200 \times 4450 - 11800 \times 13900) - 11100(7350 \times 4450 - 11800 \times 36400) \\
 & + 18900(7350 \times 13900 - 11200 \times 36400) - 7350(11100 \times 4450 - 18900 \times 13900) \\
 & + 11200(4800 \times 4450 - 18900 \times 36400) - 11800(4800 \times 13900 - 11100 \times 36400) \\
 & + 36400(11100 \times 11800 - 18900 \times 11200) - 13900(4800 \times 4450 - 18900 \times 36400) \\
 & + 4450(4800 \times 11200 - 11100 \times 7350)
 \end{aligned}$$

The above determinant is *awful!* The manual method of matrix algebra for this type of numerical matrix equation has been useful for initial learning purposes also for small 2x2 matrices and matrices with “sparse” numbers. The manual method is also useful for *examination* questions where computers are not allowed! However, the manual method is a problem when finding the determinant and the matrix of cofactors for 3x3 or larger matrices and for those with numerically “rich” matrices as in the one above. It is *slow, clumsy* and prone to *errors*. Let’s see how easy it is to use a spreadsheet and the inversion of matrix **A**, and then directly use $\mathbf{x} = \mathbf{A}^{-1}\mathbf{b}$ which is shown in Fig. 5.25.

$$\mathbf{x} = \frac{1}{|A|} \mathbf{C}^T \mathbf{b} \quad \mathbf{x} = \mathbf{A}^{-1} \mathbf{b}$$

	A	B	C	D	E	F	G
1		TB	STB	MTB	Mixture	Mixture	
2	λ/nm	$\epsilon_x/\text{L mol}^{-1} \text{cm}^{-1}$	$\epsilon_y/\text{L mol}^{-1} \text{cm}^{-1}$	$\epsilon_x/\text{L mol}^{-1} \text{cm}^{-1}$	<i>A</i>	Concn.	
3	455	4800	11100	18900	0.4745	3.5230E-06	← c_{TB}
4	485	7350	11200	11800	0.3394	6.5143E-06	← c_{STB}
5	545	36400	13900	4450	0.3095	2.0385E-05	← c_{MTB}

Figure 5.25: matrix algebra with a spreadsheet.

The wavelengths are not used in the calculation, they are just helpful reminders. The matrix **A** is in the array B3:D5 and the matrix **b** is in array E3:E5. We select the three empty cell F3:F5 and type in the formula window the following array formula

$$=MMULT(MINVERSE(B3:D5),E3:E5)$$

Do *not* press enter or return as it is an array function rather than a simple Maths function. Instead on a PC press Shift+Control+Return or on Mac Command+Return and the solution appear in the array F3:F5. The spreadsheet commands are MMULT for matrix multiplication the two matrices. The first matrix is the inverse of **A** (*i.e.* \mathbf{A}^{-1}) MINVERSE and the second is the absorbances of the mixture, **b**.

$$c_{\text{TB}} = 3.52 \times 10^{-6} \text{ mol L}^{-1} \quad c_{\text{STB}} = 6.51 \times 10^{-6} \text{ mol L}^{-1} \quad c_{\text{MTB}} = 2.04 \times 10^{-5} \text{ mol L}^{-1}$$

[Return to Question 11 \(see page 88\)](#)

6 Week 6: Chemistry, Matrices and Hückel Theory

Understanding the spectroscopy, electronic properties and the chemical reactions of conjugated π -systems is important for biological, medicinal and industrial reasons. A “simple” approach is Hückel molecular orbital theory where the molecular orbital energies and wavefunctions are obtained by using matrix algebra. I am using the example of ethene to explain in some detail the process, as often there are some steps omitted when presented in lectures or textbooks which don't help our understanding of what is happening. Hang in there it is much easier to solve them in practice but I am starting by giving the background quantum mechanics.



Nido

- Luxurious accommodation**
- Central zone 1 & 2 locations**
- Meet hundreds of international students**
- BOOK NOW and get a £100 voucher from voucherexpress**

Nido Student Living - London

Visit www.NidoStudentLiving.com/Bookboon for more info.

+44 (0)20 3102 1060



Finding the *energies* (eigenvalues) and the *wavefunctions* (eigenfunctions) of the allowed quantum states turns up frequently in Chemistry. One of the first approaches to investigating the electronic states of unsaturated organic molecules with *conjugated* π -systems is the Hückel MO (HMO) method. The Hückel *approximation* only considers the π -orbitals and ignores the σ -orbitals, the σ skeleton is already assumed in the HMO approach. The reason for spending so much time on this “qualitative” theory as opposed to the more sophisticated and computer based methods of *ab initio* or semi-empirical theories is that we can really get at the “heart” of Hückel theory, otherwise quantum chemistry will be much more challenging and more of a “black box” for most people. Hückel theory also gives us a clear insight into the molecular orbitals of a very important range of molecules.

Using ethene as example I will work through it to show the details. The wavefunction Ψ for the π -orbitals are made up by a linear combination of the two $2p$ atomic orbitals (AOs) ϕ_1 and ϕ_2 of the two carbon atoms contributing to the π -bond.

$$\Psi = c_1\phi_1 + c_2\phi_2$$

where c_1 and c_2 tell us the relative contributions of these two p AOs. Different wavefunctions can have different values for these coefficients. The Hückel method starts with the Schrödinger equation,

$$H\Psi = E\Psi$$

where H is the Hamiltonian or energy operator applied to the wavefunction Ψ and E the energy of the molecular orbital. As we shall soon see, Hückel method expresses the energy E as the sum of two terms called α (the energy of an electron in a $2p$ -orbital) and β (the interaction energy between two neighbouring p orbitals). Both α and β are negative quantities and at the moment unknown but importantly have become *independent* of any particular molecule. Therefore we can compare different molecules with one another. Substituting for Ψ gives

$$c_1 H \phi_1 + c_2 H \phi_2 = c_1 E \phi_1 + c_2 E \phi_2$$

If this is multiplied by ϕ_1^* (the complex conjugate of ϕ_1) and integrated over all space, and separately if the equation above is multiplied by ϕ_2^* and integrated we get a pair of simultaneous equations for ethene,

$$\begin{aligned} c_1 \int \phi_1^* H \phi_1 d v + c_2 \int \phi_1^* H \phi_2 d v &= c_1 E \int \phi_1^* \phi_1 d v + c_2 E \int \phi_1^* \phi_2 d v \\ c_1 \int \phi_2^* H \phi_1 d v + c_2 \int \phi_2^* H \phi_2 d v &= c_1 E \int \phi_2^* \phi_1 d v + c_2 E \int \phi_2^* \phi_2 d v \end{aligned}$$

If the Hamiltonian integrals (on the left hand side) are written H_{ij} for shorthand and the overlap integral (on the right hand side) are written as S_{ij} these two simultaneous equations may be rewritten as,

$$\begin{aligned} c_1 H_{11} + c_2 H_{12} &= c_1 E S_{11} + c_2 E S_{12} \\ c_1 H_{21} + c_2 H_{22} &= c_1 E S_{21} + c_2 E S_{22} \end{aligned}$$

This pair of simultaneous equations may be rearranged to a clearer form

$$\begin{aligned}(H_{11} - E S_{11})c_1 + (H_{12} - E S_{12})c_2 &= 0 \\ (H_{21} - E S_{21})c_1 + (H_{22} - E S_{22})c_2 &= 0\end{aligned}$$

Hückel then made the following approximations in order to be able solve the simultaneous equations by hand

$$\begin{aligned}H_{11} = H_{22} = \alpha & \quad H_{12} = H_{21} = \beta \\ S_{11} = S_{22} = 1 & \quad S_{12} = S_{21} = 0\end{aligned}$$

and $H_{ij} = 0$ for any *non-neighbouring* π -carbon atoms (which are not present in ethene) and then writing the pair of simultaneous equations in matrix form gives us the Hückel matrix equation.

$$\begin{pmatrix} \alpha - E & \beta \\ \beta & \alpha - E \end{pmatrix} \begin{pmatrix} c_1 \\ c_2 \end{pmatrix} = \begin{pmatrix} 0 \\ 0 \end{pmatrix} \quad \text{The Hückel Matrix}$$

The first matrix on the left looks very similar to our connectivity matrices developed earlier (sections 5.2.2 and 5.3.2) but with α in the connectivity matrix replaced by $\alpha - E$ in the Hückel matrix. For non-trivial solutions of the Hückel matrix, the corresponding Hückel secular determinant must be equal to 0.

$$\begin{vmatrix} \alpha - E & \beta \\ \beta & \alpha - E \end{vmatrix} = 0 \quad \text{The Hückel Secular Determinant}$$

To find the eigenvalues (allowed energies) we must solve the Hückel secular determinant for ethene. It is mathematically convenient to divide each element of the Hückel determinant by β

$$\begin{vmatrix} \frac{\alpha - E}{\beta} & 1 \\ 1 & \frac{\alpha - E}{\beta} \end{vmatrix} = 0$$

Making the substitution $x = (\alpha - E)/\beta$ gives us a very simple determinant to solve for the ethene eigenvalues,

$$\begin{aligned}\begin{vmatrix} x & 1 \\ 1 & x \end{vmatrix} &= 0 \\ x^2 - 1 = 0 & \quad x = \pm 1 \quad \frac{\alpha - E}{\beta} = \pm 1\end{aligned}$$

$$E_1 = \alpha + \beta \quad \text{and} \quad E_2 = \alpha - \beta \quad \text{The HOMO-LUMO energy gap is } (E_1 - E_2) = 2\beta$$

Remembering that both α and β are negative values, the highest occupied molecular orbital (HOMO) has an energy of $E_1 = \alpha + \beta$ for $x = -1$ and is π bonding. The lowest unoccupied molecular orbital (LUMO) has an eigenvalue $E_2 = \alpha - \beta$ for $x = +1$ and is π^* anti-bonding. The MOs are labelled with a subscript 1, 2, ... with increasing energy.

To find the eigenvectors (wavefunctions) we must solve the Hückel matrix for ethene for each of the allowed energies (eigenvalues). Substituting for the energy of the HOMO $E_1 = \alpha + \beta$ gives $(\alpha - E_1) = -\beta$,

$$\begin{pmatrix} \alpha - E_1 & \beta \\ \beta & \alpha - E_1 \end{pmatrix} \begin{pmatrix} c_1 \\ c_2 \end{pmatrix} = \begin{pmatrix} 0 \\ 0 \end{pmatrix} \quad \begin{pmatrix} -\beta & \beta \\ \beta & -\beta \end{pmatrix} \begin{pmatrix} c_1 \\ c_2 \end{pmatrix} = \begin{pmatrix} 0 \\ 0 \end{pmatrix} \quad \begin{aligned} -\beta c_1 + \beta c_2 &= 0 \\ +\beta c_1 - \beta c_2 &= 0 \end{aligned}$$

The pair of simultaneous equations implies that $c_1 = c_2$. The coefficients are *normalized* (that is the total probability of finding the π -electron in the HOMO orbital must be unity) by making the sum of the coefficients squared equal to unity $c_1^2 + c_2^2 + \dots c_n^2 = 1$.

$$c_1^2 + c_2^2 = 1 \text{ and } c_1 = c_2 \quad \text{thus } c_1 = c_2 = \frac{1}{\sqrt{2}}$$

The HOMO eigenvector (wavefunction) for ethene and its eigenvalue (energy) from Hückel theory is,

$$\psi_1 = \frac{1}{\sqrt{2}} (\phi_1 + \phi_2) \quad E_1 = \alpha + \beta$$

SIMPLY CLEVER

ŠKODA



WE WILL TURN YOUR CV
INTO AN OPPORTUNITY
OF A LIFETIME

Do you like cars? Would you like to be a part of a successful brand?
As a constructor at ŠKODA AUTO you will put great things in motion. Things that will ease everyday lives of people all around Send us your CV. We will give it an entirely new new dimension.

Send us your CV on
www.employerforlife.com

Substituting the LUMO eigenvalue $E_2 = \alpha - \beta$ then $(\alpha - E_2) = \beta$ into the Hückel matrix gives

$$\begin{pmatrix} \alpha - E_2 & \beta \\ \beta & \alpha - E_2 \end{pmatrix} \begin{pmatrix} c_1 \\ c_2 \end{pmatrix} = \begin{pmatrix} 0 \\ 0 \end{pmatrix} \quad \begin{pmatrix} \beta & \beta \\ \beta & \beta \end{pmatrix} \begin{pmatrix} c_1 \\ c_2 \end{pmatrix} = \begin{pmatrix} 0 \\ 0 \end{pmatrix} \quad \begin{aligned} \beta c_1 + \beta c_2 &= 0 \\ \beta c_1 + \beta c_2 &= 0 \end{aligned}$$

which means that $c_1 = -c_2$ and normalizing the coefficients

$$c_1^2 + c_2^2 = 1 \text{ and } c_1 = -c_2 \quad \text{thus } c_1 = \frac{1}{\sqrt{2}} \text{ and } c_2 = -\frac{1}{\sqrt{2}}$$

The LUMO eigenvector (wavefunction) for ethene and its eigenvalue (energy) from Hückel theory is,

$$\psi_2 = \frac{1}{\sqrt{2}} (\phi_1 - \phi_2) \quad E_2 = \alpha - \beta$$

The MO diagrams for the Hückel approximation for ethene are shown in Fig. 6.1.

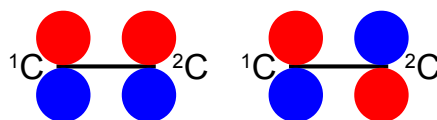

Figure 6.1: HOMO and LUMO of ethene.

where the red volume are the positive-phase lobes and the blue the negative-phase lobes of the π bonds. On the left is the π bond and on the right the π anti-bond. The MO diagrams will use the same colour convention in this book. The MO energy diagram is shown below,

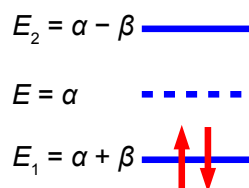

Figure 6.2: Hückel MO energy diagram for ethene.

For the 2 π -electrons of ethene their total energy is $2(\alpha + \beta) = (2\alpha + 2\beta)$ which compared with 2 isolated $2p$ -electrons of energy 2α , means that Hückel theory shows that ethene is stabilized by 2β .

6.1 Week 6 Tutorial Questions

6.1.1 Question 1: HMO Theory for the Allyl Cation, Radical, and Anion

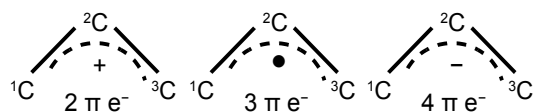

Figure 6.3: allyl cation, radical and anion.

- (a) Write down the Hückel secular determinant for the acyclic three C-atoms in terms of x , where $x = (\alpha - E)/\beta$. (b) Solve the secular determinant for x and then rewrite the solution in terms of $(\alpha - E)/\beta$ and so find the three allowed quantized energies (eigenvalues). (c) Evaluate the normalized wavefunction (eigenvector) for each energy (eigenvalue). (d) Which of the wavefunctions is the HOMO, LUMO or SOMO (singly occupied MO) as appropriate, for each of the allyl cation, radical and anion molecules?

[Jump to Solution 1 \(see page 112\)](#)

6.1.2 Question 2: HMO Theory for Cyclopropenyl Cation, Radical and Anion

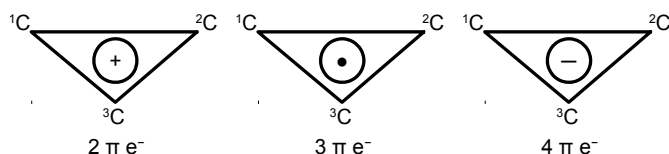

Figure 6.4: cyclopropenyl cation, radical and anion.

- (a) Write down the Hückel secular determinant for the cyclic three C-atoms in terms of x , where $x = (\alpha - E)/\beta$. (b) Solve the secular determinant for x and then rewrite the solution in terms of $(\alpha - E)/\beta$ and so find the three allowed quantized energies (eigenvalues). (c) Evaluate the normalized wavefunction (eigenvector) for each energy (eigenvalues). (d) Which of the wavefunctions is the HOMO, LUMO or SOMO as appropriate, for each of the cyclopropenyl cation, radical and anion molecules?

[Jump to Solution 2 \(see page 115\)](#)

6.1.3 Question 3: HMO Theory for 1,3-Butadiene

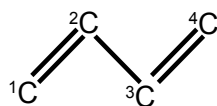

Figure 6.5: butadiene.

(a) Write down the Hückel secular determinant for the four C-atoms of butadiene in terms of x , where $x = (\alpha - E)/\beta$. (b) Solve the secular determinant for x and then rewrite the solutions in terms of $(\alpha - E)/\beta$ and so find the four allowed quantized energies (eigenvalues). (c) Evaluate the normalized wavefunction (eigenvector) for each energy (eigenvalues). (d) Which of the wavefunctions is the HOMO or LUMO?

[Jump to Solution 3 \(see page 118\)](#)

6.1.4 Question 4: HMO Theory for Cyclobutadiene

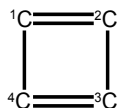

Figure 6.6: cyclobutadiene.

(a) Write down the Hückel secular determinant for the four C-atoms of cyclobutadiene in terms of x , where $x = (\alpha - E)/\beta$. (b) Solve the secular determinant for x and then rewrite the solution in terms of $(\alpha - E)/\beta$ and so find the allowed quantized energies (eigenvalues). (c) Evaluate the normalized wavefunction (eigenvector) for each energy (eigenvalues). (d) Which of the wavefunctions is the HOMO, a non-bonding NBMO or a LUMO for cyclobutadiene?

[Jump to Solution 4 \(see page 122\)](#)



UPPSALA
UNIVERSITET

Develop the tools we need for Life Science Masters Degree in Bioinformatics

Bioinformatics is the exciting field where biology, computer science, and mathematics meet.

We solve problems from biology and medicine using methods and tools from computer science and mathematics.

Read more about this and our other international masters degree programmes at www.uu.se/master



Click on the ad to read more

6.2 Week 6 Tutorial Solutions

6.2.1 Solution 1: HMO Theory for the Allyl Cation, Radical, and Anion

$$\begin{vmatrix} x & 1 & 0 \\ 1 & x & 1 \\ 0 & 1 & x \end{vmatrix} = 0$$

The solution of the secular determinant is,

$$x(x^2 - 1) - 1(x - 0) + 0(1 - 0) = 0 \quad x^3 - 2x = 0$$

$$x(x^2 - 2) = 0 \quad x = 0, \pm\sqrt{2}$$

There are 3 energy levels which have the eigenvalues below,

$$\begin{array}{lll} x = 0 & x = +\sqrt{2} & x = -\sqrt{2} \\ E = \alpha & E = (\alpha - \sqrt{2} \beta) & E = (\alpha + \sqrt{2} \beta) \end{array}$$

Since α and β are both have negative values so with increasing energy the eigenvalues are the following

$$E_1 = \alpha + \sqrt{2} \beta \quad E_2 = \alpha \quad E_3 = \alpha - \sqrt{2} \beta$$

To find the three eigenvectors (wavefunctions) corresponding to these three eigenvalues we must separately solve the Hückel matrix for allyl for each energy. For $E_1 = (\alpha + \sqrt{2} \beta)$ then $(\alpha - E_1) = -\sqrt{2} \beta$

$$\begin{pmatrix} \alpha - E_1 & \beta & 0 \\ \beta & \alpha - E_1 & \beta \\ 0 & \beta & \alpha - E_1 \end{pmatrix} \begin{pmatrix} c_1 \\ c_2 \\ c_3 \end{pmatrix} = \begin{pmatrix} 0 \\ 0 \\ 0 \end{pmatrix} \quad \begin{pmatrix} -\sqrt{2} \beta & \beta & 0 \\ \beta & -\sqrt{2} \beta & \beta \\ 0 & \beta & -\sqrt{2} \beta \end{pmatrix} \begin{pmatrix} c_1 \\ c_2 \\ c_3 \end{pmatrix} = \begin{pmatrix} 0 \\ 0 \\ 0 \end{pmatrix}$$

Which gives us the three simultaneous equations below when the matrices are multiplied out,

$$\begin{aligned} -\sqrt{2} \beta c_1 + \beta c_2 &= 0 \\ \beta c_1 - \sqrt{2} \beta c_2 + \beta c_3 &= 0 \\ \beta c_2 - \sqrt{2} \beta c_3 &= 0 \end{aligned}$$

Subtracting the third equation from the first gives $c_1 = c_3$. From the first equation $c_2 = \sqrt{2} c_1$ and from the third equation $c_2 = \sqrt{2} c_3$ which when we normalize the coefficients using $c_1^2 + c_2^2 + c_3^2 = 1$ gives

$$c_1 = \frac{1}{2} \quad c_2 = \frac{1}{\sqrt{2}} \quad c_3 = \frac{1}{2}$$

$$\psi_1 = \frac{\phi_1}{2} + \frac{\phi_2}{\sqrt{2}} + \frac{\phi_3}{2} \quad E_1 = \alpha + \sqrt{2} \beta$$

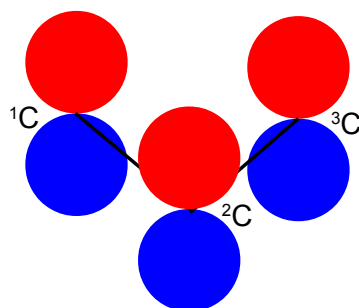

Figure 6.7: ψ_1 of the allyl system (not to scale).

Substituting into the Hückel matrix for allyl with $E_2 = \alpha$ then $(\alpha - E_2) = 0$

$$\begin{pmatrix} \alpha - E_2 & \beta & 0 \\ \beta & \alpha - E_2 & \beta \\ 0 & \beta & \alpha - E_2 \end{pmatrix} \begin{pmatrix} c_1 \\ c_2 \\ c_3 \end{pmatrix} = 0 \quad \begin{pmatrix} 0 & \beta & 0 \\ \beta & 0 & \beta \\ 0 & \beta & 0 \end{pmatrix} \begin{pmatrix} c_1 \\ c_2 \\ c_3 \end{pmatrix} = 0 \quad \begin{matrix} \beta c_2 = 0 \\ \beta c_1 + \beta c_3 = 0 \\ \beta c_2 = 0 \end{matrix}$$

From the first and third simultaneous equations $c_2 = 0$, and from second equation, $c_1 = -c_3$

If the coefficients are normalized, then $c_1^2 + c_2^2 + c_3^2 = 1$ then,

$$c_1 = \frac{1}{\sqrt{2}} \quad c_2 = 0 \quad c_3 = -\frac{1}{\sqrt{2}}$$

$$\psi_2 = \frac{\phi_1}{\sqrt{2}} - \frac{\phi_3}{\sqrt{2}} \quad E_2 = \alpha$$

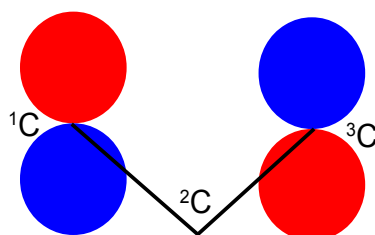

Figure 6.8: ψ_2 of the allyl system (not to scale).

Substituting into the Hückel matrix for allyl with $E_3 = \alpha - \sqrt{2} \beta$ then $(\alpha - E_3) = \sqrt{2} \beta$

$$\begin{pmatrix} \alpha - E_3 & \beta & 0 \\ \beta & \alpha - E_3 & \beta \\ 0 & \beta & \alpha - E_3 \end{pmatrix} \begin{pmatrix} c_1 \\ c_2 \\ c_3 \end{pmatrix} = 0 \quad \begin{pmatrix} \sqrt{2} \beta & \beta & 0 \\ \beta & \sqrt{2} \beta & \beta \\ 0 & \beta & \sqrt{2} \beta \end{pmatrix} \begin{pmatrix} c_1 \\ c_2 \\ c_3 \end{pmatrix} = 0 \quad \begin{matrix} \sqrt{2} \beta c_1 + \beta c_2 = 0 \\ \beta c_1 + \sqrt{2} \beta c_2 + \beta c_3 = 0 \\ \beta c_2 + \sqrt{2} \beta c_3 = 0 \end{matrix}$$

Subtracting the third from the first simultaneous equations $c_1 = c_3$; from the first equation $c_2 = -\sqrt{2} c_1$; from the third equation $c_2 = -\sqrt{2} c_3$ thus when the coefficients are normalised, then $c_1^2 + c_2^2 + c_3^2 = 1$ we have,

$$c_1 = \frac{1}{2} \quad c_2 = -\frac{1}{\sqrt{2}} \quad c_3 = \frac{1}{2}$$

$$\psi_3 = \frac{\phi_1}{2} - \frac{\phi_2}{\sqrt{2}} + \frac{\phi_3}{2} \quad E_3 = \alpha - \sqrt{2} \beta$$

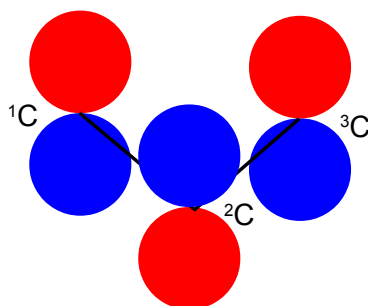

Figure 6.9: ψ_3 of the allyl system (not to scale).

UNIVERSITY OF COPENHAGEN



Copenhagen Master of Excellence

Copenhagen Master of Excellence are two-year master degrees taught in English at one of Europe's leading universities

Come to Copenhagen - *and aspire!*

Apply now at
www.come.ku.dk



cultural studies

religious studies

science

Fig. 6.10 shows the MO energy diagrams for the three allyl species.

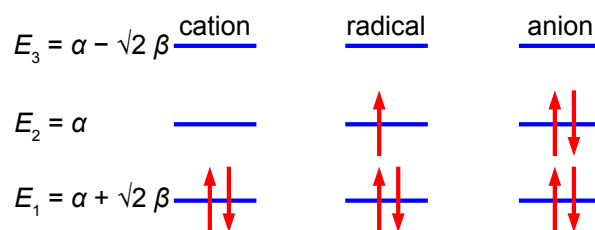

Figure 6.10: MO energy diagram for allyl cation, radical and anion.

In the allyl cation $\text{CH}_2=\text{CH}-\text{CH}_2^+$ with 2 π -electrons, then ψ_1 is the HOMO and ψ_2 is the LUMO. In the allyl radical $\text{CH}_2=\text{CH}-\text{CH}_2^\bullet$ with 3 π -electrons, then ψ_1 has 2 π -electrons and ψ_2 is the SOMO with 1 π -electron and ψ_3 is the LUMO. In the allyl anion $\text{CH}_2=\text{CH}-\text{CH}_2^-$ with 4 π -electrons, then ψ_1 has 2 π -electrons and ψ_2 is the HOMO with 2 π -electrons and ψ_3 is the LUMO.

[Return to Question 1 \(see page 110\)](#)

6.2.2 Solution 2: HMO Theory for Cyclopropenyl Cation, Radical and Anion

The cyclic species differs from the linear three carbon species in that *each* ring C-atom is bonded to two other C-atoms. Thus by inspection, put $x (\alpha - E)/\beta$ on the diagonal elements and 1 for the elements representing connected atoms in the secular determinant

$$\begin{vmatrix} x & 1 & 1 \\ 1 & x & 1 \\ 1 & 1 & x \end{vmatrix} = 0$$

$$x(x^2 - 1) - 1(x - 1) + 1(1 - x) = 0 \quad x^3 - x - x + 1 + 1 - x = 0 \quad x^3 - 3x + 2 = 0$$

This is a cubic equation and by inspection $x = +1$ is a root of the cubic, hence $(x-1)$ is a factor of the cubic equation. We may find the other factor, which should be a quadratic, by long division and then find the roots of the quadratic using the quadratic formula.

$$\begin{array}{r} x^2 + x - 2 \\ x - 1 \overline{) x^3 - 3x + 2} \\ \underline{x^3 - x^2} \\ x^2 - 3x \\ \underline{x^2 - x} \\ -2x + 2 \\ \underline{-2x + 2} \\ 0 + 0 \end{array}$$

The quadratic factor $(x^2+x-2) = 0$ is solved as $(x-1)(x+2) = 0$ or if you prefer by using the quadratic formula. The cyclopropenyl molecules each have three eigenvalues of which two are identical (degenerate) and in increasing order of energy they are

$$x = \frac{\alpha - E}{\beta} = -2 \quad x = \frac{\alpha - E}{\beta} = +1 \quad x = \frac{\alpha - E}{\beta} = +1$$

$$E_1 = \alpha + 2\beta \quad E_2 = \alpha - \beta \quad E_3 = \alpha - \beta$$

The eigenvectors (wavefunctions) are obtained by solving the Hückel matrix for cyclopropenyl molecules. For $E_1 = \alpha + 2\beta$, then $(\alpha - E_1) = -2\beta$,

$$\begin{pmatrix} -2\beta & \beta & \beta \\ \beta & -2\beta & \beta \\ \beta & \beta & -2\beta \end{pmatrix} \begin{pmatrix} c_1 \\ c_2 \\ c_3 \end{pmatrix} = 0 \quad \begin{aligned} -2\beta c_1 + \beta c_2 + \beta c_3 &= 0 \\ \beta c_1 - 2\beta c_2 + \beta c_3 &= 0 \\ \beta c_1 + \beta c_2 - 2\beta c_3 &= 0 \end{aligned}$$

From these simultaneous equations $2c_1 = c_2 + c_3$, $2c_2 = c_1 + c_3$, $2c_3 = c_1 + c_2$ and so we must have $c_1 = c_2 = c_3$, and normalizing the coefficients $c_1^2 + c_2^2 + c_3^2 = 1$ gives,

$$c_1 = c_2 = c_3 = \frac{1}{\sqrt{3}}$$

$$\psi_1 = \frac{\phi_1}{\sqrt{3}} + \frac{\phi_2}{\sqrt{3}} + \frac{\phi_3}{\sqrt{3}} \quad E_1 = \alpha + 2\beta$$

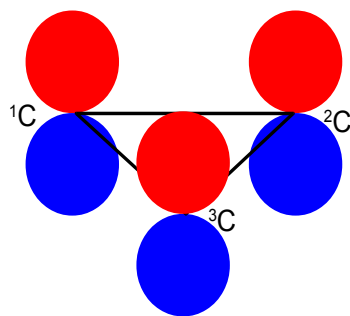

Figure 6.11: ψ_1 of the cyclopropenyl system (not to scale).

In Fig. 6.11 we see that the HMO ψ_1 is a delocalized π -bond involving all three C-atoms. The degenerate wavefunctions ψ_2 and ψ_3 are obtained from solving the Hückel matrix for $E_2 = (\alpha - \beta)$ and also $E_3 = (\alpha - \beta)$ so for $(\alpha - E_2) = \beta$ and $(\alpha - E_3) = \beta$

$$\begin{pmatrix} \beta & \beta & \beta \\ \beta & \beta & \beta \\ \beta & \beta & \beta \end{pmatrix} \begin{pmatrix} c_1 \\ c_2 \\ c_3 \end{pmatrix} = 0 \quad \begin{aligned} \beta c_1 + \beta c_2 + \beta c_3 &= 0 \\ \beta c_1 + \beta c_2 + \beta c_3 &= 0 \\ \beta c_1 + \beta c_2 + \beta c_3 &= 0 \end{aligned}$$

The two degenerate MOs do *not* give independent solutions for the coefficients and we are free to choose the first solution as long as it satisfies the secular equation $c_1 + c_2 + c_3 = 0$ above. For ψ_2 we can choose that $c_3 = 0$ and then $c_1 = -c_2$ after normalizing the coefficients $c_1^2 + c_2^2 + c_3^2 = 1$ we have $c_1 = -c_2 = 1/\sqrt{2}$

$$\psi_2 = \frac{\phi_1}{\sqrt{2}} - \frac{\phi_2}{\sqrt{2}} \quad E_2 = \alpha - \beta$$

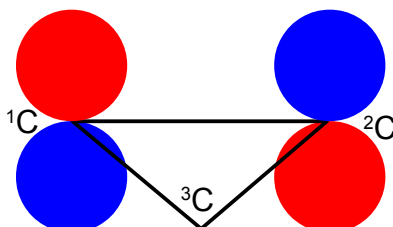

Figure 6.12: ψ_2 of the cyclopropenyl system (not to scale).

For ψ_2 we chose that $c_1 = -c_2$ then the other degenerate wavefunction ψ_3 *must* have $c_1 = +c_2$ so substituting this into the secular equation $c_1 + c_2 + c_3 = 0$ gives $c_3 = -2c_1 = -2c_2$. After normalizing the coefficients $c_1^2 + c_2^2 + c_3^2 = 1$ we have the ψ_3 wavefunction with $c_1 = c_2 = 1/\sqrt{6}$ and $c_3 = -2/\sqrt{6}$ and so,

$$\psi_3 = \frac{\phi_1}{\sqrt{6}} + \frac{\phi_2}{\sqrt{6}} - \frac{2\phi_3}{\sqrt{6}} \quad E_3 = \alpha - \beta$$

Brain power



Plug into The Power of Knowledge Engineering.
Visit us at www.skf.com/knowledge

By 2020, wind could provide one-tenth of our planet's electricity needs. Already today, SKF's innovative know-how is crucial to running a large proportion of the world's wind turbines.

Up to 25 % of the generating costs relate to maintenance. These can be reduced dramatically thanks to our systems for on-line condition monitoring and automatic lubrication. We help make it more economical to create cleaner, cheaper energy out of thin air.

By sharing our experience, expertise, and creativity, industries can boost performance beyond expectations. Therefore we need the best employees who can meet this challenge!

The Power of Knowledge Engineering



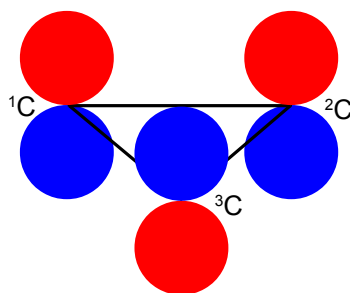

Figure 6.13: ψ_3 of the cyclopropenyl system (not to scale).

Fig. 6.14 shows the MO energy diagrams for the three cyclopropenyl molecules.

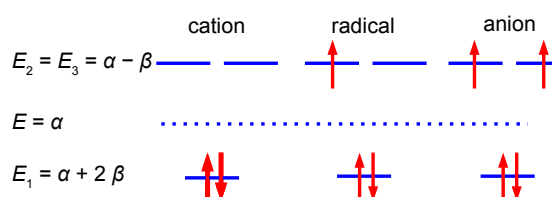

Figure 6.14: MO energy diagram for cyclopropenyl cation, radical and anion (not to scale).

The cyclopropenyl cation with two $2p$ electrons with a π -electron energy of $(2\alpha+4\beta)$ which compared with two isolated $2p$ electrons of energy 2α has a stabilization energy of $(2\alpha+4\beta) - 2\alpha = 4\beta$. As we will see it is the most stable of the three molecules also its π -electrons are delocalized (aromatic) agreeing with Hückel's $(4n+2)$ rule for monocyclic compounds.

The cyclopropenyl radical with three $2p$ electrons with a π -electrons energy of $2(\alpha+2\beta) + (\alpha - \beta) = (3\alpha + 3\beta)$ which compared with three isolated $2p$ electrons of energy 3α has a stabilization energy of $(3\alpha + 3\beta) - 3\alpha = 3\beta$.

The cyclopropenyl anion with four $2p$ electrons with with a π -electron energy of $2(\alpha+2\beta) + 2(\alpha-\beta) = (4\alpha+2\beta)$ which compared with four isolated $2p$ electrons of energy 4α has a stabilization energy of only $(4\alpha+2\beta)-4\alpha = 2\beta$. It is also a diradical in order to satisfy Hund's rule of maximum multiplicity.

[Return to Question 2 \(see page 110\)](#)

6.2.3 Solution 3: HMO Theory for 1,3-Butadiene

The solution of the Hückel determinant for butadiene is shown below.

$$\begin{vmatrix} x & 1 & 0 & 0 \\ 1 & x & 1 & 0 \\ 0 & 1 & x & 1 \\ 0 & 0 & 1 & x \end{vmatrix} = 0 \quad x \begin{vmatrix} x & 1 & 0 \\ 1 & x & 1 \\ 0 & 1 & x \end{vmatrix} - \begin{vmatrix} 1 & 1 & 0 \\ 0 & x & 1 \\ 0 & 1 & x \end{vmatrix} = 0$$

$$x^2(x^2-1) - x(x-0) - (x^2-1) = 0 \quad x^4 - 3x^2 + 1 = 0$$

To solve this quartic equation let us substitute $y = x^2$ and then use the quadratic equation to solve for y (using an excess of significant figures to reduce rounding errors) we have,

$$y^2 - 3y + 1 = 0 \quad y = \frac{3 \pm \sqrt{3^2 - 4 \times 1 \times 1}}{2 \times 1}$$

$$\begin{array}{cccc} y = +2.61803 & y = +0.38197 & & \\ x = +1.618 & x = -1.618 & x = +0.618 & x = -0.618 \end{array}$$

In increasing energy order the following eigenvalues (α and β are both negative quantities) are obtained

$$E_1 = \alpha + 1.618\beta \quad E_2 = \alpha + 0.618\beta \quad E_3 = \alpha - 0.618\beta \quad E_4 = \alpha - 1.618\beta$$

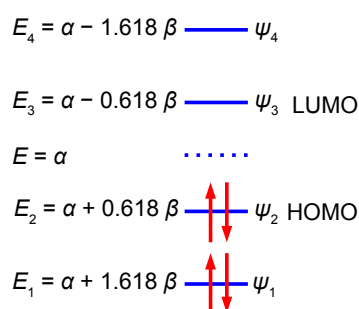

Figure 6.15: MO diagram for butadiene.

Although solving this particular 4×4 secular determinant gives a quartic equation which may be solved manually to find the eigenvalues, as we have done above, for larger matrices this is too cumbersome. Also carrying out the matrix multiplication to find the eigenvectors is less easy even for a 4×4 matrix. Secular determinants (the values of the column matrix on the right hand side being all equal to zero) *cannot* be solved using the spreadsheet method previously used in Week 5. Luckily we can generalize the results that we already have which gives us a method that is a distant relative of the particle in a box quantized systems.

For an acyclic conjugated hydrocarbon containing n carbon atoms in the chain,

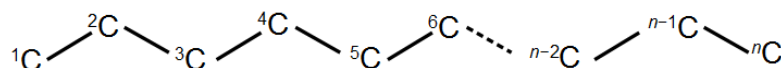

Figure 6.16: acyclic conjugated hydrocarbon of n carbon atoms in the chain.

The secular determinants all have the same form,

$$\begin{vmatrix} x & 1 & 0 & \dots & 0 & 0 & 0 \\ 1 & x & 1 & \dots & 0 & 0 & 0 \\ 0 & 1 & x & \dots & 0 & 0 & 0 \\ 0 & 0 & 0 & \dots & 1 & 0 & 0 \\ 0 & 0 & 0 & \dots & x & 1 & 0 \\ 0 & 0 & 0 & \dots & 1 & x & 1 \\ 0 & 0 & 0 & \dots & 0 & 1 & x \end{vmatrix} = 0$$

for which the eigenvalues (allowed energies) are,

$$E = \alpha + 2\beta \cos\left(\frac{\pi k}{n+1}\right)$$

where n = number of carbon atoms in the conjugated chain; k = quantum number identifying the MO
 $k = 1, 2, \dots, n$ with the cosine in radians.

$$E_1 = \alpha + 2\beta \cos\frac{\pi \times 1}{5} \quad E_2 = \alpha + 2\beta \cos\frac{\pi \times 2}{5} \quad E_3 = \alpha + 2\beta \cos\frac{\pi \times 3}{5} \quad E_4 = \alpha + 2\beta \cos\frac{\pi \times 4}{5}$$

$$E_1 = \alpha + 2\beta \times 0.809 \quad E_2 = \alpha + 2\beta \times 0.309 \quad E_3 = \alpha + 2\beta \times (-0.309) \quad E_4 = \alpha + 2\beta \times (-0.809)$$

$$E_1 = \alpha + 1.618\beta \quad E_2 = \alpha + 0.618\beta \quad E_3 = \alpha - 0.618\beta \quad E_4 = \alpha - 1.618\beta$$

These energies agree with our manual solutions found earlier. However, this generalized method becomes *really useful* for finding the wavefunctions (eigenvectors) for these larger Hückel matrices. We have four different Hückel matrices to solve, one for each energy. The coefficients are given by the following expression, note the proportionality as the coefficients have still to be normalized.

$$c_s \propto \sin\left(\frac{\pi k s}{n+1}\right)$$

Trust and responsibility

NNE and Pharmaplan have joined forces to create NNE Pharmaplan, the world's leading engineering and consultancy company focused entirely on the pharma and biotech industries.

Inés Aréizaga Esteva (Spain), 25 years old
 Education: Chemical Engineer

– You have to be proactive and open-minded as a newcomer and make it clear to your colleagues what you are able to cope. The pharmaceutical field is new to me. But busy as they are, most of my colleagues find the time to teach me, and they also trust me. Even though it was a bit hard at first, I can feel over time that I am beginning to be taken seriously and that my contribution is appreciated.



NNE Pharmaplan is the world's leading engineering and consultancy company focused entirely on the pharma and biotech industries. We employ more than 1500 people worldwide and offer global reach and local knowledge along with our all-encompassing list of services.
nnepharmaplan.com

nne pharmaplan®



where k and n have the same meaning as before and $s = \text{atom number } (1, 2, 3, \dots n)$ with the sine in radians.

$$\begin{array}{cccc}
 \psi_1 & \psi_2 & \psi_3 & \psi_4 \\
 c_1 \propto \sin \frac{\pi \times 1 \times 1}{5} & c_1 \propto \sin \frac{\pi \times 2 \times 1}{5} & c_1 \propto \sin \frac{\pi \times 3 \times 1}{5} & c_1 \propto \sin \frac{\pi \times 4 \times 1}{5} \\
 c_2 \propto \sin \frac{\pi \times 1 \times 2}{5} & c_2 \propto \sin \frac{\pi \times 2 \times 2}{5} & c_2 \propto \sin \frac{\pi \times 3 \times 2}{5} & c_2 \propto \sin \frac{\pi \times 4 \times 2}{5} \\
 c_3 \propto \sin \frac{\pi \times 1 \times 3}{5} & c_3 \propto \sin \frac{\pi \times 2 \times 3}{5} & c_3 \propto \sin \frac{\pi \times 3 \times 3}{5} & c_3 \propto \sin \frac{\pi \times 4 \times 3}{5} \\
 c_4 \propto \sin \frac{\pi \times 1 \times 4}{5} & c_4 \propto \sin \frac{\pi \times 2 \times 4}{5} & c_4 \propto \sin \frac{\pi \times 3 \times 4}{5} & c_4 \propto \sin \frac{\pi \times 4 \times 4}{5}
 \end{array}$$

$$\begin{array}{cccc}
 \psi_1 & \psi_2 & \psi_3 & \psi_4 \\
 c_1 \propto +0.5878 & c_1 \propto +0.9511 & c_1 \propto +0.9511 & c_1 \propto +0.9511 \\
 c_2 \propto +0.9511 & c_2 \propto +0.5878 & c_2 \propto -0.5878 & c_2 \propto -0.9511 \\
 c_3 \propto +0.9511 & c_3 \propto -0.5878 & c_3 \propto -0.5878 & c_3 \propto +0.9511 \\
 c_4 \propto +0.5878 & c_4 \propto -0.9511 & c_4 \propto +0.9511 & c_4 \propto -0.5878
 \end{array}$$

Normalizing the coefficients can be done in one step for as all four wavefunctions each have two coefficients squared of 0.5878^2 and two of 0.9511^2 ,

$$\left(\frac{0.5878}{N}\right)^2 + \left(\frac{0.9511}{N}\right)^2 + \left(\frac{0.9511}{N}\right)^2 + \left(\frac{0.5878}{N}\right)^2 = 1 \quad N^2 = 2.5002 \quad N = 1.5812$$

Dividing each of the non-normalized coefficients by $N = 1.5812$ gives us the normalized coefficients below.

$$\begin{array}{cccc}
 \psi_1 & \psi_2 & \psi_3 & \psi_4 \\
 c_1 = +0.3717 & c_1 = +0.6015 & c_1 = +0.6015 & c_1 = +0.6015 \\
 c_2 = +0.6015 & c_2 = +0.3717 & c_2 = -0.3717 & c_2 = -0.6015 \\
 c_3 = +0.6015 & c_3 = -0.3717 & c_3 = -0.3717 & c_3 = +0.6015 \\
 c_4 = +0.3717 & c_4 = -0.6015 & c_4 = +0.6015 & c_4 = -0.3717
 \end{array}$$

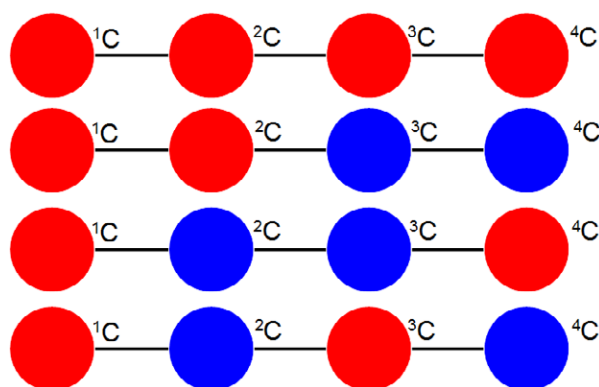

Figure 6.17: from the top, ψ_1 ψ_2 ψ_3 ψ_4 of butadiene looking down onto the $2p$ AOs (not to scale).

Fig. 6.17 illustrates the following, firstly, ψ_1 (HOMO-1) has the four π -electrons delocalized throughout the molecule. Secondly, ψ_2 (HOMO) is similar to our conventional drawing of two isolated π -bonds starting at carbon atoms 1 and 3 as in the full name 1,3-butadiene. Thirdly, ψ_3 (LUMO) has a single isolated double bond between atoms 2 and 3. Finally, ψ_4 (LUMO+1) has four isolated $2p$ atomic orbitals on the carbon atoms and is completely π -antibonding. The ground electronic state has the four $2p$ electrons occupying ψ_1 and ψ_2 with spins paired, see Fig. 6.15.

[Return to Question 3 \(see page 110\)](#)

6.2.4 Solution 4: HMO Theory for Cyclobutadiene

We will apply the general method for cyclic molecules to cyclobutadiene. The secular determinant is,

$$\begin{vmatrix} x & 1 & 0 & 1 \\ 1 & x & 1 & 0 \\ 0 & 1 & x & 1 \\ 1 & 0 & 1 & x \end{vmatrix} = 0$$

The determinant has an extra “1” in the (4,1) and the (1,4) corners compared to the acyclic butadiene, this is because of its “closed-up” ring structure. The general method for the energies (eigenvalues) of a cyclic conjugated hydrocarbon is slightly different from the acyclic version due to the slightly different secular determinant with the extra “1” in the $(n,1)$ and $(1,n)$ corners. The cyclic molecule solutions for the eigenvalues and eigenvectors are distantly related to the motion of a particle on a ring (Parker 2012, sections 4.1.3 and 4.2.3). The particle may travel clockwise or anticlockwise around the ring, thus there are two possible solutions for the eigenvectors.

$$\begin{vmatrix} x & 1 & 0 & \dots & 0 & 0 & 1 \\ 1 & x & 1 & \dots & 0 & 0 & 0 \\ 0 & 1 & x & \dots & 0 & 0 & 0 \\ 0 & 0 & 0 & \dots & 1 & 0 & 0 \\ 0 & 0 & 0 & \dots & x & 1 & 0 \\ 0 & 0 & 0 & \dots & 1 & x & 1 \\ 1 & 0 & 0 & \dots & 0 & 1 & x \end{vmatrix} = 0$$

$${}^k E = \alpha + 2\beta \cos\left(\frac{2\pi k}{n}\right)$$

The cosine is in radians where n = total number of carbon atoms forming the ring and k = quantum number identifying the MO where k may take the values,

$$k = 0, \pm 1, \pm 2, \dots, \pm \left(\frac{n}{2}\right) \text{ for } n = 4, 6, 8, \dots$$

$$k = 0, \pm 1, \pm 2, \dots, \pm \left(\frac{n-1}{2}\right) \text{ for } n = 3, 5, 7, \dots$$

Note that for “even” rings k runs to the *positive* value of $n/2$ but for “odd” rings that k runs to plus *and* minus $(n-1)/2$. For cyclobutadiene $n = 4$ and so k may take the values $k = 0, \pm 1$, and $+2$ only *i.e.* there are four solutions to the quartic equation in x derived from the 4×4 secular determinant.

$${}^0E = \alpha + 2\beta \cos \frac{2\pi \cdot 0}{4} \quad {}^1E = \alpha + 2\beta \cos \frac{2\pi \cdot 1}{4} \quad {}^{-1}E = \alpha + 2\beta \cos \frac{2\pi \cdot (-1)}{4} \quad {}^2E = \alpha + 2\beta \cos \frac{2\pi \cdot 2}{4}$$

$${}^0E = \alpha + 2\beta(1) \quad {}^1E = \alpha + 2\beta(0) \quad {}^{-1}E = \alpha + 2\beta(0) \quad {}^2E = \alpha + 2\beta(-1)$$

Relabelling the energies in the conventional way of increasing energy where α and β are negative quantities,

$$E_1 = \alpha + 2\beta \quad E_2 = \alpha \quad E_3 = \alpha \quad E_4 = \alpha - 2\beta$$

This e-book
is made with
SetaPDF





SETASIGN

PDF components for PHP developers

www.setasign.com

So there is one bonding, two degenerate non-bonding and one antibonding MOs for cyclobutadiene. There are four π -electrons, two of them are paired up in the ψ_1 bonding MO, the other two are placed one each in the two degenerate non-bonding MOs with their spins parallel because of Hund's rule of maximum multiplicity.

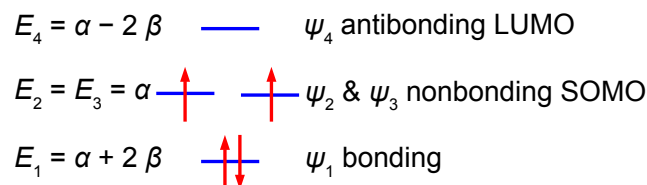

Figure 6.18: Hückel MO diagram for cyclobutadiene.

The π -electron energy is $2(\alpha + 2\beta) + 2\alpha = (4\alpha + 2\beta)$. The energy of two isolated double bonds (as in two ethene molecules) is $2(2\alpha + 2\beta) = (4\alpha + 4\beta)$. The net stabilization energy of cyclobutadiene is -2β *i.e.* cyclobutadiene is *destabilized* by 2β compared with two isolated double bonds and thus is very reactive and will react as a di-radical. It is unstable above 35 K and dimerizes by a Diels-Alder reaction. As expected cyclobutadiene is not aromatic and it does not have aromatic stability as it does not have $(4n+2)$ π -electrons as in Hückel's rule for monocyclic compounds.

To determine the eigenvectors for a cyclic molecule we need to solve the general Hückel matrix equation shown below for a generalized cyclic molecules.

$$\begin{pmatrix}
 x & 1 & 0 & \cdots & 0 & 0 & 1 \\
 1 & x & 1 & \cdots & 0 & 0 & 0 \\
 0 & 1 & x & \cdots & 0 & 0 & 0 \\
 0 & 0 & 0 & \cdots & 1 & 0 & 0 \\
 0 & 0 & 0 & \cdots & x & 1 & 0 \\
 0 & 0 & 0 & \cdots & 1 & x & 1 \\
 1 & 0 & 0 & \cdots & 0 & 1 & x
 \end{pmatrix}
 \begin{pmatrix}
 c_1 \\
 c_2 \\
 c_3 \\
 c_4 \\
 \cdots \\
 c_n
 \end{pmatrix}
 =
 \begin{pmatrix}
 0 \\
 0 \\
 0 \\
 0 \\
 \cdots \\
 0
 \end{pmatrix}$$

The general solution for the wavefunctions are complex (contain an imaginary part due to motion of the particle in either direction around the ring) but the real functions may be found from linear combinations the solutions in pairs. The two real solutions are given below,

$${}^{k+}\psi \propto \sum_s \cos\left(\frac{2\pi k s}{n}\right) \phi_s \quad {}^{k-}\psi \propto \sum_s \sin\left(\frac{2\pi k s}{n}\right) \phi_s$$

The coefficients will have to be normalized by dividing by the normalization constant N . For $k = 0$ are,

$$\begin{array}{l}
 {}^0\psi \propto \cos\frac{2\pi \times 0 \times 1}{4} \phi_1 + \cos\frac{2\pi \times 0 \times 2}{4} \phi_2 + \cos\frac{2\pi \times 0 \times 3}{4} \phi_3 + \cos\frac{2\pi \times 0 \times 4}{4} \phi_4 \\
 {}^0\psi \propto \quad \quad \quad +1 \phi_1 \quad \quad \quad +1 \phi_2 \quad \quad \quad +1 \phi_3 \quad \quad \quad +1 \phi_4
 \end{array}$$

The four coefficients are all in phase and form a delocalized π -bond around all four carbon atoms. This is the lowest energy Hückel MO conventionally labelled ψ_1 and the normalization constant is $N^2 = 4$ so $N = 2$.

$$\psi_1 = \frac{\phi_1}{2} + \frac{\phi_2}{2} + \frac{\phi_3}{2} + \frac{\phi_4}{2} \quad E_1 = \alpha + 2\beta$$

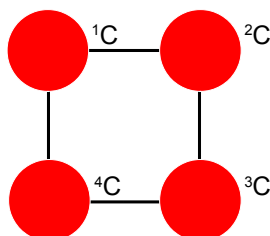

Figure 6.19: ψ_1 of cyclobutadiene looking down onto the $2p$ AOs.

The eigenvectors for $k = +1$ and $k = -1$ are,

$${}^{+1}\psi \propto \cos\left(\frac{2\pi \times 1 \times 1}{4}\right)\phi_1 + \cos\left(\frac{2\pi \times 1 \times 2}{4}\right)\phi_2 + \cos\left(\frac{2\pi \times 1 \times 3}{4}\right)\phi_3 + \cos\left(\frac{2\pi \times 1 \times 4}{4}\right)\phi_4$$

$${}^{-1}\psi \propto \sin\left(\frac{2\pi \times 1 \times 1}{4}\right)\phi_1 + \sin\left(\frac{2\pi \times 1 \times 2}{4}\right)\phi_2 + \sin\left(\frac{2\pi \times 1 \times 3}{4}\right)\phi_3 + \sin\left(\frac{2\pi \times 1 \times 4}{4}\right)\phi_4$$

$${}^{+1}\psi \propto 0\phi_1 - 1\phi_2 + 0\phi_3 + 1\phi_4$$

$${}^{-1}\psi \propto +1\phi_1 + 0\phi_2 - 1\phi_3 + 0\phi_4$$

Thus for $k = \pm 1$ the two real wavefunctions correspond to the two degenerate nonbonding SOMO wavefunctions. For degenerate wavefunctions then any linear combination gives a valid wavefunction (Levine 2009, p. 643). The sum and the difference of ${}^{+1}\psi$ and ${}^{-1}\psi$ are $\psi_2 = {}^{+1}\psi + {}^{-1}\psi$ and $\psi_3 = {}^{+1}\psi - {}^{-1}\psi$. They given below after normalization by dividing by 2. These degenerate pair of wavefunctions each consists of two isolated double bonds,

$$\psi_2 = +\frac{\phi_1}{2} - \frac{\phi_2}{2} - \frac{\phi_3}{2} + \frac{\phi_4}{2} \quad E_2 = \alpha$$

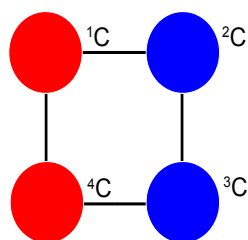

Figure 6.20: ψ_2 SOMO of cyclobutadiene looking down on the $2p$ AOs.

$$\psi_3 = -\frac{\phi_1}{2} - \frac{\phi_2}{2} + \frac{\phi_3}{2} + \frac{\phi_4}{2} \quad E_3 = \alpha$$

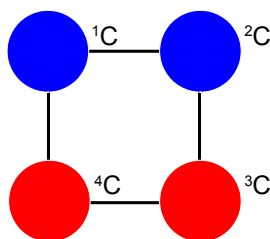

Figure 6.21: ψ_3 SOMO of cyclobutadiene looking down on the $2p$ AOs.

The eigenvector for $k = 2$ is

$$\begin{aligned} {}^2\psi &\propto \cos\left(\frac{2\pi \times 2 \times 1}{4}\right)\phi_1 + \cos\left(\frac{2\pi \times 2 \times 2}{4}\right)\phi_2 + \cos\left(\frac{2\pi \times 2 \times 3}{4}\right)\phi_3 + \cos\left(\frac{2\pi \times 2 \times 4}{4}\right)\phi_4 \\ {}^2\psi &\propto \quad -1\phi_1 \quad \quad \quad +1\phi_2 \quad \quad \quad -1\phi_3 \quad \quad \quad +1\phi_4 \end{aligned}$$

Thus for $k = 2$ the four coefficients are all out of phase with *both* of their neighbours forming a completely π -antibonding MO. This is the highest energy Hückel MO ψ_4 and the normalization constant is again $N = 2$.

$$\psi_4 = -\frac{\phi_1}{2} + \frac{\phi_2}{2} - \frac{\phi_3}{2} + \frac{\phi_4}{2} \quad E_4 = \alpha - 2\beta$$

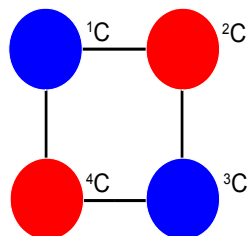

Figure 6.22: ψ_4 LUMO of cyclobutadiene looking down on the $2p$ AOs.

Although the Hückel method is now replaced by computer based semi-empirical, *ab initio*, or DFT methods the Hückel approximation is still great for allowing us to manually solve molecular orbitals and see what is behind these more sophisticated methods as well as giving us a good qualitative feel for the properties of the important class of both acyclic and cyclic conjugated molecules.

[Return to Question 4 \(see page 111\)](#)

7 Week 7: Chemistry and Vectors

We have been using vectors in Weeks 5 and 6 with matrices as the vertical column vectors (eigenvectors or wavefunctions). In our last two weeks we are going to use vectors more directly. In Fig. 7.1 the vector A is pointing in the positive directions along the x , y , z axes with components of a units, b units, c units, respectively. The vector is written as a column vector as below. The vector B is pointing in the negative x direction but the positive y and z directions which is shown in the signs of its column vector components. Some operations on vectors such as addition and subtraction may be treated purely as an exercise in trigonometry but we will use vector notation to link with the more complicated operations possible with vectors such as scalar and vector products. For clarity I will not explicitly show the unit vectors in the Cartesian coordinates.

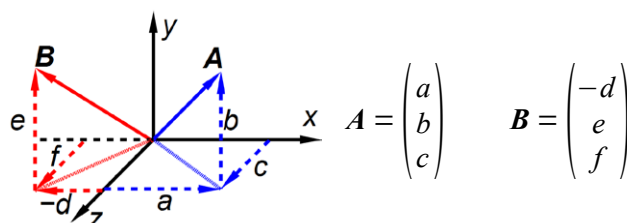

Figure 7.1: vector definition.



Sharp Minds - Bright Ideas!

Employees at FOSS Analytical A/S are living proof of the company value - First - using new inventions to make dedicated solutions for our customers. With sharp minds and cross functional teamwork, we constantly strive to develop new unique products - Would you like to join our team?

FOSS works diligently with innovation and development as basis for its growth. It is reflected in the fact that more than 200 of the 1200 employees in FOSS work with Research & Development in Scandinavia and USA. Engineers at FOSS work in production, development and marketing, within a wide range of different fields, i.e. Chemistry, Electronics, Mechanics, Software, Optics, Microbiology, Chemometrics.

We offer
A challenging job in an international and innovative company that is leading in its field. You will get the opportunity to work with the most advanced technology together with highly skilled colleagues.

Read more about FOSS at www.foss.dk - or go directly to our student site www.foss.dk/sharpminds where you can learn more about your possibilities of working together with us on projects, your thesis etc.

The Family owned FOSS group is the world leader as supplier of dedicated, high-tech analytical solutions which measure and control the quality and production of agricultural, food, pharmaceutical and chemical products. Main activities are initiated from Denmark, Sweden and USA with headquarters domiciled in Hillerød, DK. The products are marketed globally by 23 sales companies and an extensive net of distributors. In line with the corevalue to be 'First', the company intends to expand its market position.



Dedicated Analytical Solutions

FOSS
 Slangerupgade 69
 3400 Hillerød
 Tel. +45 70103370
www.foss.dk

7.1 Week 7 Tutorial Questions

7.1.1 Questions 1: Time of Flight Mass Spectrometer

A time-of-flight (TOF) mass spectrometer is sketched below.

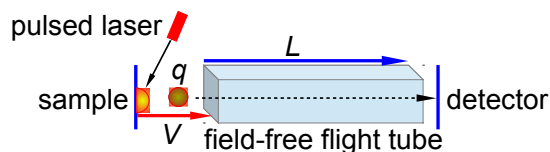

Figure 7.2: schematic time of flight mass spectrometer.

The TOF MS is all under a vacuum. A pulsed laser fires a pulse of light onto a sample plate causing a pulse of ions of mass m and charge q to be ejected from the sample ($q = ze$ the number of charges z and e the elementary charge). The ions are accelerated by a voltage V applied between the sample plate and the flight tube. The flight tube is of length L (typically 1 metre) with no electric or magnetic fields in it. The pulse of ions leave the flight tube and strikes the detector. The electric field V gives the ions a kinetic energy E_k with a velocity v of the ions in the flight tube.

$$E_k = \frac{mv^2}{2} = qV \quad v = (2qV/m)^{1/2}$$

The ions travel the distance L to the detector in a time t and rearranging the equations we have

$$t = \frac{L}{v} \quad t^2 = \frac{m}{q} \left(\frac{L^2}{2V} \right) \quad \frac{m}{q} = \frac{2V}{L^2} t^2$$

As the voltage V and the flight tube length L are fixed, the value of m/q is directly related to the square of the time of flight. Firstly, rewrite these equations in vector notation. Secondly, if $L = 1$ m, and $V = 5$ kV, find the time of flight of a H^+ ion of mass 1.673×10^{-27} kg and charge 1.602×10^{-19} C down the flight tube (be careful with the units). The flight time in the short acceleration region may be safely ignored.

[Jump to Solution 1 \(see page 131\)](#)

7.1.2 Question 2: Dipole Moments of Molecules

As vectors have magnitude and direction, the first thing to decide is the direction of the dipole. The electric dipole moment (or just dipole moment) μ (mu) is modelled as two equal but opposite charges in a molecule Q and $-Q$ multiplied by a distance d separating the partial charges.

$$\mu = Qd$$

It is a vector that points *from the negative towards the positive end* of the molecule. This is the internationally agreed sign convention. Some chemists use a non-standard arrow pointing towards the negative end to signify the movement of electrons and a cross at the positive end of the molecule. It should be made clear which system is being used, we will be using the “official” convention. The SI unit of dipole moment is the coulomb metre, which is much too large for use with molecules, so dipole moments are measured in debye (symbol D) where $1 \text{ D} = 3.335641 \times 10^{-30} \text{ C m}$.

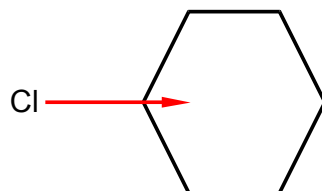

Figure 7.3: chlorobenzene dipole moment.

Chlorobenzene has a dipole moment of magnitude 1.5 D due to the polarized C-Cl bond. Calculate by vector addition the magnitudes and directions of the overall dipole moments for the isomers of dichlorobenzene *ortho*-dichlorobenzene (1,2-dichlorobenzene), *meta*-dichlorobenzene (1,3-dichlorobenzene) and *para*-dichlorobenzene (1,4-dichlorobenzene) assuming that the benzene ring is a perfect hexagon and the bond dipole $\mu_{\text{C-Cl}}$ remains constant at 1.5 D.

[Jump to Solution 2 \(see page 131\)](#)

7.1.3 Question 3: The Absorption of Light by Polar Molecules

It is possible to arrange molecules so that the bond dipoles all point in a particular direction. Fig.7.4 shows the alignment of carbonyl bonds in a sample. The magnitude of the carbonyl dipole moment is 2.5 D.

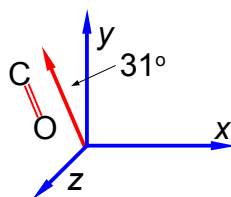

Figure 7.4: aligned carbonyl groups.

The spectroscopic absorbance (A) of any sample is proportional to the magnitude of the *component* of the dipole which is parallel to the direction of polarization of the radiation used. Resolve the carbonyl dipole vector and hence calculate the ratio of the absorbances of the sample when the radiation is vertically polarized (v) to when it is horizontally polarized (h).

[Jump to Solution 3 \(see page 133\)](#)

7.1.4 Question 4: Hydrogen Halide Dipole Moments

The magnitudes of the four hydrogen halide dipoles are given below.

	HF	HCl	HBr	HI
μ/D	1.91	1.08	0.80	0.42

Firstly, using *vector notation*, express the magnitudes of the HF, HBr and the HI dipoles as scalar multiples of the HCl dipole magnitude. Secondly, Fig. 7.5 shows phosgene, in what direction does the phosgene molecular dipole point and what is its magnitude assuming the bond angles are 120° apart?

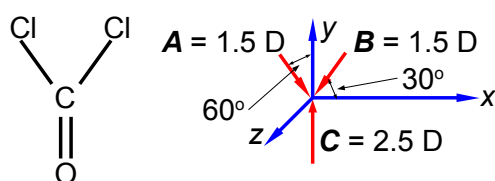

Figure 7.5: phosgene.

[Jump to Solution 4 \(see page 134\)](#)

“I studied English for 16 years but...
...I finally learned to speak it in just six lessons”
Jane, Chinese architect

ENGLISH OUT THERE

Click to hear me talking before and after my unique course download

7.2 Week 7 Tutorial Solutions

7.2.1 Solution 1: Time of Flight Mass Spectrometer

$$E_k = \frac{mv^2}{2} = qV \quad v = \sqrt{\frac{2qV}{m}}$$

$$t = \frac{L}{v} \quad t^2 = \frac{m}{q} \frac{L^2}{2V} \quad \frac{m}{q} = \frac{2V}{L^2} t^2$$

$$\frac{1.673 \times 10^{-27} \text{ kg}}{1.602 \times 10^{-19} \text{ C}} = \frac{2 \times 5 \times 10^3 \text{ V}}{1^2 \text{ m}^2} t^2$$

$$t^2 = \frac{1.673 \times 10^{-27} \text{ kg m}^2}{(1.602 \times 10^{-19} \text{ C})(1 \times 10^4 \text{ V})} = 1.044 \times 10^{-12} \text{ s}^2 \quad t = 1.022 \times 10^{-6} \text{ s}$$

Work = force × distance and so $V C = J = N m$ but also force = mass × acceleration = kg m s^{-2} and so $V C = J = \text{kg m}^2 \text{ s}^{-2}$. The proton has a flight time of about a microsecond.

[Return to Question 1 \(see page 128\)](#)

7.2.2 Solution 2: Dipole Moments of Molecules

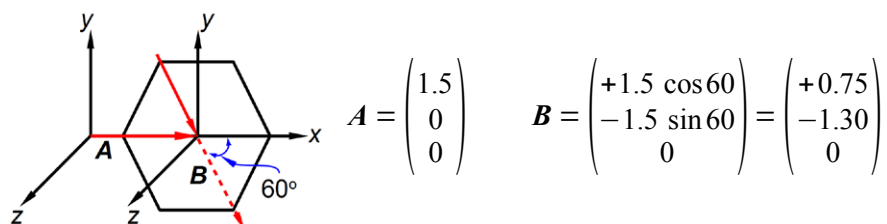

Figure 7.6: 1,2-dichlorobenzene C-Cl bond dipole vectors, units not shown.

The two bond dipole moment vectors **A** and **B** each have their own components which is most clearly shown by drawing parallel Cartesian axes for the “dotted” **B** vector as shown in Fig. 7.6. Adding the two vectors gives us the molecule’s overall dipole vector **C**.

$$C = \begin{pmatrix} 1.5 \\ 0 \\ 0 \end{pmatrix} + \begin{pmatrix} +0.75 \\ -1.30 \\ 0 \end{pmatrix} = \begin{pmatrix} +2.25 \\ -1.30 \\ 0 \end{pmatrix} \quad |C| = \sqrt{2.25^2 + (-1.30)^2 + 0^2} = 2.6 \text{ D}$$

The angle, θ , that **C** makes with the x -axis is found from $\tan \theta = C_y / C_x$ as below,

$$\theta = \tan^{-1} \frac{-1.30 \text{ D}}{2.25 \text{ D}} = -30^\circ$$

That is the molecule's dipole moment bisects the bond dipoles as in Fig. 7.7.

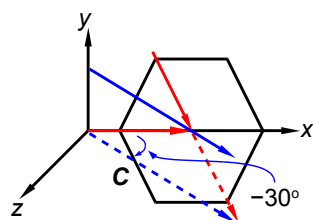

Figure 7.7: 1,2-dichlorobenzene dipole moment $C = 2.6$ D at 30° to both C-Cl dipoles.

The *meta*-dichlorobenzene vector diagram is shown in Fig. 7.8.

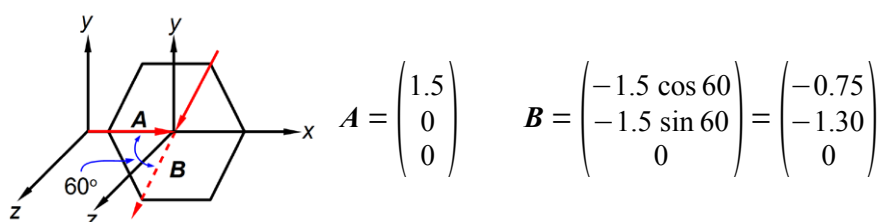

Figure 7.8: 1,3-dichlorobenzene C-Cl bond dipole vectors, units not shown.

Adding the two vectors A and B gives us the molecule's overall dipole vector C .

$$\mathbf{C} = \begin{pmatrix} 1.5 \\ 0 \\ 0 \end{pmatrix} + \begin{pmatrix} -0.75 \\ -1.30 \\ 0 \end{pmatrix} = \begin{pmatrix} +0.75 \\ -1.30 \\ 0 \end{pmatrix} \quad |\mathbf{C}| = \sqrt{0.75^2 + (-1.30)^2 + 0^2} = 1.5 \text{ D}$$

The angle, θ , that C makes with the x -axis is found from $\tan \theta = C_y/C_x$

$$\theta = \tan^{-1} \frac{-1.30 \text{ D}}{0.75 \text{ D}} = -60^\circ$$

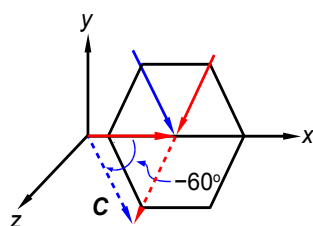

Figure 7.9: 1,3-dichlorobenzene dipole moment $C = 1.5$ D at 60° to both C-Cl dipoles.

For *para*-dichlorobenzene the two bond dipole moment vectors are at 180° to one another and cancel out, adding the two vectors A and B gives us the molecule's overall dipole vector $C = 0$ D.

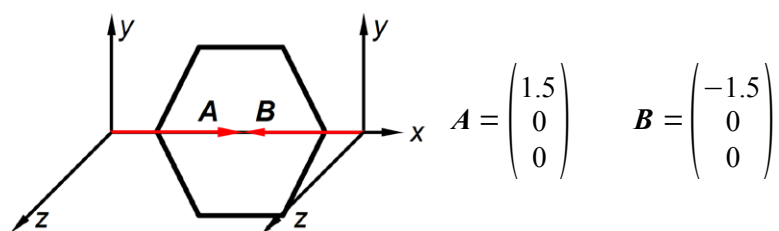

Figure 7.10: 1,4-dichlorobenzene C-Cl bond dipole vectors, units not shown.

$$C = \begin{pmatrix} 1.5 \\ 0 \\ 0 \end{pmatrix} + \begin{pmatrix} -1.5 \\ 0 \\ 0 \end{pmatrix} = \begin{pmatrix} 0 \\ 0 \\ 0 \end{pmatrix} \quad |C| = \sqrt{0^2 + 0^2 + 0^2} = 0 \text{ D}$$

The dipole moment of 1,4-dichlorobenzene is 0 D, *i.e.* it is a non-polar molecule.

[Return to Question 2 \(see page 128\)](#)

7.2.3 Solution 3: The Absorption of Light by Polar Molecules

In this question we are given the resultant molecular dipole moment vector and we have to resolve it into its horizontal (\mathbf{h}) and vertical (\mathbf{v}) component dipoles.

The Wake
the only emission we want to leave behind

Low-speed Engines Medium-speed Engines Turbochargers Propellers Propulsion Packages PrimeServ

The design of eco-friendly marine power and propulsion solutions is crucial for MAN Diesel & Turbo. Power competencies are offered with the world's largest engine programme – having outputs spanning from 450 to 87,220 kW per engine. Get up front! Find out more at www.mandieselturbo.com

Engineering the Future – since 1758.
MAN Diesel & Turbo



Click on the ad to read more

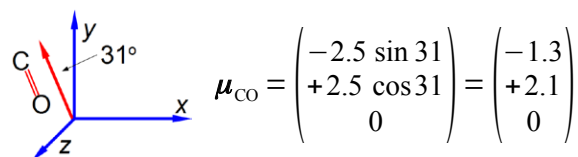

Figure 7.11: the components of the aligned carbonyl groups.

The ratio of the spectroscopic absorbances for vertical polarisation (v) to horizontal polarisation (h) is independent of the signs of the components *i.e.* you can't have a negative absorbance.

$$\frac{v}{h} = \frac{|2.1\text{D}|}{|1.3\text{D}|} = 1.6$$

[Return to Question 3 \(see page 129\)](#)

7.2.4 Solution 4: Hydrogen Halide Dipole Moments

The ratios of the magnitudes are and thus the scalar multiples of the HCl dipole magnitude are

$$\frac{|\mu_{\text{HF}}|}{|\mu_{\text{HCl}}|} = \frac{1.91\text{ D}}{1.08\text{ D}} = 1.77 \quad \frac{|\mu_{\text{HBr}}|}{|\mu_{\text{HCl}}|} = \frac{0.80\text{ D}}{1.08\text{ D}} = 0.74 \quad \frac{|\mu_{\text{HI}}|}{|\mu_{\text{HCl}}|} = \frac{0.42\text{ D}}{1.08\text{ D}} = 0.39$$

$$|\mu_{\text{HF}}| = 1.77 |\mu_{\text{HCl}}| \quad |\mu_{\text{HBr}}| = 0.74 |\mu_{\text{HCl}}| \quad |\mu_{\text{HI}}| = 0.39 |\mu_{\text{HCl}}|$$

The three bond dipole vectors of phosgene are shown below,

Vector addition gives the overall dipole moment, D , of the molecule.

$$A = \begin{pmatrix} +1.3 \\ -0.75 \\ 0 \end{pmatrix} \quad B = \begin{pmatrix} -1.3 \\ -0.75 \\ 0 \end{pmatrix} \quad C = \begin{pmatrix} 0 \\ +2.5 \\ 0 \end{pmatrix} \quad \text{thus } D = \begin{pmatrix} 0 \\ +1.0 \\ 0 \end{pmatrix}$$

The horizontal components for each of the two C-Cl bond dipoles cancel one another out. The molecular dipole of phosgene is 1.0 D along the y -axis in the positive direction.

[Return to Question 4 \(see page 130\)](#)

8 Week 8: Chemistry and Vectors

8.1 Week 8 Tutorial Questions

8.1.1 Question 1: Methane Structure

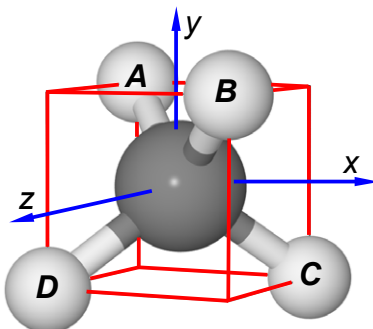



Figure 8.1: methane in a cubic box of length 2 unit vectors.

 **gaiteye**[®]
Challenge the way we run

**EXPERIENCE THE POWER OF
FULL ENGAGEMENT...**

.....

**RUN FASTER.
RUN LONGER..
RUN EASIER...**

**READ MORE & PRE-ORDER TODAY
WWW.GAITEYE.COM**

Methane is tetrahedral, that is it fits inside a cube with the carbon atom at the intersection of any two diagonals, which is at the origin (0, 0, 0), Fig. 8.1. Two hydrogen atoms sit on the top face at the ends of a “horizontal” diagonal and the other two hydrogen atoms are on the bottom face at the ends of the other “horizontal” diagonal. Firstly, if the cube has sides of length 2 unit vectors calculate the bond vectors from the C-atom to each H-atom **A**, **B**, **C** and **D**. Secondly, choose any two bonds and use the vector product (*scalar product*) to calculate the angle between them. Thirdly, choose any two bonds and use the vector product (*cross product*) to calculate the area of the triangle formed by these two bonds.

[Jump to Solution 1 \(see page 138\)](#)

8.1.2 Question 2: Magnetic Sector Mass Spectrometer

A cation of charge q travelling with a velocity \mathbf{v} enters a magnetic field \mathbf{B} at right angles ($\theta = 90^\circ$) to the field and experiences a magnetic force \mathbf{F}_M which is the vector product, below. Draw a diagram to describe the direction of the force felt by a cation. What would be the direction of the force vector for an anion?

$$q(\mathbf{v} \times \mathbf{B}) = \mathbf{F}_M$$

In a practical mass spectrometer the magnetic sector is not straight but the north and south poles are both curved round into an arc of a circle (typically 90°). The ion follows a circular path of radius r whilst inside this field. The centripetal force \mathbf{F}_C required to balance this magnetic force is $\mathbf{F}_C = m\mathbf{v}^2/r$.

$$\frac{m\mathbf{v}^2}{r} = q(\mathbf{v} \times \mathbf{B})$$

Draw a vector diagram of the various vectors and forces experienced by the positive ions during its time inside the circular magnetic field.

[Jump to Solution 2 \(see page 140\)](#)

8.1.3 Question 3: Electron Spin and Orbital Angular Momentum

From our atomic structure lectures we know an electron can only have an intrinsic spin vector of $\mathbf{s} = \frac{1}{2}$. From quantum mechanics the magnitude of the spin vector is $|\mathbf{s}|$ is,

$$|\mathbf{s}| = \sqrt{s(s+1)} \hbar = \sqrt{3/4} \hbar$$

where \hbar (h bar) is Planck's constant divided by 2π . Quantum mechanics also restricts the value of the *component* of \mathbf{s} along the z -axis of the electron to m_z to $\pm\frac{1}{2}\hbar$ (spin up \uparrow and spin down \downarrow). What about the other two Cartesian components of the spin vector (m_x and m_y), can we say anything about them? Due to Heisenberg's Uncertainty Principle if we know m_z exactly then we can know nothing about m_x and m_y hence our spin vector points somewhere on a *cone of uncertainty* as in Fig. 8.2. Calculate the half-angle of the cone of uncertainty θ of the electron spin angular momentum vectors.

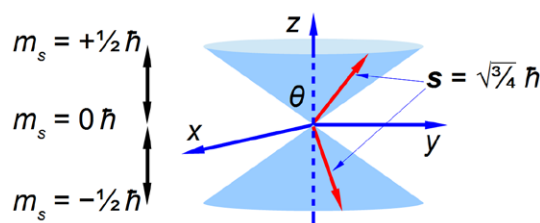

Figure 8.2: the two allowed orientations of the $s = \frac{1}{2}$ electron spin angular momentum vector.

The $2p$ electrons have an *orbital* angular momentum $l = 1\hbar$. From quantum mechanics the magnitude of the orbital angular momentum vector is $|l|$.

$$|l| = \sqrt{l(l+1)} \hbar = \sqrt{2} \hbar$$

Quantum mechanics also restricts the value of the component along the z -axis to one of three possible values m_z equal to $+1\hbar$, $0\hbar$, or $-1\hbar$. Again because we know the value of the component along the z -axis exactly, we know nothing about the values along the x -axis and y -axis. The orbital angular momentum vector points somewhere on one of three “cones of uncertainty” as in Fig. 8.3. Calculate the half-angles of the cones of uncertainty θ of the electron orbital angular momentum vectors.

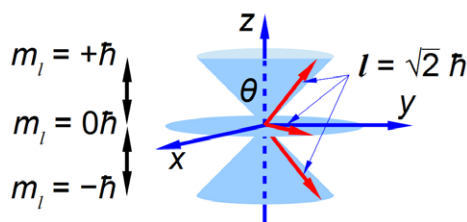

Figure 8.3: the three allowed orientations of the $l = 1$ electron orbital angular momentum vector.

[Jump to Solution 3 \(see page 140\)](#)

8.2 Week 8 Tutorial Solutions

8.2.1 Solution 1: Methane Structure

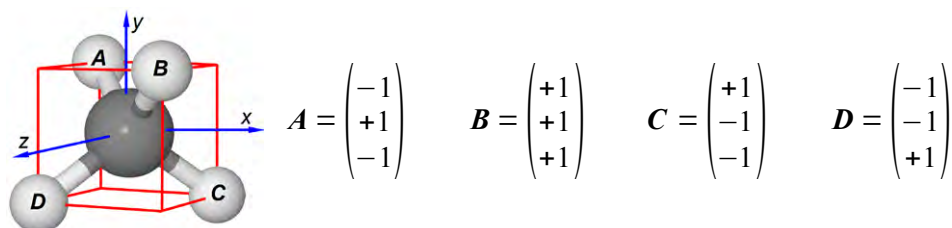

Figure 8.4: methane C-H bond vectors.

From the C-atom (at the origin) to the H-atoms the four bond vectors are given in Fig. 8.4. Secondly, if A and B are two vectors with components A_x, A_y, A_z and B_x, B_y, B_z with an angle θ between them, then the scalar product (or dot product) may be written in either of two ways.

$$A \cdot B = A_x B_x + A_y B_y + A_z B_z = |A||B|\cos\theta \quad \text{The scalar product or dot product}$$

The scalar product as its name implies is a scalar quantity and is used most often in Chemistry to find the angle between two vectors and also for the potential energy of a magnetic dipole in a magnetic field (e.g. electron spin ESR and nuclear spin NMR). Choosing A and B as the two bond vectors (it doesn't matter which pair you choose) we have for the left hand side of the scalar product.



Technical training on *WHAT* you need, *WHEN* you need it

At IDC Technologies we can tailor our technical and engineering training workshops to suit your needs. We have extensive experience in training technical and engineering staff and have trained people in organisations such as General Motors, Shell, Siemens, BHP and Honeywell to name a few.

Our onsite training is cost effective, convenient and completely customisable to the technical and engineering areas you want covered. Our workshops are all comprehensive hands-on learning experiences with ample time given to practical sessions and demonstrations. We communicate well to ensure that workshop content and timing match the knowledge, skills, and abilities of the participants.

We run onsite training all year round and hold the workshops on your premises or a venue of your choice for your convenience.

For a no obligation proposal, contact us today at training@idc-online.com or visit our website for more information: www.idc-online.com/onsite/

**OIL & GAS
ENGINEERING**

ELECTRONICS

**AUTOMATION &
PROCESS CONTROL**

**MECHANICAL
ENGINEERING**

**INDUSTRIAL
DATA COMMS**

**ELECTRICAL
POWER**



Phone: +61 8 9321 1702
Email: training@idc-online.com
Website: www.idc-online.com

$$\mathbf{A} \cdot \mathbf{B} = \begin{pmatrix} -1 \\ +1 \\ -1 \end{pmatrix} \cdot \begin{pmatrix} +1 \\ +1 \\ +1 \end{pmatrix} = (-1 \times 1) + (1 \times 1) + (-1 \times 1) = -1$$

For the right hand side of the scalar product we have

$$|\mathbf{A}| = \sqrt{(-1)^2 + 1^2 + (-1)^2} = \sqrt{3} \quad |\mathbf{B}| = \sqrt{1^2 + 1^2 + 1^2} = \sqrt{3} \quad |\mathbf{A}||\mathbf{B}| \cos \theta = 3 \cos \theta$$

equating the two sides of the scalar product gives us the angle between the two C-H bonds in methane which is the tetrahedral angle.

$$-1 = 3 \cos \theta \quad \theta = 109.5^\circ$$

Thirdly, we are asked for the area of the triangle formed by the C-atom and any two H-atoms, this is obtained by using the vector product or the cross product. An *area* can be represented by a vector at right angles to the surface of the parallelogram formed from the two vectors \mathbf{A} and \mathbf{B} as in Fig. 8.5.

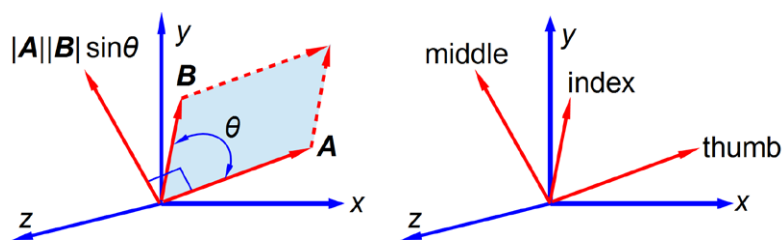

Figure 8.5: vector product or cross product and the right hand rule.

$$\mathbf{A} \times \mathbf{B} = |\mathbf{A}| |\mathbf{B}| \sin \theta \quad \text{The vector product or cross product}$$

The direction of the vector $\mathbf{A} \times \mathbf{B}$ is found from the right hand rule. Arrange your thumb, index and middle fingers of your right hand at right angles to one another, align the thumb with the first vector \mathbf{A} , then align the index finger with the second vector \mathbf{B} , then the middle finger points in the direction of the third vector, the cross product $|\mathbf{A}||\mathbf{B}|\sin \theta$, *i.e.* you count 1, 2, 3 from your thumb for the three vectors \mathbf{A} , \mathbf{B} , and their vector product.

$$\mathbf{A} \times \mathbf{B} = \sqrt{3} \times \sqrt{3} \times \sin 109.5^\circ = 2.828 \text{ units}^2$$

This is the area of the *parallelogram* but we only want half of this for the triangle formed by vectors \mathbf{A} and \mathbf{B} .

$$\frac{\mathbf{A} \times \mathbf{B}}{2} = 1.414 \text{ units}^2$$

[Return to Question 1 \(see page 135\)](#)

8.2.2 Solution 2: Magnetic Sector Mass Spectrometer

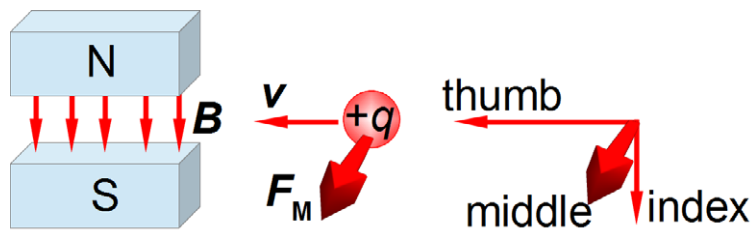

Figure 8.6: direction of the magnetic force on a moving positive ion.

$$q(\mathbf{v} \times \mathbf{B}) = \mathbf{F}_M$$

For a negative ion the force vector would point in the opposite direction.

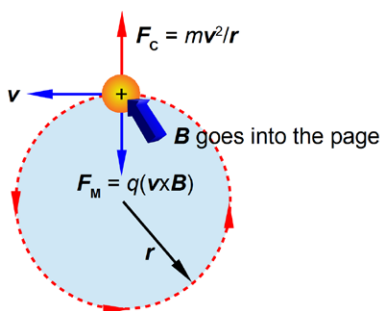

Figure 8.7: vectors and forces on a cation in a circular magnetic field.

[Return to Question 2 \(see page 136\)](#)

8.2.3 Solution 3: Electron Spin and Orbital Angular Momentum

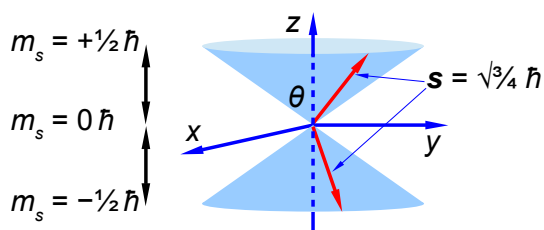

Figure 8.8: the two allowed orientations of the $s = \frac{1}{2}$ electron spin angular momentum vector.

$$m_s = +\frac{1}{2} \theta = \cos^{-1}\left(\frac{1/2 \hbar}{\sqrt{3}/4 \hbar}\right) = 54.7^\circ \quad m_s = -\frac{1}{2} \theta = \cos^{-1}\left(\frac{-1/2 \hbar}{\sqrt{3}/4 \hbar}\right) = 125.3^\circ$$

The angles of the two half cones for the electron spin are measured from the *positive* z direction, so the $m_s = -\frac{1}{2}$ cone half-angle is $\theta = 180^\circ - 125.3^\circ = 54.7^\circ$ from the *negative* z -axis. The electron orbital angular momentum vector point in one of three orientations for the p atomic orbitals.

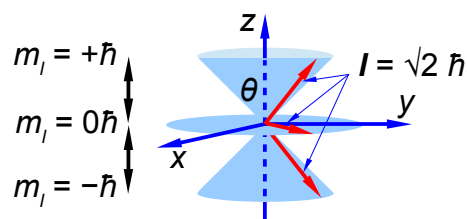

Figure 8.9: the three allowed orientations of the $l = 1$ electron orbital angular momentum vector.

$$m_l = +1 \quad \theta = \cos^{-1}\left(\frac{1 \hbar}{\sqrt{2} \hbar}\right) = 45^\circ \quad m_l = 0 \quad \theta = \cos^{-1}\left(\frac{0 \hbar}{\sqrt{2} \hbar}\right) = 90^\circ \quad m_l = -1 \quad \theta = \cos^{-1}\left(\frac{-1 \hbar}{\sqrt{2} \hbar}\right) = 135^\circ$$

The $m_l = -1$ cone half-angle is $\theta = 180^\circ - 135^\circ = 45^\circ$ from the *negative* z -axis.

[Return to Question 3 \(see page 136\)](#)

We have now finished our one year course of workbooks of Maths for Chemistry based students but keep using the three workbooks for revision and reference. Good luck with your degree.

I joined MITAS because
I wanted **real responsibility**

The Graduate Programme
for Engineers and Geoscientists
www.discovermitas.com



Real work
International opportunities
Three work placements



Month 16
I was a construction
supervisor in
the North Sea
advising and
helping foremen
solve problems



9 References

Atkins, P. & de Paula J. 2009, *Atkins' Physical Chemistry*, 9th edn. Oxford University Press, Oxford.

Blackman, A. Bottle, S. Schmid, S. Mocerino, M. & Wille, U. 2012, *Chemistry*, 2nd edn. John Wiley, Australia.

Blanco, M. Ituriaga, H. Maspoch, S. & Tarin, P 1989, "A Simple Method for Spectrophotometric Determination of Two-Components with Overlapped Spectra", *J. Chem. Educ.* vol. 66, no. 2, pp. 178-179.

Harris, D.C. 2007, *Quantitative Chemical Analysis*, 7th edn. Freeman and Co., New York.

Levine, I.N. 2009, *Physical Chemistry*, 6th edn, McGraw-Hill, New York.

LibreOffice Calc, <http://www.documentfoundation.org/>

Microsoft Excel, <http://office.microsoft.com/>.

OpenOffice.org Calc, <http://www.openoffice.org/>.

Parker, J.E. 2011, *Introductory Maths for Chemists: Chemistry Maths 1*, BookBoon.com, Copenhagen.

Parker, J.E. 2012, *Intermediate Maths for Chemists: Chemistry Maths 2*, BookBoon.com, Copenhagen.

Stroud, K.A. & Booth, D.J. 2007, *Engineering Mathematics*, 6th edn. Palgrave MacMillan, Basingstoke.

10 List of Formulae

Advanced Maths for Chemists the following are *some* of the formulae encountered in this book.

$$SSR = \sum_{i=1}^n (y_i - m x_i - c)^2$$

The sum of square of the residuals (SSR) for a straight line graph,

Electrochemistry and thermodynamics,

$$E = -\frac{\Delta H}{nF} + \frac{T\Delta S}{nF}$$

Heat capacity of a solid using the Shomate equation,

$$C_p = A + Bt + Ct^2 + Dt^3 + \frac{E}{t^2}$$

Michaelis-Menten equation,

$$v = \frac{V_{\max}[S]}{K_M + [S]}$$

Complex numbers,

$$i = (-1)^{1/2}$$

Euler's formula,

$$\exp(i\theta) = \cos\theta + i\sin\theta$$

$$\begin{pmatrix} x' \\ y' \\ z' \end{pmatrix} = \begin{pmatrix} 1 & 0 & 0 \\ 0 & 1 & 0 \\ 0 & 0 & -1 \end{pmatrix} \begin{pmatrix} x \\ y \\ z \end{pmatrix}$$

Molecular symmetry operations, reflection in the xy -plane,

$$\begin{pmatrix} \alpha - E & \beta \\ \beta & \alpha - E \end{pmatrix} \begin{pmatrix} c_1 \\ c_2 \end{pmatrix} = \begin{pmatrix} 0 \\ 0 \end{pmatrix} \quad \text{The Hückel Matrix}$$

$$\begin{vmatrix} \alpha - E & \beta \\ \beta & \alpha - E \end{vmatrix} = 0 \quad \text{The Hückel Secular Determinant}$$

$$\mathbf{A} \cdot \mathbf{B} = A_x B_x + A_y B_y + A_z B_z = |\mathbf{A}| |\mathbf{B}| \cos \theta \quad \text{The scalar product or dot product}$$

$$\mathbf{A} \times \mathbf{B} = |\mathbf{A}| |\mathbf{B}| \sin \theta \quad \text{The vector product or cross product}$$



www.job.oticon.dk

oticon
PEOPLE FIRST

