

# Designing of aseptic area

**GALGOTIAS**  
**UNIVERSITY**

## Disclaimer

All the content material provided here is only for teaching purpose.

The logo of Galgotias University is a circular emblem with a stylized 'G' shape inside. The 'G' is formed by three curved, overlapping bands in shades of orange, yellow, and blue. The background of the circle is a gradient of light blue and white.

GALGOTIAS  
UNIVERSITY

# Introduction

- Production of sterile products should be carried out in a clean environment with a **limit for the environmental quality of microbial and dust particle contamination.**
- This limit for contamination is **necessary to reduce the product contamination.**
- The production area is normally divided into
  - i)The clean-up area,**
  - ii) The compounding area,**
  - iii) The aseptic area,**
  - iv)The quarantine area and v)The packaging/labelling area.**

# Flow diagram of aseptic area

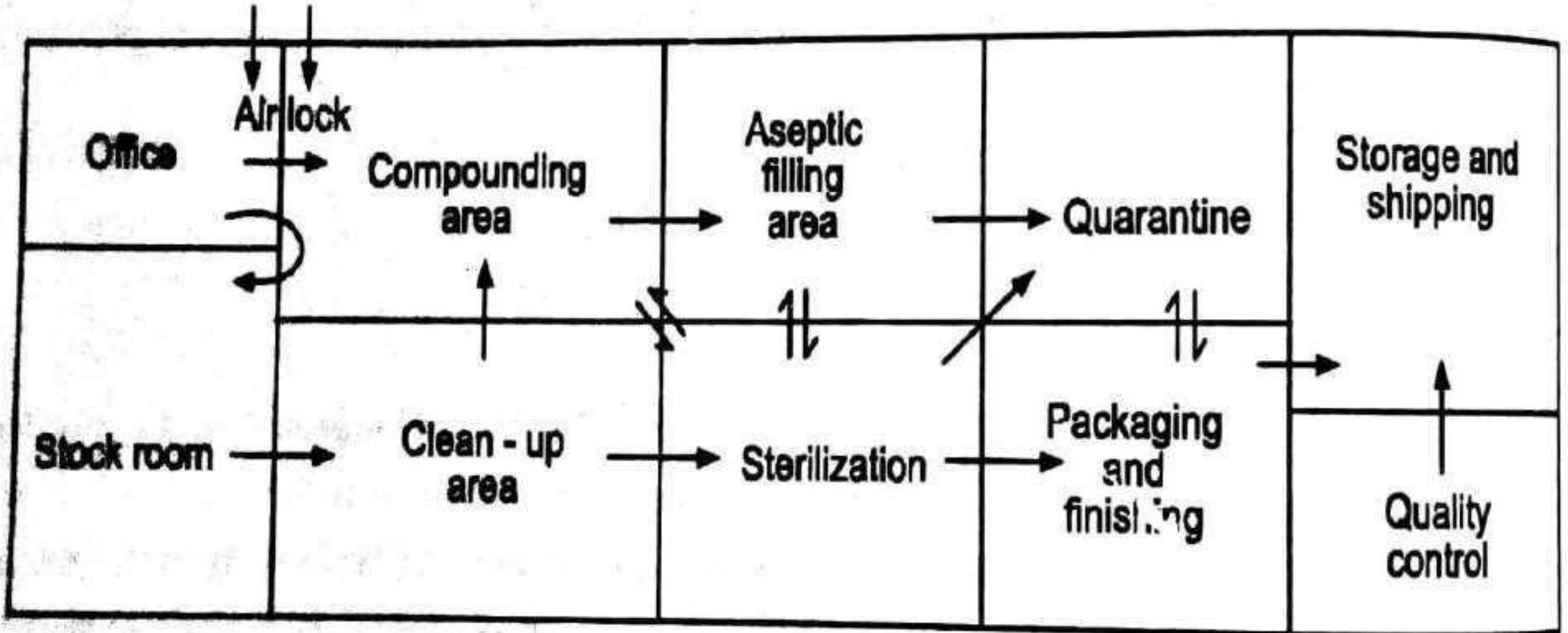

Fig. 18.1 : Flow diagram of aseptic area

# Clean-up section

- The cleaning area has walls and ceilings made up of film coating materials.
- Air inside the clean area should be free from dust and microorganisms.
- This is ensured through high efficiency (95%) filters.
- Air existing in the clean area should be frequently replace (10-15 air changes per hour).

# Compounding section

- This area contains stainless steel cabinets and counters and is involved in the actual compounding.
- Unlike aseptic area, maintenance of sterile conditions is not essential, but necessary measures should be adopted to control the dust generated from raw material during weighing and compounding.

# Aseptic area

- In this area, strict control measures should be adopted to avoid contamination of the preparations.
- The stainless steel counters and cabinets should be such that they should not allow dirt particles to accumulate.
- Mixing and storage of the compounded preparations should be done outside the aseptic area.
- The compounded preparations are then transferred to the aseptic area through pipelines where the filling operation is carried out.

# Quarantine section

- This area consists of a store where the in process batches as well as approved batches are stored separately.
- This area has limited access and is under the control of a responsible person.
- **Without the consent of the in charge**, other personnel cannot enter into this particular area.



# Packing and labelling section

- In this area, **the batches are packed and labelled.**
- Packing is carried out by **packaging machines**, while labels are **obtained by over printing devices.**
- At a time, only **one product labels are printed.**
- Parenteral packing plays a vital role in the production of sterile preparations.
- **Packing should be carried out in such a manner that the sterility of the product is maintained.**

# Floors, walls and ceilings

- All clean surfaces including the floor, walls and ceilings **must be smooth, easy to clean, disinfected and be constructed to minimize microbial and particulate contamination.**
- **Flexing and non-flexing** types of materials are used for construction of floor.
- **Flexing floor materials** are made up of synthetic elastomers of which most commonly used are polyvinylchloride (PVC). **PVC flooring is easily repaired, cleaned, relatively cheap and simple.**
- **Non-flexing floors** are made of hard inorganic filler substances in a matrix material.

- **Walls must be made up of non-inflammable or fire resistant material e.g:** Stainless steel, glass, enamelled steel, etc.
- Generally plaster walls are easily damaged by the impact.
- For reduction of fungal growth , **1% of 8- hydroxyquinolone, pentachlorophenol, etc may be added to the paint.**
- **Epoxy resin paints and polyurethane paints** are also used to avoid cracking and peeling.
- The ceilings are sealed to prevent the entry of microbial contaminants.
- Internal fittings such as a cupboards, drawers, shelves, and equipments must be kept to a minimum.

# Doors, windows and services

- Doors and windows should fit flush with the walls. Windows if required, are solely to provide illumination and are not for ventilation.
- **Windows should be non-openable.**
- Doors should be well fitted by maintaining the positive pressure air flow and self closing. Doors must be limited in number.
- **All pipes passing through the walls of the room should be effectively sealed and should be flush fitting and easily cleaned.**
- **Gas cylinders should be excluded and all gases should be piped from outside the area.**
- **Sinks and drains must be excluded from the areas where aseptic procedures are performed in clean room areas.**

- **Light sources in clean rooms are fitted with the ceilings to reduce the** collection of the dust and to avoid the disturbance of the air flow pattern with in the room.
- **Non essential switches such as room lighting switches should be** installed outside the clean area.

# Personnel and protective clothing

- The main source of contamination of clean areas arises from **skin scales which are released by the operators.**
- Personnel selected to work on the preparation of the parenteral products must be **neat and reliable.**
- They should be in **good health and free from dermatological conditions that might increase the microbial load.**
- **Operator –borne contamination can be controlled by limiting the number of operators in clean area.**
- **All personnel should be trained for Good Manufacturing Practices(GMP) and aseptic techniques.**
- The operator should wear sterile protective clothing including **head wear, powder free rubber or plastic gloves, a non-fibre shedding facemask and footwear.**
- All protective clothing is designed to prevent the contamination from the body.
- All protective clothing must be sterilized by **moist heat sterilization or ethylene oxide sterilization.**
- **Fresh sterile clothing** should normally be provided each time the person enters the aseptic area.



# Cleaning and disinfection

- Cleaning and disinfection procedures are used for the removal of microbial and particulate contamination.
- Cleaning agents are the alkaline detergents, non-ionic and ionic surfactants.
- Different types of disinfectants should be employed in rotation to prevent the development of resistant strains of microorganisms.
- Different concentration of **quarternary ammonium**

**compounds, sodium hypochloride, ethanol and solutions of formaldehyde are used as disinfectants in cleaning area.**

- **Cetrimide or chlorhexidine in 70% alcohol are suitable for use as skin disinfectants.**



# Air Supply

- The air supplied to a clean room must be filtered through **High Efficiency Particulate Air (HEPA) filters**.
- The HEPA filter must be positioned at the inlet of the clean room and the pre-filter may be fitted upstream of the HEPA filter to prolong the life of final filter.
- HEPA filters are used in the construction of vertical and horizontal laminar air flow bench.
- The air velocity at all parts of the filter area has to be **about 0.54 m/sec or (90±20 feet/min)**.
- **Removes the Dioctylphthalate (DOP) particles of size-0.3µm**
- The air filtered from the laminar air flow is claimed to be **99.97% free from the** microbial contamination.
- These filters are supported to provide **class 100 air and they should be certified every 6 to 12 months**.
- Air quality is evaluated using **settle plates, microbial air sampler or by particle counters**.

# Laminar flow equipment

1. Vertical laminar air flow bench

**2. Horizontal laminar air flow bench**

GALGOTIAS  
UNIVERSITY

# Vertical laminar air flow bench

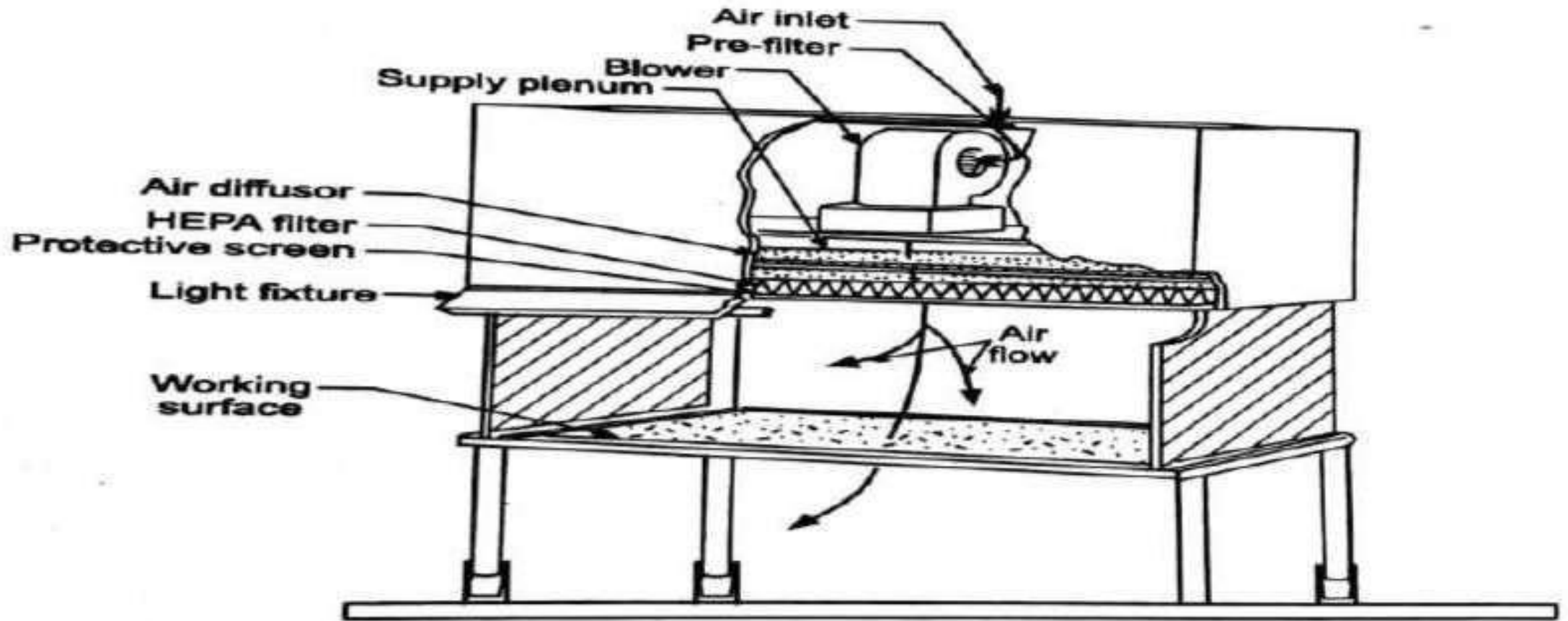

**Fig. 18.2 : Vertical laminar air flow bench**

# Horizontal laminar air flow bench

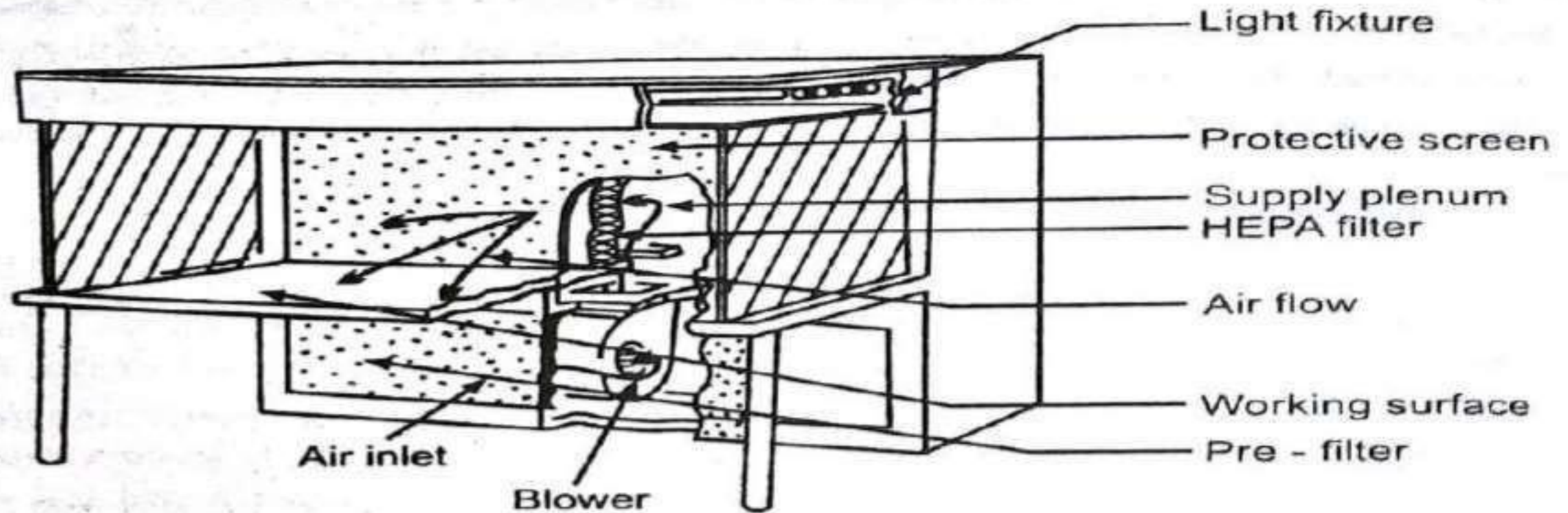

**Fig. 18.3 : Horizontal laminar air flow bench**

# Direction of air flow in horizontal laminar air flow

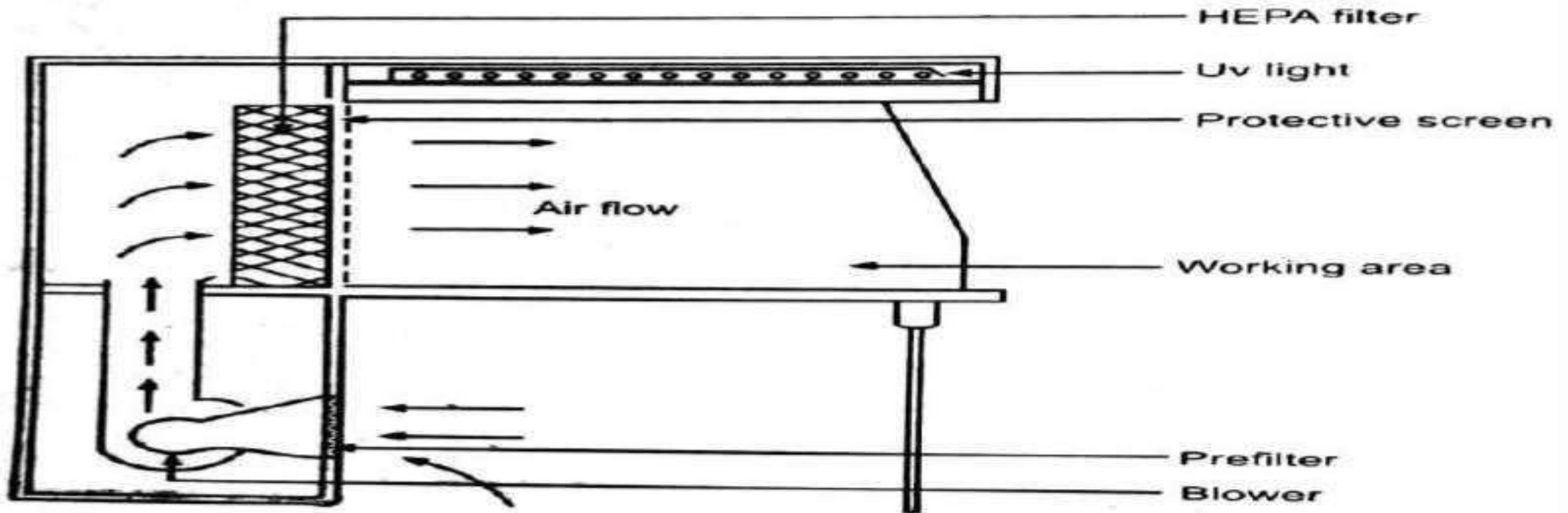
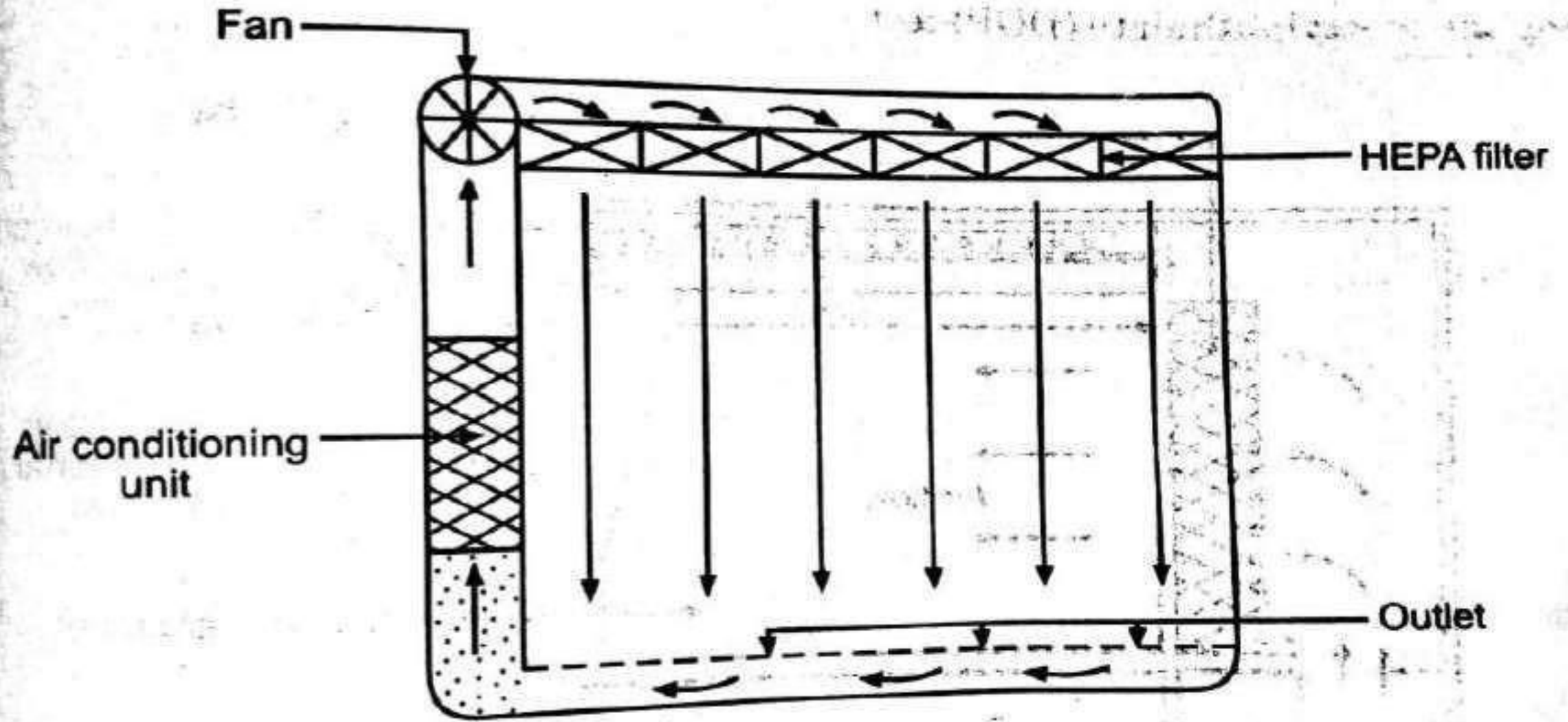

**Fig 18.4 : Direction of air flow in a horizontal laminar air flow**

# Air flow pattern

- The air flow pattern within the clean room must be carefully regulated
- To avoid generating particles from the clean room floor, walls and operators.
- The general airflow patterns in clean rooms are,
  - **1. Unidirectional airflow**
  - **2. Non-unidirectional airflow**
  - **3. Combined airflow**

# 1. Unidirectional airflow



## 2. Non-unidirectional airflow

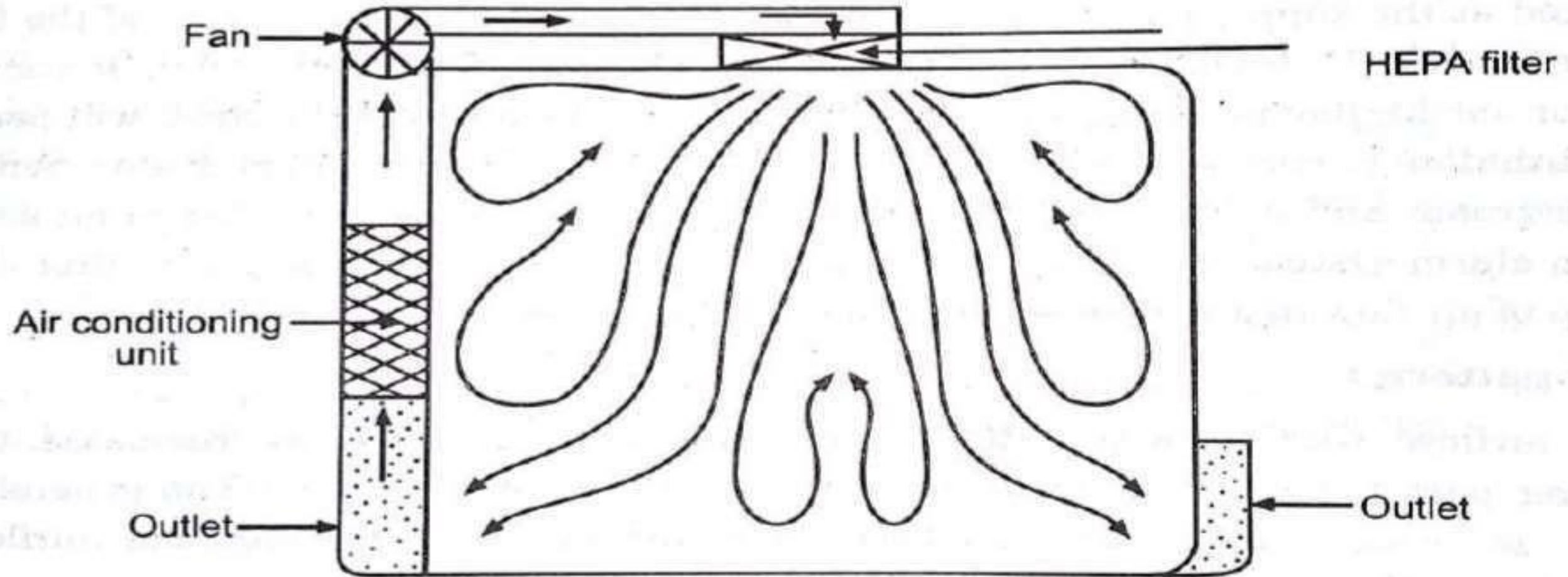



### 3. Combined airflow

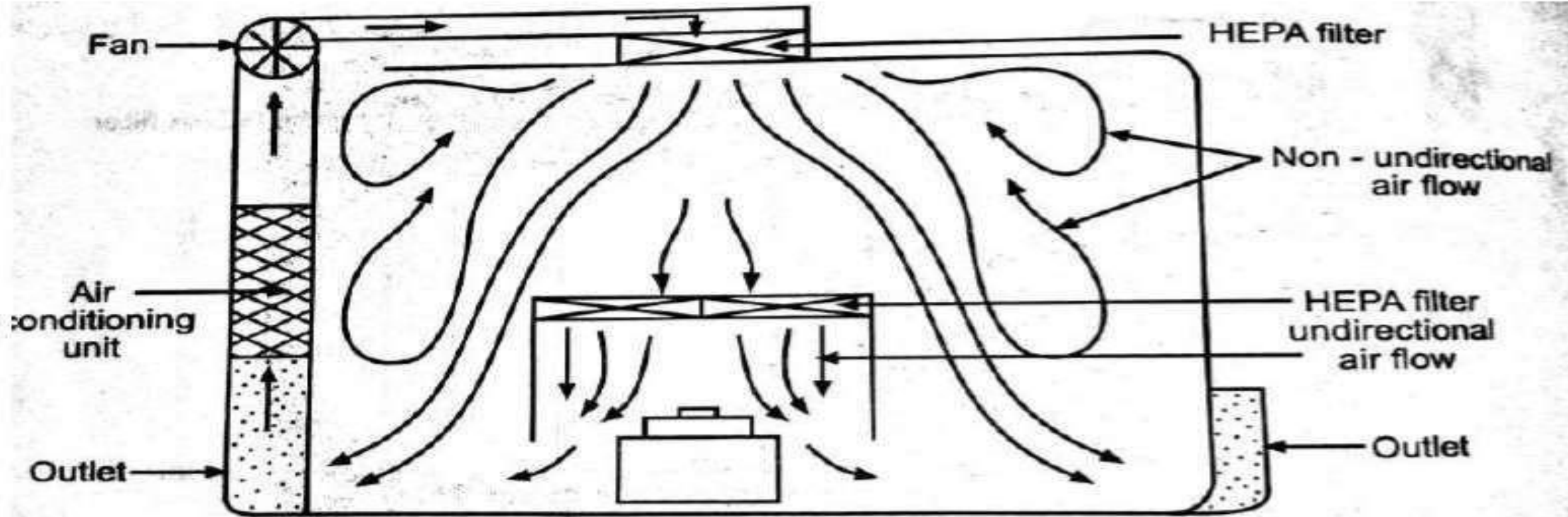

**Fig. 18.7 : Combined airflow pattern**

# Clean area Classification

	Maximum permitted number of particles per m <sup>3</sup> equal to or greater than the tabulated size			
	At rest		In operation	
Grade	0.5 µm	5.0 µm	0.5 µm	5.0 µm
A	3,520	20	3,520	20
B	3,520	29	352,000	2,900
C	352,000	2,900	3,520,000	29,000
D	3,520,000	29,000	Not defined	Not defined

# Sources of contamination in aseptic area and method to prevention

- Contamination, in broad sense, is the presence of minor unwanted particulate matter called contaminants in atmosphere, physical body, etc.
- Right from production to packaging almost every sector of pharmaceutical industry comes across contamination.
- The most common sources of contamination fall into the following three main categories:
  - **Atmospheric contamination**
  - **Fluid contamination**
  - **Transfer contaminants**

# 1. Atmospheric contamination

- Atmospheric conditions during manufacturing as well as during storage affects the quality of final preparation.
- Atmosphere in and around the industrial area contains potential contaminants like dust, silica, etc and gases like CO<sub>2</sub> , water vapour, etc.
- Besides the above mentioned contaminants, microorganisms like *P.aeruginosa*, *A.niger*, etc.
- These contaminants may get incorporated into the end product either during the process of manufacturing or during purification.

# Prevention:

- Prior to its entry into the working area, the air should be initially passed through a suitable pre- filter then treated with an electrostatic precipitator and finally through HEPA filters.
- Periodic removal of air-borne dust settled on walls, floors and ceilings is essential.

## 2.Fluid contamination

- Besides serving as the most common solvent in pharmaceutical industry, water also serves as the greatest solvent in pharmaceutical industry.
- Although, it is deprived of most of the contaminants yet it contains pyrogens and traces of sulphates, chlorides and carbonates of Ca, Mg and Na.
- Therefore, usage of water for washing the machineries and working areas may leave traces of these contaminants.

# Prevention:

- Almost all of the pharmaceutical operations should be carried out using purified water.
- depending upon deionization, distillation, ion exchange, reverse osmosis, filtration or other similar processes.
- For the preparation of parenterals, water for injection, sterile water for injection or bacteriostatic water for injection must be employed.

# 3. Transfer contaminants

- Transfer contaminants refer to the contaminants sourced from personnel and wheels of trolleys used for transport of goods.
- Personnel working in aseptic areas, if suffering from cold, allergies, dermatological conditions or any similar illness carry multiple microorganisms which upon expulsion into atmosphere via sneezing, coughing, talking etc., can lead to contamination.
- For example, atmospheric dust particles may get entangled with the fibres of the clothes which can get dislodged due to body movements and lead to contamination.



# Prevention:

- Personnel should be well trained and periodically evaluated in the principles of aseptic processing and techniques to be employed before participating in the preparation of sterile products.
- Apart from gown, the personnel area also required to put on face mask, head cap, gloves, foot covers and even goggle to ensure complete coverage of all skin areas.
- The entrance of most of the working areas is equipped with air blowers that aid in removing any loose dirt, lint from uniform of the operators.

- Those mechanical parts of the equipments that come in contact with the parenteral products should be demountable(removed from its setting) which enables their easy cleaning and sterilization.
- All the apparatus and their carriers being carried to the aseptic areas should be sterilized by suitable methods.

❖ Assignment on Air sampling Method

GALGOTIAS  
UNIVERSITY

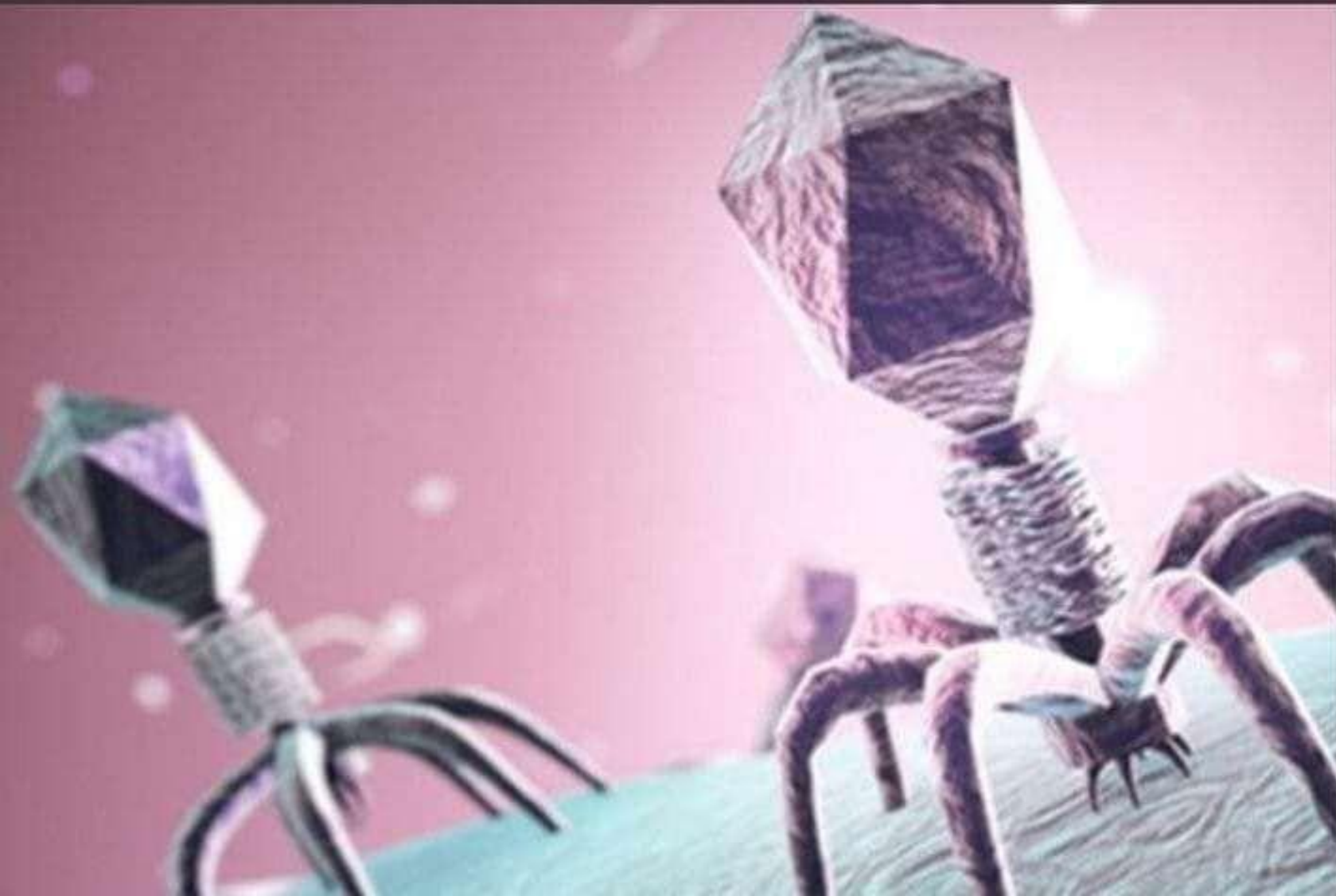

**WORLD  
PHAGE DAY**  
22 October

“TIME SPENT  
WITH A  
PHAGE  
IS NEVER  
WASTED.”

#WorldPhageDay

UNIVERSITY  
**THANK YOU**