

# **Smart Stick For Blind People.**

**1. ROHAN KUMAR GUPTA**

Admission No. : 19SCSE1010853

**2. DIVYA TOMAR**

Admission No. : 19SCSE1010367



**School of Computing Science and Engineering  
Greater Noida, Uttar Pradesh  
2021**

**Table of contents:****Pages:**

Abstract.....	03
Introduction.....	03
(i) Overall Description.....	03
(ii) Purpose.....	04
(iii) Motivations and Scope.....	04
Literature Survey.....	04
Proposed Model.....	05
Implementation (If any) .....	06
Conclusion and Future work.....	10
References.....	11

## **Abstract :**

Humans are not disabled. A person can never be broken. Our built environment, our technologies, is broken and disabled. We the people need not accept our limitations, but can transfer disability through technological Innovation. This Smart stick will have an Ultrasonic sensor to sense distance from any obstacle, LDR to sense lighting conditions and a RF remote using which the blind man could remotely locate his stick. The smart stick for blind people helps them to go anywhere or do their work easily and comfortably. In normal stick, no obstacles or problem occurred for blind people are not detected or searched. Normal stick is not comfortable for blind people to use it. Blind people don't know about the materials or obstacles in front them and they cannot calculate the distance and size of material or obstacles in front them. It is very difficult problem to move from here and there easily. Due to smart stick for blind people, it help to provide the detailed information about the materials or obstacles which helps them to move from here and there easily and comfortably. Smart stick detects objects with the help of sensors and measured the distance using ultrasonic sensors. It also can talk with the person who control it. It also give about the object which come near to the blind people who is using it while moving from here and there by using voice. It helps the people who need help from others to move anywhere.

## **1. Existing Problem :**

Nowadays, some of the people born with disability, in which blindness is most affective problem in the world. So, the list of blind people is increases day by day. And most of them are from poor family. Due to poor family, blind people are unable for treatment which may help to back their eye sight because of high money for eye transfer or transplant and lack of donner of eyes. They are unable to move or go anywhere easily. Most of the blind people died due to accident while crossing the road. Most of them are do suicide due to blindness.

## 2. Proposed Solution :

S. NO.	Items	Quantity	Rate	Amount
1.	Arduino Uno (Any version will work)	1.	389	389
2.	Ultrasonic Sensor HC-SR04	1	395	395
3.	LDR	1	195	195
4.	Buzzer	1	130	130
5.	LED 7805	1	25	25
6.	433MHz RF transmitter and receiver Resistors	1	329	329
7.	Push Button	1	25	25
8.	Perf Board	1	65	65
9.	Soldering Kit	1	250	250
10.	9v Battery	1	280	280
11.	Connecting Wires	25	2.69	67.25
<b>Grand Total</b>				2150.25

### Introduction:

A stick which help to the blind people to move anywhere easily is smart stick for blind people.

### (i) Overall description:

The smart stick is built on Arduino Pro Mini. This Arduino board is small enough to install on a regular stick and has buzzer, LDR sensor, Ultrasonic sensor and a water detector sensor interfaced to it. The stick also has an RF receiver which connects with an RF transmitter that acts as a remote for finding the stick on missing. The remote built on RF transmitter has a switch pressing which, the buzzer installed on the stick is triggered and by the sound of the buzzer a blind person can find the stick.

### **(ii) Purpose:**

To make the blind people life easier and as normal people. Most of the people are got suicide and accident. In the world, most of the blind people died due to accident while crossing the road. We want to make their life easier for them. The Arduino sketch manages to detect an obstacle, sense light, and water and invoke alarm on the press of the remote switch. The sketch is written on Arduino IDE and burnt to the controller board using the same. For demonstration, the circuit is built on a breadboard and it can be easily installed on any regular blind stick.

### **(iii) Motivations and scope:**

Through this blind stick a disabled person/blind person will able to compete with this normal world. Instead of needing a person to narrate him or help him to look for his way he is can be self realiant. Instead of sitting idol and waiting for something to help in his work he can alone perform his/her work.

This project had high scope ...as many more innovation can be done to this project to help a blind person to feel the way normal people do. Most of the smart stick are available in the market. It is available at higher cost and with less feature. Most of the people can't buy smart stick available in market because of the price. In the world, most of the people are poor and they don't have money to survive. So, we invent a device in low cost for the blind people. Everyone can buy either he/she

is poor or rich. So, It guides to blind people as their sensing power. It helps to make their life easier. It helps to convert disable to able.

### **3. Literature survey (Prior Art/Background):**

Smart Stick for the Blind People, a complete solution to reach the destination. This system uses IR sensor, Ultrasound sensor and water sensor to detect the obstacle. However, this system just gives an alert if any one of the sensor is triggered, it uses a buzzer to alert the blind person.

### **4. Proposed model:**

A stick which help to the blind people to move anywhere easily is smart stick for blind people. For the blindness problem, we are working in smart stick for blind people which help them to move or go anywhere easily. In the world, most of the blind people died due to accident while crossing the road. It will reduce accident cases or suicide cases. It guides to blind people as their sensing power. It helps to make their life easier and faster. It helps to convert disable to able. It is provided in low cost which helps to buy anyone either he or she is rich or poor. Blind Smart Stick is a cheap and helpful device. We use Arduino Board, Sensors, GSM, Speaker, Motor, etc. to make as a smart device. It can sense right path to move and its operating system is easy to control. It indicates if any problem sense from it

This Smart stick will have an Ultrasonic sensor to sense distance from any obstacle, LDR to sense lighting conditions and a RF remote using which the blind man could remotely locate his stick. These are the things which are already present in market in blind smart stick, so my innovation to this project is adding a Jarvis virtual assistant, which gonna talk to blind person like a companion. The assistant gonna crack jokes, by using AI AND ML, it gonna analyze things happening around and narrate in interesting way to the person. . It can talk with the person as siri or alexa or google.

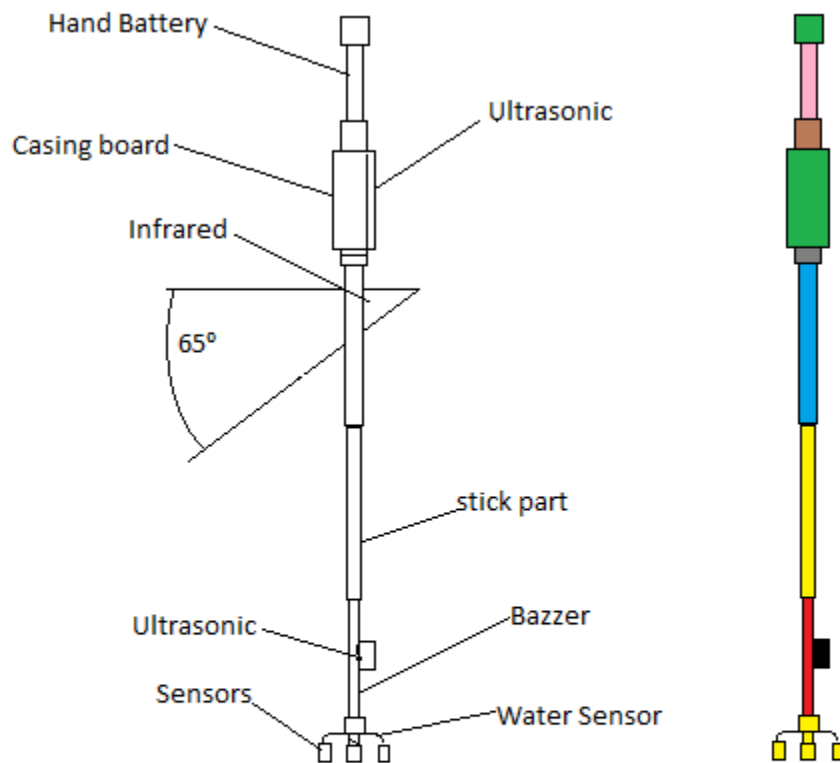

**Fig: Design of Smart Stick For Blind People**

## 5. Implementation (if any):

The proposed model provides improvement to the existing the device design. It tries to make the device more efficient, comfortable, convenient and user-friendly.

The component required for the implementation of the proposed design of the smart stick for blind people aer;

- Arduino Uno
- Infrared Sensor
- Water sensor
- GPS module

- GSM module
- Ultrasonic Sensors

a) Arduino Uno:-

Arduino uno is a open source microcontroller board based on microchip ATmega328P microcontroller and developed by Arduino.cc. The board has 14 digital (I/O) pins, 6 analog (I/O) pins, and is programmable with Arduino IDE, via a type B USB cable. It can be powered the USB cable or by 9-volts battery, through it accepts voltage between 7 and 20 volts.



b) Infrared Sensor:-

Infrared sensor recognize small obstacle but with less accuracy than laser sensors. However using laser sensor is costly which contradicts to our aim in obtaining affordable aiding devices. Infrared sensor includes a transmitter and a receiver. The IR transmitter is an IR LED (Light Emitting Diode) and the receiver is an IR photodiode which is sensitive to IR light of the same wavelength as that emitted by the IR LED. When IR light falls on the photodiode, its resistance and correspondingly its output voltage change in proportion to the magnitude of the IR light received. This is the principle of working of Infrared sensors. It can detect obstacles in a range within 50 cm at an angle of +/- 45 degrees accurately.



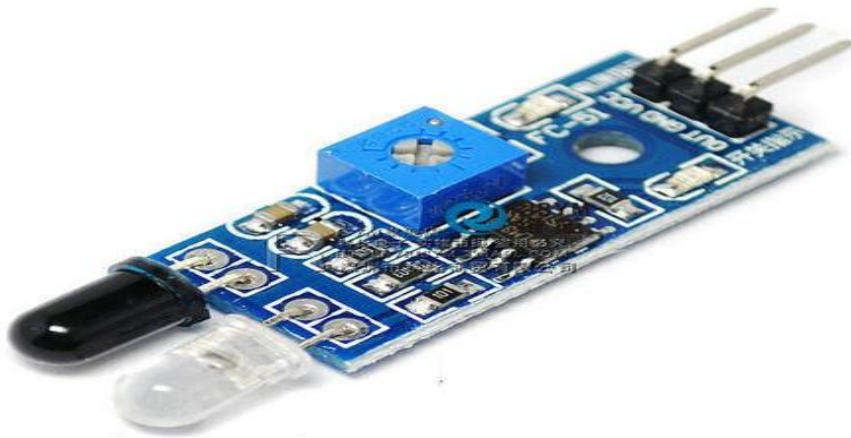

### c) Water Sensors:-

Water sensors available are used to detect water levels inside tanks and very expensive. Our objective is to detect water existence regardless its level. So we used a costless alternative. Three wire probes fit at the bottom of the stick to sense obstacle like water pits, puddles and water spread. Two wires are used to complete the circuit and another one wire is used to short circuit. Once wires touch water, the circuit is shorted, this interrupts the microcontroller, and beep sound is produced by the speaker to warn the blind person about the puddle.



#### d) GPS module:-

PS module: The GPS based device proposed, with user input interfacing get alert the blind person when he reaches the destination by voice. A GPS module consists of GPS receiver and an antenna. GPS antenna is a device that helps to boost the reception signal to a GPS unit. GPS (Global Positioning System) is a satellite system originally developed by the United States Department of Defense. It utilizes more than two dozen satellites orbiting the Earth to allow receivers to tell exactly where they are. Using this location, devices can detect not just latitude and longitude, but also altitude and even speed. A GPS unit is used in the smart stick to obtain the latitude and longitude of the location of the blind person. The data obtained are used to find the address of the blind person's location. While the person navigates with the stick, the latitude and longitude data are updated. Thus, these data are helpful to keep track of the blind person.

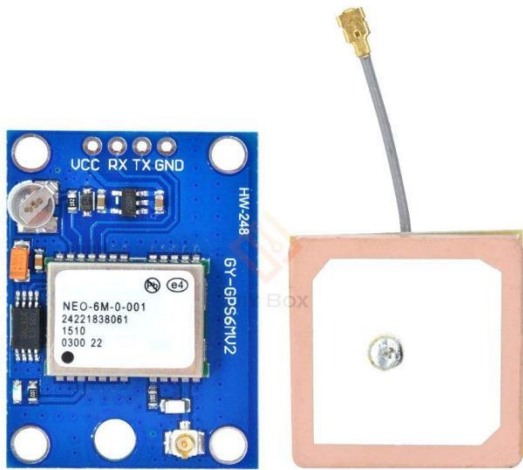

e) GSM module:-

GSM (Global System for Mobile communications) or GPRS (General Packet Radio Service) module is an embedded piece of hardware which can be integrated with an equipment to make use of the module's functionalities. GSM module requires a registered SIM card to be inserted into it in order to operate. It facilitates making and receiving voice calls, sending SMS messages wirelessly. GPRS is an extension to GSM data transmission capabilities. GPRS enables data transmission with higher speed than GSM. It provides inter-networking facility through internet.



*Humans are not disabled. A person can never be broken. Our built environment, our technologies, is broken and disabled. We the people need not accept our limitations, but can transfer disability through technological Innovation.*

This Smart stick will have an Ultrasonic sensor to sense distance from any obstacle, LDR to sense lighting conditions and a RF remote using which the blind man could remotely locate his stick.

These are the things which are already present in market in blind smart stick,so my innovation to this project is adding a Jarvis virtual assistant,which gonna talk to blind person like a companion.The assistant gonna crack jokes,by using AI AND ML it gonna analyze things happening around and narrate in a interesting way to the person.

### **Materials Required :**

1. Arduino Nano (Any version will work)
2. Ultrasonic Sensor HC-SR04
3. LDR
4. Buzzer and LED
5. 7805
6. 433MHz RF transmitter and receiver
7. Resistors
8. Push button
9. Perf board
10. Soldering Kit
11. 9V batteries

### **Circuit Diagram :**

This **Arduino Smart Blind Stick Project** requires two separate circuits. One is the main circuit which will be mounted on the blind man's stick. The other is a small remote **RF transmitter circuit** which will be used

to locate the main circuit. The main board's circuit diagram is shown below:

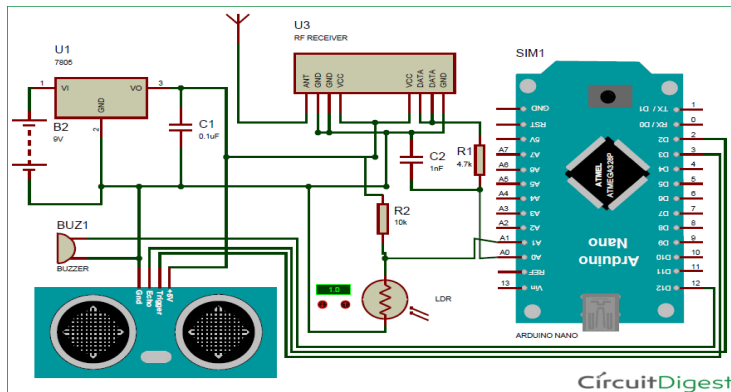

## Arduino Program for Smart Blind Stick :

Like all programs we start with *void setup()* to initialise Input Output pins. In our program the Buzzer and Trigger pin is an Output device and the Echo pin is an Input device. We also initialise the serial monitor for debugging.

```
void setup()
{
  Serial.begin(9600);
  pinMode(Buzz,OUTPUT);
  digitalWrite(Buzz,LOW);
  pinMode(trigger, OUTPUT);
  pinMode(echo, INPUT);
}
```

Inside the *main* loop we are reading all the sensors data. We begin with reading the sensor data of Ultrasonic sensor for distance, LDR for

light intensity and RF signal to check if the button is pressed. All these data is saved in a variable as shown below for future use.

```
calculate_distance(trigger,echo);  
  
Signal = analogRead(Remote);  
  
Intens = analogRead(Light);
```

We start with checking for the Remote signal. We use a variable called *similar\_count* to check how many times the same values are being repeated from the RF receiver. This repetition will occur only when the button is pressed. So we trigger the Remote pressed alarm if the count exceeds a value of 100.

```
//Check if Remote is pressed  
  
int temp = analogRead(Remote);  
  
similar_count=0;  
  
while (Signal==temp)  
{  
  
Signal = analogRead(Remote);  
  
similar_count++;  
  
}  
  
//If remote pressed  
  
if (similar_count<100)  
{  
  
Serial.print(similar_count); Serial.println("Remote Pressed");  
  
digitalWrite(Buzz,HIGH);delay(3000);digitalWrite(Buzz,LOW);  
  
}
```

Next we **check for the intensity of light around the blind man**. If the LDR gives a value of less than 200 it is assumed to be very dark and we give him the warning through buzzer with a specific tone of delay with 200ms. If the intensity is very bright that is more than 800 then also we give a warning with another tone. The alarm tone and intensity can be easily varied by changing the respective value in the below code.

```
//If very dark

if (Intens<200)

{

  Serial.print(Intens); Serial.println("Bright Light");

  digitalWrite(Buzz,HIGH);delay(200);digitalWrite(Buzz,LOW);delay(200);digitalWrite(Buzz,HIGH);delay(200);digitalWrite(Buzz,LOW);delay(200);

  delay(500);

}

//If very bright

if (Intens>800)

{

  Serial.print(Intens); Serial.println("Low Light");

  digitalWrite(Buzz,HIGH);delay(500);digitalWrite(Buzz,LOW);delay(500);digitalWrite(Buzz,HIGH);delay(500);digitalWrite(Buzz,LOW);delay(500);

}

}
```

Finally, we **start measuring the distance** from any obstacle. There will be no alarm if the measured distance is more than 50cm. But, **if it is less than 50cm the alarm will start by beeping the buzzer**. As the object gets closer to the buzzer the beeping

interval will also decrease. The closer the object is the faster the buzzer will beep. This can be done by creating a delay that is proportional to the distance measured. Since the *delay ()* in Arduino cannot accept variables we have to use a *for* loop which loop based on the measured distance as shown below.

```
if (dist<50)
{
  Serial.print(dist); Serial.println("Object Alert");

  digitalWrite(Buzz,HIGH);

  for (int i=dist; i>0; i--)

    delay(10);

  digitalWrite(Buzz,LOW);

  for (int i=dist; i>0; i--)

    delay(10);
}
```

The program can be easily adapted for your application by changing the value which we use to compare. You use the serial monitor to debug if a false alarm is trigger. If you have any problem you can use the comment section below to post your questions.

### **Arduino Blind Stick in Action :**

Finally it's time to test our project. Make sure the connections are done as per the circuit diagram and the program is successfully uploaded. Now, power both the circuits using a 9V battery and you should start to see results. Move the Ultra Sonic sensor closer to object and you will notice the Buzzer beeping and **this beeping frequency increases as the stick goes closer to object**. If the LDR is covered in dark or if there is



too much light the buzzer will beep. If everything is normal the buzzer will not beep.

When you press the button on the remote the buzzer will give a long beep. The **complete working of this Smart Blind Stick is shown in the Video** given at the end of this page. I also use a small stick to mount the complete assembly you can use a larger one or an actual blind stick and put it in action.

If your buzzer is always beeping it means the alarm is being false triggered. You can open the serial monitor to check for the parameters and check which is falling in critical and adjust that. As always you can post your problem in the comment section to get help. Hope you understood the project and enjoyed building something.

#### Code :

```
const int trigger = 3; //Trigger pin of 1st Sesnor
const int echo = 2; //Echo pin of 1st Sesnor
const int Buzz = 13; //Echo pin of 1st Sesnor
const int Remote = A0; //Echo pin of 1st Sesnor
const int Light = A1; //Echo pin of 1st Sesnor

long time_taken;
int dist;
int Signal;
int Intens;
int similar_count;

void setup() {
  Serial.begin(9600);
  pinMode(Buzz,OUTPUT);
  digitalWrite(Buzz,LOW);
  pinMode(trigger, OUTPUT);
  pinMode(echo, INPUT);
}

/*###Function to calculate distance###*/
void calculate_distance(int trigger, int echo)
{
  digitalWrite(trigger, LOW);
  delayMicroseconds(2);
  digitalWrite(trigger, HIGH);
```

```

delayMicroseconds(10);
digitalWrite(trigger, LOW);

time_taken = pulseIn(echo, HIGH);
dist= time_taken*0.034/2;
if (dist>300)
dist=300;
}

void loop() { //infinite loopy
calculate_distance(trigger,echo);
Signal = analogRead(Remote);
Intens = analogRead(Light);

//Check if Remote is pressed
int temp = analogRead(Remote);
similar_count=0;
while (Signal==temp)
{
Signal = analogRead(Remote);
similar_count++;
}

//If remote pressed
if (similar_count<100)
{
Serial.print(similar_count); Serial.println("Remote Pressed");
digitalWrite(Buzz,HIGH);delay(3000);digitalWrite(Buzz,LOW);
}

//If very dark
if (Intens<200)
{
Serial.print(Intens); Serial.println("Bright Light");
digitalWrite(Buzz,HIGH);delay(200);digitalWrite(Buzz,LOW);delay(200);digitalWrite(Buzz,HIGH);delay(200);

digitalWrite(Buzz,LOW);delay(200);
delay(500);
}

//If very bright
if (Intens>800)
{
Serial.print(Intens); Serial.println("Low Light");
digitalWrite(Buzz,HIGH);delay(500);digitalWrite(Buzz,LOW);delay(500);digitalWrite(Buzz,HIGH);delay(500);
}

```

```
digitalWrite(Buzz,LOW);delay(500);
}

if (dist<50)
{
  Serial.print(dist); Serial.println("Object Alert");

  digitalWrite(Buzz,HIGH);
  for (int i=dist; i>0; i--)
    delay(10);

  digitalWrite(Buzz,LOW);
  for (int i=dist; i>0; i--)
    delay(10);
}
```

## **6. Conclusions and Future Works:**

The smart stick for blind people is act as a basic platform which is useful for upcoming generation of much more aiding devices to help the blind people to become more safe and secure from accidents. It is more effective and affordable for rich or poor family. It give good result in detecting the materials or obstacles are available in a range of 3 meters, it also detects stairs, ditch fillup with water.

This stick is available or offered in a low cost, reliable, durable, low power consumption, reusable. The stick consist of hard wired with sensors and other components. It is light in weight which is easy to take anywhere. While setup of this device, blind people are the priority for this device.

## 7. References

1. H. R. CHOI, S. W. LEE, K. M. JUNG, J. C. KOO, S. I. LEE, H. G. CHOI, J.W. JEON, J.D. NAM, "TACTILE DISPLAY AS A BRAILLE DISPLAY FOR THE VISUALLY DISABLED". INTERNATIONAL CONFERENCE ON INTELLIGENT ROBOTS AND SYSTEMS, 2004, VOLUME:2.
2. PRADEEP MANOHAR AND APARAJIT PARTHASARATHY, "AN INNOVATIVE BRAILLE SYATEM KEYBOARD FOR THE VISUALLY IMPAIRED", 11TH INTERNATIONAL CONFERENCE ON COMPUTER MODELLING AND SIMULATION UKSIM 2009, 25-27 MARCH 2009.
3. ZHIHONG TIAN, JINSHENG YANG, JIANGUO ZHANG, "LOCATION-BASED SERVICES APPLIED TO AN ELECTRIC WHEELCHAIR BASED ON THE GPS AND GSM NETWORKS", INTERNATIONAL WORKSHOP ON INTELLINGENT SYSTEMS AND APPLICATIONS, ISA 2009, MAY 23-24 2009
4. <http://www.sih.gov.in>